

(No Model.)

3 Sheets—Sheet 1.

W. F. CLASS & A. J. WEATHERHEAD.

RECIPROCATING MOTOR.

No. 326,545.

Patented Sept. 22, 1885.

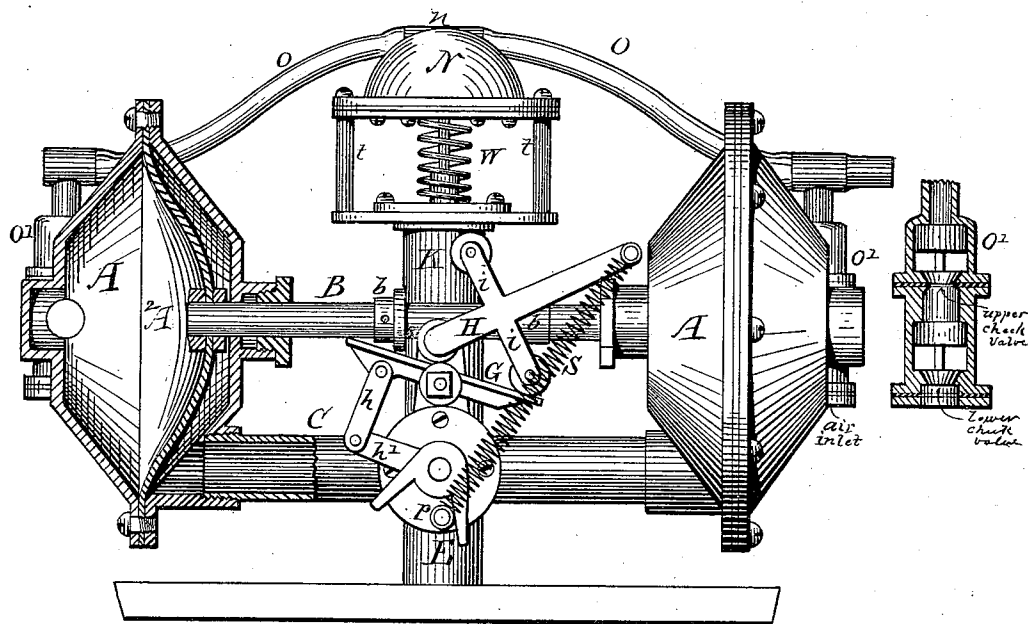

Fig. 1.

Witnesses,

B. R. Sibbitt.

A. B. Allen.

Inventors,

William F. Class.

Albert J. Weatherhead

per Geo. W. Sibbitt
attor

W. F. CLASS & A. J. WEATHERHEAD.

RECIPROCATING MOTOR.

No. 326,545.

Patented Sept. 22, 1885.

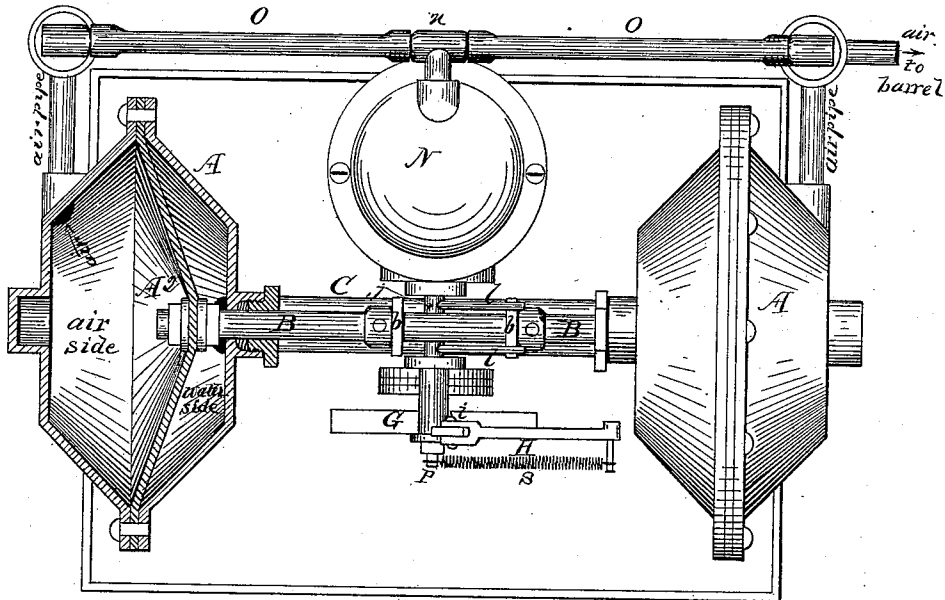

Fig. 2.

WITNESSES:

G. W. Tibbitts

A. B. Allen

INVENTOR

W. F. Class, A. J. Weatherhead
BY

Per Geo. W. Tibbitts
ATTORNEY

(No Model.)

3 Sheets—Sheet 3.

W. F. CLASS & A. J. WEATHERHEAD.

RECIPROCATING MOTOR.

No. 326,545.

Patented Sept. 22, 1885.

Fig. 4.

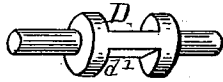
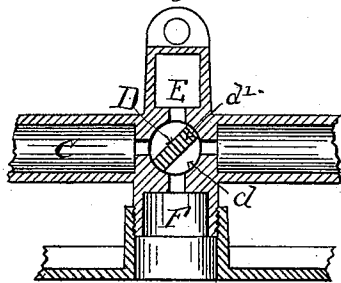

Fig. 5.

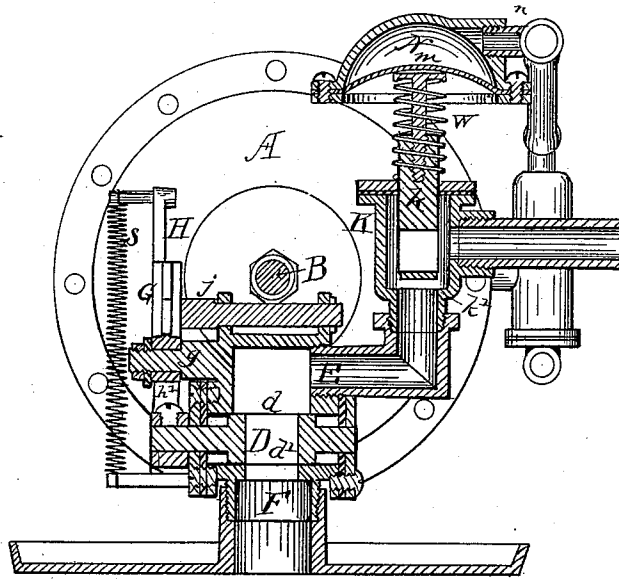
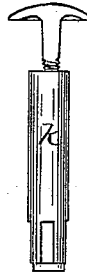

Fig. 3.

Witnesses,

F. R. Tibbitts.

Geo. B. Tibbitts

Inventors,

William F. Class

Albert J. Weatherhead

By Geo. W. Tibbitts atty

UNITED STATES PATENT OFFICE.

WILLIAM F. CLASS AND ALBERT J. WEATHERHEAD, OF CLEVELAND, OHIO,
ASSIGNORS OF ONE-THIRD TO GEORGE COLLINS, OF SAME PLACE.

RECIPROCATING MOTOR.

SPECIFICATION forming part of Letters Patent No. 326,545, dated September 22, 1885.

Application filed April 21, 1884. (No model.)

To all whom it may concern:

Be it known that we, WILLIAM F. CLASS and ALBERT J. WEATHERHEAD, of Cleveland, in the county of Cuyahoga and State of Ohio, have invented certain new and useful Improvements in Reciprocating Motors, of which the following is a specification.

This invention relates to certain improvements in reciprocating motors in which steam, water, air, or gas, under pressure, may be employed for actuating the pistons.

The object of the invention is to provide a motor for forcing air for various purposes, principally for supplying air-pressure to beer-barrels and air-carburetors.

This invention consists of the mechanism constructed, combined, and operating as hereinafter described and claimed.

In the accompanying drawings, Figure 1, Sheet 1, is a side elevation of our new motor. Fig. 2 is a top or plan view of the same. Fig. 3 is a cross-section through the aforesaid valve mechanisms. Fig. 4 is a cross-section of the lower valve. Fig. 5 is a detached view of the regulating-valve.

These improvements are designed to simplify the construction and arrangement of the several parts comprising such motors, whereby greater economy in manufacture and perfection of operation are obtained.

A, Figs. 1, 2, and 3, are conical shaped cylinders or chambers, composed of two cones having flanges by which the two are united and secured together. Interposed between said flanges, and secured therein, is a flexible disk diaphragm, A², dividing the chambers into two equal parts. These flexible diaphragms comprise the pistons. Said diaphragms are connected by one common piston-rod, B, which has a reciprocatory movement longitudinally between said cylinders, which stand on their edges and opposite to each other. The lower sides of said cylinders are connected by a pipe, C, in the middle part of which is located a valve mechanism for changing the course of the motive element from one cylinder to the other alternately. The chambers in said two cylinders toward each other are the power-sides, and the outer chambers are the air-forcing sides,

The valve consists of a plug, D, fitted in a

chamber, *d*, located midway between said cylinders A in the pipe C and at the crossing of the inlet and outlet pipes E F. The plug is cut away on two sides, leaving a central web, *d'*. The chamber *d* has four ports, which are controlled by said valve D, whereby the course of the motive element is alternately changed or directed from one cylinder to the other.

The valve is operated by a balance-lever, G, pivoted above it on a stud, *g*, and connected by link *h* to a crank-lever, *h'*, on the projecting stem of the plug D. Above the said balance-lever G is also placed a tilting-lever, H, having cross-arms *i i*, provided with friction-rolls *i'*, the tilting of which operates the balance-lever, changing the valve. The tilting-lever is attached to a shaft, *j*, set in bearings on the top of the valve-chamber and crosswise under the piston-rod B. On the piston-rod are two stops, *b b*, which carry with them, as the piston-rod moves, two levers, *l l*, fixed in the said shaft *j*, thereby throwing over the tilting-lever H, which, when it passes over the center, is thrown down quickly by the spring *s*, attached to its upper end, and a pin, *p*, projecting from the lower part of the valve-chamber. The arms *i i* of the tilting-lever strike upon the balance-lever, and thus the valve is quickly turned.

The regulating-valve consists of a chamber, K, attached to the inlet-pipe E, in which a vertical plug-valve, *k*, plays. (Seen in detached view, Fig. 5.) This plug has its seat at *k'*, and has a slot through its lower part in line with the inlet, the object of which is to relieve the plug of any side pressure from the incoming motive element, said element also surrounding the plug in its chamber. Above said chamber K is placed an air-pressure device for actuating said plug. It consists of a half-spherical chamber, N, supported by posts *t t*, and is provided with a flexible bottom, *m*, against which the top end of an adjustable head on the plug bears. Said head is also cushioned on a spring, W, surrounding the plug and resting on top of the chamber K. Air tubes or pipes O, which lead from the air-forcing sides of the cylinders A, pass by, and are connected with the chamber N by a T-joint, *n*. Said pipes O are connected to the

5 cylinders with a valve mechanism contained in chambers O', which consists of ordinary check-valves, one in the upper part of the chamber above the branch O², and the lower one below said branch. Thus the air is drawn into the cylinder through the lower check and forced through the upper check valve.

10 The purpose and object of this air-pressure connection with the valve is to serve to regulate the inflow of motive element in proportion to the resistance that said air-pressure has to meet, for, as the resistance is variable, the power to act against it must be regulated proportionately thereto. For instance, if the resistance in a barrel to which this pump is
15 connected is weak, the air from the pump will not press very hard on the plug, consequently the valve will be fully open, and the motive element have full entrance and force. Now, as the said resistance is overcome the pressure in the chamber K increases, and the plug is forced down, so that when the resistance and the power of the pump become equal the valve is entirely closed and the pump stops moving
20 until said resistance is again lowered.

This pump is designed to be attached to

beer-barrels to work automatically. Therefore when a glass or any quantity of beer is drawn from the barrel the pressure in said barrel lowers. Then the pump immediately begins to act, and works until the pressure in the barrel is regained, and so on until the contents of the barrel is entirely withdrawn. 30

Having described our invention, we claim—

1. The combination of pipe C, provided with chamber *d* and ports, the valve D, having web *d*², crank-lever *h*¹, link *h*, balance-lever G, tilting-lever H, the rock-shaft *j*, having levers *ll*, the piston-rod having stops *b b*, and a spring, S, substantially as set forth. 35

2. The regulating-valve mechanism consisting of the chamber K, provided with the slotted plug *k*, the half-spherical chamber N, having the flexible bottom bearing on the head of plug *k*, and cushioned by the spring W, in combination with inlet-pipe E and the air-pipe O, as and for the purpose specified. 40

WILLIAM F. CLASS.

ALBERT J. WEATHERHEAD.

Witnesses:

GEO. W. TIBBITTS,
M. G. NORTON.