

April 27, 1965

J. BALINT ETAL

3,180,528

HANGING CAP AND HOLDER FOR SQUEEZE TUBES

Filed Jan. 25, 1963

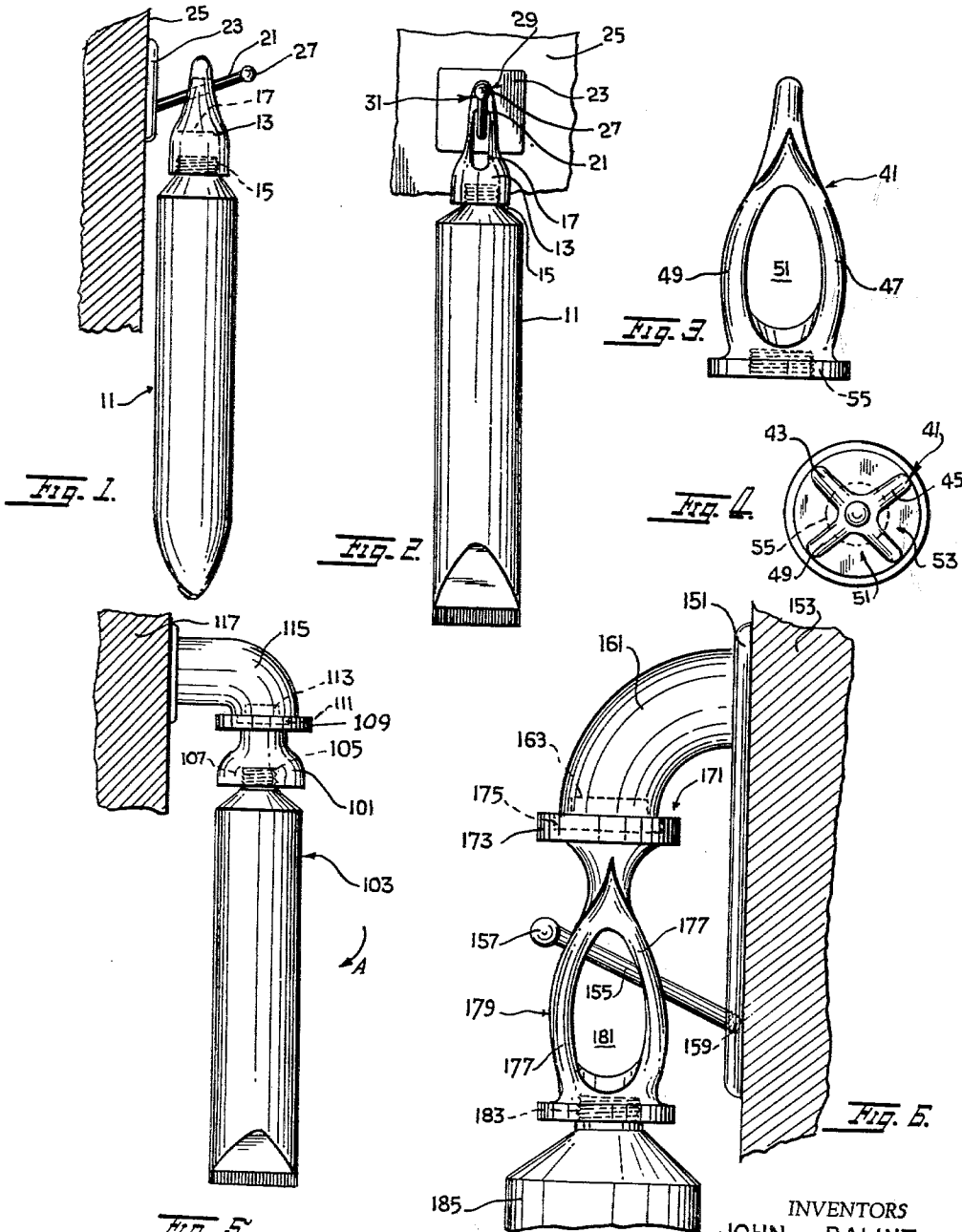

INVENTORS
JOHN BALINT
TIBOR HIRSCH

BY

Golden Polach
ATTORNEY

1

3,180,528

HANGING CAP AND HOLDER FOR
SQUEEZE TUBES

John Balint, 35-42 73rd St., Jackson Heights, N.Y., and
Tibor Hirsch, 5115 13th Ave., Brooklyn, N.Y.
Filed Jan. 25, 1963, Ser. No. 253,794
2 Claims. (Cl. 222-105)

This invention relates to container closures and more particularly to such closures constructed to facilitate storage of the container and the closure.

The present invention finds ready application to closures for collapsible tubes wherein such cover and tube are to be stored in a suspended position.

Many toiletries such as toothpaste and shave cream are sold in collapsible tubes. In addition to toiletries, many other things such as first aid supplies are also sold in collapsible tubes. Each such tube is provided with a cap or cover to close the dispensing opening formed in the tube. In general use the tubes are opened and closed many times before the material inside is completely used up. The caps are small and almost invariably get lost before the material in the tube is consumed. Furthermore, the tubes are difficult to store and take up valuable space in the already crowded medicine chest. Some attempts have been made to provide special caps for such tubes which special caps are fitted with suction cups or snap fasteners, however, the increased use of large economy size tubes which are heavy in weight makes the use of such caps inefficient. The weight of the material in the tubes has proved to be more than the suction cup or snap fastener can handle and the collapsible tube drops off the holder. Other special caps require only simple hooks but the hook allows the tube to tilt to one side thus marking the wall from which the tube is suspended and making acquisition and removal from the hook difficult if not impossible.

It is an object of the invention to provide a novel closure for a container.

Another object is to provide a container closure which facilitates storage of the container and closure when the two are secured together.

Still another object is to provide a novel container closure and suspending means therefor.

Still another object of this invention is to provide a novel cap and suspending means for a collapsible tube to suspend the tube by positive means.

The present invention contemplates a container closure having attaching means such as an aperture, or magnetizable plate, formed therewith. A suspending means is also provided in the form of a hook or magnet which coacts with the attaching means to suspended the closure, and the container when attached thereto, from a wall or shelf.

For further comprehension of the invention, and of the objects and advantages thereof, reference will be had to the following description and accompanying drawings, and to the appended claims in which the various novel features of the invention are more particularly set forth.

In the accompanying drawings forming a material part of this disclosure:

FIGURE 1 is a side view of a container and closure which embodies the present invention.

FIG. 2 is a front view of the container and closure of FIG. 1.

FIG. 3 is a view of a modified form of the closure of FIGS. 1 and 2.

FIG. 4 is a top view of the closure of FIG. 3.

FIG. 5 is a side view of another modified form of container and closure.

FIG. 6 is yet another modified form of container and closure.

2

Referring to the drawings for a more detailed description of the present invention, an embodiment thereof is shown incorporated in a collapsible tube type container such as the kind used to dispense toothpaste, and generally indicated by the numeral 11. It should be understood, however, that the hereinafter described application of the invention to a collapsible tube type container is for the purpose of illustration only inasmuch as the subject invention finds ready application to other types of closures for other types of containers.

A closure 13, provided for a container 11, has formed in the lower portion thereof screw threads 15 which are adapted to coact with threads formed on the collapsible tube container 11 around the dispensing opening (not shown) formed therein. An aperture 17 is also formed in closure 13. Aperture 17 is formed to coact with a hook-like member 21 carried by a plate 23 which is secured to wall 25 by suitable means such as adhesive or the like. A knob 27 having flattened sides 29 and 31 (FIG. 2) is provided at the extremity of hook-like member 21.

Container 11 may be threaded into or out of threads 15 while closure 13 is suspended from hook-like member 21. If preferred container 11 and closure 13, while still secured together, may be removed as a unit from hook-like member 21. To do so, container 11 is grasped and raised (FIG. 1) a distance sufficient to lift closure 13 off of hook-like member 21. Container 11 is then drawn towards the user so as to pass aperture 17 over knob 27.

To store either closure 13 alone or container 11 and closure 13, when assembled as a unit, aperture 17 is passed over knob 27 and the unit released allowing closure 13 to seat on hook-like member 21. Knob 27 prevents accidental dislodgment of closure 13 and thereby container 11 from hook-like member 21.

The embodiment of FIGS. 3 and 4 shows a closure 41 formed with four ribs 43, 45, 47 and 49 (FIG. 4) equally spaced thereabout. Ribs 43, and 45, and ribs 49 and 47 coact to form a first passageway 51 (FIGS. 3 and 4). Ribs 43 and 49, and ribs 45 and 47 coact to form a second passageway 53 (FIG. 3). Closure 41 is fitted with a threaded opening 55 adapted for coaction with the threaded portion of the container.

In use, closure 41 is threaded onto a container such as container 11. To suspended same from hook-like member 21, knob 27 is passed through either passageway 51 or passageway 53 and the container released allowing closure 41 to seat on hook-like member 21.

In the embodiment shown in FIG. 5 the apertured closure and hook-like member have been dispensed with and a closure 101 is provided for a container 103. Threads 105 formed in closure 101 coact with threads 107 formed around the dispensing opening provided in closure 101. A flat platform 109, formed along the top of closure 101, has imbedded therein a plate 111 of magnetizable material. A magnet 113, imbedded in a support 115 secured to wall 117 by suitable means, coacts with plate 111 to suspended container 103 as shown in FIG. 5.

Magnet 113 establishes strong magnetic attraction for plate 111 sufficient to counteract the weight of the heaviest container 103. To remove container 103 from support 115 one need only move same in the direction of arrow A, until the closure 101 and magnet 113 separate. It is much easier to separate the two by sliding closure 101 along the surface of support 115 than to pull the two apart.

In the embodiment of FIG. 6, a plate 151 is secured to wall 153 by suitable means. A hook-like member 155, having formed thereon a knob 157 (similar to knob 27 of FIG. 1), is threaded into plate 151 as at 159. A sup-

port 161 having a magnet 163 imbedded therein is also disposed on plate 151.

In use, plate 151 may be used with either a closure such as the one shown in FIG. 5 (to do so hook-like member 155 should be removed from plate 151) or with a closure such as the ones shown in FIGS. 1 and 3. A special closure may also be used with plate 151. Special closure 171 is provided with both a platform 173 having a magnetizable plate 175 imbedded therein and ribs 177 forming passageways 179 and 181. A threaded opening 183 formed in closure 171 is adapted to fit over the opening provided in container 185. When properly positioned closure 171 is secured in position by both the coaction between magnet 163 and magnetizable plate 175 and the coaction between ribs 177 and hook-like member 155.

While we have illustrated and described the preferred embodiments of our invention, it is to be understood that we do not limit ourselves to the precise constructions herein disclosed and that various changes and modifications may be made within the scope of the invention as defined in the appended claims.

Having thus described our invention, what we claim as new, and desire to secure by United States Letters Patent is:

1. For use with a collapsible tube having a dispensing opening therein, in combination a closure for sealing said opening and suspending said tube, comprising, a cap adapted to be secured to said tube to seal the opening therein, said closure having apertures passing therethrough, suspension means formed with said cap, plate means having formed thereon support means coacting with said suspension means to support said tube along a line passing through the center of gravity thereof and in a positive manner, said plate means being adapted to be affixed to a wall to mount the closure and tube thereon, said support

means including a device for passage through any of said apertures, a magnetizable plate imbedded in the top of said closure, said support means further including a magnet adapted to be placed in juxtaposition to said magnetizable plate.

2. For use with a collapsible tube having a dispensing opening therein, in combination a closure for sealing said opening and suspending said tube, comprising, a cap adapted to be secured to said tube to seal the opening therein, suspension means formed with said cap, plate means having formed thereon support means coacting with said suspension means to support said tube along a line passing through the center of gravity thereof and in a positive manner, said plate means being adapted to be affixed to a wall to mount the closure and tube thereon, said support means including plural apertures passing through said closure, one of said apertures being formed at right angles to and passing through said other aperture, said support means including a hook-like element adapted for passage through any of said apertures, said support means further including a magnetizable plate imbedded in the top of said closure, said support means further including a magnet adapted to be placed in juxtaposition to said magnetizable plate.

References Cited by the Examiner

UNITED STATES PATENTS

266,420	10/82	Blair et al.	222—105
975,348	11/10	Gerdzen	248—108 X
1,641,880	9/27	Cohen.	
2,009,552	7/35	Jaen	222—180 X
2,907,085	10/59	Bosland.	

LOUIS J. DEMBO, *Primary Examiner.*

RAPHAEL M. LUPO, *Examiner.*