

632041

SPRUSON & FERGUSON

AUSTRALIA

PATENTS ACT 1990

PATENT REQUEST: STANDARD PATENT

I/We, the Applicant(s)/Nominated Person(s) specified below, request I/We be granted a patent for the invention disclosed in the accompanying standard complete specification.

[70,71] Applicant(s)/Nominated Person(s):

NEC Corporation, incorporated in Japan, of 7-1, Shiba 5-chome,
Minato-ku, Tokyo, JAPAN

[54] Invention Title:

Mobile Radio Communication System

[72] Inventor(s):

Susumu Kojima

[74] Address for service in Australia:

Spruson & Ferguson, Patent Attorneys
Level 33 St Martins Tower
31 Market Street
Sydney New South Wales Australia (Code SF)

	Details of Basic Application(s):	
[31] Appl'n No(s):	[33] Country:	[32] Application Date:
3-122581	JP	24 April 1991

DATED this TWENTY THIRD day of APRIL 1992

NEC Corporation

By:

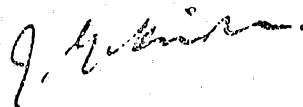

Registered Patent Attorney

IRN: 208799

INSTR CODE: 56179

5845/6

SPRUSON & FERGUSON

Australia

Patents Act 1990

NOTICE OF ENTITLEMENT

I, Fraser Patison Old, of Spruson & Ferguson, St Martins Tower, 31 Market Street, Sydney 2000, New South Wales, Australia, being the patent attorney for the Applicant/Nominated Person in respect of Application No 15056/92 state the following:-

The Applicant/Nominated Person has entitlement from the actual inventor(s) as follows:-

The Applicant/Nominated Person, by virtue of a Contract of Employment between the actual inventor(s) as employee(s) and the Applicant/Nominated Person as employer, is a person which would be entitled to have the patent assigned to it if a patent were granted on an application made by the actual inventor(s).

The Applicant/Nominated Person is the applicant of the basic application(s) listed on the Patent Request.

The basic application(s) listed on the Patent Request is/are the application(s) first made in a Convention Country in respect of the invention.

DATED this

24th

day of

June

1992

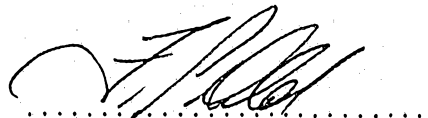

F P Old

IRN: 208799

INSTR CODE: 56179

JED/2387T

652041

S & F Ref: 208799

AUSTRALIA
PATENTS ACT 1990

COMPLETE SPECIFICATION

FOR A STANDARD PATENT

ORIGINAL

Name and Address
of Applicant:

NEC Corporation
7-1, Shiba 5-chome
Minato-ku
Tokyo
JAPAN

Actual Inventor(s): Susumu Kojima

Address for Service: Spruson & Ferguson, Patent Attorneys
Level 33 St Martins Tower, 31 Market Street
Sydney, New South Wales, 2000, Australia

Invention Title: Mobile Radio Communication System

The following statement is a full description of this invention, including the best method of performing it known to me/us:-

MOBILE RADIO COMMUNICATION SYSTEM

BACKGROUND OF THE INVENTION

The present invention relates to a cordless telephone system or similar mobile radio communication system which limits the service available for a radio terminal in an exclusive zone allocated to the terminal and removes the limitation in a common zone while opening all the zones to a particular radio terminal.

The installation of a cordless telephone system in offices is spreading. A service area covering an office is usually wider than one covering a home, it is divided into a plurality of radio zones. In this kind of system, a particular zone identification (ID) signal is assigned to each radio zone together with a common system ID code. The zones where individual radio terminals are positioned are registered to control the correspondence between the zone ID codes and terminal ID codes. Each terminal, therefore, can be serviced with no regard to the location so long as it lies in the service area. However, assuming a single building accommodating a plurality of tenants, e. g. , companies, charges and user rights have to be taken into account. Then, it is necessary to limit the service area where a

radio terminal can be serviced on a company basis. Should all the radio terminals belonging to the system be serviced in any place inside the building, a radio base station assigned to a certain company might be used illicitly by radio terminals
5 belonging to the other companies. On the other hand, when the service area available for a company is limited on a floor basis, radio terminals owned by a company cannot be serviced in a common space inside the building, e. g., restaurant or lobby. Further, such a configuration limits even the service area
10 available for a radio terminal used by, for example, a guard inside the building despite that the role of such a particular terminal should be shared by all the other terminals.

SUMMARY OF THE INVENTION

15 It is therefore an object of the present invention to provide a cordless telephone system or similar mobile radio communication system which limits the service area on a company basis and, in addition, opens a particular zone to all the radio terminals while allowing a particular radio terminal to
20 be serviced any zone.

In accordance with the present invention, ^{there is disclosed} in a mobile radio communication system having a service area divided into a plurality of radio zones and comprising a radio base station assigned to each of the radio zones and connected to a line
25 controller connected to subscriber lines which extend from a

public switched telephone network, and a plurality of radio terminals connectable to the radio base station over a radio channel, the radio base station and radio terminals each comprise a tenant identification (ID) data storage for storing tenant ID data. The tenant ID data relates to ones of the radio zones in which a radio terminal permissibly can be used. The radio terminals each comprise tenant ID data transmitting section for transmitting, before the radio channel is set up, the tenant ID data read out of the tenant ID data storing section to the radio base station. The radio base station comprises a radio channel connecting section for comparing the received tenant ID data with the tenant ID data assigned to the radio base station and, if the two tenant ID data are identical, setting up the radio channel.

BRIEF DESCRIPTION OF THE DRAWINGS

The above and other objects, features and advantages of the present invention will become more apparent from the following detailed description taken with the accompanying drawings in which:

15 FIG. 1 is a block diagram schematically showing a mobile radio communication system embodying the present invention;

FIG.2 is a block diagram schematically showing the arrangement of each radio zone included in the embodiment;

FIG. 3 is a block diagram schematically showing a specific construction of each
20 radio base station of the

embodiment;

FIG. 4 is a block diagram schematically showing a specific construction of each radio terminal of the embodiment;

5 FIG. 5 is a diagram representative of a connection sequence in which a call is originated on any of the radio terminals;

FIG. 6 shows a specific format of tenant ID data particular to the embodiment;

10 FIG. 7 lists tenant ID data each being assigned to respective one of radio terminals and radio base stations; and

FIG. 8 is a flowchart demonstrating a specific procedure for comparing the tenant ID data.

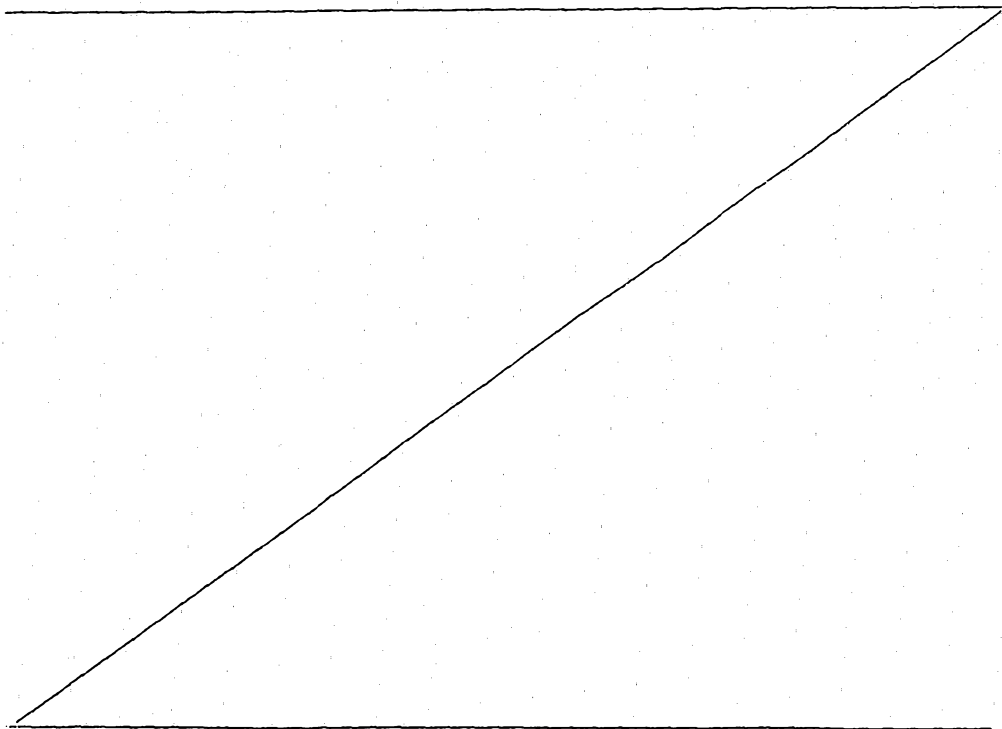

DESCRIPTION OF THE PREFERRED EMBODIMENT

Referring to FIG. 1 of the drawings, a mobile radio communication system embodying the present invention is shown and implemented as a cordless telephone system by way of example. As shown, the cordless telephone system has a service area divided into a plurality of, e. g., five radio zones 30, 31, 32, 33 and 34. Assume that the radio zones 30, 31, 32, 33 and 34 are accommodated in a five-story building and respectively assigned to the first and second floors occupied by a company A, the third floor occupied by a company B, the fourth floor occupied by a company C, and the fifth floor on which a restaurant or similar common facility to be shared by the companies A-C is. Each of the floors has an area which can be covered by a single radio base station. Specifically, radio base stations 20, 21, 22, 23 and 24 are respectively situated on the first to fifth floors to define the radio zones 30-34. A line controller 10 is connected to a public switched telephone network by subscriber lines 11 and connected to the radio base stations 20-24 by tie lines 12. Mobile units or radio terminals A1-A7, radio terminals B1-B3, and radio terminals C1-C3 belong to the companies A, B and C, respectively. A radio terminal X1 is allocated to a guard stationed at the building. In the specific condition shown in the figure, the terminal A7 belonging to the company A is positioned at the common space or restaurant on the fourth floor, the terminal X1 is located at a guard's room on

the second floor, and the other terminals are positioned on the floors belonging to the respective companies. Since the radio zones 30-34 have an identical arrangement, let the following description concentrate on the radio zone 30 by way of example.

5 As shown in FIG. 2, the radio zone 30 has a radio base station 2 connected to the line controller 10 by the tie line, and a plurality of mobile units or radio terminals 3 connectable to the base station over a radio channel 7. The base station 2 and terminals 3 each includes tenant identification (ID) data storing means 4 storing data which identifies the associated tenant.
10 Each terminal 3 has tenant ID sending means 6 for sending, before the radio channel 7 is set up, the tenant ID data read out of the storing means 4 to the base station 2. The base station 2 has channel connecting means 5 for comparing the tenant ID data sent from any one of the terminals 3 over the radio channel with
15 the tenant ID data stored in the storing means 4 thereof and, if the former is coincident with the latter, setting up the radio channel 7. The base station 2 further includes means for executing control when the tenant ID data sent from the terminal
20 3 has a first predetermined value by determining that the two ID data are identical, and means for executing control when the tenant ID data stored in its own tenant ID data storing means 4 has a second predetermined value by determining that the two ID data compare equal.

25 Referring to FIG. 3, a specific construction of the base

station 2 will be described. As shown, the base station 2 has an antenna 201, a transmitter 202, a receiver 203, an antenna duplexer 204, a tenant ID data storage 205, a controller 206, a control signal interchanging section 207, a line connecting section 208, and a signal switching section 209. The controller 206 controls the constituents of the base station 2 over a control bus 210. The base station 2 is connected to the line controller 10 via the line connecting section 208 and tie line 12. While a conversation is under way, a voice signal from the line controller 10 is delivered to the transmitter 202 via the line connecting section 208 and signal switching section 202. In response, the transmitter 202 modulates a carrier by the voice signal while sending the resulting signal to the terminal 3 of interest via the duplexer 204, and antenna 201. A voice signal received from the terminal 3 via the antenna 201 and duplexer 204 is demodulated by the receiver 203 and then fed to the line controller 10 via the line connecting section 208. On the other hand, in a standby state, the line controller 206 constantly monitors the control signal interchanging section 207 and line connecting section 208 to see if a connection request signal has been received from the terminal 3 and if a call has been terminated from the line controller 10. On receiving a connection request signal from the terminal 3, the base station 2 reads the ID data assigned to the tenant out of the tenant ID data storage 205 and compares it with the tenant ID data included in

the signal sent from the terminal 3. If the two ID data are identical, the base station 2 sends a channel designation signal to the terminal 3 by controlling the control signal interchanging section 207 and signal switching section 209. If otherwise, the
5 base station 2 rejects the connection request signal.

FIG. 4 shows a specific construction of the mobile unit or radio terminal 3. As shown, the terminal 3 has an antenna 301, a transmitter 302, a receiver 303, an antenna duplexer 304, a tenant ID data storage 305, a controller 306, a control
10 signal interchanging section 307, a signal switching section 308, a mouthpiece 309, an earpiece 310, and keys 311 consisting of numeral keys and function keys. The controller 306 controls the various parts of the terminal 3 over a control bus 312. While a conversation is held on the terminal 3, a voice signal is received
15 from the base station 2 via the antenna 301 and duplexer 304, demodulated by the receiver 303, and fed to the earpiece 310. A voice signal from the mouthpiece 309 is applied to the transmitter 302 via the signal switching section 308. In response, the transmitter 302 modulates a carrier by the voice
20 signal while sending the resulting signal to the base station 2 via the duplexer 304 and antenna 301. In a standby state, the controller 306 constantly checks the control signal interchanging section 307 and keys 311 to see if a call signal has been received from the base station 2 and if the keys 311 have been operated
25 for originating a call. On detecting a call originating operation

on the keys 311, the controller 306 reads the tenant ID data assigned to the tenant out of the tenant ID storage 305, formats it in a connection request signal, and sends the resulting signal to the base station 2 by controlling the control signal
5 interchanging section 307 and signal switching section 308.

FIG. 5 shows a connection sequence to be executed when a call is originated on the radio terminal 3. Connection control and conversation are implemented by a radio control channel and a radio voice channel, respectively. The connection request
10 signal which the terminal 3 sends first and the channel designation signal which the base station 2 returns on receiving the connection request signal are transmitted and received in bursts over the control channel. In the other radio sections, signals are interchanged over the voice channel specified by the
15 channel designation signal.

FIG. 6 shows a specific format of the tenant ID data to be sent from the terminal 3 to the base station 2. As shown, the format has a bit synchronization (SYNC) field at the leading end thereof and a frame SYNC field, signal discrimination field
20 and a data field which sequentially follow the bit SYNC field. The data field includes system ID data, zone ID data, terminal ID data, and tenant ID data. All the ID data except for the zone ID data are particular fixed data stored in each of the terminals 3, while the zone ID data identifies a zone where the terminal 3 has
25 the position thereof registered and, therefore, it is updated

every time the terminal 3 moves from one zone to another. The connection request signal shown in FIG. 5 is sent from the terminal 3 in the format shown in FIG. 6. The base station 2 compares the tenant ID data included in the connection request signal with the tenant ID data stored therein.

FIG. 7 lists specific tenant ID codes each being assigned to respective one of the radio terminals 3 and radio base stations 2. FIG. 8 demonstrates a specific procedure for comparing the tenant ID data. In the embodiment, the base station 2 to which the tenant ID code "0" is assigned designates a channel in response to a connection requests from every terminal 3, while every base station 2 designates a channel in response to a connection request from a particular terminal 3 to which the tenant ID code "0" is assigned. Stated another way, every base station 2 handles the tenant ID code "0" in the same way with no regard to the result of comparison. For example, all the terminals A1-A6, B1-B3 and C1-C3 belonging to the respective companies can be serviced at the common floor where the base station 24, FIG. 1, is situated, and the terminal X2 located at the guard's room can be serviced on all the floors of the building.

In summary, it will be seen that the present invention provides a mobile radio communication system which, assuming a single building accommodating a plurality of companies, limits the area where radio terminals can be serviced on a company

basis, allows all the terminals belonging to respective companies to be serviced at a restaurant, lobby or similar common space, and allows an exclusive terminal for a guard, for example, to be serviced in all the arears inside the building.

- 5 Various modifications will become possible for those skilled in the art after receiving the teachings of the present disclosure without departing from the scope thereof.

The claims defining the invention are as follows:

1. A mobile radio communication system having a service area divided into a plurality of radio zones and comprising a radio base station assigned to each of said plurality of radio zones and connected to a line controller connected to subscriber lines
5 which extend from a public switched telephone network, and a plurality of radio terminals connectable to said radio base station over a radio channel, said radio base station and said radio terminals each comprising tenant identification (ID) data storing means for storing tenant ID data, the tenant ID data relating to ones of the radio zones in which a radio terminal permissibly can be used;

10 said radio terminals each comprising tenant ID data transmitting means for transmitting, before the radio channel is set up, the tenant ID data read out of said tenant ID data storing means to said radio base station;

said radio base station comprising radio channel connecting means for comparing the received tenant ID data with the tenant ID data assigned to said radio base station and,
15 if the two tenant ID data are identical, setting up the radio channel.

2. A system as claimed in claim 1, wherein said radio base station further comprises:

means for executing, if the tenant ID data received from any one of said radio terminals has a first predetermined value, control by determining that said tenant ID data
20 received is identical with the ID data stored in said base station; and

means for executing, if the tenant ID data stored in said

radio base station has a second predetermined value, control by
determining said said tenant ID data is identical with the received
10 tenant ID data.

DATED this TWENTY-SECOND day of APRIL 1992
NEC Corporation

Patent Attorneys for the Applicant
SPRUSON & FERGUSON

Mobile Radio Communication System

Abstract of the Disclosure

A cordless telephone system or similar mobile radio communication system which limits the service available for a mobile unit (An, Bn, Cn) or radio terminal in an exclusive zone assigned to the terminal and removes the limitation in a common zone while opening all the zones to a particular radio terminal (20 - 24). Assuming a single building accommodating a plurality of companies (30 - 34), the area where radio terminals (20 - 24) can be serviced is limited on a company basis. All the terminals belonging to the respective companies are serviced at a restaurant, lobby or similar common space (34) inside the building. An exclusive terminal for a guard, for example, is serviced in all the areas inside the building.

(Figure 1)

Fig. 1

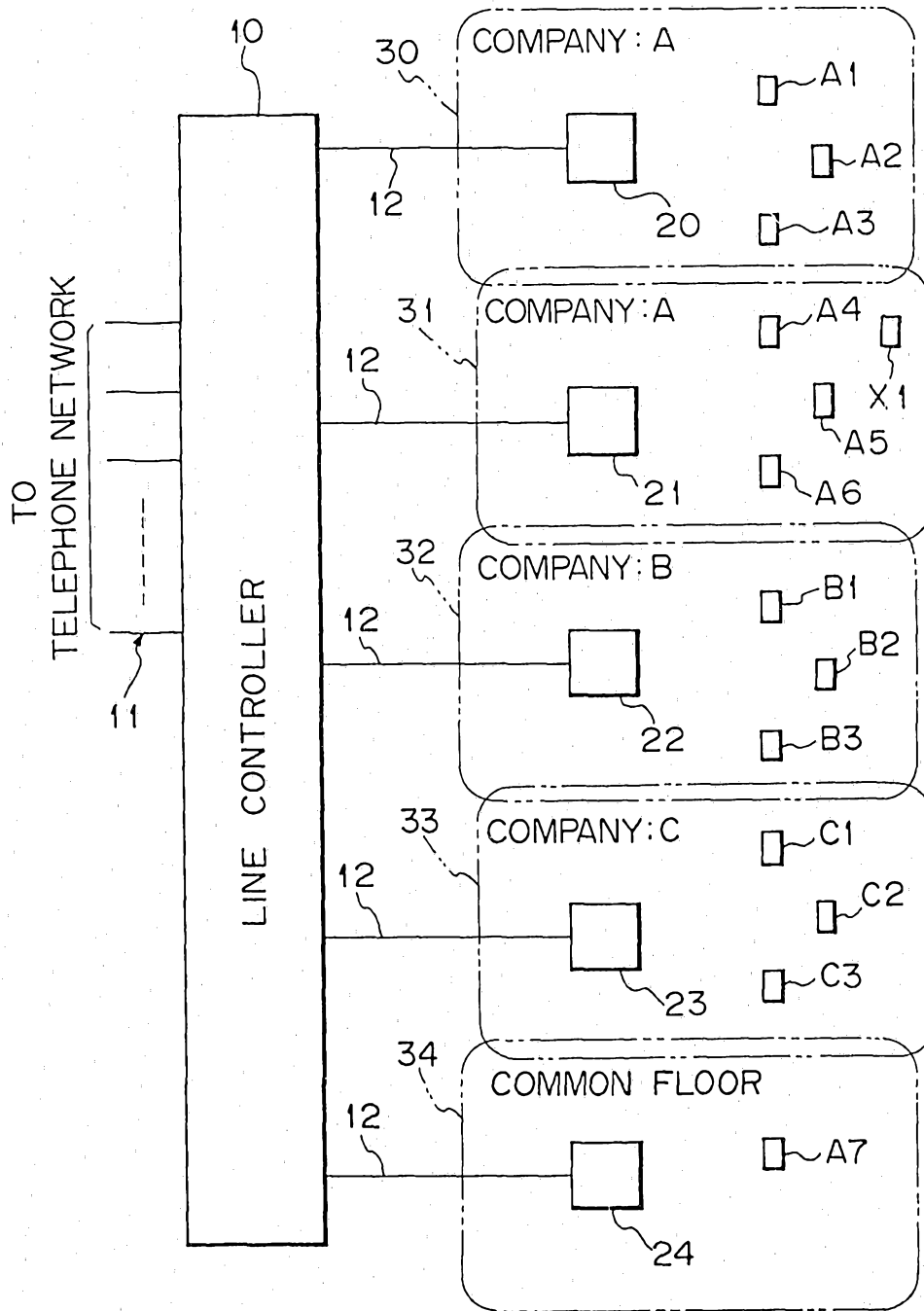

Fig. 2

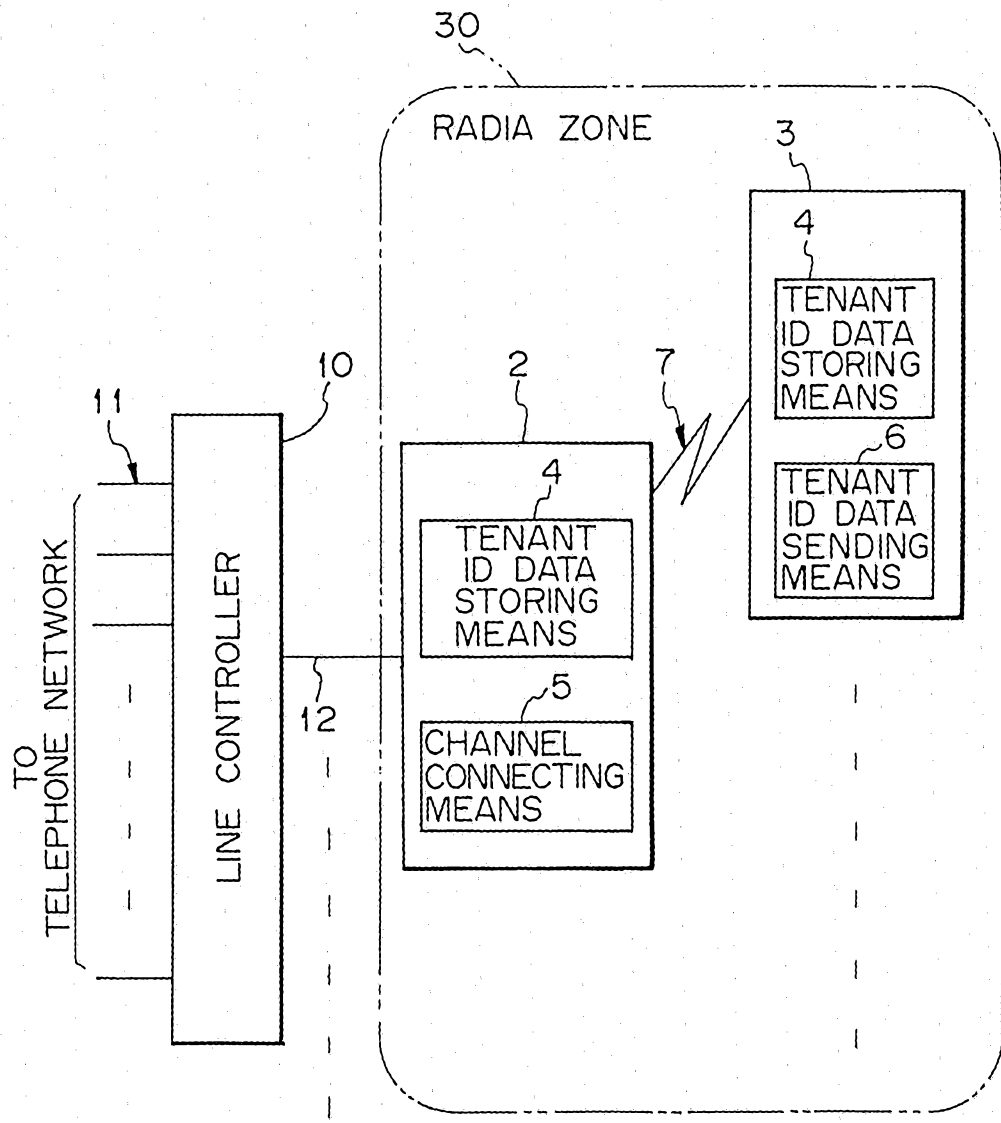

Fig. 3

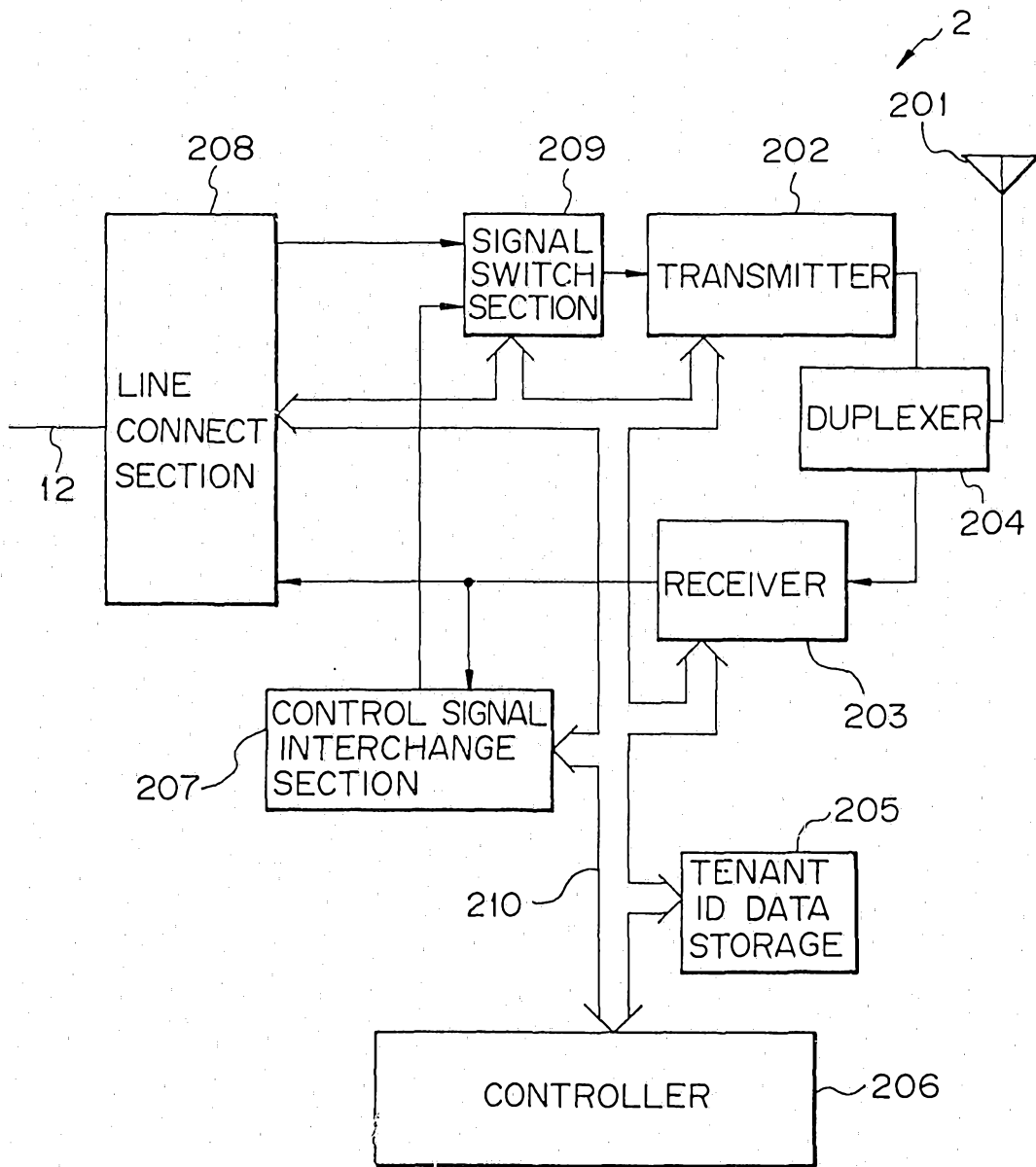

Fig. 4

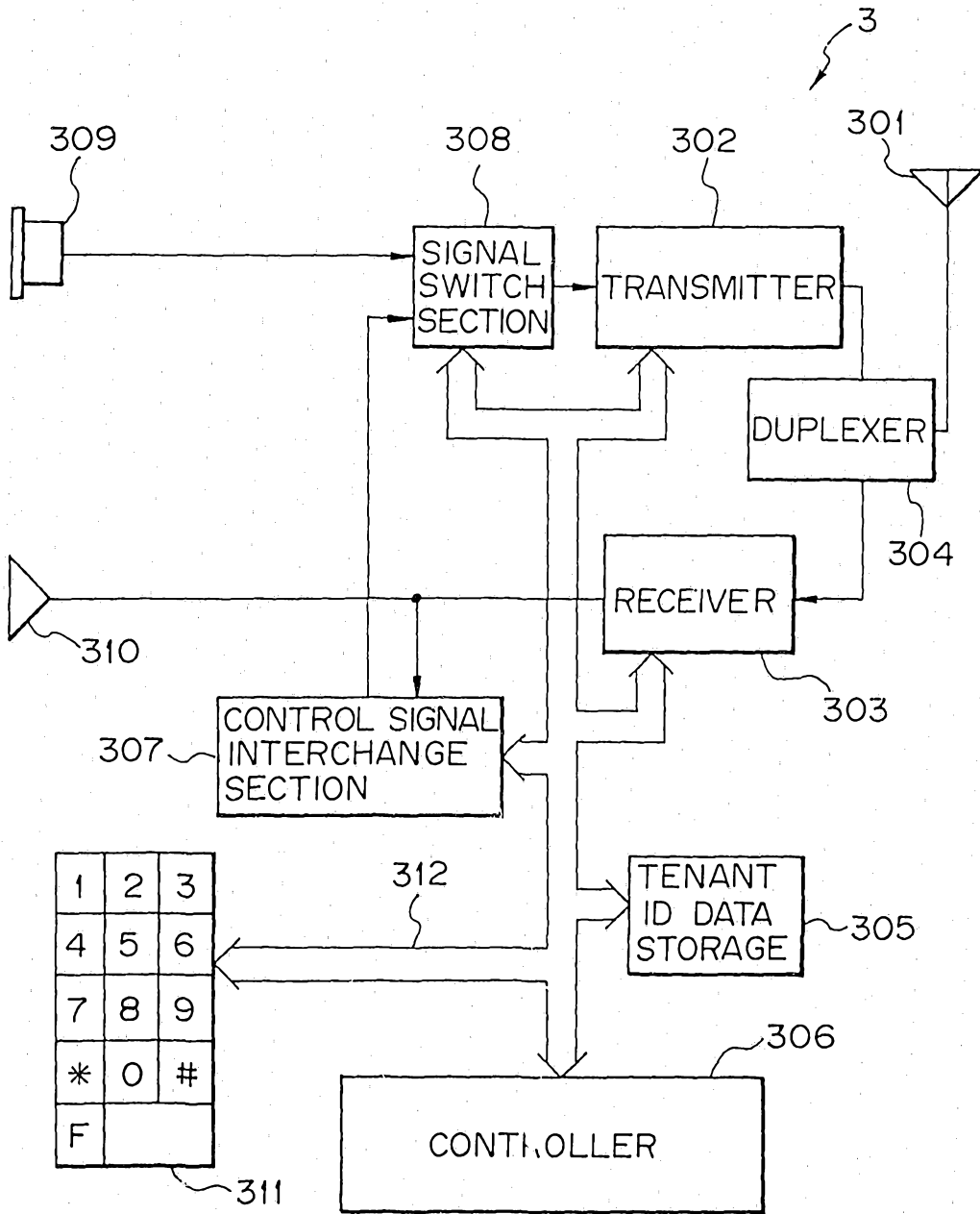
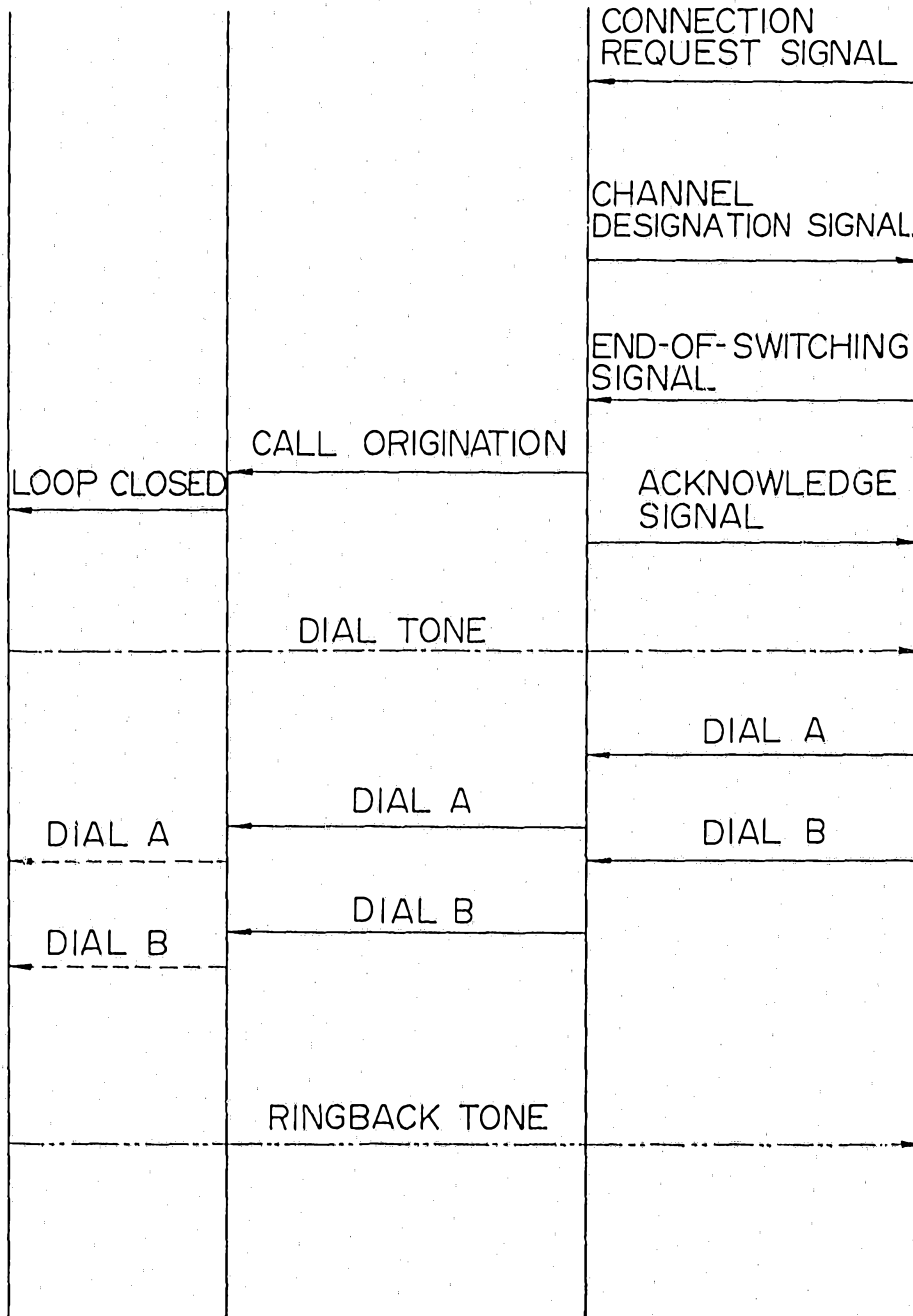

Fig. 5

TELEPHONE NETWORK LINE CONTROLLER 10 BASE STATION 2 TERMINAL 3



6/7

Fig. 6

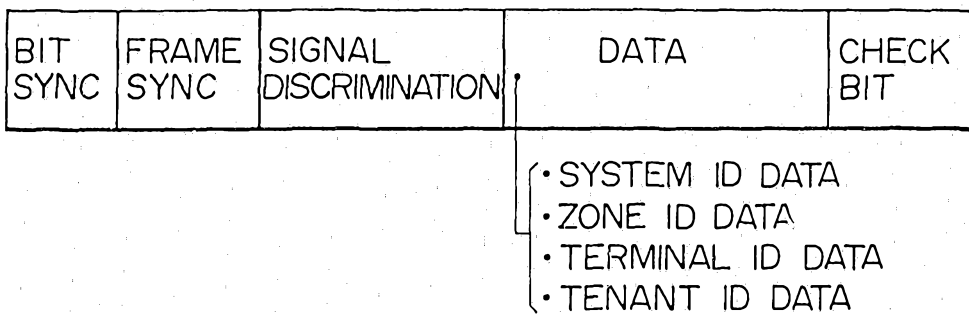

Fig. 7

TENANT ID DATA	TERMINAL 3	BASE STATION 2
0	X1	24
1	A1, A2, A3, A4, A5, A6, A7	20, 21
2	B1, B2, B3	22
3	C1, C2, C3	23

Fig. 8

