

(12) **United States Patent**
Arand

(10) **Patent No.:** **US 11,904,228 B2**
(45) **Date of Patent:** **Feb. 20, 2024**

(54) **SYSTEMS AND METHODS FOR PLAYING A GOLF GAME WITHIN LIMITED CONFINES**

(71) Applicant: **Joseph F. Arand**, Chicago, IL (US)
(72) Inventor: **Joseph F. Arand**, Chicago, IL (US)
(*) Notice: Subject to any disclaimer, the term of this patent is extended or adjusted under 35 U.S.C. 154(b) by 146 days.

(21) Appl. No.: **17/492,619**
(22) Filed: **Oct. 3, 2021**

(65) **Prior Publication Data**
US 2022/0105416 A1 Apr. 7, 2022

Related U.S. Application Data
(60) Provisional application No. 63/138,416, filed on Jan. 16, 2021, provisional application No. 63/087,687, filed on Oct. 5, 2020.

(51) **Int. Cl.**
A63B 71/04 (2006.01)
A63B 71/06 (2006.01)
A63B 43/00 (2006.01)
A63B 69/36 (2006.01)

(52) **U.S. Cl.**
CPC **A63B 71/0622** (2013.01); **A63B 43/004** (2013.01); **A63B 69/3661** (2013.01); **A63B 71/04** (2013.01); **A63B 2071/0638** (2013.01); **A63B 2220/35** (2013.01); **A63B 2225/50** (2013.01)

(58) **Field of Classification Search**
CPC .. A63B 69/3661; A63B 71/0622; A63B 71/04
See application file for complete search history.

(56) **References Cited**

U.S. PATENT DOCUMENTS

5,390,927	A *	2/1995	Angelos	A63B 69/36
				434/252
5,855,522	A *	1/1999	Bevan	A63B 67/02
				473/160
9,993,712	B2 *	6/2018	Coffman	A63B 67/02
10,486,047	B2 *	11/2019	Coffman	A63B 69/3661
2011/0192096	A1 *	8/2011	Koberinski	E04B 5/43
				52/126.6
2014/0004969	A1 *	1/2014	Jang	G06T 7/248
				473/409
2015/0011279	A1 *	1/2015	Koo	A63F 13/573
				463/3
2015/0072746	A1 *	3/2015	Jang	A63B 69/3676
				463/3
2015/0080142	A1 *	3/2015	Kline	A63B 37/0075
				473/221
2015/0094168	A1 *	4/2015	Unger, Sr.	A63B 57/357
				473/353
2018/0221747	A1 *	8/2018	Coffman	A63B 69/3661
2019/0022509	A1 *	1/2019	Lee	A63B 71/0622
2019/0099655	A1 *	4/2019	Park	A63B 69/3623
2019/0134506	A1 *	5/2019	Gupta	G09B 19/0038
2019/0168081	A1 *	6/2019	Tattersfield	A63B 37/004

(Continued)

Primary Examiner — Joshua T Kennedy

(57) **ABSTRACT**

Systems and methods for playing a golf game are disclosed herein. In an embodiment, a system for playing a golf game within limited confines includes a wall unit, a floor unit, and a control unit. The wall unit is configured to display a virtual portion of the golf game. The floor unit is configured to enable a physical portion of the golf game. The control unit is programmed to use first data related the virtual portion and second data related to the physical portion to enable a golfer to play a full golf hole.

20 Claims, 26 Drawing Sheets

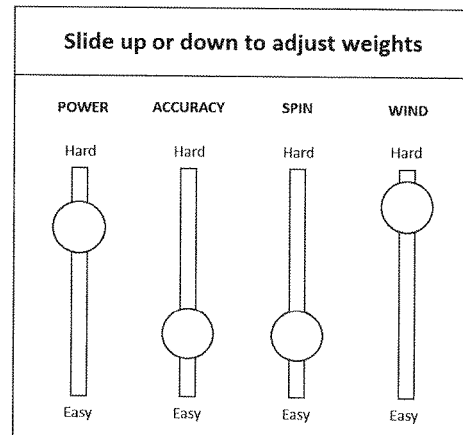
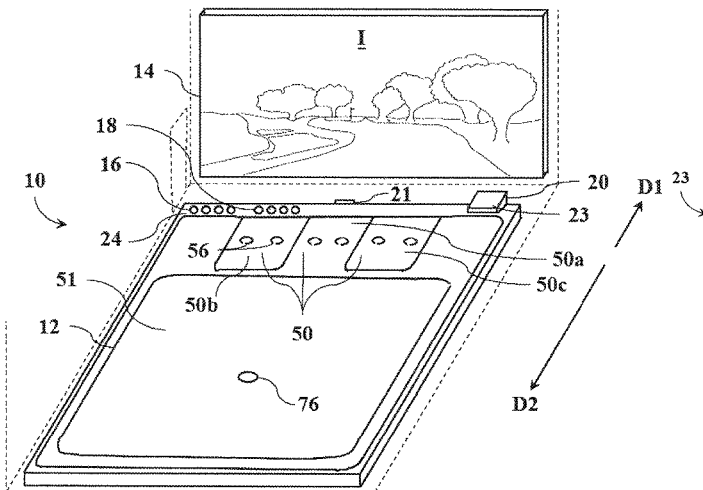

(56)

References Cited

U.S. PATENT DOCUMENTS

2019/0255407	A1*	8/2019	Rivas	A63F 13/812
2020/0206597	A1*	7/2020	Lee	G09B 5/06
2020/0330830	A1*	10/2020	Carew-Jones	A63B 43/004
2023/0087604	A1*	3/2023	Lee	A63B 69/3661
				473/155

* cited by examiner

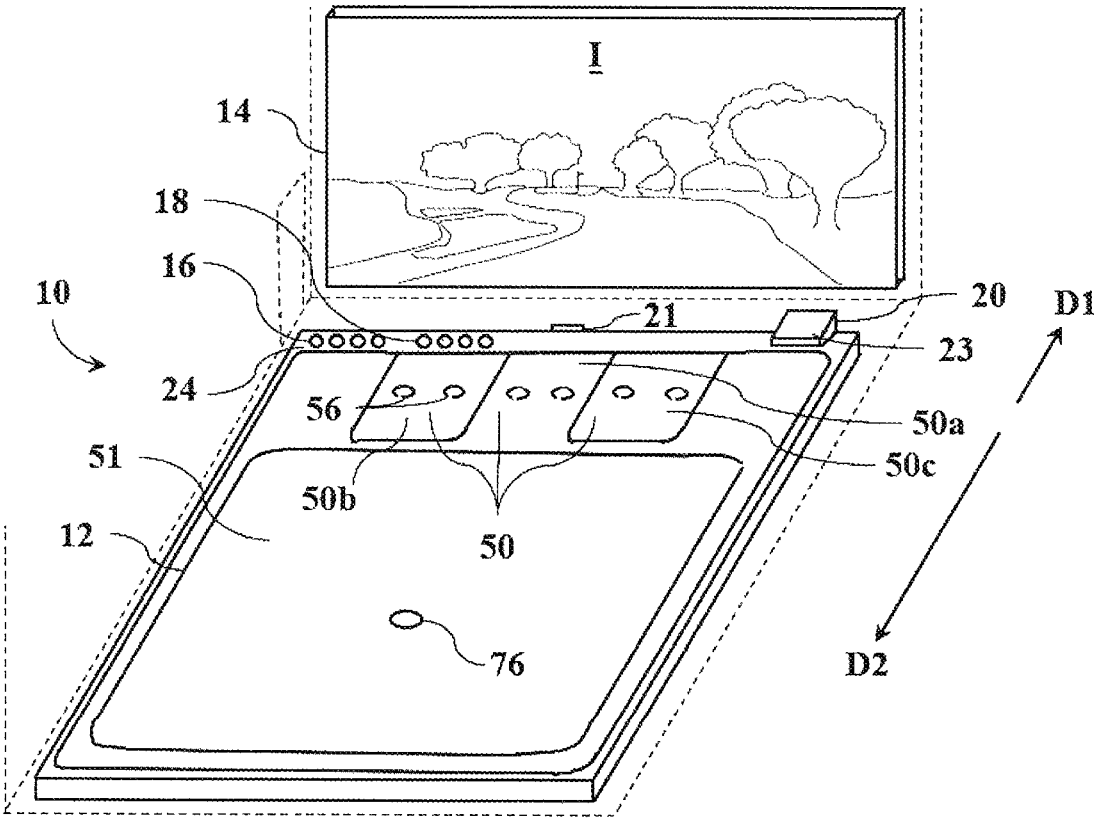

FIG. 1

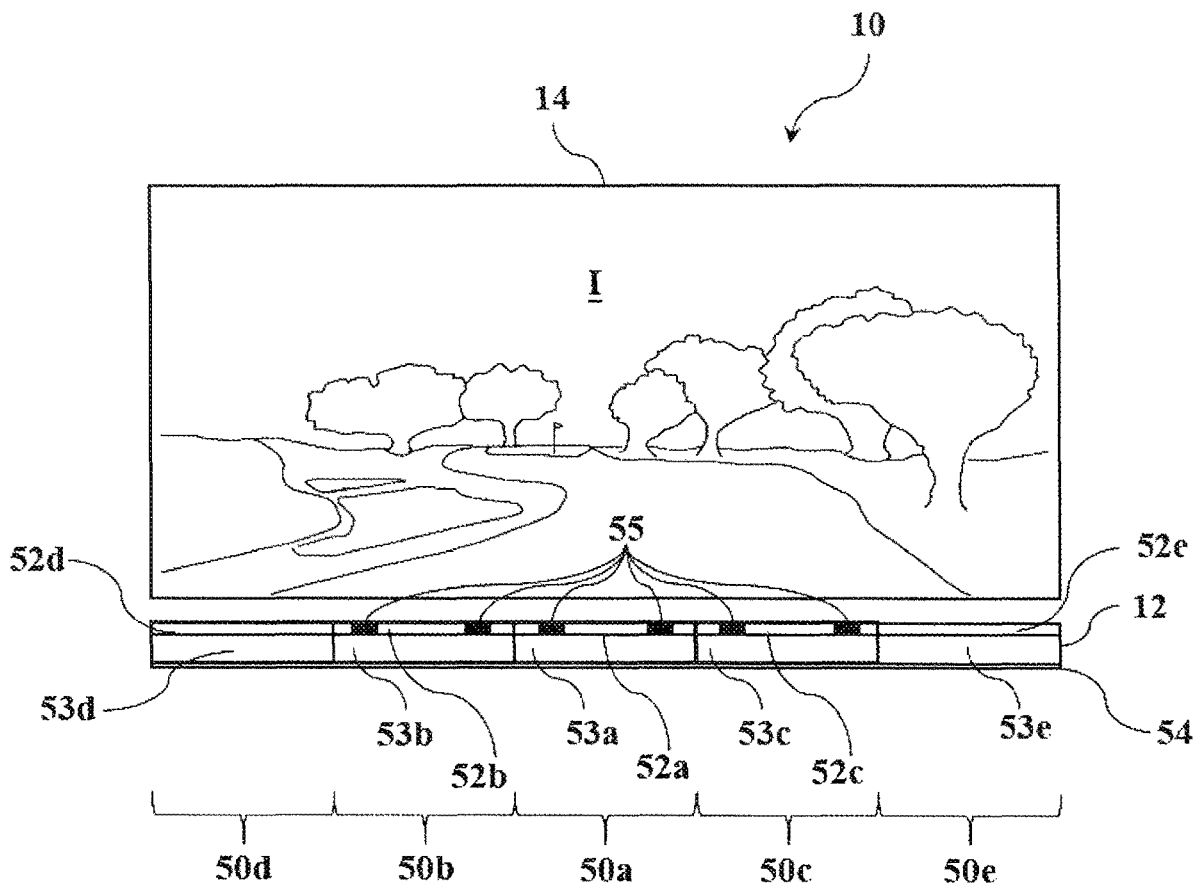

FIG. 3

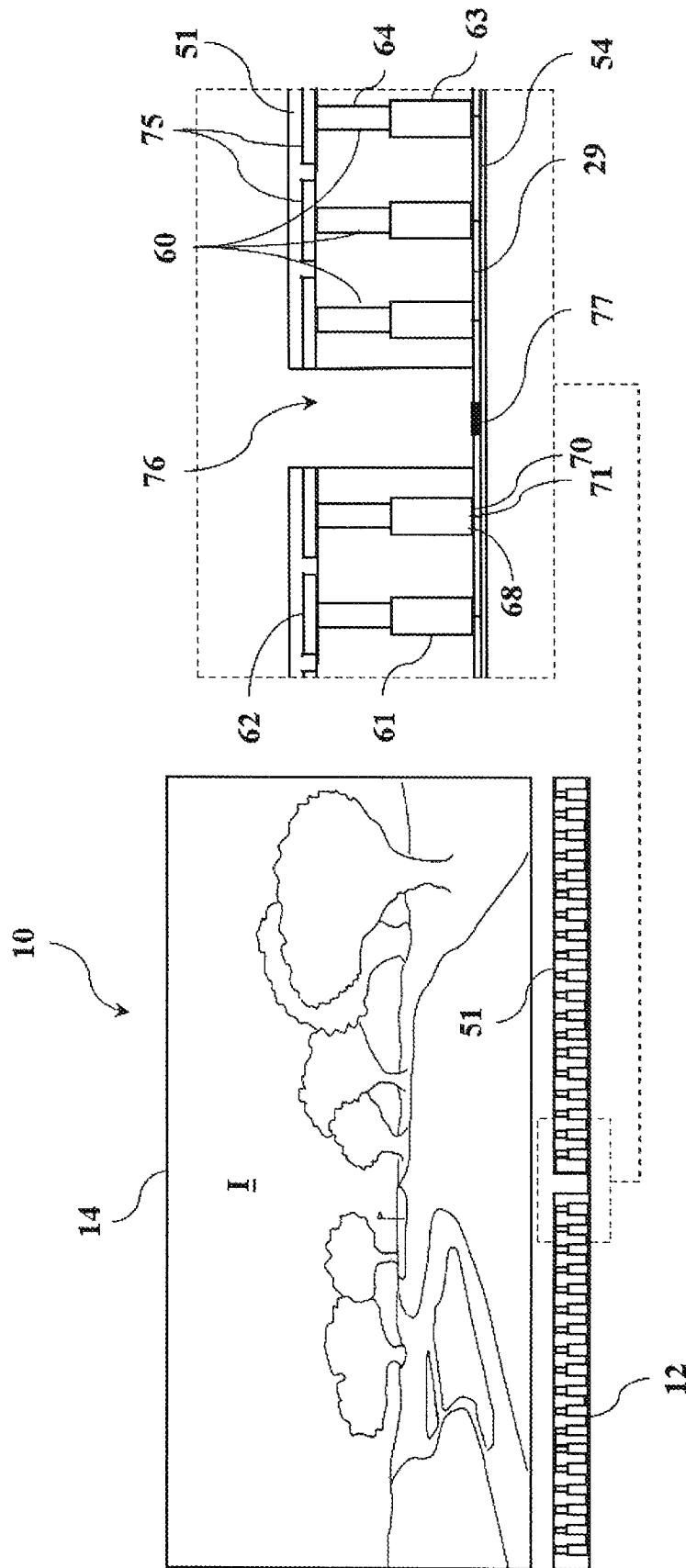

FIG. 5

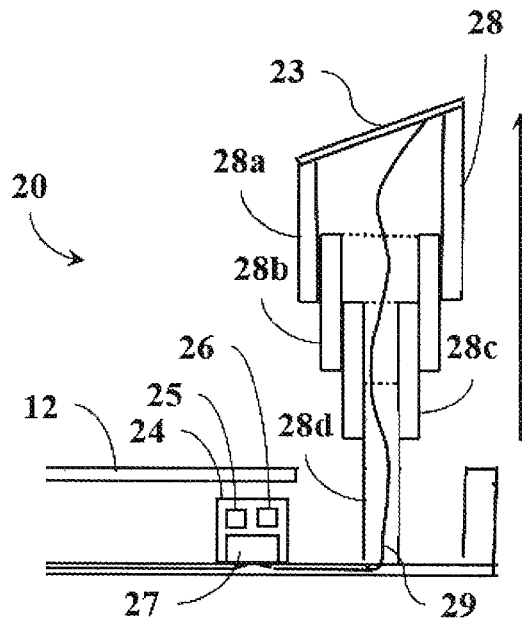

FIG. 6A

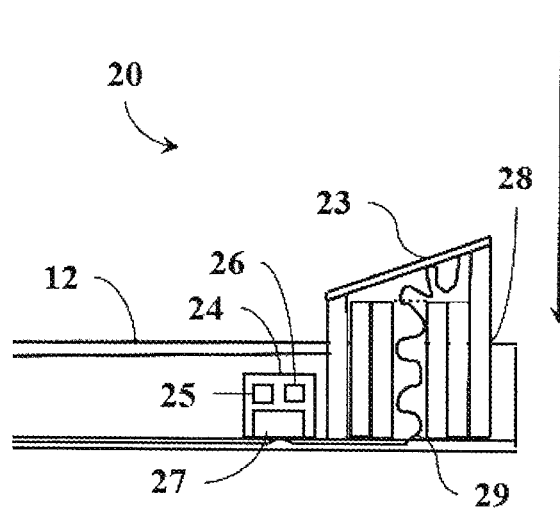

FIG. 6B

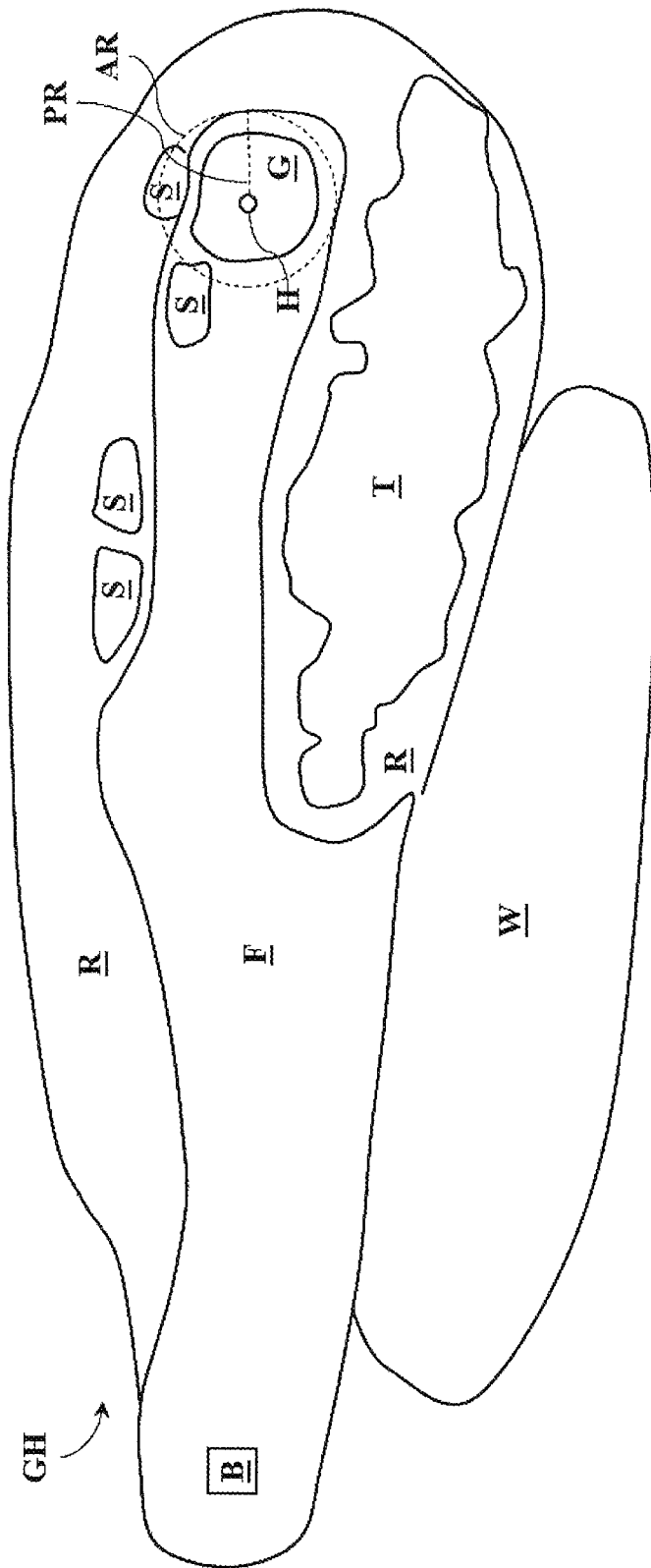

FIG. 7

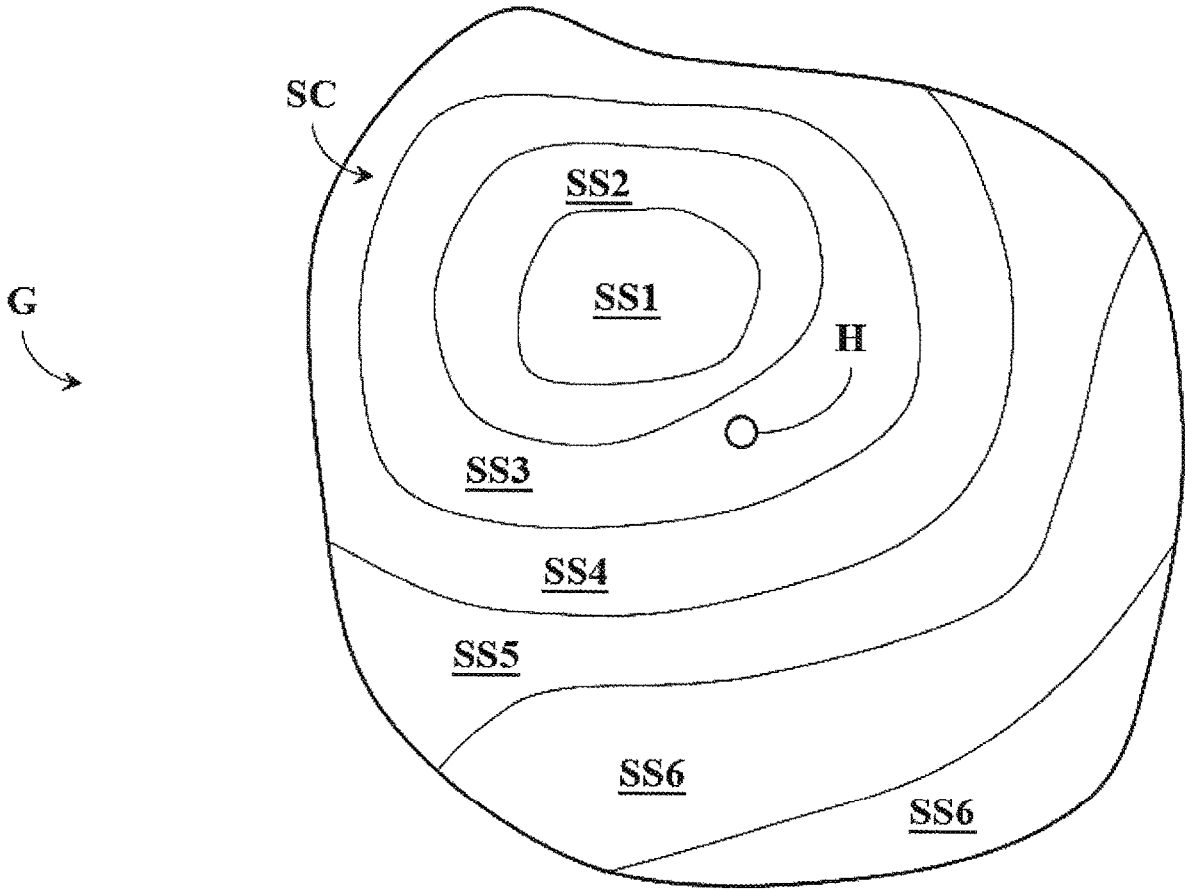

FIG. 8

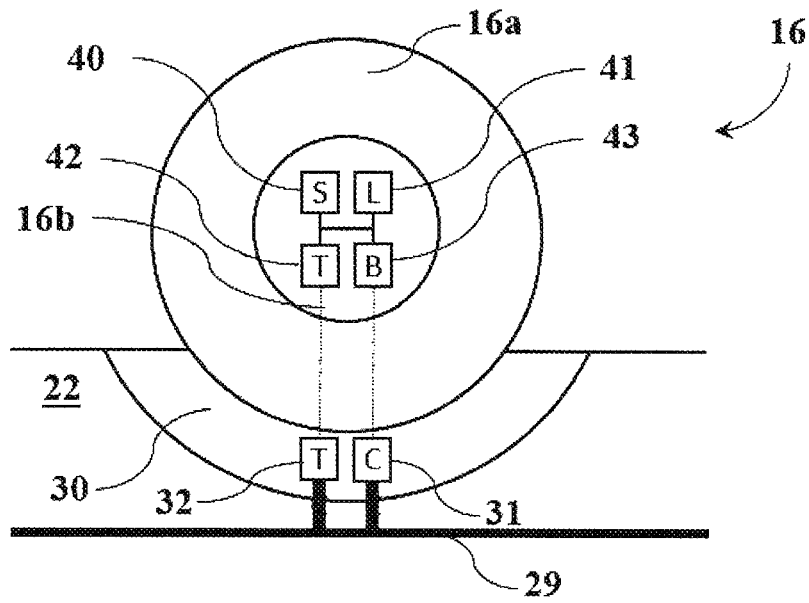

FIG. 9A

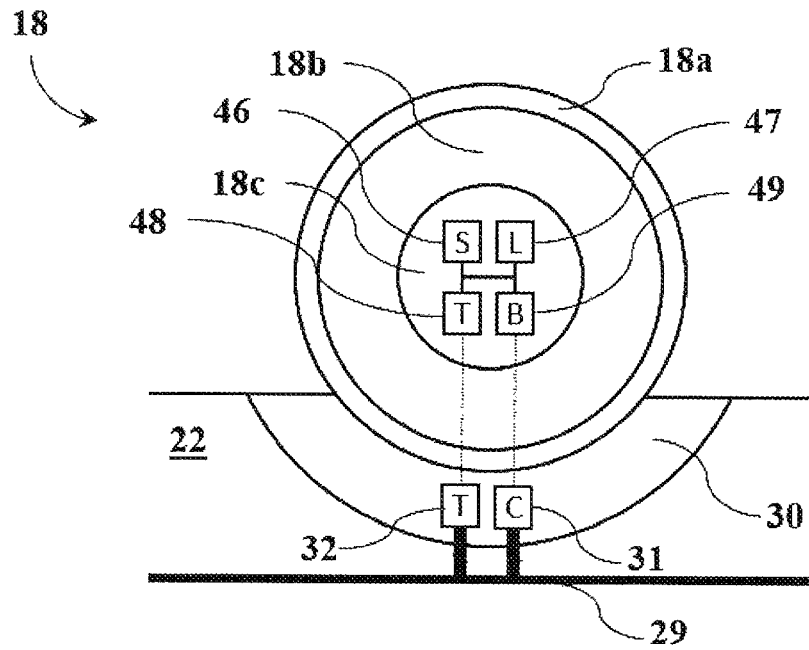

FIG. 9B

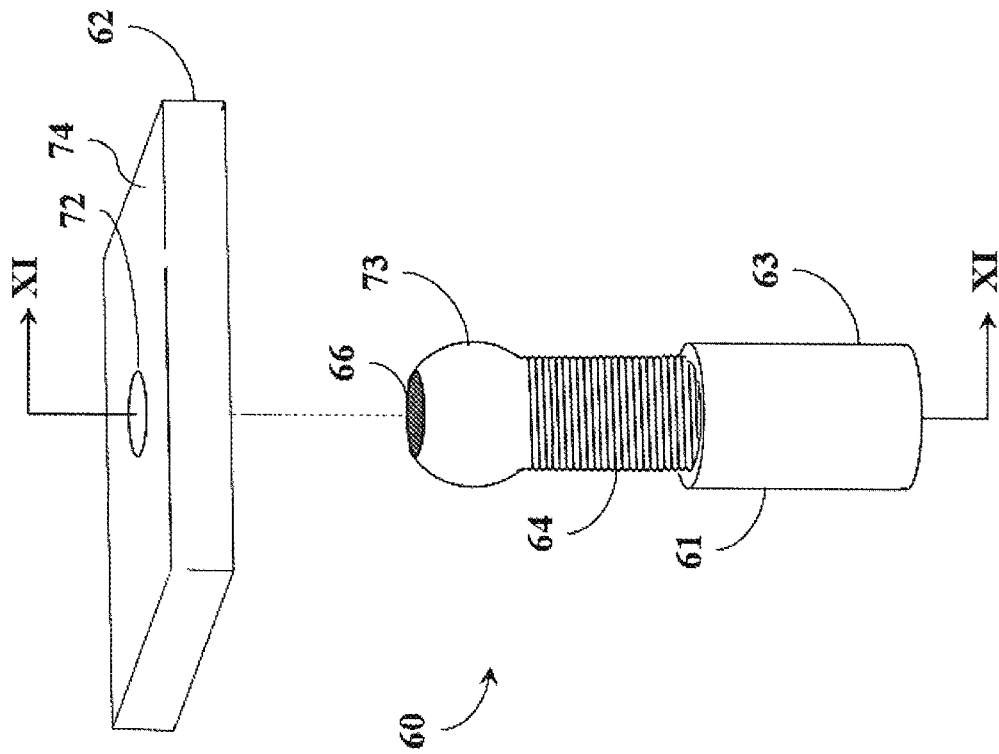

FIG. 10

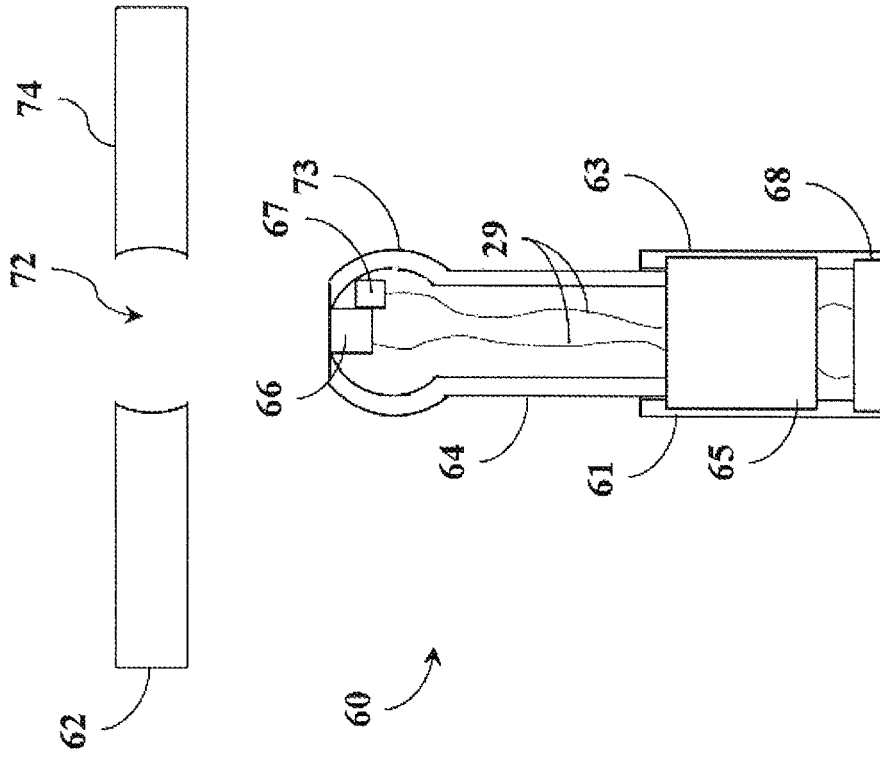

FIG. 11

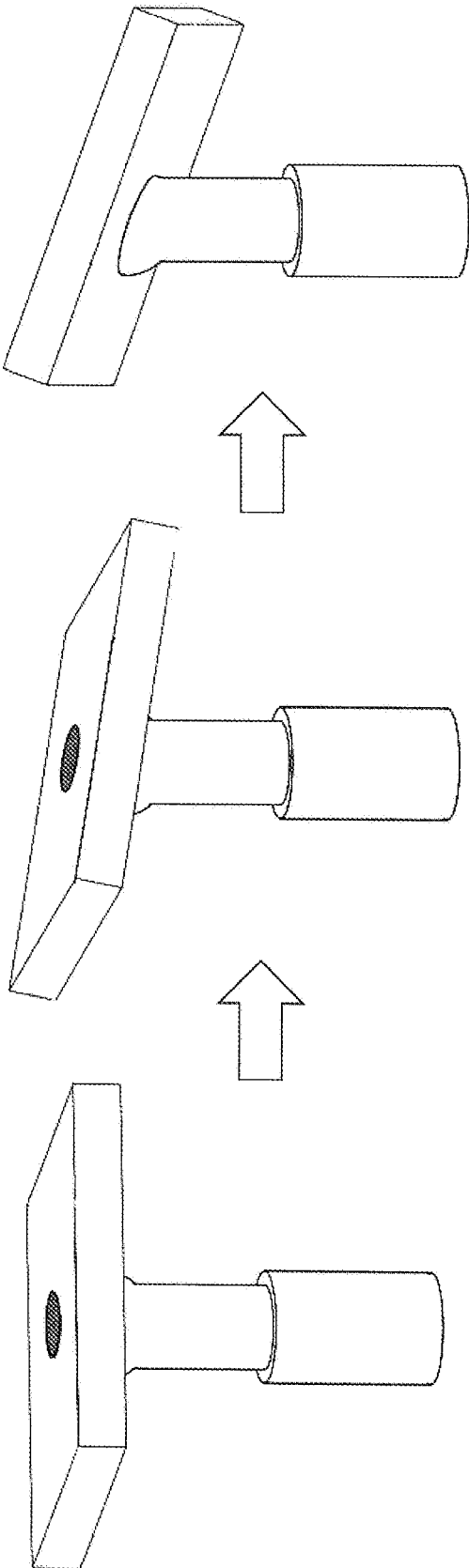

FIG. 12

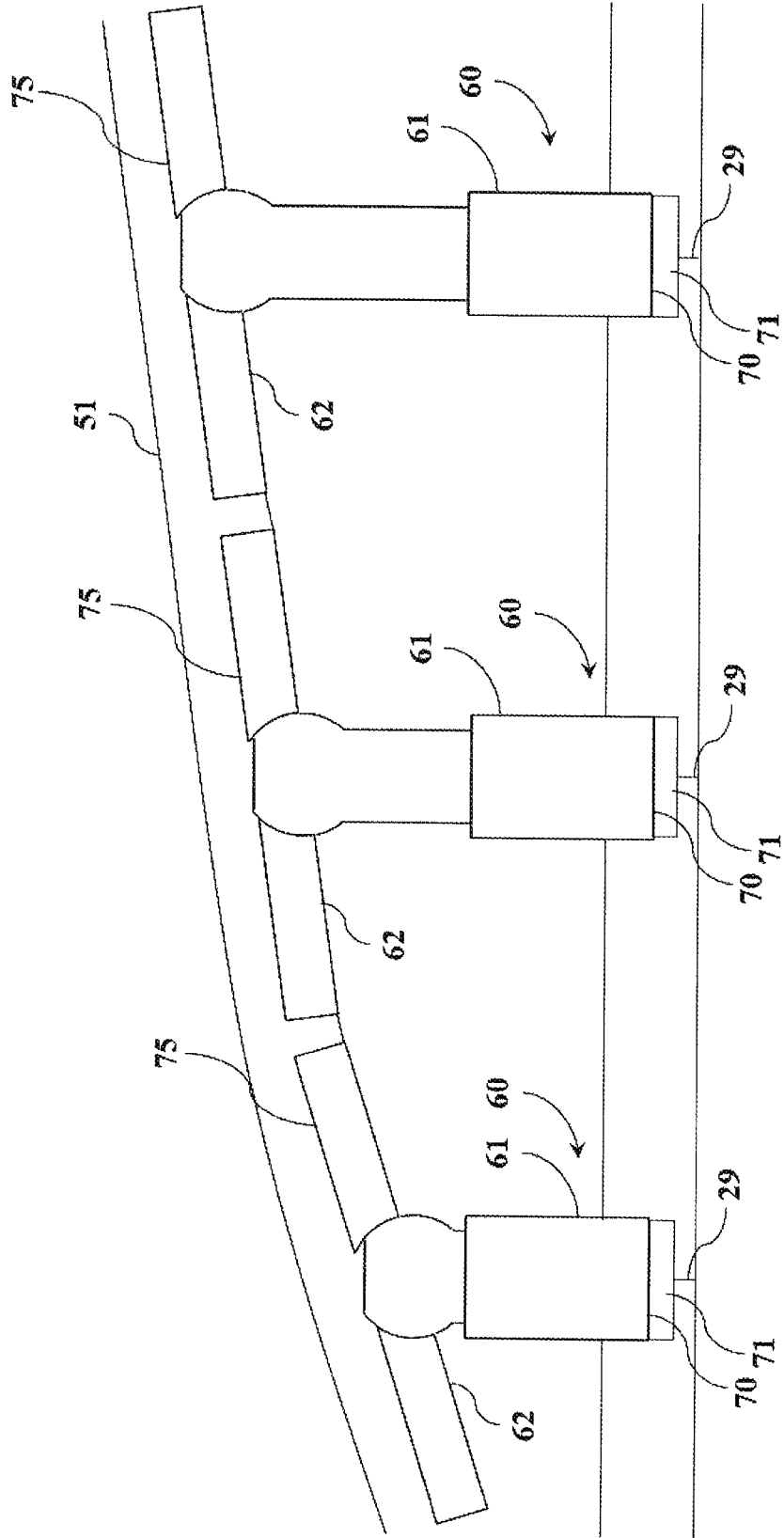

FIG. 13

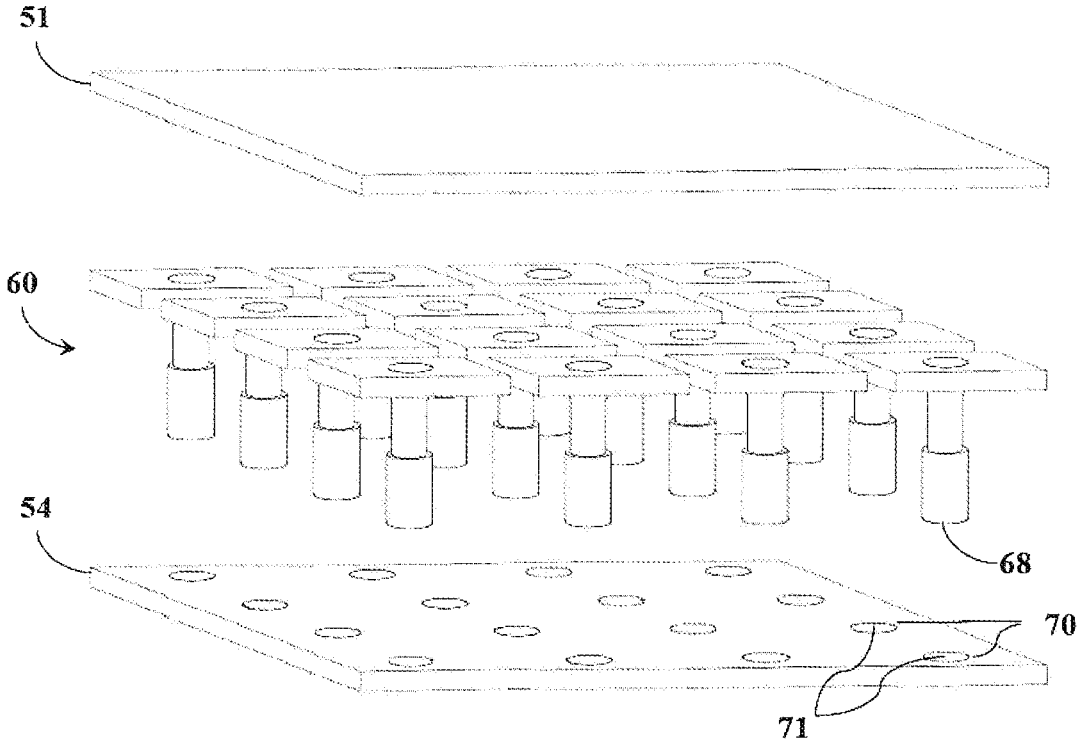

FIG. 14

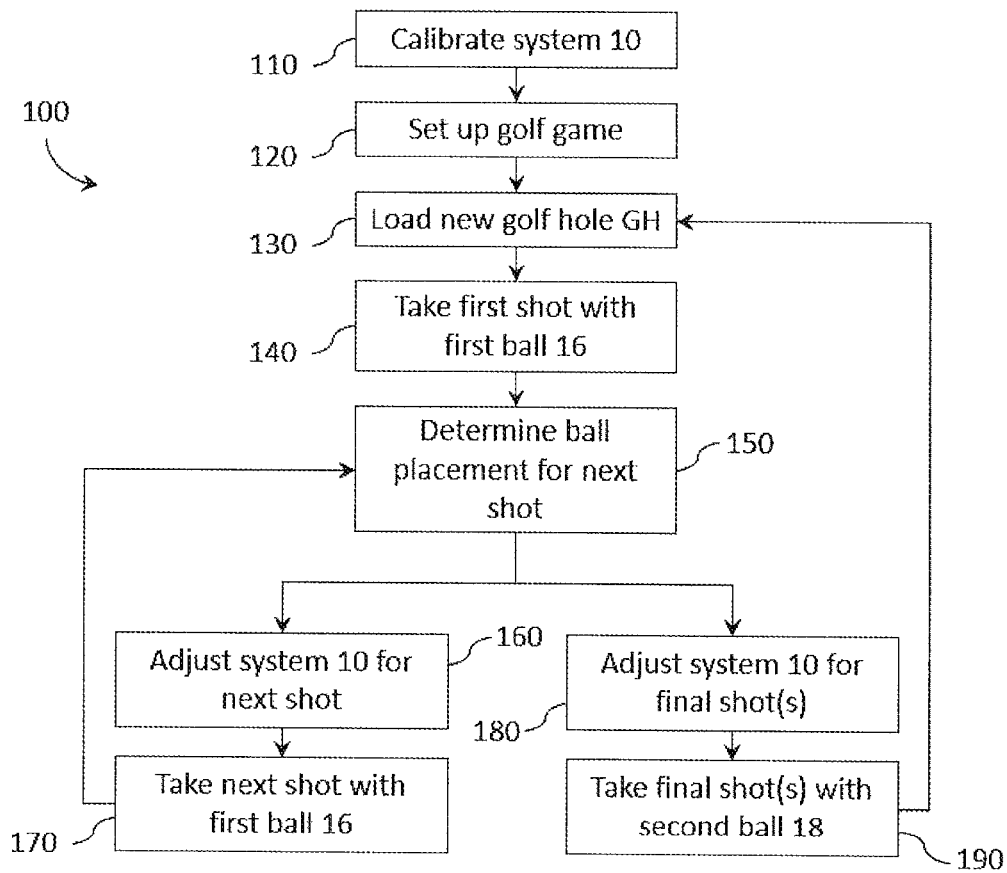

FIG. 15

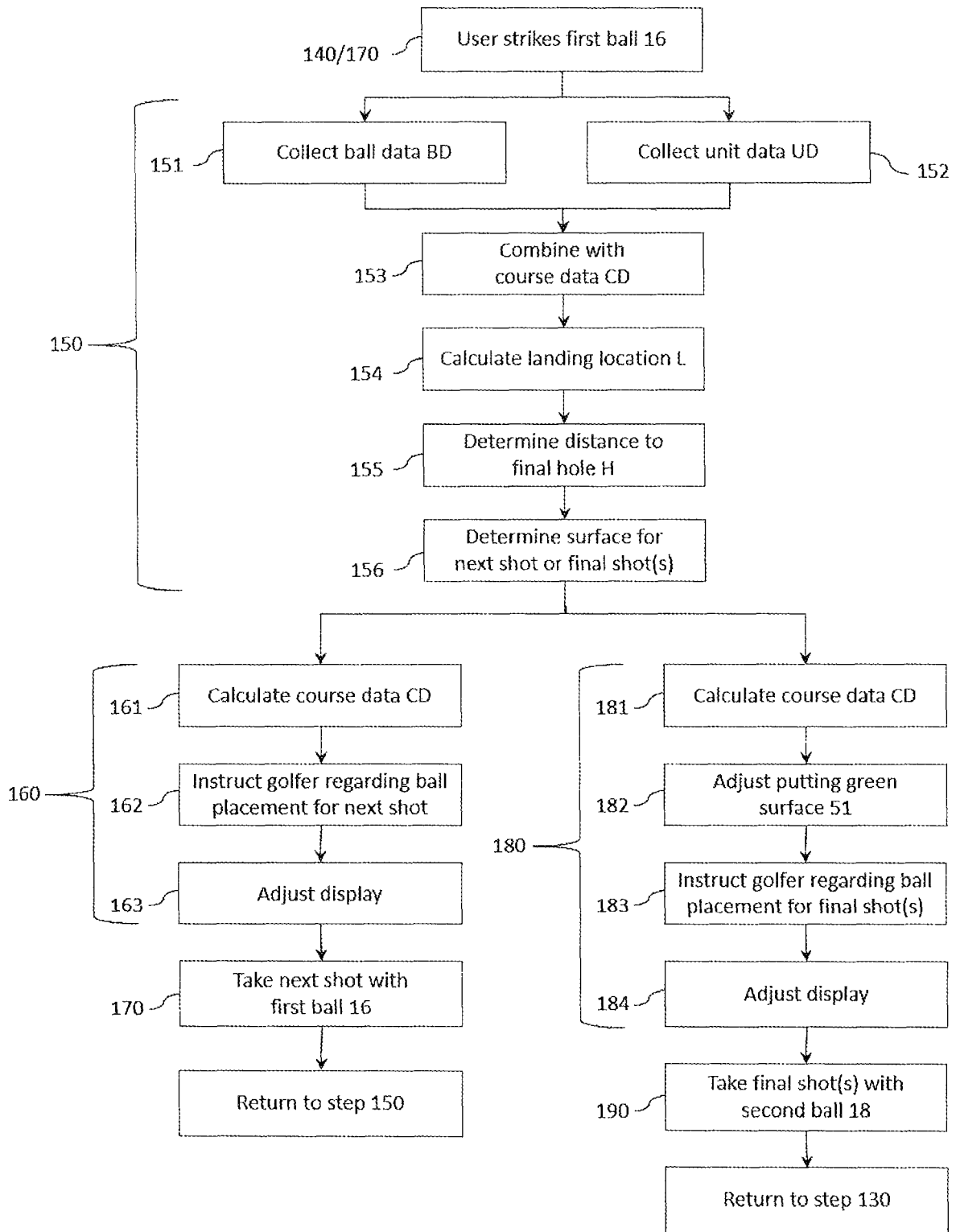

FIG. 16

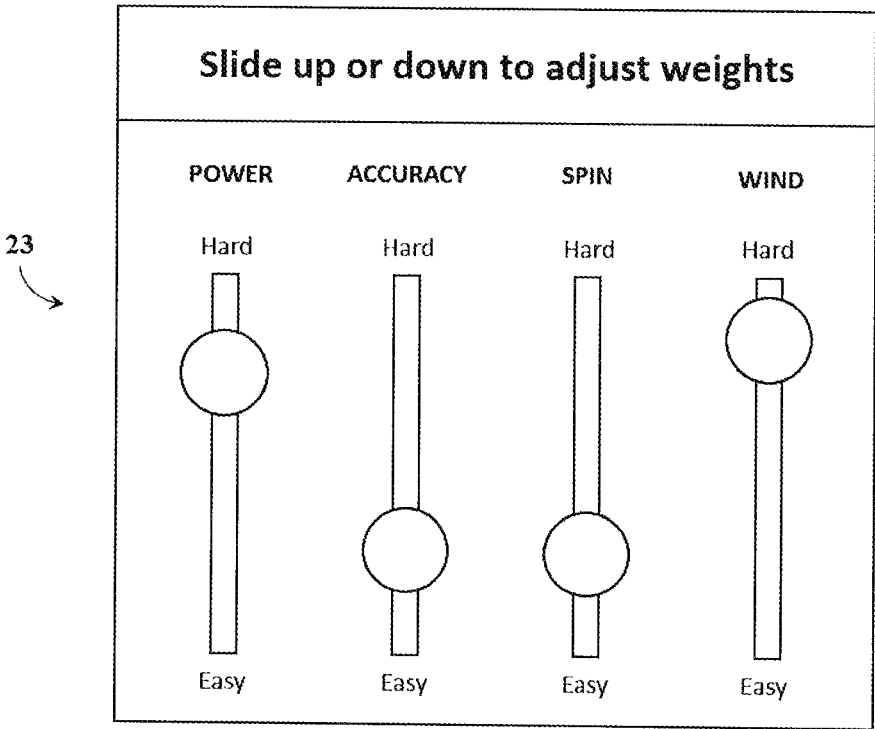

FIG. 17

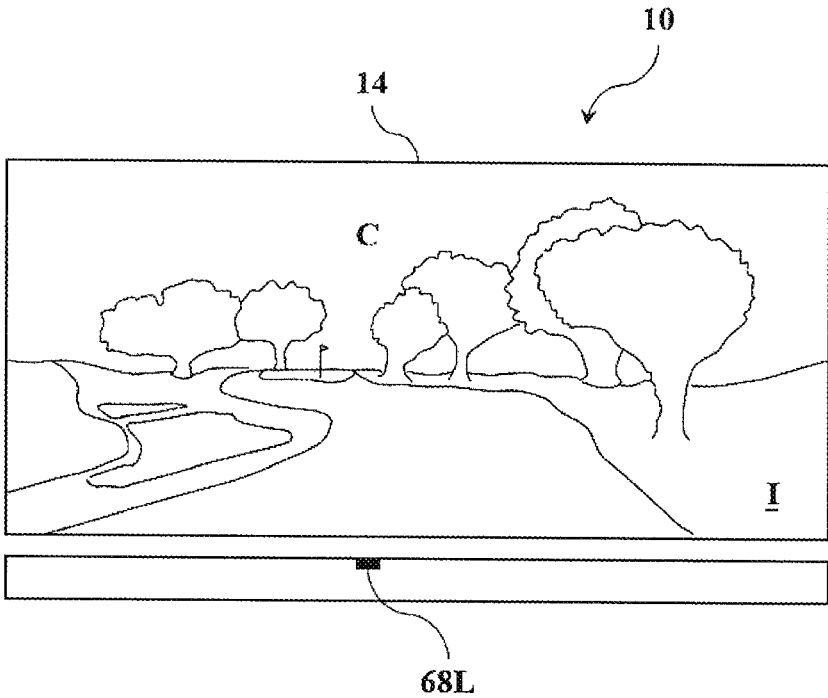

FIG. 18A

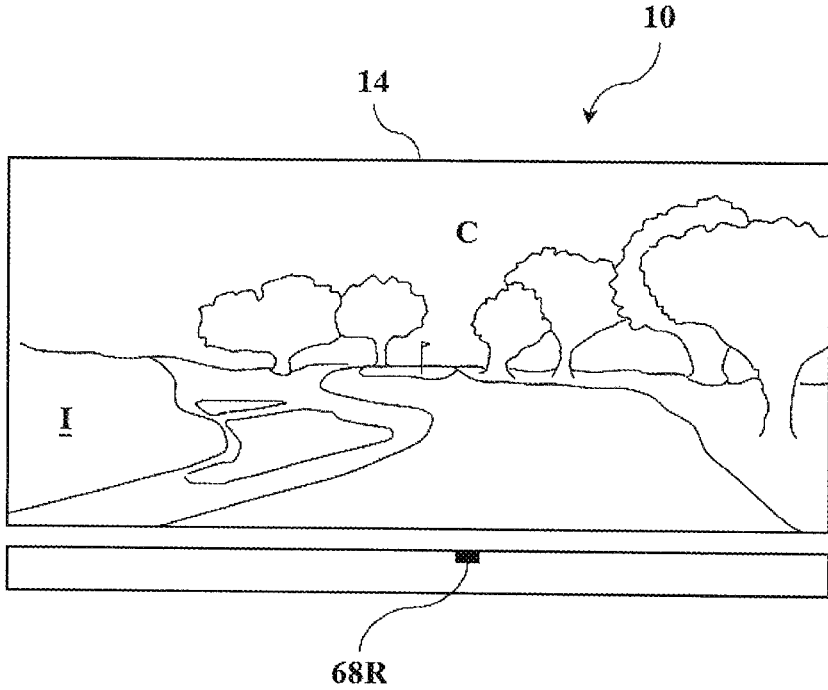

FIG. 18B

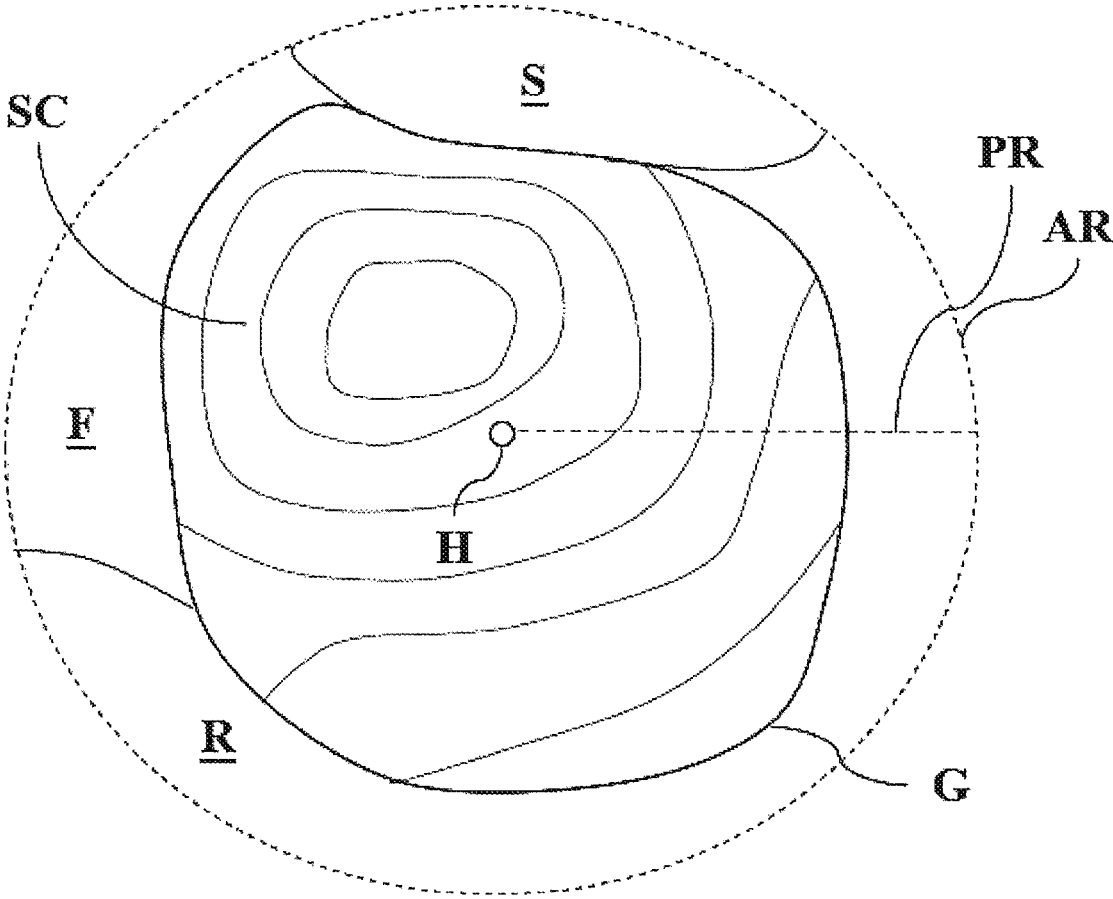

FIG. 19

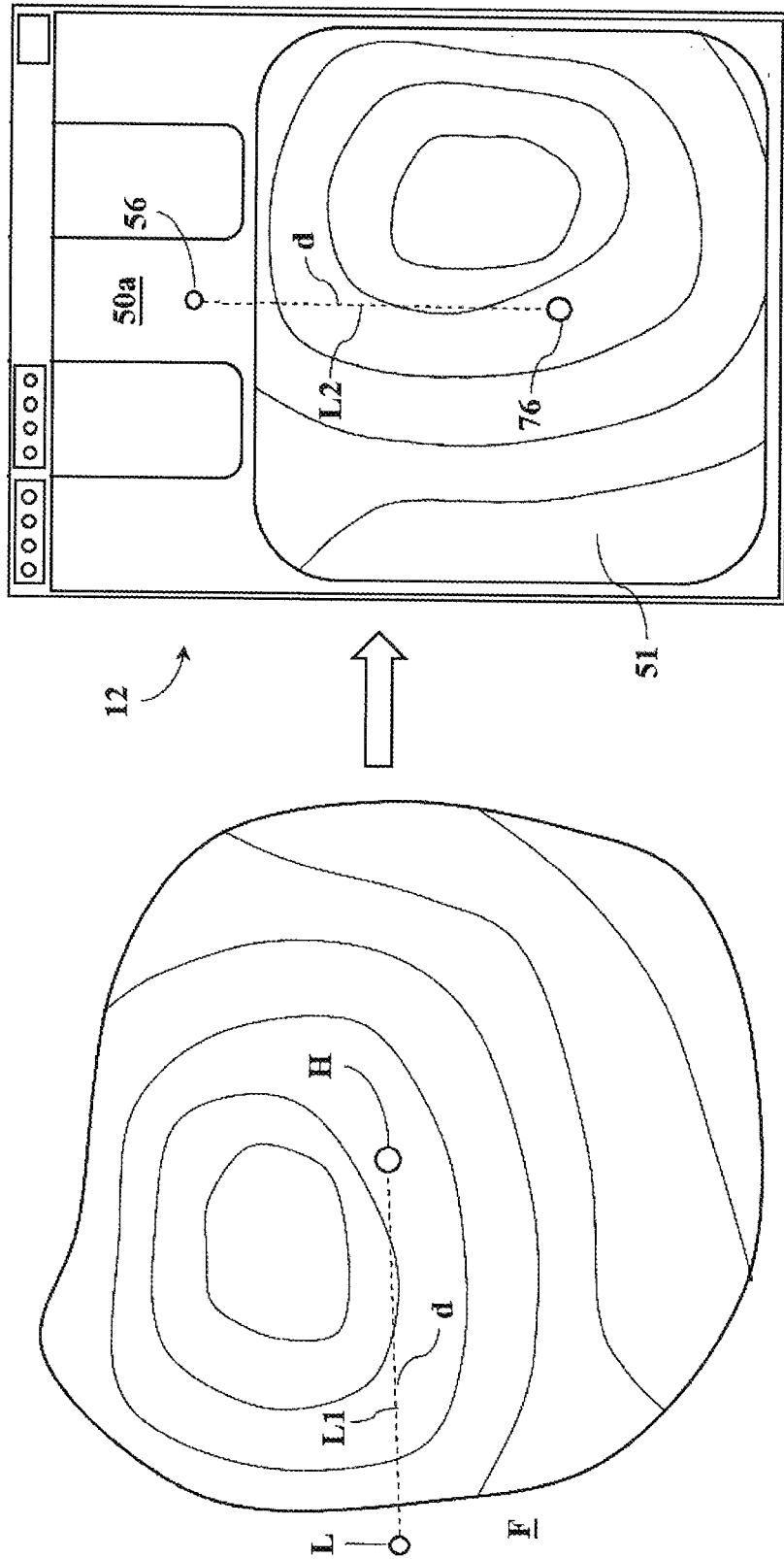

FIG. 20A

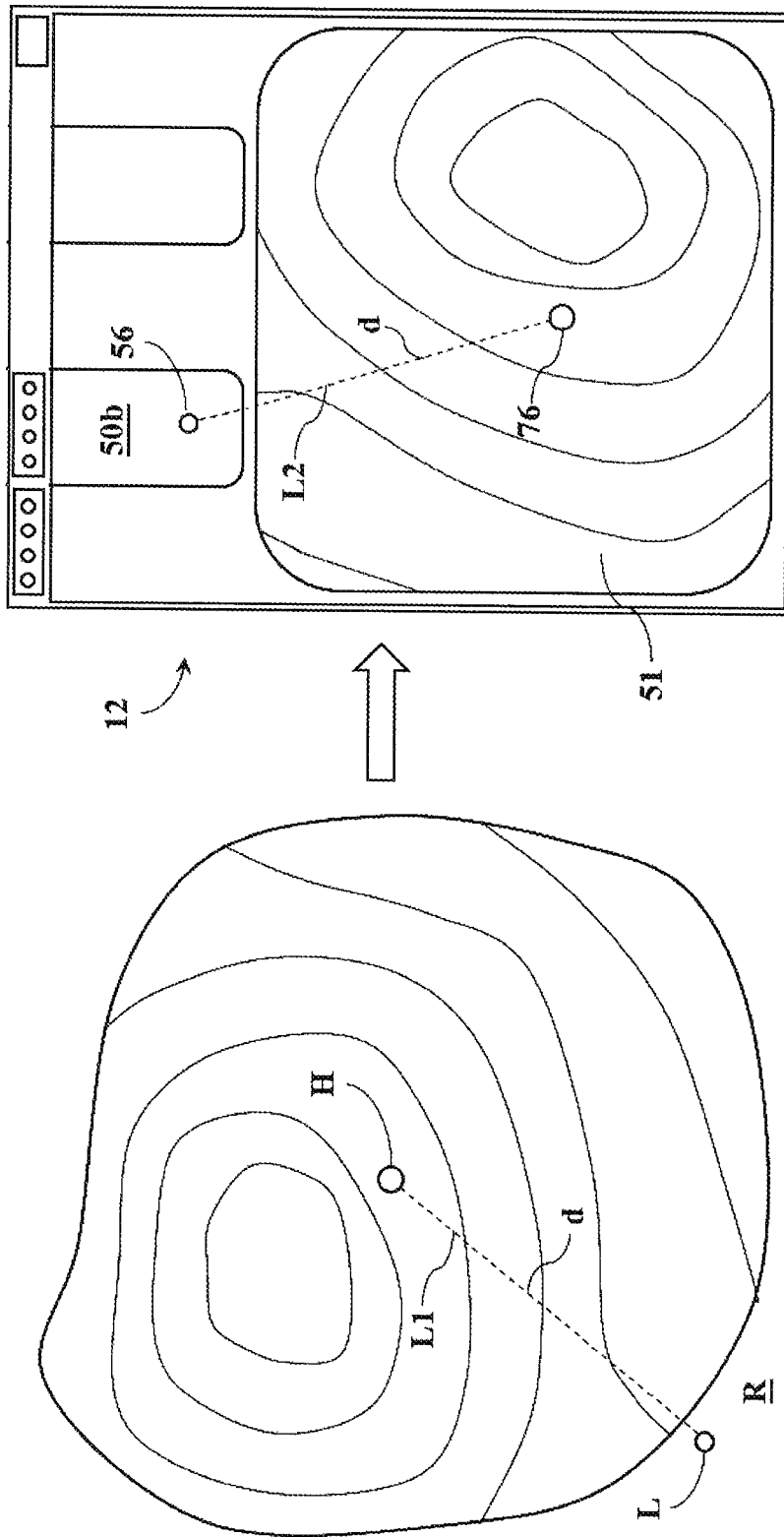

FIG. 20B

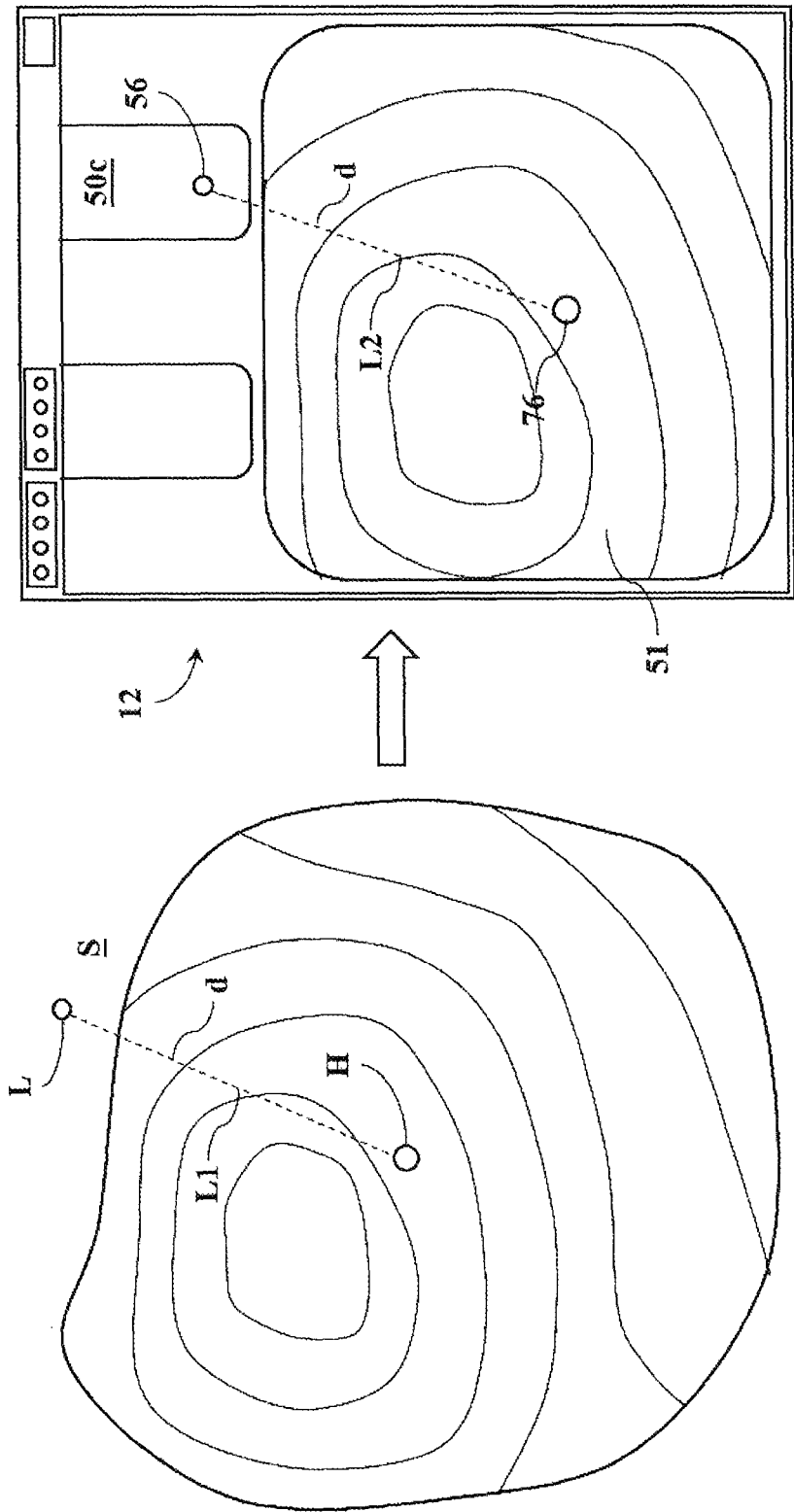

FIG. 20C

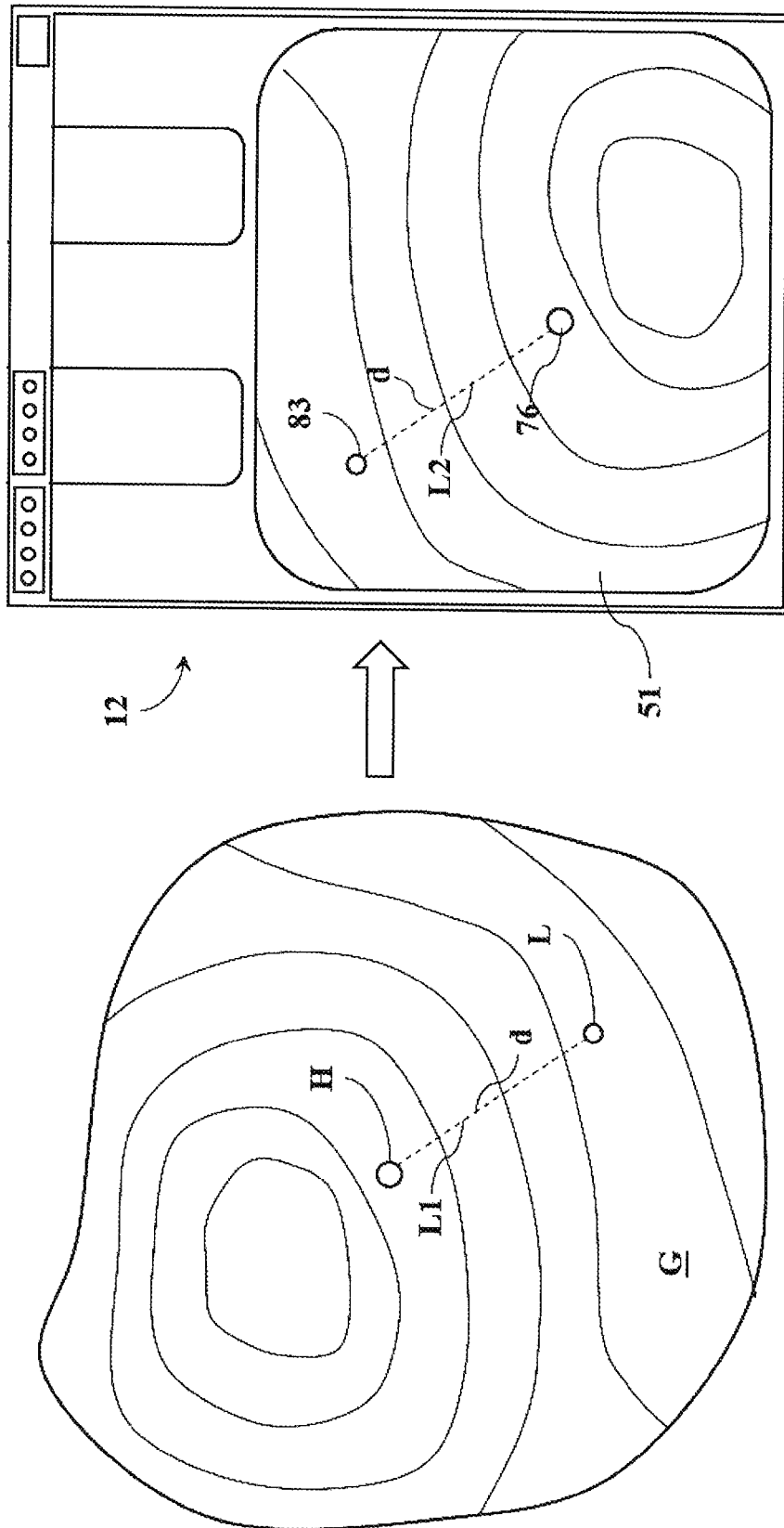

FIG. 20D

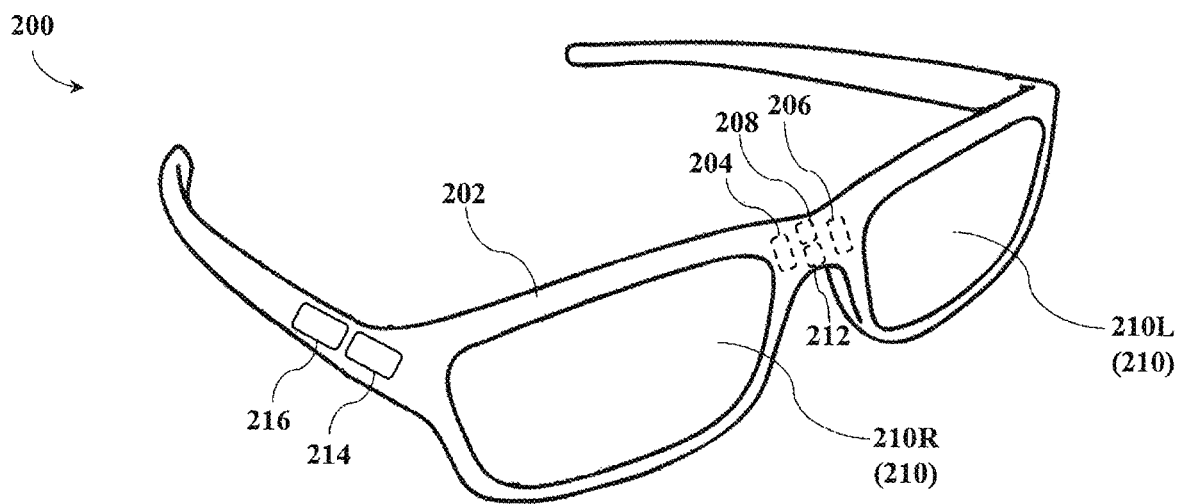

FIG. 21

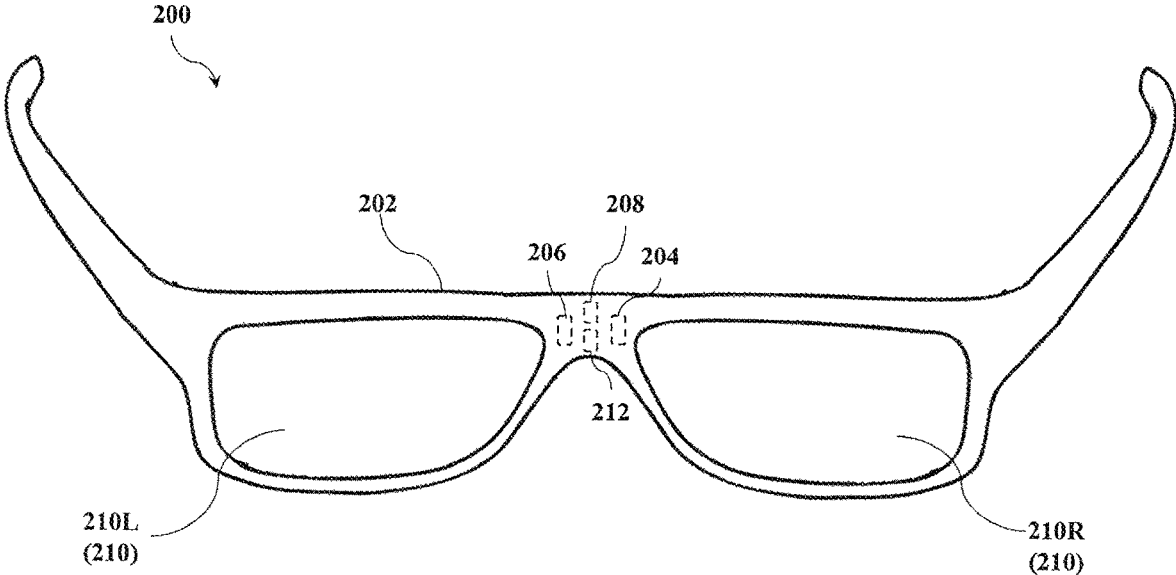

FIG. 22A

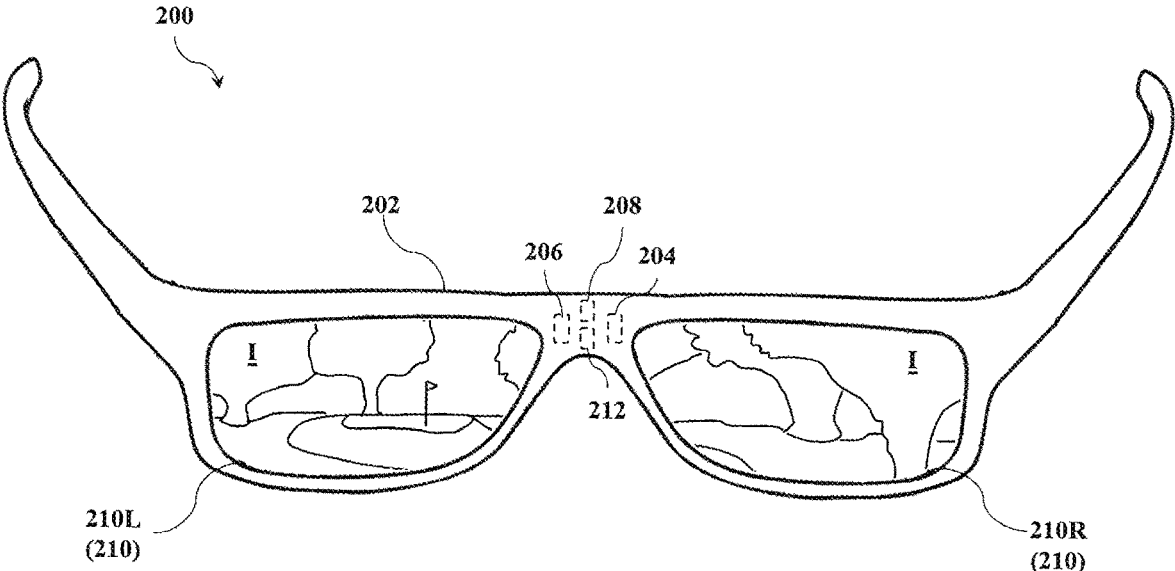

FIG. 22B

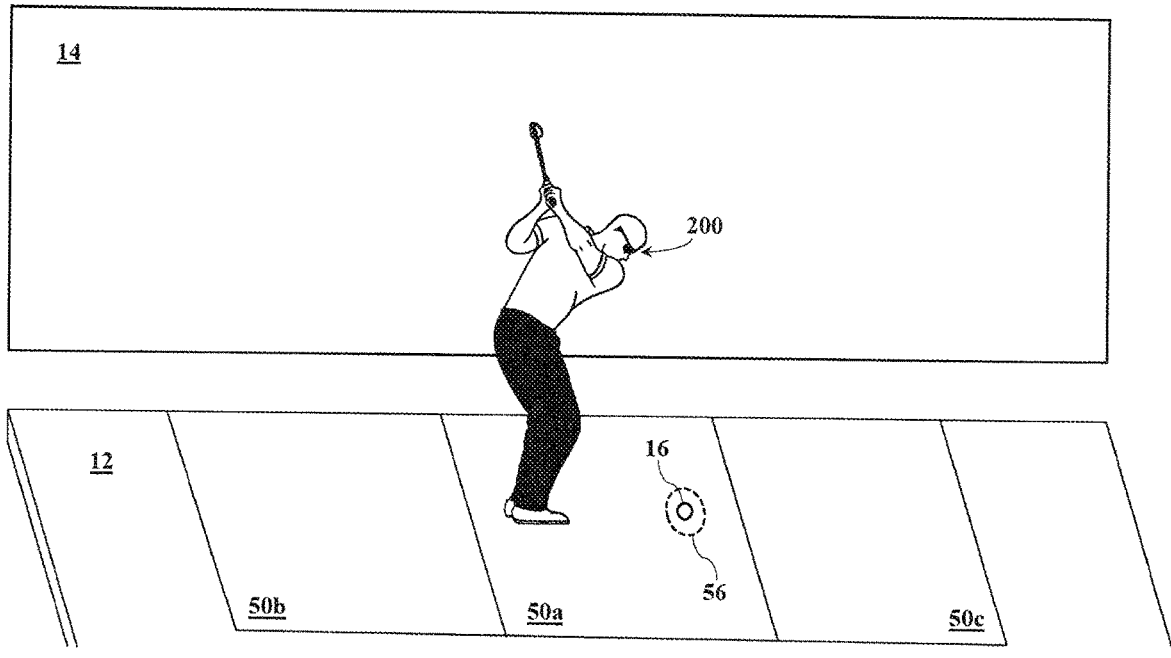

FIG. 23A

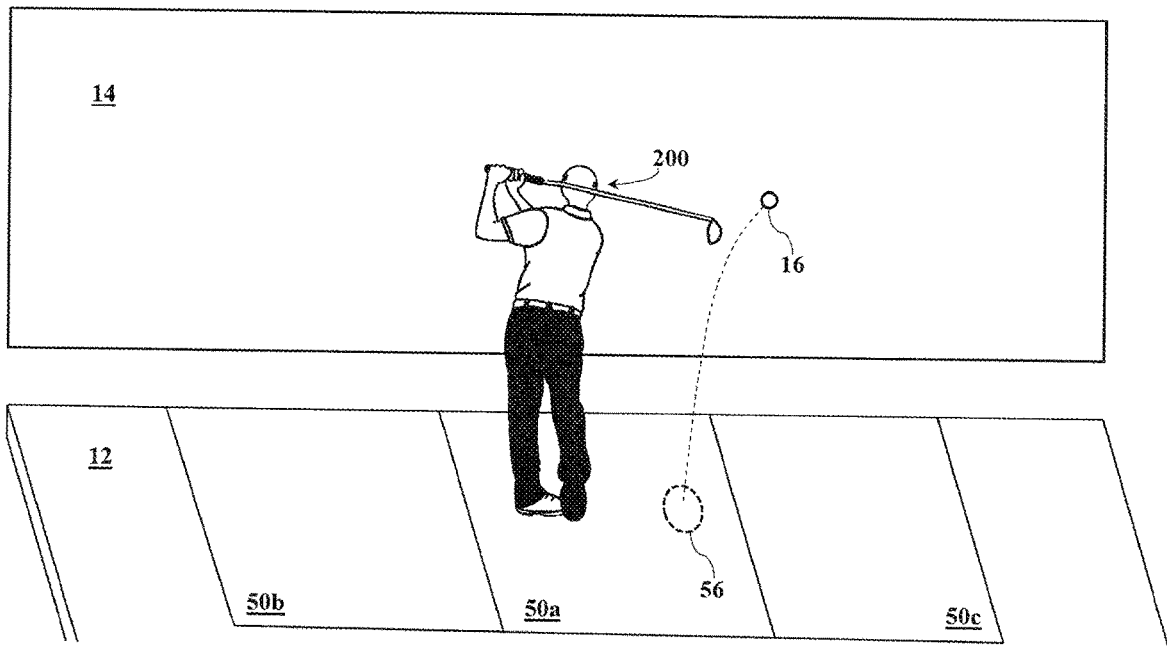

FIG. 23B

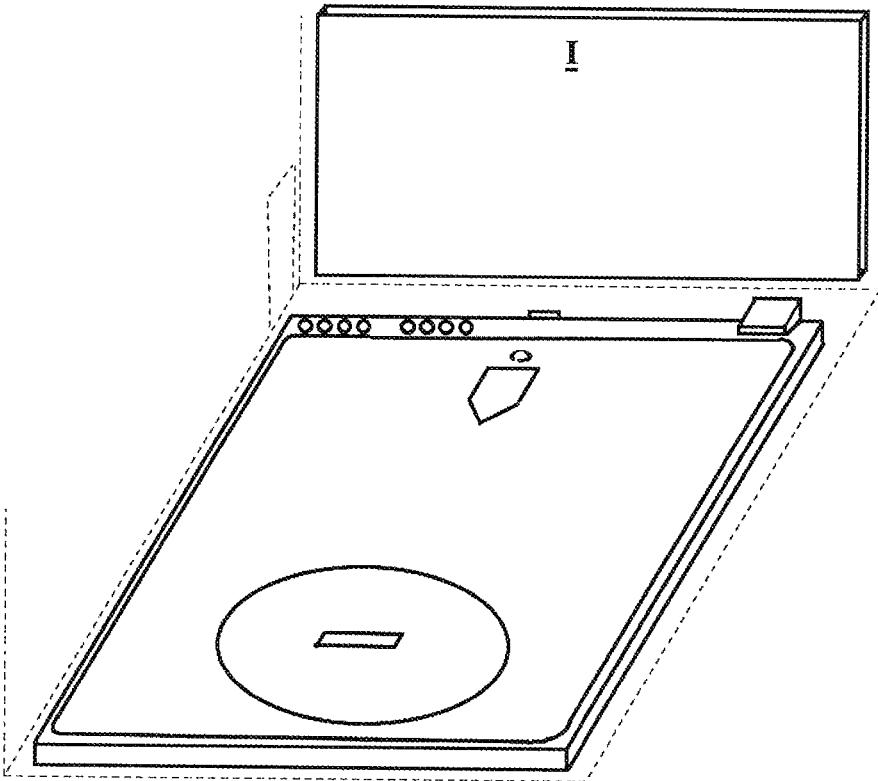

FIG. 24

SYSTEMS AND METHODS FOR PLAYING A GOLF GAME WITHIN LIMITED CONFINES

PRIORITY

This application claims priority to U.S. Provisional Application No. 63/087,387, filed Oct. 5, 2020, and U.S. Provisional No. 63/138,416, filed Jan. 16, 2021, both entitled "Systems and Methods for Playing a Golf Game within Limited Confines," the entire contents of each of which is incorporated herein by reference and relied upon.

TECHNICAL FIELD

This disclosure generally relates to systems and methods for playing a golf game. More specifically, the present disclosure relates to systems and methods which combine virtual and physical elements to enable a golfer to play all or a portion of full golf holes, from tee shot to final putt, within the limited confines of a small room or outdoor space.

BACKGROUND

Some people enjoy golf. They may not be good at it, but they still enjoy it. Others seem to hate it, but for some reason they keep playing anyway.

SUMMARY

The present disclosure provides systems and methods for playing a golf game within limited confines. In a first example embodiment, the system includes a wall unit, a floor unit, and a control unit. The wall unit is configured to display a virtual portion of the golf game. The floor unit is configured to enable a physical portion of the golf game. The control unit is programmed to use first data related the virtual portion and second data related to the physical portion to enable a golfer to play a full golf hole.

In a second example embodiment, a system for playing a golf game within limited confines includes a wall unit, a floor unit, a first ball, and a second ball. The wall unit is configured to display a virtual portion of the golf game. The floor unit is configured to enable a physical portion of the golf game. The first ball is configured to be hit by the golfer from the floor unit into the wall unit. The second ball is configured to be putted by the golfer on the floor unit.

In a third example embodiment, a method for playing a golf game within limited confines includes generating a virtual golf hole, calculating a flight path of at least one ball physically hit by the golfer during a first shot related to the virtual golf hole, and instructing the golfer where to place the at least one ball for a second shot related to the virtual golf hole.

In a fourth example embodiment, a method for playing a golf game within limited confines includes generating a virtual golf hole, calculating a landing location related to the virtual golf hole based on of a first shot physically hit by the golfer, and adjusting a putting green surface based on a landing location so that the golfer can physically hit a second shot using the putting green surface.

In a fifth example embodiment, a method for playing a golf game within limited confines includes generating a virtual golf hole, after a golfer physically hits a first ball from a floor unit into a wall unit, calculating a landing location related to the virtual golf hole, and adjusting the floor unit for use with a second ball, which is different from the first ball, based on the landing location.

In a sixth example embodiment, a floor unit for playing a golf game within limited confines includes a hitting portion including at least one hitting surface, a putting portion including a putting green surface, and a control portion configured to adjust the putting green surface.

In a seventh example embodiment, a wall unit for playing a golf game within limited confines includes a display portion configured to display a virtual portion of the golf game, and a sensor portion configured to generate data related to a physical portion of the golf game, the generated data being used to adjust display of the virtual portion.

In an eighth example embodiment, a putting green surface adjuster, which is configured to adjust a surface contour of a putting green surface in combination with other putting green surface adjusters, includes a base portion configured to adjust in height, and a surface supporting portion configured to support the putting green surface, the surface supporting portion further configured to rotate and/or tilt with respect to the base portion.

In a ninth example embodiment, a headset configured for playing a golf game within limited confines includes a frame configured to be positioned on a golfer's head and at least one display screen configured to display a virtual portion of the golf game to the golfer while the golfer plays a physical portion of the golf game.

Other objects, features, aspects and advantages of the systems and methods disclosed herein will be apparent to those skilled in the art from the following detailed description, which taken in conjunction with the annexed drawings, discloses exemplary embodiments of the disclosed systems and methods.

BRIEF DESCRIPTION OF THE DRAWINGS

Referring now to the attached drawings which form a part of this original disclosure:

FIG. 1 illustrates a top perspective view of an example embodiment of a system for playing a golf game in accordance with the present disclosure;

FIG. 2 illustrates a top plan view of the system of FIG. 1; FIG. 3 illustrates a cross-sectional side view of the system of FIGS. 1 and 2, which is taken through line III-III in FIG. 2;

FIG. 4 illustrates a cross-sectional side view of the system of FIGS. 1 to 3, which is taken through line IV-IV in FIG. 2;

FIG. 5 illustrates a cross-sectional side view of the system of FIGS. 1 to 4, which is taken through line V-V in FIG. 2;

FIG. 6A illustrates a cross-sectional side view of an example embodiment of a control center which can be used with the system of FIGS. 1 to 5, the control center shown in an extended configuration;

FIG. 6B illustrates a cross-sectional side view of the control center of FIG. 6A in a retracted configuration;

FIG. 7 illustrates an example embodiment of a virtual golf hole which can be generated by the system of FIGS. 1 to 5;

FIG. 8 illustrates an example embodiment of the virtual putting green of the virtual golf hole of FIG. 7;

FIG. 9A illustrates a schematic diagram of an example embodiment of a first ball which can be included in or utilized by the system of FIGS. 1 to 5;

FIG. 9B illustrates a schematic diagram of an example embodiment of a second ball which can be included in or utilized by the system of FIGS. 1 to 5;

FIG. 10 illustrates an exploded perspective view of a putting green surface adjuster which can be included in the system of FIGS. 1 to 5;

FIG. 11 illustrates a cross-sectional side view of the putting green surface adjuster of FIG. 10, which is taken through line XI-XI in FIG. 10;

FIG. 12 illustrates the adjustment of the surface supporting portion of the putting green surface adjuster of FIG. 10;

FIG. 13 illustrates an example embodiment of a plurality of putting green surface adjusters creating a unique surface contour for the putting green surface of the system of FIGS. 1 to 5;

FIG. 14 illustrates an exploded perspective view of a plurality of putting green surface adjusters located between a putting green surface and an electrical layer of the system of FIGS. 1 to 5;

FIG. 15 illustrates an example embodiment of a method for playing a golf game in accordance with the present disclosure, which can be used with the system of FIGS. 1 to 5;

FIG. 16 illustrates a more detailed example embodiment of several of the steps of the method of FIG. 15;

FIG. 17 illustrates an example embodiment of the display of a user interface of the system of FIGS. 1 to 5 during the method of FIG. 15 or 16;

FIGS. 18A and 18B illustrate example embodiments of how the image on a wall unit of the system of FIGS. 1 to 5 can be shifted based on where a golfer places a golf ball;

FIG. 19 illustrates an example embodiment of a virtual putting green G and its surface contour;

FIGS. 20A to 20D illustrate an example embodiment of how the system of FIGS. 1 to 5 can adjust its putting green surface to reflect a specific surface contour in accordance with the method of FIG. 15 or 16;

FIG. 21 illustrates an outside perspective view of an example embodiment of a headset which can be used alone, as part of or in conjunction with the systems and methods described herein;

FIGS. 22A and 22B illustrate an inside view of the headset of FIG. 21 from the perspective of a golfer wearing the headset;

FIGS. 23A and 23B illustrate an example embodiment of a golfer using the headset of FIG. 21 with the system of FIGS. 1 to 5; and

FIG. 24 illustrates an example embodiment of the systems and methods described herein being applied to another sport (e.g., baseball).

DETAILED DESCRIPTION

Selected embodiments will now be explained with reference to the drawings. It will be apparent to those skilled in the art from this disclosure that the following descriptions of the embodiments are provided for illustration only and not for the purpose of limiting the invention as defined by the appended claims and their equivalents.

The present disclosure relates to systems and methods for playing a golf game within limited confines. As used herein, a “golfer” generally refers to a user of the system 10, method 100 and/or headset 200 discussed herein, e.g., a player of a golf game using the system 10, method 100 and/or headset 200; a “golf hole” generally refers to an individual playing area on a golf course, e.g., with a complete golf hole extending from a teeing ground to a putting green; a “final hole” refers to the hole in the putting green which the golf ball enters at the end of each golf hole; a “golf course” generally refers to a group of golf holes, e.g., with a golf course typically including nine, eighteen, or twenty-seven golf holes; a “golf round” generally refers to playing a plurality of golf holes in a predetermined order, e.g., with a

golf round typically referring to playing eighteen golf holes at a golf course; a “golf competition” generally refers to competition in which a plurality of players compete against each other by playing one or more golf hole or golf round; and a “golf game” refers to a game played using one or more element of the system 10, method 100 and/or headset 200 discussed herein.

FIGS. 1 to 5 illustrate an example embodiment of a system 10 for playing a golf game in accordance with the present disclosure. In the illustrated embodiment, the system 10 includes a floor unit 12 and a wall unit 14. Using the floor unit 12 and the wall unit 14, a golfer can play a complete golf hole, a complete golf round, and/or a complete golf competition within limited confines, e.g., the confines of the room shown in broken lines in FIG. 1 or a small outdoor space. In the illustrated embodiment, the golfer can play a golf game which combines virtual and physical elements. The wall unit 14 is configured to collect data related to and/or display a virtual portion of the golf game, while the floor unit 12 is configured to enable a physical portion of the golf game and/or collect data related to the virtual portion.

In the illustrated embodiment, the system 10 includes one or more first balls 16 and one or more second balls 18. As explained in more detail below, each first ball 16 is configured for playing the beginning one or more shots of a golf hole, while each second ball 18 is configured for playing the final one or more shots of a golf hole. Thus, using a first ball 16 and a second ball 18, a golfer can play a complete golf hole, from tee shot to final putt, using the floor unit 12 and the wall unit 14. The golfer can further play a plurality of golf holes, thus completing a full golf round and/or a full golf competition using the floor unit 12 and the wall unit 14 in accordance with the methods discussed herein.

In the illustrated embodiment, the floor unit 12 includes a control portion 12a, a hitting portion 12b, and a putting portion 12c. Here, the control portion 12a is located closest to the wall unit 14. The hitting portion 12b is located between the control portion 12a and the putting portion 12c. The hitting portion 12b is also located closer to the wall unit 14 than the putting portion 12c. Those of ordinary skill in the art will recognize from this disclosure that this is an example only and that the locations of one or more of the control portion 12a, the hitting portion 12b, and/or the putting portion 12c can be altered, e.g., based on the layout of the room.

In an embodiment, during a golf hole, a golfer is enabled to physically hit a first ball 16 from the hitting portion 12b in the direction D1 towards the wall unit 14 at least once, and the golfer is enabled to physically hit a second ball 18 from the hitting portion 12b in the direction D2 towards the putting portion 12c at least once. The golfer is also enabled to physically hit a first ball 16 from the hitting portion 12b in the direction D1 towards the wall unit 14 at least once, and then physically put on the putting portion 12c using a second ball 18 at least once.

In an embodiment, the control portion 12a of the floor unit 12 includes one or more of a control center 20, an image projector 21, and/or one or more ball charging station 22. The control center 20 is configured to automatically control the image projector 21 and the one or more ball charging station 22 in addition to the other electrical components described herein and/or any other relevant electrical components.

An example embodiment of a control center 20 is illustrated in more detail in FIGS. 6A and 6B. In the illustrated embodiment, the control center 20 includes a user interface 23 and a control unit 24. The user interface 23 can include

an input device and a display. In an embodiment, the user interface **23** includes a touch screen, for example, a tablet configured to accept user input on a display screen.

In the illustrated embodiment, the control unit **24** includes a processor **25** and a memory **26**. The processor **25** is configured (i.e., programmed) to execute instructions stored on the memory **26** to enable the control unit **24** to control various elements of the system **10** as discussed herein. The processor **25** is further configured to execute instructions stored on the memory **26** to enable the control unit **24** to perform the various steps of method **100** discussed herein. The memory **26** can include a non-transitory, computer-readable medium. The control unit **24** can further include a data transmission device **27** configured to communicate with the rest of the elements of the system **10** discussed herein and/or communicate with an online central server. The data transmission device **27** can include a data bus, a wireless transceiver, and/or any other data transmission mechanism. The data transmission device **27** can be configured for wired or wireless transmission.

As illustrated by FIGS. **6A** and **6B**, in an embodiment, the user interface **23** is configured to translate between an extended configuration (FIG. **6A**) and a retracted configuration (FIG. **6B**). In the extended configuration shown in FIG. **6A**, the user interface **23** extends upwards for ease of use of a golfer to set up a golf game using the system **10**. In the retracted configuration shown in FIG. **6B**, the user interface **23** retracts towards the floor unit **12** so that the golfer does not strike the user interface **23** with a ball or club while playing a golf game. In the illustrated embodiment, the control center **20** includes a translation mechanism **28** enabling the user interface **23** to automatically or manually translate upwardly or downwardly. Here, the translation mechanism **28** includes a plurality of sections **28a**, **28b**, **28c**, **28d** which translate with respect to each other; in doing so, the plurality of sections **28a**, **28b**, **28c**, **28d** collapse into the floor unit **12**. In the illustrated embodiment, the user interface **23** is wired to the control unit **24** via wiring **29** which runs through the translation mechanism; though the user interface **23** and the control unit **24** can also be configured for wireless communication. The control unit **24** can further be wired to the other electrical elements discussed herein, for example, using similar wiring **29** as shown throughout the figures.

As explained in more detail below, in an embodiment, the control unit **24** is configured to generate one or more virtual golf hole GH to be played by one or more golfer using the system **10**. FIG. **7** illustrates an example embodiment of a virtual golf hole GH which has been generated by the control unit **24**. As will be understood by most golfers, the virtual golf hole GH includes a fairway F, a rough R, a putting green G including a final hole H, a sand trap S, a water hazard W, a tree hazard T, and a tee box B. These elements represent the typical elements found on a real golf hole, although some of these elements can be omitted for some golf holes, and additional elements can similarly be included for some golf holes.

In an embodiment, the virtual golf hole GH is a randomly created virtual golf hole GH or a prestored virtual golf hole GH. In an embodiment, the memory **26** of the control unit **24** stores a plurality of virtual golf holes GH. The prestored virtual golf holes GH can be modeled after real golf holes on real world golf courses or can be imagined golf holes that do not exist in the real world.

As illustrated in FIG. **7**, in an embodiment, the control unit **24** measures an area AR based on a predetermined radius PR from the final hole H. As explained in more detail

below, a golfer can use system **10** by physically taking one or more shots with a first ball **16** using the hitting portion **12b** until the control unit **24** determines a shot to land within the area AR. Once a shot lands within the area AR, the golfer can switch to a second ball **18** and finish the golf hole GH using the putting portion **12c** of the floor unit **12**.

FIG. **8** shows an example embodiment of the putting green G in more detail. FIG. **8** further illustrates the surface contour SC which the control unit **24** has generated for the putting green G. The surface contour SC is determined by a plurality of surface sections SS1, SS2 . . . SSn, which can have varying heights that result in each golf hole GH having a putting green G with a distinct surface contour SC. As described in more detail below, the putting green portion **12c** of the floor unit **12** can be adjusted to replicate the virtual surface contour SC of the virtual putting green G of the virtual golf hole GH.

In an embodiment, the image projector **21** is configured to project an image I onto the wall unit **14**. The image I can include an image of a virtual golf hole GI currently being played by the golfer in accordance with the methods discussed herein. More specifically, the image I can include a three-dimensional image of the virtual golf hole GH from the perspective of the golfer, e.g., from wherever the golfer's ball is located on the virtual golf hole GH. In the illustrated embodiment, the image projector **21** is located at the front and center of the control portion **12a** of the floor unit **12**, such that the image projector **21** is positioned and arranged to project the image I onto the wall unit **14**. In an embodiment, one or more image I can be displayed on a headset **200** worn by the golfer, as discussed in more detail below. In an embodiment, the headset **200** can replace the image projector **21** and/or the wall unit **14**.

FIG. **9A** illustrates an example embodiment of a first ball **16** placed within a first ball station **22**, while FIG. **9B** illustrates an example embodiment of a second ball **18** placed within a second ball station **22**. Each ball charging station **22** can include one or more concave surface **30** configured to receive a first ball **16** and/or a second ball **18**. Each ball charging station **22** can further include a wireless battery charger **31** and/or a transceiver **32**. In use, the wireless battery charger **31** is configured to provide wireless power to a respective battery of first ball **16** and/or a second ball **18**, for example, via electromagnetic inductive or non-radiative charging, loosely-coupled or radiative electromagnetic resonant charging, uncoupled radio frequency wireless charging, and/or other types of wireless charging. The transceiver **32** is configured to communicate with and/or detect one or more elements of a first ball **16** and/or a second ball **18**. In an embodiment, the wireless battery charger **31** and/or the transceiver **32** are placed in electronic communication with the control unit **24** via wiring **29** or wirelessly.

In an embodiment, the first ball **16** and the second ball **18** are formed with different materials to reflect their respective functions within the system **10**. The first ball **16** is intended to be hit by the golfer into the wall portion **14** using a driver or iron, and can thus be formed to be much softer and lighter than a real golf ball. This way, when the golfer takes a hard swing, the first ball does not damage the system **10** or anything else in the room. The second ball **18** is intended to be physically chipped or putted by the golfer using a wedge or putter, and should thus be formed to have the look and feel of a real golf ball since there should be little risk of powerful wayward shots. It should be understood from this disclosure, however, that certain embodiments can use both a first ball **16** and a second ball **18** which both have the look and feel of a real golf ball, while other certain embodiments can use

both a first ball **16** and a second ball **18** which are softer and/or lighter than a real golf ball. It should further be understood from this disclosure that, in some embodiments, a single ball can be used as both the first ball **16** and the second ball **18**. In yet another embodiment, a real golf ball can be used as the second ball **18** in accordance with the methods discussed herein.

In the illustrated embodiment of FIG. **9A**, the first ball **16** includes a cover layer **16a** and a core **16b**. The cover layer **16a** can include a soft material that will not damage either the wall unit **14** and/or another surface within the room upon contact. The soft material can be, for example, a foam or rubber material. The core **16b** can include a firmer material that protects the components therein. The firmer material can be, for example, a solid rubber material having a different weight and/or density than the soft material used to form the cover layer **16a**. Those of ordinary skill in the art will recognize from this disclosure that a first ball **16** can include other layers as well. In a simpler embodiment, the first ball **16** does not require multiple layers and can be formed of a single material.

In an embodiment, within the core **16b**, the first ball **16** further includes at least one sensor **40**, a light **41**, a transceiver **42**, and/or a battery **43**. The at least one sensor **40** can include a spin sensor **40s**, a first proximity sensor **40b**, a first speed sensor **40d**, and/or another sensor **40x**. The spin sensor **40s** can be configured to measure a spin rate of the first ball **16** during use of the system **10**. In an embodiment, the spin sensor **40s** includes a gyroscope. The first proximity sensor **40p** can be configured to emit a signal which can be detected by a corresponding transceiver **32**, **55**, **67**, **77**, **82** as described in more detail below. The first speed sensor **40d** can be configured to measure the speed and/or acceleration of the first ball **16**. In an embodiment, the first speed sensor **40d** includes an accelerometer. In various embodiments, more, less, or no sensors **40** can be used.

In an embodiment, the battery **43** is configured to receive and store the power needed to activate the at least one sensor **40**, the light **41**, and/or the transceiver **42**. The battery **43** can wirelessly receive power from the battery charger **31**, for example, via electromagnetic inductive or non-radiative charging, loosely-coupled or radiative electromagnetic resonant charging, uncoupled radio frequency wireless charging, and/or other types of wireless charging. That power can in turn power the transceiver **42** so that the transceiver **42** can send or receive wireless signals with various corresponding transceivers **32**, **55**, **67**, **77**, **82** of the system **10** and/or directly with the control unit **24**. In an embodiment, the transceiver **42** sends wireless signals regarding data generated by one or more sensor **40**. In an embodiment, the transceiver **42** receives wireless signals which cause the light **41** (e.g., an LED) to become illuminated.

In an embodiment, the second ball **18** is configured to look and feel more like a real golf ball in comparison to the first ball **16**. This is because the second ball **18** is utilized for chipping and putting and does not strike the wall unit **14** as does the first ball **16**. In the illustrated embodiment of FIG. **9B**, the second ball **18** includes a cover layer **18a**, an intermediate layer **18b**, and a core **18c**. The cover layer **18a** can replicate the outer layer of a real golf ball, for example, with a dimpled surface and formed of a hard resin such as urethane. The intermediate layer **18b** can include, for example, a rubber or elastic material wrapped around the core **18c**. The core **18c** can be made, for example, of a synthetic rubber or plastic material. Those of ordinary skill in the art will recognize from this disclosure that a second ball **18** can include other layers as well. In a simpler

embodiment, the second ball **18** does not require multiple layers and can be formed of a single material. Any of the features of the first ball **16** can be included in the second ball **18**, and vice versa.

In an embodiment, within the core **18c**, the second ball **18** further includes at least one sensor **46**, a light **47**, a transceiver **48**, and a battery **49**. The at least one sensor **46** can include a spin sensor **46s**, a second proximity sensor **46p**, a second speed sensor **46d**, and/or another sensor **46x**. The spin sensor **46s** can be configured to measure a spin rate of the second ball **18** during use of the system **10**. In an embodiment, the spin sensor **46s** includes a gyroscope. The second proximity sensor **46p** can be configured to emit a signal which can be detected by a corresponding transceiver **32**, **55**, **67**, **77**, **82** as described in more detail below. The second speed sensor **46d** can be configured to measure the speed and/or acceleration of the second ball **18** and can be used to provide feedback to the golfer regarding the golfer's shots taken with the second ball **18**. In an embodiment, the second speed sensor **46d** includes an accelerometer. In various embodiments, more, less, or no sensors **46** can be used. In an embodiment, a real golf ball can be used as the second ball **18**.

In an embodiment, the battery **49** is configured to receive and store the power needed to activate the at least one sensor **46**, the light **47**, and/or the transceiver **48**. The battery **49** can wirelessly receive power from the battery charger **31**, for example, via electromagnetic inductive or non-radiative charging, loosely-coupled or radiative electromagnetic resonant charging, uncoupled radio frequency wireless charging, and/or other types of wireless charging. That power can in turn power the transceiver **48** so that the transceiver **48** can send or receive wireless signals with various corresponding transceivers **32**, **55**, **67**, **77**, **82** of the system **10** and/or directly with the control unit **24**. In an embodiment, the transceiver **48** sends wireless signals regarding data generated by one or more sensor **46**. In an embodiment, the transceiver **48** receives wireless signals which cause the light **47** (e.g., an LED) to become illuminated.

In an embodiment, the hitting portion **12b** of the floor unit **12** includes one or more hitting surface **50**, while the putting portion **12c** of the floor unit **12** can include a putting green surface **51**. During a golf hole, a golfer can hit a first ball **16** from one or more hitting surface **50** in the direction **D1** towards the wall unit **14** at least once, and the golfer can hit a second ball **18** from one or more hitting surface **50** in the direction **D2** towards the putting green surface **51** at least once. The golfer can also hit a first ball **16** from one or more hitting surface **50** in the direction **D1** towards the wall unit **14** at least once, and then put on the putting green surface **51** using a second ball **18** at least once.

In an embodiment, the one or more hitting surface **50** includes a plurality of hitting surfaces **50**. In the illustrated embodiment, the one or more hitting surface **50** includes a first surface **50a**, a second surface **50b**, and a third surface **50c**. As used herein, the first surface **50a** is also referred to as the fairway surface **50a**, the second surface **50b** is also referred to as the rough surface **50b**, and the third surface **50c** is also referred to as the sand surface **50c**. The purpose of these hitting surfaces **50** is to simulate the fairway, rough, and sand surfaces that a golfer would most frequently encounter on a real golf course. Additional or different hitting surfaces **50** can also be used. Use of these hitting surfaces **50** is discussed in more detail below.

In an embodiment, each hitting surface **50** includes at least one layer. In the illustrated embodiment, each hitting surface **50** includes a surface layer **52** and a support layer **53**,

which are positioned above an electrical layer **54** which can include wiring which electrically connects any electrical component of the hitting portion **12b** to the control center **20**. In the illustrated embodiment, for example, one or more transceiver **55** is located within each hitting zone **50**. The transceivers **55** can electrically communicate with the control unit **24** via wiring **29** or wirelessly.

In an embodiment, the fairway surface **50a** includes a surface layer **52a** and a support layer **53a**. The surface layer **52a** can include a thin surface which replicates the texture of a real fairway on a golf course. For example, the surface layer **52a** can be formed with an artificial grass having a length of about 0.3 to 0.5 inches. In an embodiment, the surface layer **52a** can include natural grass. The support layer **53a** can include a thicker surface which replicates the firmness of a real fairway on a golf course. For example, the support layer **53a** can include a foam, rubber or plastic material which replicates the firmness of the soil of a real fairway on a golf course. In a simpler embodiment, the fairway surface **50a** does not require multiple layers and can be formed of a single material.

In an embodiment, the rough surface **50b** includes a surface layer **52b** and a support layer **53b**. The surface layer **52b** can include a thin surface which replicates the texture of a real rough on a golf course. For example, the surface layer **52b** can be formed with an artificial grass having a length of about 1.0 to 1.3 inches. In an embodiment, the surface layer **52b** can include natural grass. The support layer **53b** can include a thicker surface which replicates the firmness of a real rough on a golf course. For example, the support layer **53b** can include a foam, rubber or plastic material which replicates the firmness of the soil of a real rough on a golf course. In a simpler embodiment, the rough surface **50b** does not require multiple layers and can be formed of a single material.

In an embodiment, the sand surface **50c** includes a surface layer **52c** and a support layer **53c**. The surface layer **52c** can include a thin surface which replicates the texture of a real sand trap on a golf course. The support layer **53c** can include a thicker surface which replicates the firmness of a real sand trap on a golf course. In an embodiment, the surface layer **52c** can include sand. In an embodiment, the support layer **53c** can include sand. In another embodiment, the support layer **53c** can include a foam, rubber or plastic material which replicates the firmness of the sand of a real sand trap on a golf course. In a simpler embodiment, the sand surface **50c** does not require multiple layers and can be formed of a single material.

In an embodiment, a fourth surface **50d** includes a surface layer **52d** and a support layer **53d** and/or a fifth surface **50e** includes a surface layer **52e** and a support layer **53e**. The fourth surface **50d** and/or the fifth surface **50e** can be used to replicate additional surfaces that a golfer might encounter on a typical golf course. Alternatively, the fourth surface **50d** and/or the fifth surface **50e** can be formed in the same way as the other surfaces **50** discussed herein. In an embodiment, the fourth surface **50d** and/or the fifth surface **50e** can be equipped with golf bag stands to hold the golf bags of one or more golfers using the system **10**. One advantage of the system **10** and/or method **100** discussed herein is that specialized golf clubs are not required and the golfer can use his or her own golf clubs to play a golf game. In an embodiment, however, specialized golf clubs can be configured to operate in conjunction with the system **10** and/or method **100**. The fourth surface **50d** and/or the fifth surface **50e** can further provide standing room for other golfers while a golfer is hitting a ball.

In an embodiment, each surface **50** includes at least one striking zone **56**. In the illustrated embodiment, each of the fairway surface **50a**, the rough surface **50b** and the sand surface **50c** includes a left striking zone **56L**, for a left-handed golfer and a right striking zone **56R** for a right-handed golfer. The left striking zone **56L** is located on the left side of its respective surface **50** from the perspective of FIG. 2, which enables a left-handed golfer to stand entirely within that respective surface **50** when hitting a first ball **16** towards the wall unit **14**. The right striking zone **56R** is located on the right side of its respective surface **50** from the perspective of FIG. 2, which enables a right-handed golfer to stand entirely within that respective surface **50** when hitting a first ball **16** towards the wall unit **14**. When hitting towards the putting green surface **51**, however, the “left” and “right” zones are switched.

In FIG. 2, only two striking zones **56** are shown within each of the first surface **50a**, the second surface **50b** and the third surface **50c**. It should be understood from this disclosure, however, that each zone can include more or less striking zones **56**. For example, striking zones can be located at different distances from the wall unit **14** and/or at different distances from the left and right sides of their respective surface **50**. In an embodiment, one or more surface **50** can include a grid of striking zones **56**, such that much or all of the surface area of the surface **50** includes a striking zone **56**.

As illustrated in FIG. 2, in an embodiment, the floor unit **12** includes a transceiver **55** located at each striking zone **56**. Each transceiver **55** can be configured to detect the presence of the first proximity sensor **40p** of the first ball **16** when the first ball **16** is placed within that respective striking zone **56**. Each transceiver **55** can also be configured to detect the presence of the second proximity sensor **46p** of the second ball **18** when the second ball **18** is placed within that respective striking zone **56**. Thus, the control unit **24** can determine when a first ball **16** or a second ball **18** has been placed within a striking zone **56**. Each transceiver **55** can also be configured to send and/or receive wireless signals with a first transceiver **42** of a first ball and/or a second transceiver **48** of a second ball **18**, e.g., to cause a light **41** or a light **47** to illuminate when a first ball **16** or second ball **18** is placed within a striking zone **56**.

In an embodiment, the putting portion **12c** of the floor unit **12** includes a plurality of putting green surface adjusters **60** located beneath the putting green surface **51**. In use, each of the putting green surface adjusters **60** can be independently controlled by the control unit **24** to be raised or lowered, thus adjusting the surface contour of the putting green surface **51**.

The putting green surface adjusters **60** can be formed in a variety of ways. An example embodiment of a putting green surface adjuster **60** is shown in more detail with reference to FIGS. 10 to 14 below. In the illustrated embodiment, the putting green surface adjuster **60** includes a base portion **61** and a surface supporting portion **62**. In use, the putting green surface **51** sits on top of the surface supporting portions **62** of a plurality of putting green surface adjusters **60**, and the control unit **24** adjusts the height of the base portion **61** of each putting green surface adjuster **60** to adjust the surface contour of the putting green surface **51**.

In an embodiment, the base portion **61** includes a bottom part **63** and a top part **64**. The bottom part **63** can be or include an actuator **65** that raises or lowers the top part **64**. In an embodiment, the bottom part **63** can include an actuator **65** which raises or lowers the top part **64** by rotating the top part **64** around the vertical center axis thereof. In an embodiment, the top part **64** includes a threaded outer surface which causes it to be raised or lowered when rotating

11

within the bottom part 63. In another embodiment, the bottom part 63 can include an actuator 65 which translates the top part 64 upward or downward without rotating the top part 64. The actuator 65 can be, for example, a linear actuator.

In the illustrated embodiment, the top part 64 includes a light 66 and/or a transceiver 67, which are discussed in more detail below. The light 66, the transceiver 67, and/or the actuator 65 can be placed in electrical communication with an electrical contact 68, which enables the control unit 24 to independently provide power to and/or control each component. Alternatively, the control unit 24 can wirelessly control these components.

As illustrated in FIGS. 4, 5, 13 and 14, in an embodiment, each base portion 61 is configured to be positioned within a corresponding aperture 70 in the electrical layer 53. Each aperture 70 can include an electrical contact 71 which is placed in communication with an electrical contact 68, thus placing the components of that putting green surface adjuster 60 in electrical communication with the control unit 24, e.g., via wiring 29 through electrical later 54 or wirelessly. By forming the electrical layer 53 and/or putting green surface adjuster 60 in this way, a malfunctioning putting green surface adjuster 60 can be quickly and easily replaced by simply removing it and inserting a new putting green surface adjuster 60 in its place. In this way, the control unit 24 can control the location of the putting green surface adjuster 60 as opposed to the putting green surface adjuster 60 itself, this allowing putting green surface adjusters 60 to be moved and/or replaced.

In an embodiment, the surface supporting portion 62 includes an aperture 72 in a center thereof, wherein the surface supporting portion 62 surrounding the aperture 72 forms a ball joint with a bulbous portion 73 of the base portion 61. In this way, the surface supporting portion 62 can rotate and/or tilt freely with respect to the base portion 61. This enables the surface supporting portion 62 to remain rotationally stationary as it is raised or lowered while the top part 64 rotates within the bottom part 63. This also enables the surface supporting portion 62 to support the putting green surface at various angles, such that a plurality of putting green surface adjusters 60 can drastically alter the contour of the putting green surface 51 in the x, y and z directions. In this way, the tilt of the surface supporting portion 62 adjusts to match the relative positioning of surrounding surface supporting portions 62, thus giving the putting green surface 51 a smooth feel even when different putting green surface adjusters 60 are located at different heights. The aperture 72 can further enable the light 66 to shine therethrough. The surface supporting portion 62 can further include a flat upper surface 74 to support the putting green surface 51.

In an embodiment, the putting green surface 51 is configured to replicate the surface of a putting green on a real golf course. In an embodiment, the top of the putting green surface 51 can be formed with an artificial grass having a length of about 0.10 to 0.15 inches. The putting green surface 51 can include a thin, flexible material which is capable of deforming based on the positioning of the putting green surface adjusters 60 located underneath. For example, the putting green surface 51 can be formed of rubber or flexible plastic. In an embodiment, the putting green surface 51 can be at least partially transparent so that the lights 66 below are visible to a golfer standing above. As illustrated in FIGS. 4 and 5, in an embodiment, the bottom of the putting green surface 51 can include a plurality of apertures 75, each of

12

which is sized, shaped and positioned to receive a respective surface supporting portion 62 of a putting green surface adjuster 60.

In an embodiment, the putting portion 12c of the floor unit 12 further includes a putting hole 76 within the putting green surface 51. The putting hole 76 can extend through the putting green surface 51 and between putting green surface adjusters 60 as shown in FIGS. 4 and 5. The putting hole 76 can further include a transceiver 77 which is configured to detect the presence of a second ball 18 when the second ball 18 is chipped or putted into the putting hole 76. In an embodiment, the putting hole 76 is a movable part which can be moved to different locations of the putting green surface 51 for different final hole H placements for different golf holes GH. In an embodiment, the putting hole 76 is configured to be placed in an aperture 70 (e.g., with the transceiver placed in electrical communication with an electrical contact 71) such that the putting hole 76 can be swapped with a putting green surface adjuster 60, or vice versa, at any location including an aperture 70.

In an embodiment, the wall unit 14 includes a display portion 14a and a sensor portion 14b. The display portion 14a can include a display screen 80 configured to display the image I projected by the image projector 21. The display screen 80 can include, for example, a white fabric material configured to display the image I projected by the image projector 21.

In an embodiment, the sensor portion 14b includes one or more wall sensor 81. The one or more wall sensor 81 can include one or more wall proximity sensor 81p configured to detect the location (vertical and/or horizontal in FIG. 3) where a first ball 16 strikes the display portion 14a. The one or more sensor 81 can include one or more impact sensor 81i configured to measure the magnitude of impact of a first ball 16 striking the display portion 14a. The one or more sensor 81 can further include or be connected to a transceiver 82 configured to wirelessly send and/or receive signals from a first ball 16 and/or the control unit 24. In an embodiment, a plurality of sensors 81 can form a grid along the length and width of the sensor portion from the perspective of FIG. 3.

In an embodiment, the sensor portion 12b further includes a data transmission device 84 which wirelessly communicates with the control unit 24. More specifically, the data transmission device 84 can wirelessly transmit data from one or more sensor 81 to the control unit 24 for further processing by the control unit 24. Each of the sensors 81 and/or transceivers 82 can electrically connect to the data transmission device 84, for example, via wiring 29.

FIGS. 15 and 16 illustrate an example embodiment of a method 100 for simulating a golf game in accordance with the present disclosure. It should be understood that the control unit 24 can be programmed to perform many of the steps of method 100 by causing the processor 25 to execute instructions stored on the memory 26. It should further be understood the many of the steps can be omitted or reordered without departing from the spirit and scope of method 100.

At step 110, a golfer can calibrate the system 10 for a new game. In calibrating the system 10, the control unit 24 sets weights to be used when the golfer strikes the first ball 16 into the wall unit 14. The weights are then used to calculate the flight/distance of the golfer's shot taken with the first ball 16. The weights can be ball weights or course weights. The ball weights are applied to recorded data specific to the first ball 16 when struck by the golfer, while the course weights are applied to condition data generated for a simulated golf hole GH being played by the golfer. For example, FIG. 17 illustrates an example embodiment of the display of a user

13

interface **23** during calibration, which is configured to allow a golfer to select his or her weights by sliding respective indicators up or down. In the example of FIG. 17, the power weight, the curve weight and the spin weight are ball weights, while the wind weight is a course weight. Those of ordinary skill in the art will further recognize from this disclosure that these are examples only and that different or additional weights can also be used.

In a simple embodiment, the golfer can choose to use standard weights which have been predetermined by the system **10**. The standard weights can be intended to simulate the true flight path and distance of a golfer's shot taken with a first ball **16**. Thus, the standard weights can be used to simulate the most realistic golf game using the system **10**.

In an embodiment, the golfer can set a weight for the power of his or her shots. The power weight increases or decreases the simulated length of each shot that is taken using a first ball **16**. The golfer may want to increase shot power, for example, if he or she does not have a strong swing and wishes to increase the distance that simulated shots travel. The golfer may want to decrease his or her shot power, for example, if playing against another golfer with a weaker shot, thus leveling the playing field.

In an embodiment, the golfer can set a weight to regulate the hook and/or slice of a shot (hereinafter the "curve weight"). The curve weight increases or decreases the distance that a shot taken using a first ball **16** might fade to the left or right after being hit by the golfer (e.g., regulate the hook and/or slice of each shot). The golfer may want to increase his or her hook/slice, for example, to make a golf game more challenging. The golfer may want to decrease their hook/slice, for example, if their shots tend to hook or slice more than they prefer.

In an embodiment, the golfer can set a weight for the spin of their shots. The spin weight increases or decreases the amount of ball spin of each shot that is taken using a first ball **16**. The golfer may want to increase the spin, for example, if they have a difficult time spinning a golf ball as much as they prefer. The golfer may want to decrease their spin, for example, if they tend to spin a golf ball more than they intend.

In an embodiment, the golfer can set a weight for wind. The wind weight increases or decreases the effect of simulated wind on each shot taken with a first ball **16**. The golfer may want to increase the wind, for example, to make a golf game played with system **10** more challenging. The golfer may want to decrease the wind, for example, to make a golf game played with system **10** less challenging.

In another embodiment, the golfer can choose between different game settings, for example, "Easy," "Medium," or "Hard," and the system **10** can set some or all of the weights based on the golfer's selection. Further, if multiple golfers are playing a competition using the system **10**, then each golfer can have different weights applied to their shots. For example, a first golfer can choose an "Easy" difficulty and have one set of weights applied to their shots, while a second golfer can choose a "Hard" difficulty and have another set of weights applied to their shots. In this way, the system **10** can handicap the golfers so that golfers of different skill sets can play a competitive game using the system **10**.

In an embodiment, the system **10** is configured to perform an autocalibration for a plurality of golfers to handicap the golfers, thus evening the playing field. In this embodiment, each golfer can take one or more shots into the wall unit **14** using a first ball **16**. The shots can be taken from one or more of the hitting surfaces **50** into the wall unit. The system **10** can thereafter compare various factors of the golfer's shots

14

such as power, spin and accuracy, and can apply weights for each of the golfers based on the comparison. For example, if a first golfer tends to hit the first ball about 10% harder than a second golfer (e.g., on average), then the system **10** can set the second golfer's power weight to be 10% higher than the first golfer. The same calculations can be made for other weights being applied by the system (e.g., using spin and/or accuracy).

In an embodiment, the system **10** is configured to be calibrated to provide club recommendations to a golfer playing a golf game. The calibration can be performed before the golf game or can be a continuous calibration performed while the golfer is playing the golf game. To calibrate for club recommendations, the control unit **24** can record data from shots taken by the golfer using different golf clubs. For example, for each club the golfer physically uses, the control unit **24** can calculate the average distance that the club causes a virtual ball to travel across the virtual golf hole GH. Then, before a golfer takes a shot during the golf game, the system **10** can provide a club recommendation by comparing those average distances to the distance between the current location L and the final hole H.

At step **120**, one or more golfer can set up a golf game using system **10**. More specifically, the golfer can set up a golf game using the control unit **24**. In setting up the golf game, the golfer can select, for example, the golf course which will be simulated and the number of holes. The system **10** enables real golf courses to be simulated, such that real golf holes are recreated as virtual golf holes GH. Alternatively, the golfer can generate a random golf course to play.

In an embodiment, the golfer can further set up various factors such as weather or course conditions, e.g., high or low winds, fast or slow fairway, wet or dry surfaces, etc., which can affect how the path of each shot taken using a first ball **16** is calculated. Alternatively, the golfer can randomize the weather or course conditions. The weather and course conditions determined at this step can be used by the control unit **24** to adjust the course weights.

At step **130**, the system loads a new golf hole GH to be played by one or more golfers. If the golfer is just beginning a golf game, then the new golf hole GH is the first golf hole GH. Otherwise, the new golf hole GH is a next golf hole GH (e.g., a second golf hole GH, a third golf hole GH, etc.).

In an embodiment, when the new golf hole GH is loaded, the control unit **24** causes the image projector **21** to display an image I of the new golf hole GH on the wall unit **14**, for example, as shown in FIGS. 1 and 2. The image I is taken from the perspective of where the golfer is hitting from. For example, if the golfer is taking a tee shot, then the image is of the golf hole GH from the perspective of the tee box B. The image I can further include various other information, for example, the number of golfers, their current scores, the wind speed and wind direction of the simulated hole, and/or the distance of the golfer's current position to the final hole H. That is, when the control unit **24** loads the new golf hole GH, the control unit **24** also loads course data CD related to the conditions for the golf hole GH (e.g., wind speed, surface speed, etc.).

In an embodiment, the image I of the new golf hole GH is displayed on a headset **200**, as discussed in more detail below. The headset **200** is configured to provide the golfer with a 360-degree view of the virtual golf hole GH from the perspective of where the golfer's ball is located. Thus, for example, at step **130**, the headset **200** is configured to provide the golfer with a 360-degree view of the virtual golf

15

hole GH from the perspective of the tee box R where the golfer will hit the first shot from.

At step 140, the golfer takes his or her first shot. The first shot is typically the tee shot. To take the first shot, the golfer first places a first ball 16 in a striking zone 56. In an embodiment, the first ball 16 can be placed on a tee for the tee shot, which can be built into the striking zone 56. When the first ball 16 is placed in a striking zone 56, the transceiver 32 for that striking zone 56 can detect the presence of the first proximity sensor 40p of the first ball 16 and determine that the first ball 16 has been placed in that striking zone 56. The transceiver 32 can further send a signal to the transceiver 42 of the first ball 16 to trigger the light 41, indicating to the golfer that the first ball 16 has been placed in the correct striking zone 56.

In an embodiment, the golfer chooses the striking zone 56 from which the golfer wishes to take the first shot with the first ball 16. When the first ball 16 is placed in the golfer's chosen striking zone 56, the transceiver 32 for that striking zone 56 can detect the presence of the first proximity sensor 40p of the first ball 16 and notify the control unit 24. The positioning of the first ball 16 can then be used by the control unit 24 when calculating the flight path and/or distance of the first ball 16.

In an embodiment, the control unit 24 shifts the image I based on the striking zone 56 in which the golfer places the first ball. For example, as shown in FIGS. 18A and 18B, the center C of the image I can be shifted to be directly in front of the striking zone 56 which the golfer will hit from. In FIG. 18A, the golfer is hitting from a left striking zone 56L within the first hitting surface 50a, and the center C of the image I is shifted leftward accordingly. Likewise, in FIG. 18B, the golfer is hitting from a right striking zone 56R of the first hitting surface 50a, and the center C of the image I is shifted rightward accordingly.

The golfer can then choose a golf club for the tee shot. With the presently disclosed system, the golfer is able to play with his or her own set of golf clubs. In an alternative embodiment, the system 10 can be configured for use with specialized golf clubs having their own sensors which affect the calculation of ball flight and/or distance.

The golfer can then hit the first ball 16 into the wall unit 14. More specifically, the golfer can hit the first ball 16 from the striking zone 56 of the first hitting surface 50a into the display screen 80 of the wall unit 14. Upon the first ball striking the wall unit, the control unit 24 can collect ball data BD and unit data UD, as described in more detail below.

At step 150, the control unit 24 is configured to determine the ball placement for the next shot. More specifically, the control unit 24 can determine the landing spot of the golfer's shot in relation to the virtual golf hole GH. The control unit 24 can determine the landing spot, for example, by calculating the flight path of the shot using the ball data BD, unit data US, and/or course data CD. The control unit 24 can further cause the image projector 21 to display the flight path within the image I so that the golfer can watch the ball fly across the virtual golf hole GH.

As illustrated in more detail by FIG. 16, in an embodiment, the control unit 24 begins by collecting ball data BD at step 151 and/or unit data UD at step 152. The ball data BD is data recorded by one or more sensor 50 of the first ball 16, for example, ball speed data and/or ball spin data. The unit data UD is data recorded by the floor unit 12 and/or wall unit 14, for example, positioning data related to the striking zone 56 from which the golfer hit, location data recorded by a sensor 81 of the wall unit regarding the X and Y coordinates of where the first ball 16 struck the wall unit 14, and/or

16

impact data regarding the power of the impact when the first ball 16 struck the wall unit 14.

At step 153, the control unit 24 combines the ball data BD and/or the unit data UD with the course data CD loaded at step 130. In various embodiments, one or more of these types of data can be omitted.

At step 154, the control unit 24 determines the landing location L of the current shot. The control unit 24 can determine the landing location IL by calculating the flight path of the ball on the virtual golf hole GH. The control unit 24 can calculate the flight path, for example, by determining the flight distance, flight angles, and/or curve of the shot taken with the first ball 16.

In an embodiment, the flight distance is based on the power of the shot taken with the first ball 16. The power of the shot can be indicated by ball data BD generated by a speed sensor 40d of the first ball 16 and/or by unit data UD generated by an impact sensor 81i of the wall unit 14. The flight distance can further be affected by course data CD regarding wind speed, wind direction, surface speed, etc. Here, corresponding power weights can further be applied to lengthen or shorten the flight distance.

In an embodiment, the flight angle is based on the vertical and horizontal angles of the shot taken with the first ball 16 with respect to the striking zone 56. These angles can be determined, for example, based on unit data UD regarding the location where the first ball 16 strikes the wall unit 14 as detected by a proximity sensor 80p and/or an impact sensor 80i of the wall unit 14. Knowing the striking zone 56 from which the first ball was hit, along with the distance between the striking zone 56 and the wall unit 14, the control unit 24 can calculate the vertical and horizontal angles using simple geometric equations. Here, corresponding accuracy weights can further be applied to increase or decrease the flight angle.

In an embodiment, the curve of the shot indicates the hook or slice of the shot based on how the golfer hit the first ball 16. The curve of the shot can be indicated by ball data BD generated by a spin sensor 40d of the first ball 16. The curve of the shot can further be affected by course data CD regarding wind speed and wind direction. Here, corresponding spin weights can further be applied to increase or decrease the curve of the flight path.

In an embodiment, the control unit 24 is configured to calculate the simulated flight path of the ball on the virtual golf hole GH using the flight distance, flight angles, and/or the curve of the shot taken with the first ball 16. The control unit can further use course data such as the surface speed and weather conditions (e.g., wet or dry) to further influence the flight path and/or determine how the ball rolls after hitting the ground on the virtual golf hole GH. Based on this calculation, the control unit 24 can determine the landing location L which marks the final resting place of the ball on the virtual golf hole GH.

At step 155, the control unit determines the distance d between the landing location L and the final hole H. If the distance d is greater than the predetermined radius PR used to mark the area AR for that golf hole GH, and thus the landing location L is not within the area AR, then the method 100 proceeds step 160 and the golfer again uses a first ball 16 for the next shot. The golfer's next shot will again be from a hitting surface 50 in the direction D1. If the distance d is less than the predetermined radius PR used to mark the area AR for that golf hole GH, and thus the landing location L is within the area AR, then the method 100 proceeds to step 180 and the golfer switches to a second ball 18. The system 10, for example using the image projector 21 and/or

17

the headset **200**, can inform the golfer which ball to use for the next shot and/or where the next shot will take place from.

At step **160**, the golfer is again hitting a first ball **16** into the wall unit **14**. Based on where the golfer's previous landing location **L**, the control unit **24** can instruct the golfer where to place the first ball **16** for the next shot. More specifically, the control unit **24** can instruct the golfer which hitting surface **50** to place the ball on and/or where on the hitting surface **50** to place the first ball **16**.

As illustrated in more detail by FIG. **16**, in an embodiment, the control unit **24** begins prompting the next shot by determining the course data **CD** related to the current position at step **161**. For example, the simulated wind direction may have changed based on the landing location **L**.

At step **162**, the control unit **24** is configured to instruct the golfer where to place the first ball **16** to take the next shot. For example, if the golfer's previous simulated shot landed in the fairway **F** of the golf hole **GH**, then the control unit **24** can instruct the golfer to place the first ball **16** on the fairway hitting surface **50a**. Likewise, if the golfer's previous simulated shot landed in the rough **R** of the golf hole **GH**, then the control unit **24** can instruct the golfer to place the first ball **16** on the rough hitting surface **50b**. Likewise, if the golfer's previous simulated shot landed in a sand trap **S** of the golf hole **GH**, then the control unit **24** can instruct the golfer to place the first ball **16** on the sand hitting surface **50c**.

In an embodiment, the control unit **24** is configured to instruct the golfer as the precise striking zone **56** to place the first ball **16**. When the first ball **16** is placed in the striking zone **56**, the transceiver **32** for that striking zone **56** can detect the presence of the first proximity sensor **40p** of the first ball **16** and determine that the first ball **16** has been placed in the correct or incorrect striking zone **56**. If the first ball **16** has been placed in the correct striking zone **56**, the transceiver **32** can further send a signal to the transceiver **42** of the first ball **16** to trigger the light **41**, indicating to the golfer that the first ball **16** has been placed in the correct striking zone **56**.

In another embodiment, the golfer can choose the striking zone **56** from which the golfer wishes to take the next shot with the first ball **16**, as long as the golfer is hitting from the correct hitting surface **50**. When the first ball **16** is placed in the golfer's chosen striking zone **56**, the transceiver **32** for that striking zone **56** can detect the presence of the first proximity sensor **40p** of the first ball **16** and notify the control unit **24**. The positioning of the first ball **16** can then be used by the control unit **24** when calculating the flight path of the first ball **16**.

At step **163**, the control unit **24** causes the image projector **21** to display a new image **I**. The new image **I** can be a three-dimensional image of the remaining portion of the golf hole **GH** from the perspective of the golfer at the landing location **L**, e.g., from where the golfer's ball is located on the golf hole **GH**. The control unit **24** can further adjust the center **C** of the image to reflect the position that the first ball **16** is being hit from.

In an embodiment, the image **I** of the golf hole **GH** is displayed on a headset **200**, as discussed in more detail below. More specifically, the headset **200** is configured to provide the golfer with a 360-degree view of the virtual golf hole **GH** from the perspective of the landing location **L**, e.g., from where the golfer's ball is located on the golf hole **GH**. Thus, the golfer can examine the golf course from where he or she will hit the next shot.

At step **170**, the golfer again hits the first ball **16** into the wall unit **14**. The method **100** then returns to step **150** so that

18

the control unit **24** can calculate the ball's next flight path as discussed above. Steps **150**, **160** and **170** can be repeated until the control unit **24** simulates the golfer's shot landing within a distance **d** of the final hole **H** that is less than the predetermined radius **PR** used to mark the area **AR** for that golf hole **GH**, and thus the landing location **L** is within the area **AR**.

At step **180**, the golfer's previous shot has landed within the distance **d** of the final hole **H** that is less than the predetermined radius **PR**. The system **10** determines the type of surface **50** of the landing location **L**. Based on this information, the system **10** adjusts the putting green surface **62** and instructs the golfer where on the floor unit **12** to place a second ball **18** for the final shot(s) of the current golf hole **GH**. FIG. **19** illustrates an example embodiment showing how a landing location can be located on a fairway **F**, rough **R**, sand trap **S** and/or putting green **G** and be within the predetermined radius **PR** used to mark the area **AR** for that golf hole **GH**.

In an embodiment, if the golfer's previous simulated shot landed on the putting green **G**, then the system **10** instructs the golfer to place a second ball **18** on the putting green surface **51** to begin the final one or more shot of the current golf hole **GH**. If the golfer's previous simulated shot landed on the fairway, rough, a sand trap or another surface, then the system **10** instructs the golfer to place a second ball **18** on a corresponding hitting surface **50**. For example, if the golfer's previous simulated shot landed on the fairway **F**, then the system **10** instructs the golfer to place a second ball **18** on the fairway hitting surface **50a**; if the golfer's previous simulated shot landed in the rough **R**, then the system **10** instructs the golfer to place a second ball **18** on the rough hitting surface **50b**; if the golfer's previous simulated shot landed in a sand trap **S**, then the system **10** instructs the golfer to place a second ball **18** on the sand hitting surface **50c**.

FIG. **20A** illustrates a first example embodiment in which the golfer's landing location **L** is on a fairway **F** within the predetermined radius **PR**. The control unit **24** therefore selects a corresponding striking zone **56** within the fairway hitting surface **50a** which places the second ball **18** at the distance **d** from the putting hole **76**. The control unit **24** also rotates the surface contour **SC** so that the virtual line **L1** between the landing location **L** and the final hole **H** can be matched by the line **L2** between the physical line between the striking zone **56** and the putting hole **76**. The control unit **24** can then independently control each of the putting green surface adjusters **60** so that the contour of the putting green surface **51** accurately mimics the surface contour **SC** from the golfer's landing location **L** within the fairway **F**.

FIG. **20B** illustrates a second example embodiment in which the golfer's landing location **L** is on a rough **R** within the predetermined radius **PR**. The control unit **24** therefore selects a corresponding striking zone **56** within the rough hitting surface **50b** which places the second ball **18** at the distance **d** from the putting hole **76**. The control unit **24** also rotates the surface contour **SC** so that the virtual line **L1** between the landing location **L** and the final hole **H** can be matched by the line **L2** between the physical line between the striking zone **56** and the putting hole **76**. The control unit **24** can then independently control each of the putting green surface adjusters **60** so that the contour of the putting green surface **51** accurately mimics the surface contour **SC** from the golfer's landing location **L** within the rough **R**.

FIG. **20C** illustrates a third example embodiment in which the golfer's landing location **L** is on a sand trap **S** within the predetermined radius **PR**. The control unit **24** therefore

19

selects a corresponding striking zone **56** within the sand hitting surface **50c** which places the second ball **18** at the distance *d* from the putting hole **76**. The control unit **24** also rotates the surface contour **SC** so that the virtual line **L1** between the landing location **L** and the final hole **H** can be matched by the line **L2** between the physical line between the striking zone **56** and the putting hole **76**. The control unit **24** can then independently control each of the putting green surface adjusters **60** so that the contour of the putting green surface **51** accurately mimics the surface contour **SC** from the golfer's landing location **L** within the sand trap **S**.

FIG. **20D** illustrates a fourth example embodiment in which the golfer's landing location **L** is the putting green **G**. The control unit **24** therefore selects a location on the putting green surface **51** which places the second ball **18** at the distance *d* from the putting hole **76**. The control unit **24** also rotates the surface contour **SC** so that the virtual line **L1** between the landing location **L** and the final hole **H** can be matched by the line **L2** between the physical line between the putting location **83** and the putting hole **76**. The control unit **24** can then independently control each of the putting green surface adjusters **60** so that the contour of the putting green surface **51** accurately mimics the surface contour **SC** from the golfer's landing location **L** on the putting green **G**.

As illustrated in more detail by FIG. **16**, in an embodiment, the control unit **24** begins prompting the final shot(s) with the second ball **18** by determining the course data **CD** related to the current position at step **181**. The course data **D** can include the landing location **L** and the surface contour **SC** with respect to the landing location **L**.

At step **182**, the control unit **24** adjusts the putting green surface **51**. More specifically, the control unit **24** can rotate the surface contour **SC** as described above, so that the virtual line **L1** between the landing location **L** and the final hole **H** can be matched by the line **L2** between the physical line between the striking zone **56** and the putting hole **76**. The control unit can independently control each of the putting green surface adjusters **60** so that the contour of the putting green surface **51** accurately mimics the surface contour **SC** from the golfer's landing location **L**. More specifically, the control unit **24** can cause each surface supporting portions **62** of a putting green surface adjuster **60** to be raised or lowered based on the surface sections **SS1**, **SS2** . . . **SSn** which determine the surface contour **SC**.

At step **183**, the control unit **24** instructs the golfer where to place the second ball **18** to take the final shot(s). For example, if the golfer's previous shot landed in the fairway **F** of the golf hole **GH**, then the control unit **24** can instruct the golfer to place the first ball **16** on the fairway hitting surface **50a**; if the golfer's previous simulated shot landed in the rough **R** of the golf hole **GH**, then the control unit **24** can instruct the golfer to place the first ball **16** on the rough hitting surface **50b**; if the golfer's previous simulated shot landed in a sand trap **S** of the golf hole **GH**, then the control unit **24** can instruct the golfer to place the first ball **16** on the sand hitting surface **50c**; if the golfer's previous simulated shot landed on the putting green **G** of the golf hole **GH**, then the control unit **24** can instruct the golfer to place the first ball **16** on the putting surface **51**.

In an embodiment, the control unit **24** instructs the golfer as the precise striking zone **56** to place the second ball **16** and/or at the precise location on the putting green surface **51**. When the second ball **18** is placed in the correct striking zone **56**, the transceiver **32** for that striking zone **56** can detect the presence of the second proximity sensor **46p** of the second ball **18** and determine that the second ball **18** has been placed in the correct or incorrect striking zone **56**. If the

20

second ball **18** has been placed in the correct striking zone **56**, the transceiver **32** can further send a signal to the transceiver **48** of the second ball **18** to trigger the light **47**, indicating to the golfer that the second ball **18** has been placed in the correct striking zone **56**. Likewise, when the second ball **18** is placed on the putting green, the transceiver **67** of the putting green surface adjuster **60** located beneath the second ball can detect the presence of the second proximity sensor **46p** of the second ball **18** and determine whether the second ball **18** has been placed in the correct location on the putting green surface **51**. If the second ball **18** has been placed in the correct location on the putting green surface, the transceiver **67** can further send a signal to the transceiver **48** of the second ball **18** to trigger the light **47**, indicating to the golfer that the second ball **18** has been placed in the correct striking zone **56**.

At step **184**, the control unit **24** adjusts the image **I** on the display screen to reflect, for example a three-dimensional image of the golf hole **GH** from the perspective of the golfer. The control unit **24** can also adjust the image **I** to provide information regarding the distance to the hole, the surface contour **SC**, and/or other information which the golfer may appreciate.

In an embodiment, the image **I** of the golf hole **GH** is displayed on a headset **200**, as discussed in more detail below. More specifically, the headset **200** is configured to provide the golfer with a 360-degree view of the virtual golf hole **GH** from the perspective of where the ball is located on the putting green **G**. Thus, the golfer can look around the golf hole **GH** from where he or she will putt next. In an embodiment, the golfer can walk around and use the headset **200** to examine the golf hole **GH** from various locations and/or perspectives, thus enabling the golfer to carefully examine the putting green **G** and/or its surface contour **SC**. In an embodiment, the headset **200** can instruct the golfer where to place the second ball **18** for the next shot, for example, by displaying an image of the ball and/or location.

At step **190**, the golfer can hit the final shot(s) of the golf hole by hitting the second ball **18** into the putting hole **76**. A skilled golfer may only require one final shot; an amateur may require more. The golfer should be able to take the final shots using a wedge or putter without the putting green surface **51** again needing adjustment. In various embodiments, however, the putting green surface can continue to be further adjusted after a chip or putt.

In an embodiment, when the golfer finally hits the second ball **18** into the putting hole **76**, the transceiver **77** of the putting hole **76** detects the presence of a second ball **18** and determine the golfer's score for that golf hole **GH**. The system **10** can then return to step **130** and load a new golf hole **GH**.

In an embodiment, the system **10** includes a headset **200**. FIG. **21** illustrates an example embodiment of a headset **200** in accordance with the present disclosure. The headset **200** includes a frame **202**. In the illustrated embodiment, the frame **202** is formed in the shape of glasses which can be worn by a golfer while using one or more of the floor unit **12**, the wall unit **14**, the first ball **16**, and/or the second ball **18**. The frame **202** can also be formed in other shapes and sizes. The headset **200** can be used, for example, to enhance the virtual portion of a golf game played using the system **10** and/or method **100**. In an embodiment, the headset **200** displays an image **I** instead of or in addition to an image **I** displayed on the wall unit **14**.

In the illustrated embodiment, the headset **200** includes a processor **204** and a memory **206**. The processor **204** is configured to execute instructions stored on the memory **206**

21

to enable the headset **200** to function in conjunction with the methods discussed herein. The memory **206** can include a non-transitory, computer-readable medium. The processor **204** is further configured to execute instructions received from the control unit **24**. The headset **200** can therefore further include a data transmission device **208** configured to communicate with the control unit **24**, with other elements of the system **10** discussed herein, and/or with an online central server. The data transmission device **208** can include a data bus, a wireless transceiver, and/or any other data transmission mechanism. The data transmission device **208** can be configured for wired or wireless transmission. The data transmission device **208** can be configured for Bluetooth communication with the control unit **24**.

In an embodiment, the headset **200** includes at least one display screen **210**. Here, the headset **200** includes a left display screen **210L** and a right display screen **210R**. As illustrated, the display screens **210L**, **210R** correspond to the lenses of the glasses frame **202**. In the illustrated embodiment, the left display screen **210L** corresponds to the golfer's left eye, and the right display screen **210R** corresponds to the golfer's right eye. The display screen **210** can also be formed as a continuous display screen which includes both of the left display screen **210L**, and the right display screen **210R** instead of a separate left display screen **210L** and right display screen **210R**.

In an embodiment, the display screen **210** is at least partially transparent. The display screen **210** is also configured to display a plurality of images of a virtual golf hole GH. In an embodiment, the display screen **210** is configured to display one or more image I in accordance with the methods discussed herein. The images I are displayed on the inside of the display screen **210** for viewing by a golfer wearing the headset **200**. By using a system **10** including a headset **200**, a golfer can further enhance the experience of playing a virtual golf hole GH in accordance with the method **100** discussed herein.

In an embodiment, the headset **200** alternates between a first (e.g., transparent) mode and a second (e.g., virtual) mode. FIG. **22A** illustrates the headset **200** from the golfer's perspective while in the transparent mode, while FIG. **22B** illustrates the headset **22** from the golfer's perspective while in the virtual mode. In the transparent mode, the display screen **210** is at least partially transparent, for example, so that the golfer can see through the display screen **210** to view one or more of the floor unit **12**, the wall unit **14**, the first ball **16**, and/or the second ball **18**. In the virtual mode, the golfer is provided with a 360-degree view of the scenery of a virtual golf hole GH from one or more of a plurality of locations of the virtual golf hole GH. Thus, in the virtual mode, the display screen **210** is configured to display one or more image I in accordance with the methods discussed herein.

In an embodiment, the headset includes a motion sensor **212**. The processor **204** is configured to use the motion sensor **212** to determine the orientation and/or directional position of the headset **200**. In an embodiment, the motion sensor **212** includes a gyroscope, an accelerometer, and/or another type of sensor. The processor **204** is configured to use the motion sensor **212** to determine whether the golfer is looking downwardly (e.g., vertically, towards his or her feet) or outwardly (e.g., horizontally, towards the wall unit **14**). When the processor **204** detects that the golfer is looking downwardly, the processor **204** is configured to cause the headset **200** to be automatically placed in the first (e.g., transparent) mode. This enables the golfer to see the first ball **16** or the second ball **18** when swinging. When the

22

processor **204** detects that the golfer is looking outwardly, the processor **204** is configured to cause the headset **200** to be automatically placed in the second (e.g. virtual) mode. This enables the golfer to look around the virtual golf hole GH before and/or after hitting a shot. This also enables the golfer to watch his or her shot on the virtual golf hole GH after taking a swing. Thus, the headset **200** is configured to be in the transparent mode when the user strikes a first ball **16** and/or a second ball **18**, and then to automatically place itself in the virtual mode as the golfer follows through on his or her shot and watches the virtual golf ball travel across the virtual golf hole GH.

In the illustrated embodiment, the headset **200** includes a first button **214** and a second button **216**. The first button **214** can be used, for example, to manually alternate between the transparent mode and the virtual mode. The second button **216** can be used, for example, to adjust one or more image I displayed on the display screen **210** during the virtual mode (e.g., zoom in or out, cycle through course information, view the golf hole GH from different perspectives, etc.). It should be understood from this disclosure that the headset **200** can include additional buttons to perform additional functions as well.

In various embodiments, the headset can be used without a floor unit **12** and/or without a wall unit **14**. In an embodiment, the headset **200** can be programmed to perform one or more of the steps of method **100** by causing the processor **204** to execute instructions stored on the memory **206**. In an embodiment, the headset **200** can be programmed to perform one or more of the steps of method **100** by working in conjunction with the control unit **24**. In an embodiment, the control unit **24** can be a separate device from a floor unit **12**, allowing the method **100** to be performed without a floor unit **12**.

FIGS. **23A** and **23B** illustrate an example embodiment of a golfer using the headset **200** as part of the system **10**. In FIG. **23A**, the headset **200** is in the transparent mode as the golfer takes a swing. Here, the golfer is preparing to strike a first ball **16** into the wall unit **14**. In an embodiment, the headset **200** automatically places itself in the transparent mode as the golfer looks downwardly at the first ball **16**. Then, as the golfer looks up during the follow-through of the swing in FIG. **23B**, the headset **200** automatically places itself in the virtual mode so the golfer can watch the virtual ball travel across the virtual golf hole GH. The virtual ball can travel across the virtual golf hole GH in accordance with the flight path determined according to the methods discussed above.

In an embodiment, before the golfer takes a swing in FIG. **23A**, the headset **200** is configured to be in the transparent mode or the virtual mode. If the golfer is looking outwardly before taking a swing, then the headset **200** can automatically place itself in the virtual mode so the golfer can look around the virtual golf hole GH and examine the virtual surroundings (e.g., the fairway F, the rough R, the putting green G, the final hole H (e.g., including a flag pole), the sand trap S, the water hazard W, the tree hazard T, the tee box B, etc.). Alternatively, the golfer can use the first button **214** to place the headset in the virtual mode if the golfer wishes to look around and examine the virtual surroundings of the virtual golf hole GH. Then, when the golfer looks down to begin a swing, the headset **200** is configured to automatically place itself in the transparent mode so that the golfer can see the first ball **16** or the second ball **18** (e.g., whichever ball **16**, **18** that the golfer is using for the next shot). Alternatively, the golfer can use the first button **214** to

place the headset **200** in the transparent mode when the golfer wishes to focus on the first ball **16** or the second ball **18** and take a shot.

In an embodiment, after the golfer takes a shot, the headset **200** is configured to display one or more image **I** from the location **L** within the virtual golf hole **GH** where the last shot landed. Thus, after each shot, the headset **200** can provide the golfer with a 360-degree view of the scenery of the virtual golf hole **GH** from whatever location **L** the golfer's virtual golf ball has been calculated to land at within the virtual golf hole **GH**. In an embodiment, the golfer can walk around near the landing location **L**, and the headset will adjust the display screen **210** to reflect the surroundings of the virtual golf hole **GH** (e.g., adjust one or more image **I**). Thus, the headset enables the golfer to feel like he or she is walking around a real golf hole. Various methods for adjusting such a display screen **210** on the headset **200** are known in the virtual reality and/or augmented reality arts and can be used to implement the 360-degree view of the virtual golf hole **GH** in accordance with the methods discussed herein.

In an embodiment, the headset **200** is configured to alternate between a striking mode and a putting mode. In an embodiment, the headset **200** can be automatically placed in the striking mode or the putting mode based on instructions from the control unit **24** as to whether the golfer is putting or not putting. In an embodiment, the headset **200** is configured to automatically initiate the striking mode or the putting mode based on the type of ball that the golfer is using. For example, the headset **200** can automatically place itself in the striking mode when the golfer is using a first ball **16**. Likewise, the headset **200** can automatically place itself in the putting mode when the golfer is using a second ball **16**. In an embodiment, the first button **214** can be used to manually alternate between the striking mode and the putting mode.

In an embodiment, the striking mode operates as shown and discussed above with respect to FIGS. **23A** and **23B**. More specifically, when in the striking mode, the headset **200** can alternate between the transparent mode and the virtual mode as discussed above. Additionally or alternatively, when in the striking mode, the headset **200** can display information about the golfer's next shot. For example, the display screen **210** can display the calculated distance between the current location **L** and the final hole **H**, a club recommendation, the virtual wind speed, the virtual wind direction, and/or any other information about the golfer's next shot (e.g., information or numbers that will be used to calculate the golfer's next virtual shot).

In an embodiment, the putting mode differs from the striking mode in that the headset **200** does not automatically alternate between the transparent mode and the virtual mode based on the golfer's viewing direction when in the putting mode. Since the golfer is putting into a physical hole when the headset **200** is in the putting mode, the putting mode remains in the transparent mode as the golfer lifts his or her head so that the golfer can watch the physical put. In an embodiment, the golfer can use the first button **214** to alternate between the transparent mode and the virtual mode while in the putting mode. Thus, in an embodiment, the headset **200** automatically alternates between the transparent mode and the virtual mode when in the striking mode, but requires manual use of the first button **214** to alternate between the transparent mode and the virtual mode when in the putting mode. Alternatively, the headset **200** can also automatically alternate between the transparent mode and the virtual mode as described above when in the putting mode.

In an embodiment, the putting mode can also differ from the striking mode in that different types of information are displayed on the display screen **210** during the putting mode. For example, the display screen **210** can display information about the putting green **G**, the distance that must be physically putted by the golfer to the hole **76**, the contour of the putting green surface **51**, and/or any other information about the golfer's next shot. In an embodiment, the display screen **210** can display the putting green surface contour to the golfer, for example, by displaying a grid showing the rises and dips in the putting green surface **51** using virtual and/or augmented reality.

It is envisioned that the systems and methods described herein can also be applied to other sports besides golf. FIG. **24** illustrates an example embodiment of the systems and methods described herein applied to baseball. Other sports include, e.g., basketball, football (American or European style), volleyball, softball, dodgeball, handball, racquetball, paddleball, hockey, tennis, or others.

GENERAL INTERPRETATION OF THE TERMS

In understanding the scope of the present disclosure, the term "comprising" and its derivatives, as used herein, are intended to be open ended terms that specify the presence of the stated features, elements, components, groups, integers, and/or steps, but do not exclude the presence of other unstated features, elements, components, groups, integers and/or steps. The foregoing also applies to words having similar meanings such as the terms, "including", "having" and their derivatives. Also, the terms "part," "section," "portion," "member" or "element" when used in the singular can have the dual meaning of a single part or a plurality of parts.

The term "configured" as used herein to describe a component, section or part of a device includes hardware and/or software that is constructed and/or programmed to carry out the desired function.

The term "processor" as used herein can refer to one or more processors, such as one or more special purpose processors, one or more digital signal processors, one or more microprocessors, and/or one or more other processors as known in the art.

The term "memory" as used herein can refer to any computer useable or computer readable medium or device that can contain, store, communicate, or transport any signal or information that can be used with any processor. For example, a memory can include one or more read only memory (ROM), random access memory (RAM), one or more other memory, and/or combinations thereof.

While only selected embodiments have been chosen to illustrate the present disclosure, it will be apparent to those skilled in the art from this disclosure that various changes and modifications can be made herein without departing from the scope of the present disclosure. For example, the size, shape, location or orientation of the various components can be changed as needed and/or desired. Components that are shown directly connected or contacting each other can have intermediate structures disposed between them. The functions of one element can be performed by two, and vice versa. The structures and functions of one embodiment can be adopted in another embodiment. It is not necessary for all advantages to be present in a particular embodiment at the same time. Every feature which is unique from the prior art, alone or in combination with other features, also should be considered a separate description of further inventions by the applicant, including the structural and/or functional

concepts embodied by such feature(s). Thus, the foregoing descriptions of the embodiments according to the present invention are provided for illustration only, and not for the purpose of limiting the invention as defined by the appended claims and their equivalents.

ASPECTS OF THE DISCLOSURE

Aspects of the subject matter described herein may be useful alone or in combination with any one or more of other aspect described herein. Without limiting the foregoing description, in a first aspect of the present disclosure, a system for playing a golf game within limited confines includes a wall unit configured to display a virtual portion of the golf game, a floor unit configured to enable a physical portion of the golf game, and a control unit programmed to use first data related the virtual portion and second data related to the physical portion to enable a golfer to play a full golf hole.

In accordance with a second aspect of the present disclosure, which may be used in combination with any other aspect or combination of aspects listed herein, the first data includes course data.

In accordance with a third aspect of the present disclosure, which may be used in combination with any other aspect or combination of aspects listed herein, the second data includes ball data.

In accordance with a fourth aspect of the present disclosure, which may be used in combination with any other aspect or combination of aspects listed herein, the second data includes unit data.

In accordance with a fifth aspect of the present disclosure, which may be used in combination with any other aspect or combination of aspects listed herein, the system includes a first ball and a second ball, the first ball configured to be hit by the golfer from the floor unit into the wall unit, the second ball configured to be putted by the golfer on the floor unit.

In accordance with a sixth aspect of the present disclosure, which may be used in combination with any other aspect or combination of aspects listed herein, the first ball differs in weight and/or density in comparison to the second ball.

In accordance with a seventh aspect of the present disclosure, which may be used in combination with any other aspect or combination of aspects listed herein, the first ball is configured to be lighter and/or softer than a real golf ball, and the second ball is configured to have the look and feel of a real golf ball.

In accordance with an eighth aspect of the present disclosure, which may be used in combination with any other aspect or combination of aspects listed herein, at least one of the first ball or the second ball includes a proximity sensor which can be detected by one or more transceiver located in the floor unit or the wall unit.

In accordance with a ninth aspect of the present disclosure, which may be used in combination with any other aspect or combination of aspects listed herein, the first ball includes a spin sensor configured to measure a spin rate of the first ball when the first ball is hit by the golfer from the floor unit into the wall unit.

In accordance with a tenth aspect of the present disclosure, which may be used in combination with any other aspect or combination of aspects listed herein, the first ball includes a speed sensor configured to measure the speed and/or acceleration of the first ball when the first ball is hit by the golfer from the floor unit into the wall unit.

In accordance with an eleventh aspect of the present disclosure, which may be used in combination with any other aspect or combination of aspects listed herein, the second ball includes a speed sensor configured to measure the speed and/or acceleration of the second ball when the second ball is putted by the golfer on the floor unit.

In accordance with a twelfth aspect of the present disclosure, which may be used in combination with any other aspect or combination of aspects listed herein, at least one of the first ball or the second ball includes a light.

In accordance with a thirteenth aspect of the present disclosure, which may be used in combination with any other aspect or combination of aspects listed herein, at least one of the first ball or the second ball includes a transceiver.

In accordance with a fourteenth aspect of the present disclosure, which may be used in combination with any other aspect or combination of aspects listed herein, at least one of the first ball or the second ball includes a battery.

In accordance with a fifteenth aspect of the present disclosure, which may be used in combination with any other aspect or combination of aspects listed herein, the floor unit includes a plurality of different hitting surfaces.

In accordance with a sixteenth aspect of the present disclosure, which may be used in combination with any other aspect or combination of aspects listed herein, the plurality of different hitting surfaces includes at least two of: (i) a fairway hitting surface; (ii) a rough hitting surface; and (iii) a sand hitting surface.

In accordance with a seventeenth aspect of the present disclosure, which may be used in combination with any other aspect or combination of aspects listed herein, the full golf hole is from tee shot to final putt.

In accordance with an eighteenth aspect of the present disclosure, which may be used in combination with any other aspect or combination of aspects listed herein, the floor unit includes a putting green surface which enables the golfer to physically putt a final one or more shot of the golf hole.

In accordance with a nineteenth aspect of the present disclosure, which may be used in combination with any other aspect or combination of aspects listed herein, the floor unit includes a plurality of putting green surface adjusters configured to adjust the surface contour of the putting green surface.

In accordance with a twentieth aspect of the present disclosure, which may be used in combination with any other aspect or combination of aspects listed herein, the control unit controls the putting green surface adjusters based on a virtual landing location of the golfer's ball during the virtual portion of the golf game.

In accordance with a twenty-first aspect of the present disclosure, which may be used in combination with any other aspect or combination of aspects listed herein, the control unit is programmed to apply weights to second data.

In accordance with a twenty-second aspect of the present disclosure, which may be used in combination with any other aspect or combination of aspects listed herein, the control unit is programmed to determine the weights during a calibration process in which the user hits at least one ball from the floor unit into the wall unit.

In accordance with a twenty-third aspect of the present disclosure, which may be used in combination with any other aspect or combination of aspects listed herein, the control unit is programmed to calculate a flight path of a ball hit by the golfer from the floor unit into the wall unit.

In accordance with a twenty-third aspect of the present disclosure, which may be used in combination with any

other aspect or combination of aspects listed herein, the control unit is programmed to calculate a flight path of a ball hit by the golfer from the floor unit into the wall unit.

In accordance with a twenty-fourth aspect of the present disclosure, which may be used in combination with any other aspect or combination of aspects listed herein, the control unit is programmed to calculate the flight path of the ball using ball data from a sensor located within the ball.

In accordance with a twenty-fifth aspect of the present disclosure, which may be used in combination with any other aspect or combination of aspects listed herein, the control unit is programmed to calculate the flight path of the ball using unit data from a sensor located within the floor unit or the wall unit.

In accordance with a twenty-sixth aspect of the present disclosure, which may be used in combination with any other aspect or combination of aspects listed herein, the control unit is programmed to calculate the flight path of the ball using course data relating to a generated virtual golf hole.

In accordance with a twenty-seventh aspect of the present disclosure, which may be used in combination with any other aspect or combination of aspects listed herein, the control unit is programmed to calculate the flight path of the ball by calculating at least one of: (i) flight distance; (ii) flight angle; or (iii) curve.

In accordance with a twenty-eighth aspect of the present disclosure, which may be used in combination with any other aspect or combination of aspects listed herein, the control unit is programmed to instruct the golfer where to physically place the ball on the floor unit for a next shot based on the calculated flight path.

In accordance with a twenty-ninth aspect of the present disclosure, which may be used in combination with any other aspect or combination of aspects listed herein, the control unit is programmed to instruct the golfer which of a plurality of balls to use for a next shot based on the calculated flight path.

In accordance with a thirtieth aspect of the present disclosure, which may be used in combination with any other aspect or combination of aspects listed herein, the floor unit includes a putting green surface, and the control unit is programmed to adjust the putting green surface based on the calculated flight path.

In accordance with a thirty-first aspect of the present disclosure, which may be used in combination with any other aspect or combination of aspects listed herein, the control unit is programmed to adjust the putting green surface based on a ball landing location determined using the calculated flight path.

In accordance with a thirty-second aspect of the present disclosure, which may be used in combination with any other aspect or combination of aspects listed herein, the control unit is programmed to adjust a surface contour of the putting green surface.

In accordance with a thirty-third aspect of the present disclosure, which may be used in combination with any other aspect or combination of aspects listed herein, the control unit include a user interface.

In accordance with a thirty-fourth aspect of the present disclosure, which may be used in combination with any other aspect or combination of aspects listed herein, the user interface translated between an extended configuration in which the golfer can use the user interface, and a retracted configuration in which the golfer can play the golf game.

In accordance with a thirty-fifth aspect of the present disclosure, which may be used in combination with any

other aspect or combination of aspects listed herein, a system for playing a golf game within limited confine includes a wall unit configured to display a virtual portion of the golf game, a floor unit configured to enable a physical portion of the golf game, a first ball configured to be hit by the golfer from the floor unit into the wall unit, and a second ball configured to be putted by the golfer on the floor unit.

In accordance with a thirty-sixth aspect of the present disclosure, which may be used in combination with any other aspect or combination of aspects listed herein, the first ball differs in weight and/or density in comparison to the second ball.

In accordance with a thirty-seventh aspect of the present disclosure, which may be used in combination with any other aspect or combination of aspects listed herein, the first ball is configured to be lighter and/or softer than a real golf ball, and the second ball is configured to have the look and feel of a real golf ball.

In accordance with a thirty-eighth aspect of the present disclosure, which may be used in combination with any other aspect or combination of aspects listed herein, at least one of the first ball or the second ball includes a proximity sensor which can be detected by one or more transceiver located in the floor unit or the wall unit.

In accordance with a thirty-ninth aspect of the present disclosure, which may be used in combination with any other aspect or combination of aspects listed herein, the First ball includes a spin sensor configured to measure a spin rate of the first ball when the first ball is hit by the golfer from the floor unit into the wall unit.

In accordance with a fortieth aspect of the present disclosure, which may be used in combination with any other aspect or combination of aspects listed herein, the first ball includes a speed sensor configured to measure the speed and/or acceleration of the first ball when the first ball is hit by the golfer from the floor unit into the wall unit.

In accordance with a forty-first aspect of the present disclosure, which may be used in combination with any other aspect or combination of aspects listed herein, the second ball includes a speed sensor configured to measure the speed and/or acceleration of the second ball when the second ball is putted by the golfer on the floor unit.

In accordance with a forty-second aspect of the present disclosure, which may be used in combination with any other aspect or combination of aspects listed herein, at least one of the first ball or the second ball includes a light.

In accordance with a forty-third aspect of the present disclosure, which may be used in combination with any other aspect or combination of aspects listed herein, at least one of the first ball or the second ball includes a transceiver.

In accordance with a forty-fourth aspect of the present disclosure, which may be used in combination with any other aspect or combination of aspects listed herein, at least one of the first ball or the second ball includes a battery.

In accordance with a forty-fifth aspect of the present disclosure, which may be used in combination with any other aspect or combination of aspects listed herein, the system includes a control unit programmed to use first data related the virtual portion and second data related to the physical portion to enable a golfer to play a full golf hole.

In accordance with a forty-sixth aspect of the present disclosure, which may be used in combination with any other aspect or combination of aspects listed herein, the system includes a control unit programmed to calculate a flight path of a first ball hit by the golfer from the floor unit into the wall unit using ball data from a sensor located within the first ball.

In accordance with a forty-seventh aspect of the present disclosure, which may be used in combination with any other aspect or combination of aspects listed herein, a method for playing a golf game within limited confines includes generating a virtual golf hole, calculating a flight path of at least one ball physically hit by the golfer during a first shot related to the virtual golf hole, and instructing the golfer where to place the at least one ball for a second shot related to the virtual golf hole.

In accordance with a forty-eighth aspect of the present disclosure, which may be used in combination with any other aspect or combination of aspects listed herein, a system includes a control unit programmed to perform the method for playing the golf game within limited confines.

In accordance with a forty-ninth aspect of the present disclosure, which may be used in combination with any other aspect or combination of aspects listed herein, a method for playing a golf game within limited confines includes generating a virtual golf hole, calculating a landing location related to the virtual golf hole based on of a first shot physically hit by the golfer, and adjusting a putting green surface based on a landing location so that the golfer can physically hit a second shot using the putting green surface.

In accordance with a fiftieth aspect of the present disclosure, which may be used in combination with any other aspect or combination of aspects listed herein, a system includes a control unit programmed to perform the method for playing the golf game within limited confines.

In accordance with a fifty-first aspect of the present disclosure, which may be used in combination with any other aspect or combination of aspects listed herein, a method for playing a golf game within limited confines includes generating a virtual golf hole, after a golfer physically hits a first ball from a floor unit into a wall unit, calculating a landing location related to the virtual golf hole, and adjusting the floor unit for use with a second ball, which is different from the first ball, based on the landing location.

In accordance with a fifty-second aspect of the present disclosure, which may be used in combination with any other aspect or combination of aspects listed herein, a system includes a control unit programmed to perform the method for playing the golf game within limited confines.

In accordance with a fifty-third aspect of the present disclosure, which may be used in combination with any other aspect or combination of aspects listed herein, a floor unit for playing a golf game within limited confines includes a hitting portion including at least one hitting surface, a putting portion including a putting green surface, and a control portion configured to adjust the putting green surface.

In accordance with a fifty-fourth aspect of the present disclosure, which may be used in combination with any other aspect or combination of aspects listed herein, the hitting portion includes at least one of: (i) a fairway hitting surface; (ii) a rough hitting surface; and (iii) a sand hitting surface.

In accordance with a fifty-fifth aspect of the present disclosure, which may be used in combination with any other aspect or combination of aspects listed herein, the putting portion includes a plurality of putting green surface adjusters configured to adjust a surface contour of the putting green surface.

In accordance with a fifty-sixth aspect of the present disclosure, which may be used in combination with any other aspect or combination of aspects listed herein, the control portion includes a control unit programmed to con-

trol the plurality of putting green surface adjusters configured to adjust the surface contour of the putting green surface.

In accordance with a fifty-seventh aspect of the present disclosure, which may be used in combination with any other aspect or combination of aspects listed herein, at least one of the hitting portion or the putting portion includes a transceiver configured to receive a signal from a golf ball configured for use with the floor unit.

In accordance with a fifty-eighth aspect of the present disclosure, which may be used in combination with any other aspect or combination of aspects listed herein, a wall unit for playing a golf game within limited confines includes a display portion configured to display a virtual portion of the golf game, and a sensor portion configured to generate data related to a physical portion of the golf game, the generated data being used to adjust display of the virtual portion.

In accordance with a fifty-ninth aspect of the present disclosure, which may be used in combination with any other aspect or combination of aspects listed herein, the sensor portion includes a plurality of sensors, the plurality of sensors including at least one of a proximity sensor or an impact sensor.

In accordance with a sixtieth aspect of the present disclosure, which may be used in combination with any other aspect or combination of aspects listed herein, a putting green surface adjuster configured to adjust a surface contour of a putting green surface in combination other putting green surface adjusters includes a base portion configured to adjust in height, and a surface supporting portion configured to support the putting green surface, the surface supporting portion further configured to rotate and/or tilt with respect to the base portion.

In accordance with a sixty-first aspect of the present disclosure, which may be used in combination with any other aspect or combination of aspects listed herein, the base portion includes a bottom part and a top part, the top part configured to be raised or lowered with respect to the bottom part to adjust the height of the base portion.

In accordance with a sixty-second aspect of the present disclosure, which may be used in combination with any other aspect or combination of aspects listed herein, the base portion includes an actuator configured to cause the relative movement of the bottom part and the top part.

In accordance with a sixty-third aspect of the present disclosure, which may be used in combination with any other aspect or combination of aspects listed herein, the putting green surface adjuster includes at least one of a transceiver or a light.

In accordance with a sixty-fourth aspect of the present disclosure, which may be used in combination with any other aspect or combination of aspects listed herein, the putting green surface adjuster includes an electrical contact configured to place at least one electrical element therein in electrical communication with a control unit.

In accordance with a sixty-fifth aspect of the present disclosure, which may be used in combination with any other aspect or combination of aspects listed herein, the surface supporting portion includes an aperture which forms a ball joint with a bulbous portion of the base portion.

In accordance with a sixty-sixth aspect of the present disclosure, which may be used in combination with any other aspect or combination of aspects listed herein, a control unit is programmed to control the putting green surface adjuster to adjust the surface contour of a putting green surface.

In accordance with a sixty-seventh aspect of the present disclosure, which may be used in combination with any other aspect or combination of aspects listed herein, a control unit is programmed to control a plurality of the putting green surface adjusters to adjust the surface contour of a putting green surface.

In accordance with a sixty-eighth aspect of the present disclosure, which may be used in combination with any other aspect or combination of aspects listed herein, a control unit is programmed to detect the presence of a golf ball on a floor unit, and to use data regarding the location of the golf ball to calculate a landing location for the golf ball on a virtual golf hole.

In accordance with a sixty-ninth aspect of the present disclosure, which may be used in combination with any other aspect or combination of aspects listed herein, a golf ball includes a sensor configured for use with the system.

In accordance with a seventieth aspect of the present disclosure, which may be used in combination with any other aspect or combination of aspects listed herein, a set of golf balls is configured for use with the system, the set of golf balls including a first golf ball and a second golf ball, the first ball different from the second ball.

In accordance with a seventy-first aspect of the present disclosure, which may be used in combination with any other aspect or combination of aspects listed herein, a headset configured for playing a golf game within limited confines includes a frame configured to be positioned on a golfer's head, and at least one display screen configured to display a virtual portion of the golf game to the golfer while the golfer plays a physical portion of the golf game.

In accordance with a seventy-second aspect of the present disclosure, which may be used in combination with any other aspect or combination of aspects listed herein, the headset includes a processor and a memory, and the processor is configured to execute instructions stored on the memory to cause the virtual portion of the golf game.

In accordance with a seventy-third aspect of the present disclosure, which may be used in combination with any other aspect or combination of aspects listed herein, the headset includes a data transmission device configured to receive information regarding the virtual portion of the golf game.

In accordance with a seventy-fourth aspect of the present disclosure, which may be used in combination with any other aspect or combination of aspects listed herein, the headset is configured to alternate between a transparent mode and a virtual mode.

In accordance with a seventy-fifth aspect of the present disclosure, which may be used in combination with any other aspect or combination of aspects listed herein, the headset includes a motion sensor, and the headset is configured to alternate between the transparent mode and the virtual mode based on information from the motion sensor.

In accordance with a seventy-sixth aspect of the present disclosure, which may be used in combination with any other aspect or combination of aspects listed herein, the headset is configured to alternate between a striking mode and a putting mode.

In accordance with a seventy-seventh aspect of the present disclosure, which may be used in combination with any other aspect or combination of aspects listed herein, a system in accordance with a previous embodiment includes a headset configured to display at least one image related to the virtual portion of the golf game.

In accordance with a seventy-eighth aspect of the present disclosure, which may be used in combination with any

other aspect or combination of aspects listed herein, a system in accordance with a previous embodiment includes a headset configured to display at least one image related to the virtual portion of the golf game.

In accordance with a seventy-ninth aspect of the present disclosure, which may be used in combination with any other aspect or combination of aspects listed herein, a method in accordance with a previous embodiment includes adjusting at least one image of the virtual golf hole on a display screen of a headset.

In accordance with an eightieth aspect of the present disclosure, which may be used in combination with any other aspect or combination of aspects listed herein, a method in accordance with a previous embodiment includes adjusting at least one image of the virtual golf hole on a display screen of a headset.

In accordance with an eighty-first aspect of the present disclosure, which may be used in combination with any other aspect or combination of aspects listed herein, a method in accordance with a previous embodiment includes adjusting at least one image of the virtual golf hole on a display screen of a headset.

In accordance with an eighty-second aspect of the present disclosure, which may be used in combination with any other aspect or combination of aspects listed herein, a system for playing a golf game within limited confines includes a floor unit in accordance with a previous embodiment and a headset in communication with the floor unit, the headset including a display screen configured to display at least one image while a golfer physically uses the floor unit.

In accordance with an eighty-third aspect of the present disclosure, which may be used in combination with any other aspect or combination of aspects listed herein, a system for playing a golf game within limited confines includes a wall unit in accordance with a previous embodiment and a headset in communication with the wall unit, the headset including a display screen configured to display at least one image related to the virtual portion of the golf game.

In accordance with an eighty-fourth aspect of the present disclosure, which may be used in combination with any other aspect or combination of aspects listed herein, a system for playing a sport within limited confines includes a wall unit configured to display a virtual portion of the sport, a floor unit configured to enable a physical portion of the sport, and a control unit programmed to use first data related the virtual portion and second data related to the physical portion to enable a user to play the sport.

In accordance with an eighty-fifth aspect of the present disclosure, which may be used in combination with any other aspect or combination of aspects listed herein, the sport is golf, baseball, basketball, football (American or European style), volleyball, softball, dodgeball, handball, racquetball, paddleball, hockey, tennis, or another sport.

What is claimed is:

1. A system for playing a golf game within limited confines, the system comprising:

a wall unit configured to display a virtual portion of the golf game and be struck by at least one ball, the wall unit including at least one wall sensor configured to generate unit data when the wall unit is struck by the at least one ball;

a floor unit configured to enable a physical portion of the golf game, the floor unit including a hitting portion for hitting the at least one ball into the wall unit and a

putting portion having a putting green surface for physically putting a final one or more shot of a golf hole; and

a control unit programmed to: (i) provide a golfer with a user interface including a plurality of indicators, the plurality of indicators configured to enable the golfer to calibrate the golf game in a plurality of categories which relate a level of skill of the golfer to at least two ball or course conditions; (ii) calibrate the golf game for the golfer by setting a plurality of weights based on adjustments by the golfer to the plurality of indicators, the plurality of weights affecting how virtual flight paths deviate from true flight paths of the at least one ball when the golfer hits the at least one ball from the floor unit into the wall unit; (iii) use the plurality of weights, with the unit data generated when the at least one ball is hit from the hitting portion into the wall unit and with course data related to the virtual portion of the golf game, to calculate a flight path and determine a landing location for the at least one ball when the at least one ball is hit from the hitting portion into the wall unit; and (iv) based on the landing location, instruct a golfer where to place the at least one ball on the floor unit for the final one or more shot of the golf hole using the putting green surface.

2. The system of claim 1, wherein the at least one ball includes a first ball and a second ball, the first ball configured to be hit by the golfer from the floor unit into the wall unit, the second ball configured to be putted by the golfer on the floor unit, the first ball differing in weight and/or density in comparison to the second ball.

3. The system of claim 1, the at least one ball including at least one ball sensor configured to measure at least one of a spin rate, a speed, or an acceleration of the at least one ball.

4. The system of claim 1, the at least one ball including a transceiver.

5. The system of claim 1, wherein the floor unit includes a plurality of putting green surface adjusters configured to adjust a surface contour of the putting green surface.

6. The system of claim 1, wherein the at least one ball includes a first ball and a second ball, the first ball different from the second ball, and the control unit is programmed to (i) calculate The landing location on a virtual golf hole after the first ball is hit from the hitting portion into the wall unit, (ii) instruct the golfer where to place the first ball on the floor unit to again be struck into the wall unit when the landing location is outside of a predetermined area of the virtual golf hole, and (iii) instruct the golfer where to place the second ball on the floor unit when the landing location is within the predetermined area of the virtual golf hole.

7. The system of claim 1, wherein the unit data includes data regarding a location where the at least one ball struck the wall unit.

8. The system of claim 1, wherein the unit data includes data regarding a magnitude of impact of the at least one ball striking the wall unit.

9. A system for playing a golf game within limited confines, the system comprising:

- a wall unit configured to display a virtual portion of the golf game and be struck by a first ball;
- a floor unit configured to enable a physical portion of the golf game, the floor unit including a hitting portion for hitting the first ball into the wall unit and a putting portion having a putting green surface for putting a second ball;
- the first ball having an outer surface that includes a foam or rubber material, the first ball configured to be hit by

the golfer from the floor unit into the wall unit, the first ball including at least one first ball sensor configured to generate first ball data when the first ball is hit from the floor unit into the wall unit; the second ball being different from the first ball and having an outer surface that includes a resin material,

the second ball configured to be putted by the golfer on the floor unit; and

a control unit programmed to (i) use the first ball data in a calculation of a landing location on a virtual golf hole after the first ball is hit from the hitting portion into the wall unit, (ii) instruct the golfer where to place the first ball on the floor unit to again be struck into the wall unit when the landing location is outside of a predetermined area of the virtual golf hole, and (iii) instruct the golfer where to place the second ball on the floor unit when the landing location is within the predetermined area of the virtual golf hole.

10. The system of claim 9, wherein the first ball differs in weight and/or density in comparison to the second ball.

11. The system of claim 9, wherein the at least one first ball sensor includes a proximity sensor which can be detected by one or more transceiver located in the floor unit or the wall unit.

12. The system of claim 9, wherein the at least one first ball sensor includes at least one sensor configured to measure at least one of a spin rate, a speed or an acceleration of the first ball.

13. The system of claim 9, wherein the at least one first ball sensor includes a transceiver.

14. The system of claim 9, wherein the control unit is programmed to calculate a flight path of the first ball hit by the golfer from the floor unit into the wall unit using the first ball data with unit data generated by at least one sensor of at least one of the floor unit or the wall unit.

15. The system of claim 9, wherein the wall unit includes at least one wall sensor configured to interact with the at least one first ball sensor of the first ball.

16. The system of claim 9, wherein the second ball includes at least one second sensor configured to generate second ball data when the second ball is used on the putting green surface, and the control unit is programmed to use the second ball data to determine when the golfer has completed the virtual golf hole.

17. A method for playing a golf game using a system that includes a wall unit configured to display a virtual portion of the golf game and be struck by at least one ball, a floor unit configured to enable a golfer to hit the at least one ball into the wall unit, and a control unit configured to enable a user to calibrate the system, the method comprising:

- providing the golfer with a user interface including a plurality of indicators, the plurality of indicators configured to enable the golfer to calibrate the golf game in a plurality of categories which relate a level of skill of the golfer to at least two ball or course conditions; calibrating the golf game for the golfer by setting a plurality of weights based on adjustments by the golfer to the plurality of indicators, the plurality of weights affecting how virtual flight paths deviate from true flight paths of the at least one ball when the golfer hits the at least one ball from the floor unit into the wall unit;
- generating a virtual golf hole;
- using the plurality of weights, calculating a flight path and determining a landing location on the virtual golf hole based on sensor data regarding the at least one

ball being physically hit from the floor unit into the wall unit by the golfer during a first shot related to the virtual golf hole; and
instructing the golfer where to place the at least one ball on the floor unit for a physical second shot based on the landing location. 5

18. The system including the control unit programmed to perform the method of claim 17.

19. The method of claim 17, which includes adjusting a putting green surface based on the landing location so that the golfer can physically hit the second shot using the putting green surface. 10

20. The method of claim 19, which includes instructing the golfer where to place the at least one ball relative to the putting green surface for the second shot. 15

* * * * *