

(No Model.)

2 Sheets—Sheet 1.

J. CORZILIUS.  
PILE FABRIC LOOM.

No. 522,931.

Patented July 10, 1894.

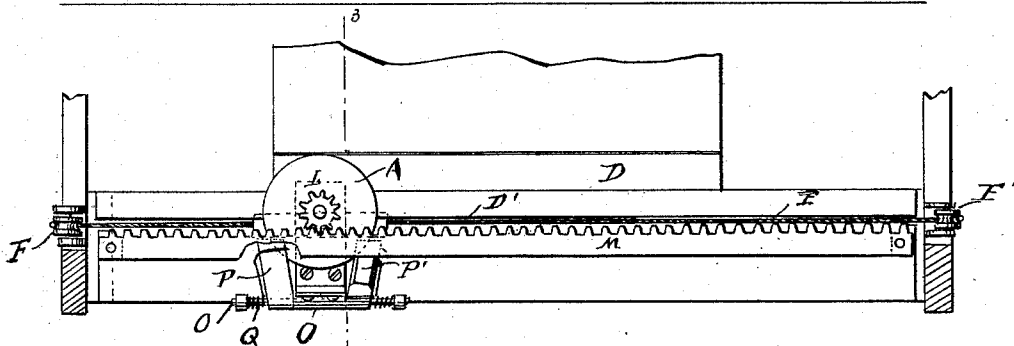
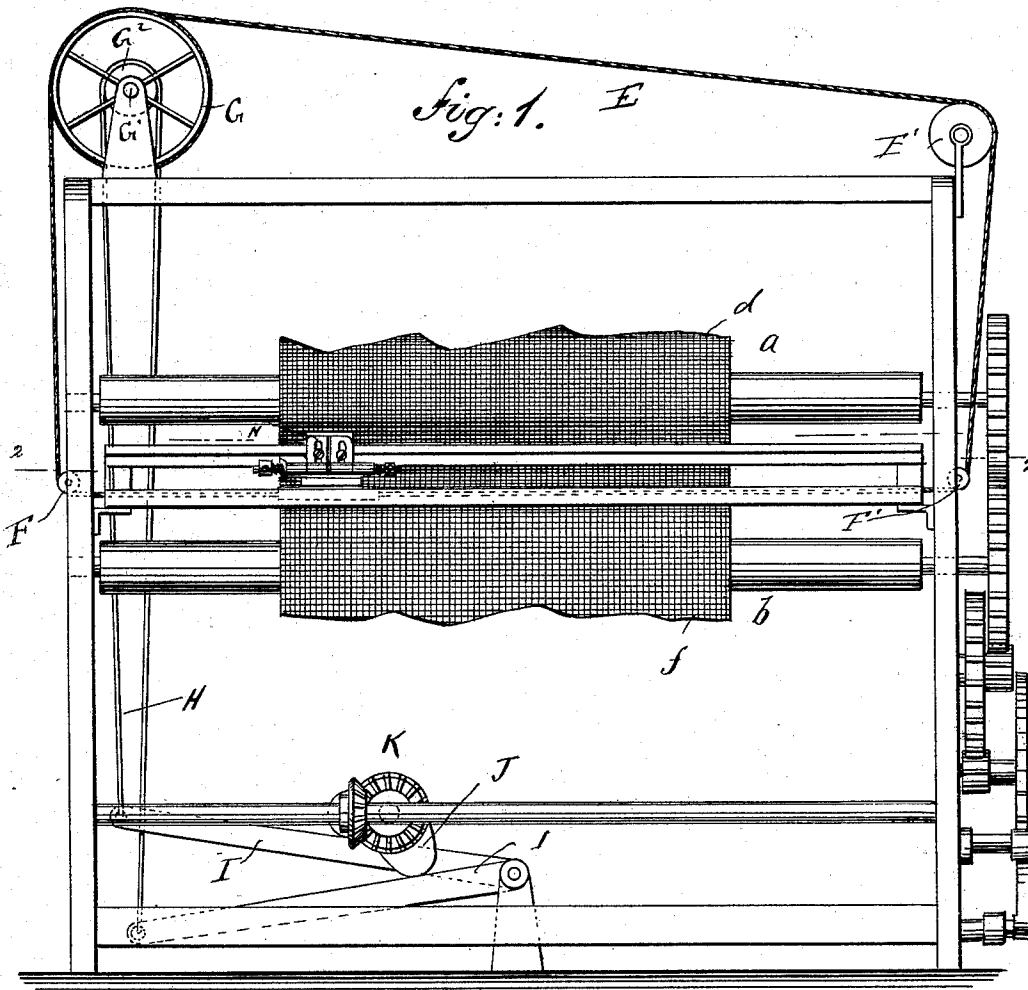

WITNESSES:  
*Chas. Kabley.*  
*Otto Reiss*

*Fig. 2.*

INVENTOR  
*J. Corzilius*  
 BY *August H. Meyer*

ATTORNEYS.

J. CORZILIUS.  
PILE FABRIC LOOM.

No. 522,931.

Patented July 10, 1894.

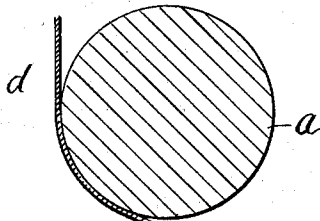

*Fig: 3.*

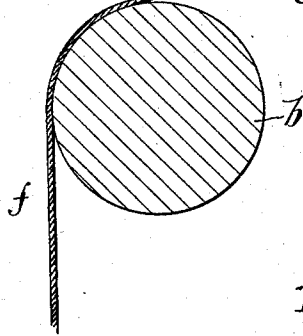
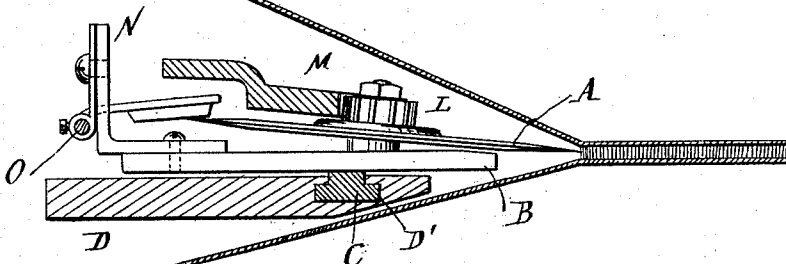

*Fig: 5.*

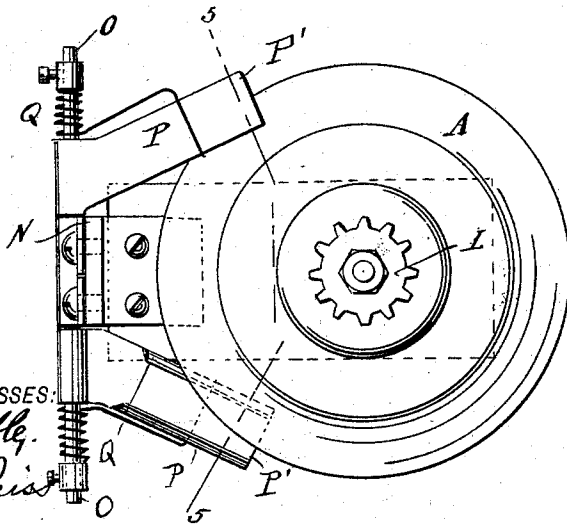
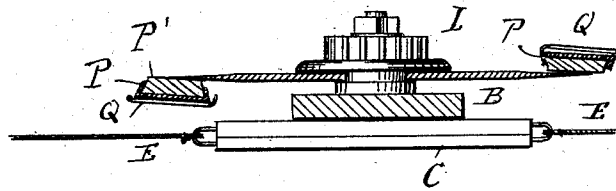

*Fig: 7.*

WITNESSES:  
*Chas. Kable,*  
*Otto Reiss,*

INVENTOR  
*J. Corzilius*  
 BY *Georgel Rueymer*  
 ATTORNEYS.

# UNITED STATES PATENT OFFICE.

JAKOB CORZILIUS, OF PATERSON, NEW JERSEY.

## PILE-FABRIC LOOM.

SPECIFICATION forming part of Letters Patent No. 522,931, dated July 10, 1894.

Application filed September 16, 1893. Serial No. 485,703. (No model.)

*To all whom it may concern:*

Be it known that I, JAKOB CORZILIUS, a subject of the Emperor of Germany, and a resident of Paterson, in the county of Passaic and State of New Jersey, have invented certain new and useful Improvements in Pile-Fabric Looms, of which the following is a specification.

This invention relates to improvements in pile-fabric looms, and especially to that class of such looms in which two pieces of pile fabrics are woven at the same time and are separated by a knife which cuts the pile threads, so as to form two pieces.

The object of my invention is to provide a device for automatically sharpening the knife while the same travels to and fro.

The invention consists in the combination with the weaving parts of a loom, of a suitable track, a carriage mounted on the same, a rotary knife mounted on the carriage, holders for abrading stones hinged on the carriage, springs acting on said holders to press the stones in contact with the rotary knife and means for rotating the knife.

The invention also consists in the construction and combination of parts and details, which will be fully described hereinafter and finally pointed out in the claim.

In the accompanying drawings, Figure 1 is a front elevation of my improved loom, with the cutting attachment, parts being broken out. Fig. 2 is a horizontal sectional view, on the line 2 2, Fig. 1. Fig. 3 is a vertical transverse sectional view, on the line 3 3, Fig. 2. Fig. 4 is an enlarged detail plan-view of the cutting attachment, and Fig. 5 is a longitudinal vertical sectional view of the same on the line 5 5, of Fig. 4.

Similar letters of reference indicate corresponding parts.

The circular cutting blade or dish A is mounted with a slight inclination on the traveling carriage B, which is provided in its under side with a headed tenon C that travels in a longitudinal groove D' formed in the top of a rail D fastened in the loom frame between the two guide rollers *a b* for the two pieces of plush fabric *d f*.

The ends of a wire or cord E are fastened to opposite ends of the tenon C, run along the groove D' and at the ends of the rail D

pass over pulleys F in the frame of the loom and then are passed several times around the large pulley G fixed on a shaft G' journaled on the top of the loom frame, which shaft G' also carries a smaller pulley G<sup>2</sup>. The wire or cord E then passes over a pulley E' at the opposite side of the loom frame and over a pulley F' at the end of the rail D.

A strap H passes over the pulley G<sup>2</sup> and its ends are secured to two treadles I, which are operated by tappets J driven by means of the bevel gearing K from the driving gearing of the loom.

The cutting disk carries on its top a pinion L that engages a rack M arranged above the rail D and extending over part of the rotating cutting disk.

The carriage is provided on its rear edge with a standard N carrying a shaft O, on which are mounted two swinging supports P for whet-stones P' or like abrading devices. The holders P are provided with flanges to form sockets, into which the ends of the whet-stones can be slipped. The pockets P are so arranged that one is on the upper surface of the rotary cutting disk and the other below the same. Suitable springs Q act on the said pockets or holders P and press the whet-stones in the same against the surface of the knife.

As the loom is operated the bevel gearing K is also operated, and by means of the tappets J alternately depresses the two pedals I. Thereby the pulley G is alternately rocked in one direction or the other and thus the carriage B is moved from right to left, then from left to right, and so on. As the carriage moves in this manner the knife is rotated by the co-action of the rack M and pinion L and cuts the pile threads uniting the two layers of fabrics, thus forming the two separate pieces of plush *d f* or like fabric. As the knife rotates it is constantly sharpened by the abrading stones, of which one rests on the upper and the other on the lower surface of the knife.

Having thus described my invention, I claim as new and desire to secure by Letters Patent—

The combination with a carriage and means for guiding and reciprocating the same, of a circular knife mounted to rotate on said carriage, a pinion connected with said circular

knife, a fixed rack engaging said pinion, two  
whetstone holders hinged to the carriage, one  
above and the other below the knife, and  
springs acting on said whetstone holders to  
5 press the whet-stones in the same in contact  
with the knife substantially as set forth.  
In testimony that I claim the foregoing as

my invention I have signed my name in pres-  
ence of two subscribing witnesses.

JAKOB CORZILIUS.

Witnesses:

PEETER KORZILIUS,  
JACOB SMETS.