

Luther & Buck,

Manf. Whips.

No. 104,970.

Patented July 5, 1870.

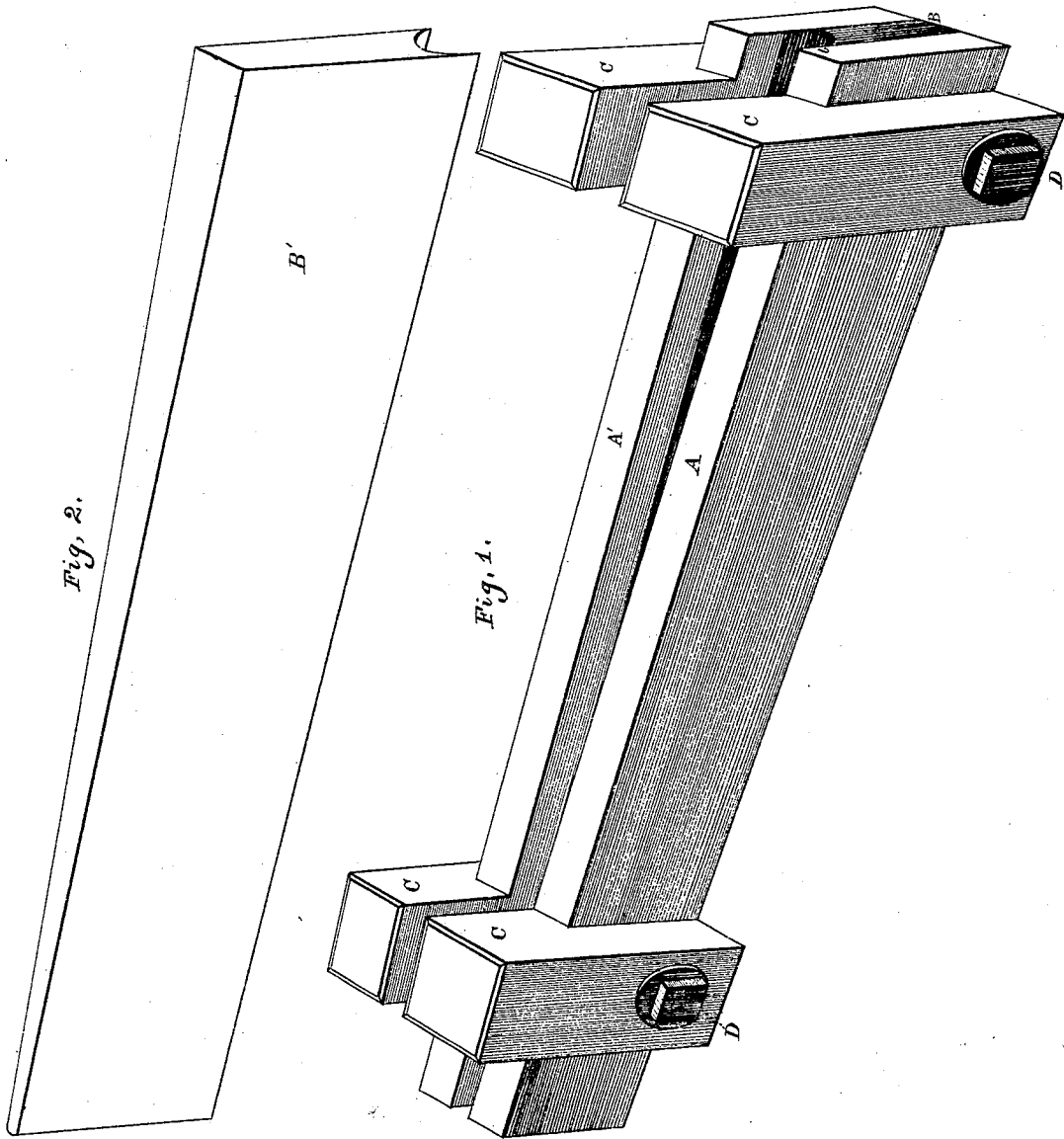

Witnesses,

H. A. Daniels  
J. W. Hester

J. P. Luther & S. K. Buck Inventor, by  
W. S. Whitman Attorney

# UNITED STATES PATENT OFFICE.

JUSTUS P. LUTHER AND SOLON K. BUCK, OF BERLIN, WISCONSIN.

## IMPROVED CLAMP FOR MAKING WHIPS.

Specification forming part of Letters Patent No. **104,970**, dated July 5, 1870.

Know all men that we, JUSTUS P. LUTHER and SOLON K. BUCK, both of the city of Berlin, county of Green Lake, and State of Wisconsin, have invented a new and Improved Implement for Making Leather Whip-Stocks; and we hereby declare the following to be a full, clear, and exact description thereof, reference being had to the accompanying drawing, in which—

Figure 1 is a representation of the bottom section of the mold used in pressing and molding the stocks, and Fig. 2 is a representation of the top section of said mold.

Said drawing and the figures of reference marked thereon are hereby made a part of this specification.

My invention relates to presses made use of for the purpose of manufacturing leather whip stocks; and the nature thereof consists in so arranging the parts composing the frame of the press that the wedge-shaped press-stocks made use of may be constructed of a different kind of material from the other component parts of the implement.

The construction, operation, and relative arrangement of the component parts of my invention are as follows:

Between the longitudinal beams A A' is secured the wedge B, the upper side of which is provided with an elongated groove of the form of a semi-truncated cone. The said lon-

gitudinal beams and wedge are firmly bound together by means of the upright clamp-bars *c c* and *c' c'* and the bolts D, which pass through perforations cut for their reception, and are secured in position by nuts and washers.

The wedge-piece B' is similar in construction to the wedge-piece B, and is arranged to fit within the opening between the upper ends of the clamp-blocks *c c* and *c' c'*.

The strips of leather of which the whip-stock is to be made are then placed together and dipped in glue or other cementing substance, as in ordinary known modes of stocking, and are laid in the bottom section of the mold, Fig. 1. The top section, Fig. 2, is then placed over them and pressed down by any suitable lever-power.

We claim—

An implement for making leather whip-stocks consisting of the arrangement herein specified, of the wedge-pieces B B', longitudinal bars A A', upright clamp-blocks *c c* and *c' c'*, and transverse bolts D D', when constructed and operating as described and shown.

JUSTUS P. LUTHER.  
SOLON K. BUCK.

Witnesses:

THOS. C. RYAN,  
MICHAEL A. HURLEY.