

J. S. HULL.

Petroleum Cooking and Heating Apparatus.

No. 58,260.

Patented Sept. 25, 1866.

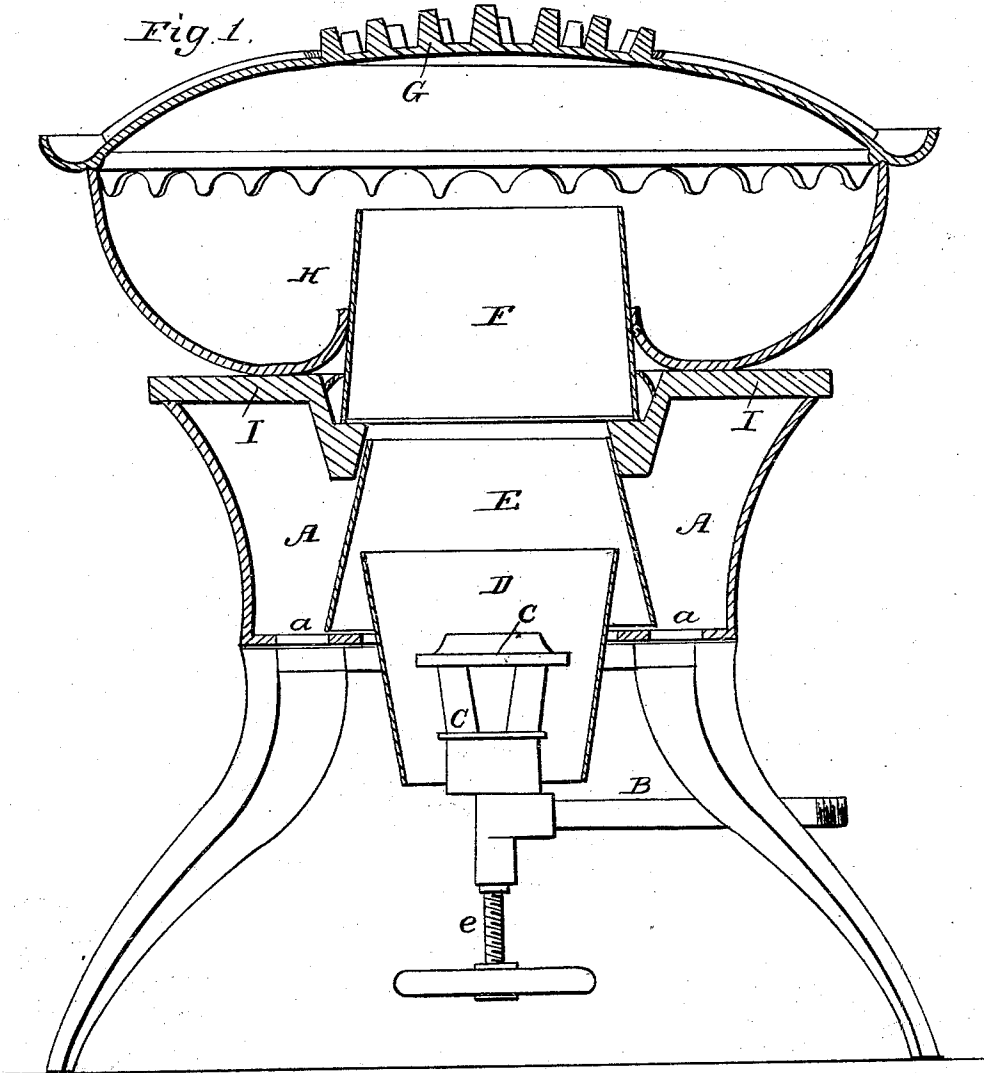

Witnesses:
Wm. Frank Brown
A. J. Hoyt

Inventor:
John S. Hull
By his atty
J. H. Brown

J. S. HULL.

Petroleum Cooking and Heating Apparatus.

No. 58,260.

Patented Sept. 25, 1866.

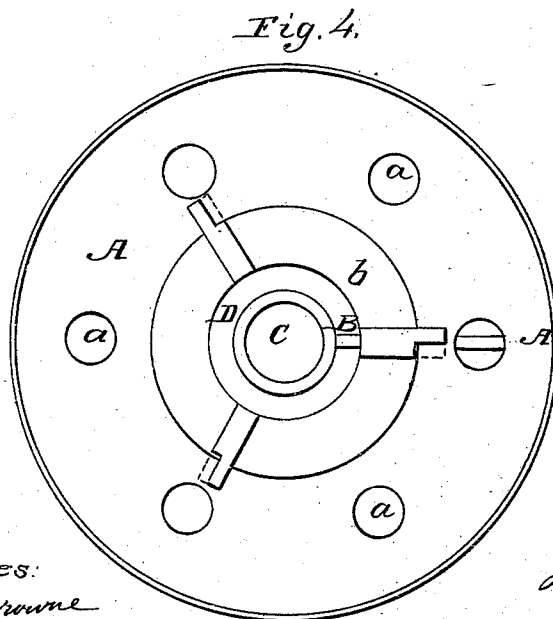
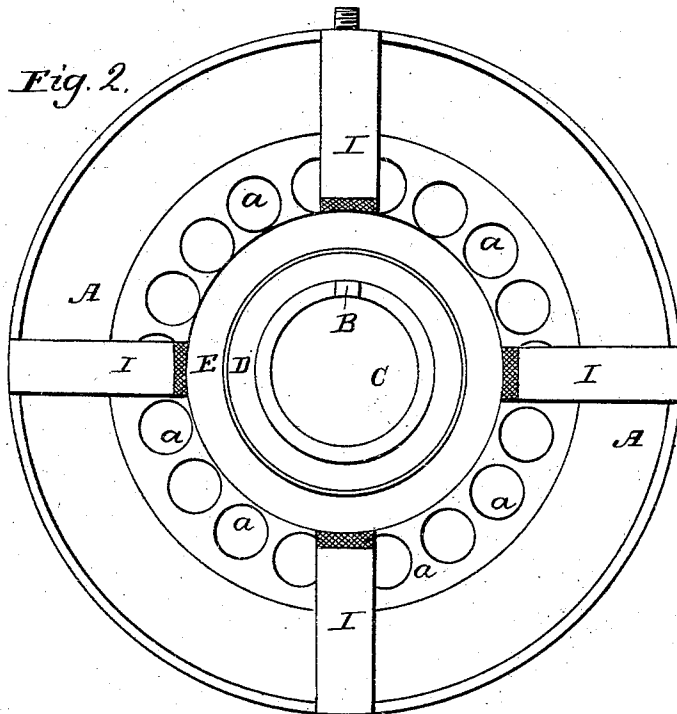

Witnesses:
Wm. Frank Browne
A. J. Coyle

Inventor:
John S. Hull,
 By his Att'y.
J. L. Brown

J. S. HULL.

Petroleum Cooking and Heating Apparatus.

No. 58,260.

Patented Sept. 25, 1866.

Fig. 3.

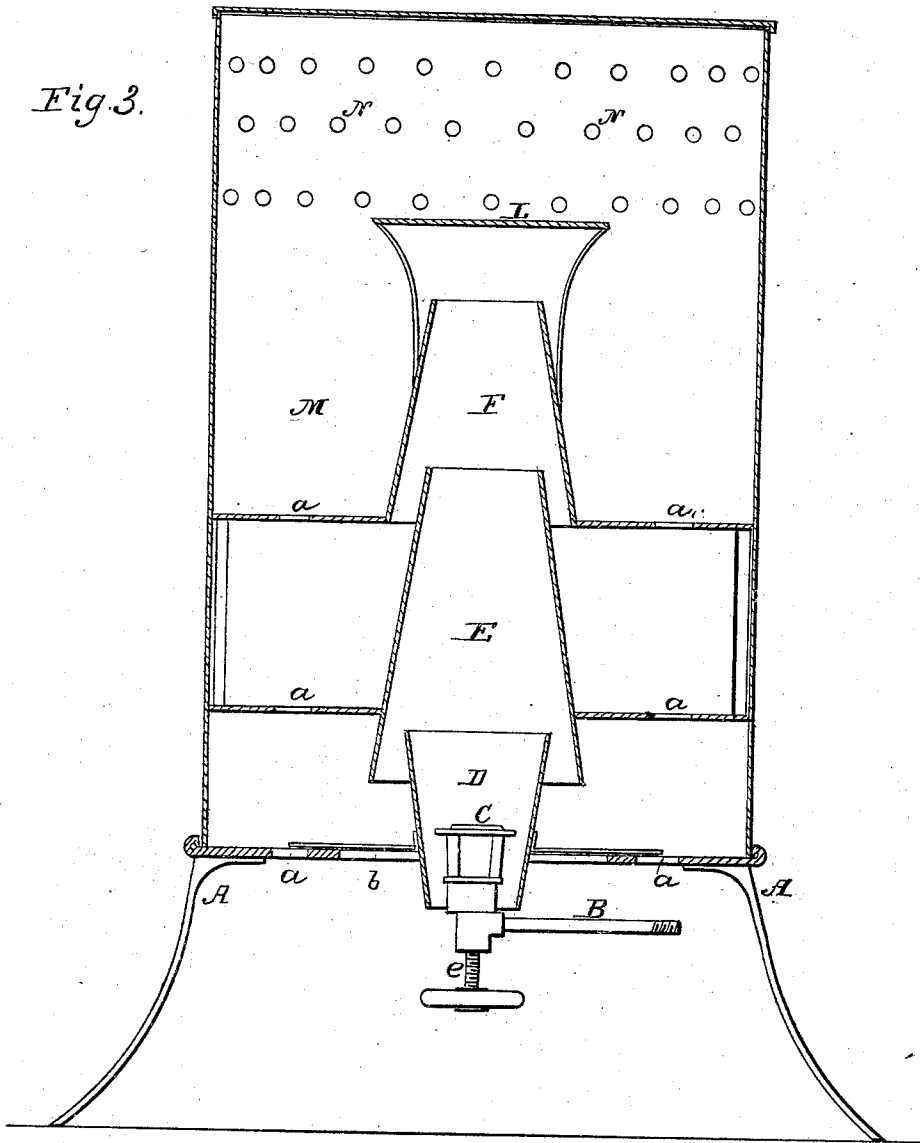

Witnesses:
 Wm. Frank Brown
 A. J. Hoop

Inventor:
 John S. Hull
 By his atty.
 J. Brown

UNITED STATES PATENT OFFICE.

JOHN S. HULL, OF CINCINNATI, OHIO.

IMPROVEMENT IN PETROLEUM COOKING AND HEATING APPARATUS.

Specification forming part of Letters Patent No. 58,260, dated September 25, 1866.

To all whom it may concern:

Be it known that I, JOHN S. HULL, of Cincinnati, in the county of Hamilton and State of Ohio, have invented a new and Improved Apparatus for Cooking and Heating with Petroleum or other Hydrocarbon Fluids; and I do hereby declare that the following is a full and exact description thereof, reference being had to the accompanying drawings, making part of this specification—

Figure 1 being a central vertical section of the apparatus as arranged for cooking; Fig. 2, a plan thereof, the cooking utensil being removed; Fig. 3, a central vertical section of the apparatus as arranged simply for heating; Fig. 4, a plan of the lower part thereof, including the burner.

Like letters designate corresponding parts in all of the figures.

In this apparatus I force the oil or other hydrocarbon fluid to the burner C through a pipe, B, from a reservoir in which atmospheric pressure is employed by condensation to drive the oil to the burner. The burner gasifies the oil as it passes through its retort over and within the flame, so that a blowing jet of flame is produced, which may be varied in intensity by increasing or diminishing the force of pressure in the reservoir, or by adjusting the needle-point regulator *c* of the jet-orifice.

I lengthen or extend upward the flame as it issues from the burner to any required distance by means of a succession of short open tubes, D E F, arranged and operating substantially as follows: The lower tube, D, surrounds the burner C about as shown, and it is somewhat conical or flaring in shape, the narrow end being downward, in order to limit the amount of draft arising through it to a certain extent, and to prevent an unnecessary loss of heat from the burner by radiation downward through it.

The second tube, E, is also more or less conical or flaring; but its larger end is downward, in order to admit an additional supply of draft air from below to enhance the combustion in the flame. The upper end is of less diameter, in order to enter the lower end

of the next higher tube a little distance, and that next tube is made broader at the bottom to receive the upper end of the tube below and furnish space for the admission of more draft air. Then whatever the number of succeeding tubes above, they are all constructed and arranged substantially as the second tube, E, till the last tube, F, is reached, which may be either of the same shape as shown in Fig. 3, or nearly cylindrical, as shown in Fig. 1.

By means of these successive open tubes thus arranged, and in turn admitting additional fresh draft-air, I am enabled not only to carry the flame upward as far as desired, but to make the combustion perfect and diffuse the heat thereof through or upon the desired amount of space or surface. Thus, for cooking, the heat is evenly spread out against the vessel or utensil, however large its surface—as, for instance, in the case of the gridiron C, (shown in Fig. 1;) and for heating the advantage is still more obvious, since the extended and enlarged flame radiates or conducts heat to the whole interior surface of the heating-drum M, which surrounds the burner and draft-tubes.

The apparatus is supported by a suitable stand, A, which may be large enough to receive several burners. Upon this stand, for cooking, a removable spider, I, is employed to support the cooking utensils above, as indicated by the gravy-dish H, Fig. 1, of the broiler.

If the bottom of the apparatus around the burner is closed or covered there should be sufficient apertures *a a* to admit the required supply of draft air from below to introduce into the flame-tubes.

In heating, if the flame-tubes and burner are inclosed by a close radiating drum or case, M, there should be apertures N N through it at or near the top to allow the free escape of the products of combustion; or, if desired, a pipe may be employed to conduct them to the flue of the chimney or out of doors.

What I claim as my invention, and desire to secure by Letters Patent, is—

1. The open inverted conical tube D around

the burner C, in combination therewith, and with the tubes E F, arranged and operating substantially as and for the purpose herein specified.

2. The succession of open tubes E F, formed, arranged, and operating substantially as and for the purpose herein set forth.

3. The combination of a burner provided

with open tubes D E F, as described, with a cooking or heating apparatus or utensil.

The above specification signed by me this 9th day of January, 1866.

JOHN S. HULL.

Witnesses:

T. J. TELNEY,

JNO. S. KIDD.