



(51) International Patent Classification:

B29C 49/46 (2006.01) B29C 49/64 (2006.01)
B29C 49/06 (2006.01) B29L 31/00 (2006.01)
B29C 49/36 (2006.01)

(21) International Application Number:

PCT/EP2019/082194

(22) International Filing Date:

22 November 2019 (22.11.2019)

(25) Filing Language:

English

(26) Publication Language:

English

(30) Priority Data:

18306681.0 13 December 2018 (13.12.2018) EP

(71) Applicant: **SIDEL PARTICIPATIONS** [FR/FR]; Avenue de la Patrouille de France, 76930 OCTEVILLE-SUR-MER (FR).

(72) Inventors: **CENCI, Mattia**; SIDEL S.p.A. Via La Spezia 241/A, 43126 Parma (IT). **FUSARO, Alessandro**; SIDEL S.p.A. Via La Spezia 241/A, 43126 Parma (IT).

(74) Agent: **SILORET, Patrick**; SIDEL PARTICIPATIONS, Avenue de la Patrouille de France, 76930 OCTEVILLE-SUR-MER (FR).

(81) Designated States (unless otherwise indicated, for every kind of national protection available): AE, AG, AL, AM, AO, AT, AU, AZ, BA, BB, BG, BH, BN, BR, BW, BY, BZ, CA, CH, CL, CN, CO, CR, CU, CZ, DE, DJ, DK, DM, DO, DZ, EC, EE, EG, ES, FI, GB, GD, GE, GH, GM, GT, HN, HR, HU, ID, IL, IN, IR, IS, JO, JP, KE, KG, KH, KN, KP, KR, KW, KZ, LA, LC, LK, LR, LS, LU, LY, MA, MD, ME,

(54) Title: FILLING PLANT AND METHOD FOR PRODUCING BOTTLES AND FILLING BOTTLES WITH A POURABLE PRODUCT

FIG. 2

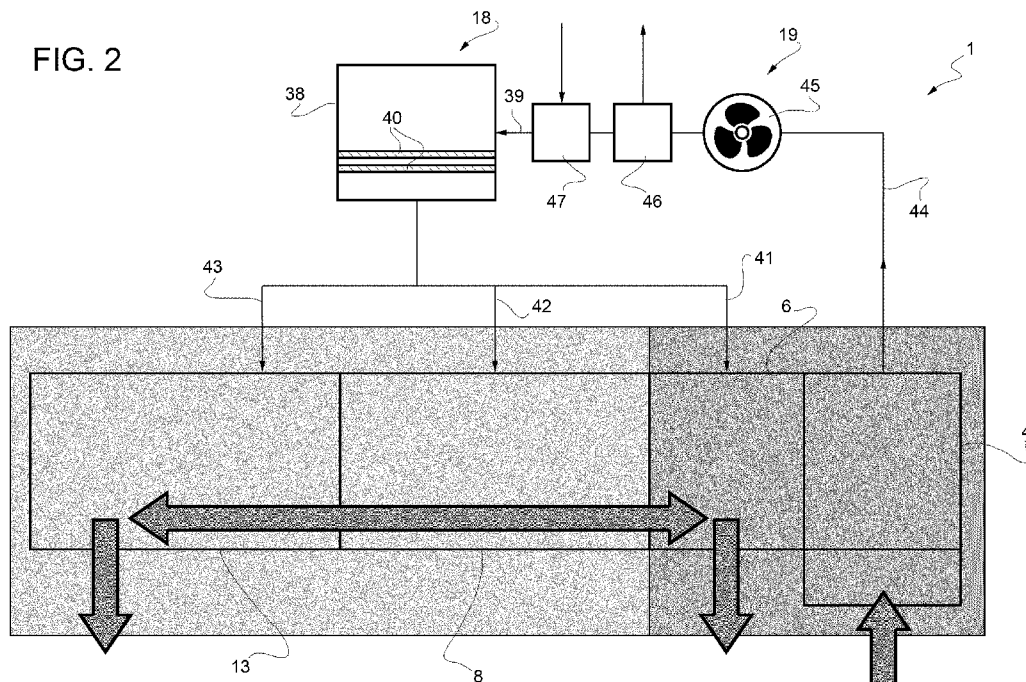

(57) Abstract: There is described a filling plant (1) comprising a pre-heating oven (5) at least partially arranged within a first isolation chamber (4) for pre-heating preforms (3), a first filter unit (17) for filtering a gas to be introduced into the first isolation chamber (4), a molding apparatus (7) being at least partially arranged within a second isolation chamber (6) and configured to mold the preforms (3) into the bottles (2), a filling apparatus (9) being at least partially arranged within a third isolation chamber (8) for filling the bottles (2) within the third isolation chamber (8), a centralized filter unit (18) configured to filter at least a gas for obtaining a filtered gas and to feed at least a first portion of the filtered gas into the second isolation chamber (6) and at least a second portion of the filtered gas into the third isolation chamber (8) and a suction device (19) for extracting gas from the first isolation chamber (4) and to direct at least a portion of the extracted gas to the centralized filter unit (18).



MG, MK, MN, MW, MX, MY, MZ, NA, NG, NI, NO, NZ,
OM, PA, PE, PG, PH, PL, PT, QA, RO, RS, RU, RW, SA,
SC, SD, SE, SG, SK, SL, SM, ST, SV, SY, TH, TJ, TM, TN,
TR, TT, TZ, UA, UG, US, UZ, VC, VN, ZA, ZM, ZW.

- (84) Designated States** (*unless otherwise indicated, for every kind of regional protection available*): ARIPO (BW, GH, GM, KE, LR, LS, MW, MZ, NA, RW, SD, SL, ST, SZ, TZ, UG, ZM, ZW), Eurasian (AM, AZ, BY, KG, KZ, RU, TJ, TM), European (AL, AT, BE, BG, CH, CY, CZ, DE, DK, EE, ES, FI, FR, GB, GR, HR, HU, IE, IS, IT, LT, LU, LV, MC, MK, MT, NL, NO, PL, PT, RO, RS, SE, SI, SK, SM, TR), OAPI (BF, BJ, CF, CG, CI, CM, GA, GN, GQ, GW, KM, ML, MR, NE, SN, TD, TG).

Declarations under Rule 4.17:

- *of inventorship (Rule 4.17(iv))*

Published:

- *with international search report (Art. 21(3))*
-

**FILLING PLANT AND METHOD FOR PRODUCING BOTTLES AND
FILLING BOTTLES WITH A POURABLE PRODUCT**

TECHNICAL FIELD

The present invention relates to a filling plant for
5 producing bottles from preforms and filling bottles with a
pourable product, in particular a pourable food product,
even more particular a sterilized and/or sterile-processed
pourable food products.

The present invention also relates to a method of
10 producing and filling bottles with a pourable product, in
particular a pourable food product, even more particular a
pourable food product, even more particular a sterilized
and/or sterile-processed pourable food products.

BACKGROUND ART

15 Filling plants for producing bottles from preforms and
filling of the bottles with a pourable product, in particular
a pourable food product, even more particular a sterilized
and/or sterile-processed pourable food products, are known.

A typical filling plant comprises at least a first
20 isolation chamber, a pre-heating oven at least partially
arranged within the first isolation chamber and configured
to pre-heat the preforms, a second isolation chamber
connected to the first isolation chamber, a molding apparatus
at least partially arranged within the second isolation
25 chamber and configured to blow or compression mold the

preforms so as to obtain the bottles, a third isolation chamber connected to the second isolation chamber and a filling apparatus at least partially arranged within the third isolation chamber and configured to fill the bottles.

5 A typical filling plant also requires to control the atmosphere within the first, second and third isolation chamber so as to produce under aseptic and/or sterile conditions. For this reason, a typical filling plant comprises a plurality of filter units, each one associated
10 to one of the first, second and third isolation chamber and configured to filter the air to be introduced into the respective of the first, second and third isolation chamber.

Even though, the known filling plants work satisfyingly well, it is the desire to further improve the filling plants
15 and their operation.

In particular, it is a desire to simplify such filling plants and their operation.

In particular, it is another desire to improve the efficiency of such filling plants.

20 DISCLOSURE OF INVENTION

It is therefore an object of the present invention to provide in a straightforward and low-cost manner an improved filling plant for producing bottles from preforms and filling the bottles with a pourable product.

25 It is a further object of the present invention to

provide in a straightforward and low-cost manner an improved method of producing bottles from preforms and filling the bottles with a pourable product.

According to the present invention, there is provided
5 a filling plant and a method according to the independent claims.

Further advantageous embodiments of the filling plant and the method are specified in the dependent claims.

BRIEF DESCRIPTION OF THE DRAWINGS

10 A non-limiting embodiment of the present invention will be described by way of example with reference to the accompanying drawings, in which:

Figure 1 shows a schematic top-view of a filling plant according to the present invention, with parts removed for
15 clarity;

Figure 2 shows a schematic side-view of the filling plant of Figure 1, with parts removed for clarity.

BEST MODES FOR CARRYING OUT THE INVENTION

Referral number 1 indicates as a whole a filling plant
20 for producing and filling bottles, in particular plastic bottles 2, in particular under aseptic conditions.

In particular, filling plant 1 is configured to produce bottles 2 from preforms 3 and to fill bottles 2 with a pourable product, even more particular a pourable food
25 product such as carbonated liquids (e.g. sparkling water,

soft drinks and beer) or non-carbonated liquids (e.g. still water, juices, teas, sport drinks, liquid cleaners, wine, emulsions, suspensions, high viscosity liquids and beverages containing pulps).

5 According to a preferred non-limiting embodiment, filling plant 1 is configured to produce bottles 2 from preforms 3 by means of a molding, in particular a blow or compression molding, process.

 According to a preferred non-limiting embodiment,
10 filling plant 1 is configured to fill a sterilized and/or sterile-processed pourable food product, such as e.g. juices or milk and the like, into bottles 2.

 With particular reference to Figures 1 and 2, filling plant 1 comprises at least:

- 15 - a first isolation chamber 4 containing a defined and/or controlled first (sterile) gas atmosphere;
- a pre-heating oven 5 at least partially arranged within the first isolation chamber 4 and configured to pre-heat preforms 3 within isolation chamber 4;
- 20 - a second isolation chamber 6 containing a defined and/or controlled second (sterile) gas atmosphere;
- a molding apparatus 7 at least partially arranged within isolation chamber 6 and configured to mold preforms 3 into bottles 2, in particular by means of blow or
25 compression molding, within isolation chamber 6;

- a third isolation chamber 8 containing a defined and/or controlled third (sterile) gas atmosphere; and

- a filling apparatus 9 at least partially arranged within third isolation chamber 8 and configured to fill
5 bottles 2 with the pourable product within third isolation chamber 8.

According to a preferred non-limiting embodiment, filling plant 1 also comprises a fourth isolation chamber 13 containing a defined and/or controlled fourth (sterile) gas
10 atmosphere and a capping apparatus 14 at least partially arranged within isolation chamber 13 and configured to receive the filled bottles 2 from filling apparatus 9 and to apply closures onto the filled bottles 2.

According to a preferred non-limiting embodiment, with
15 the term "a defined and/or controlled (sterile) gas atmosphere" is intended to express that the gas atmosphere presents a reduced load of contaminants, in particular for allowing a treating and/or processing of preforms 3 and/or bottle 2 in a sterile environment. Preferentially but not
20 necessarily, the term "a defined and/or controlled (sterile) gas atmosphere" also expresses that the temperature and/or humidity of the gas atmosphere is controlled.

According to a preferred non-limiting embodiment, filling plant 1 also comprises a pre-form sterilization unit
25 15 configured to sterilize at least the inner portion of

preforms 3. In particular, sterilization unit 15 is configured to introduce a sterilization agent into preforms 3 so as to sterilize at least the inner of preforms 3 (and consecutively of bottles 2).

5 According to a preferred non-limiting embodiment, filling plant 1 also comprises a conveying device 16 configured to advance preforms 3 along a first advancement path P and bottles 2 along a second advancement path Q. In particular, conveying device 16 is configured to advance
10 preforms 3 to, through and from pre-heat oven 5 to and at partially through molding apparatus 7 and to advance bottles 2 through and from molding apparatus 7 and at least to and through filling apparatus 9.

Preferentially but not necessarily, conveying device 16
15 is also configured to advance preforms 3 through sterilization unit 15.

Preferentially but not necessarily, conveying device 16 is also configured to advance filled bottles 2 from filling apparatus 9 to and through capping apparatus 14 and out of
20 isolation chamber 13.

With particular reference to Figure 2, filling plant 1 also comprises:

- a first filter unit 17 associated to, in particular connected to, isolation chamber 4 and configured to filter
25 gas, in particular air, even more particular ambient air, to

be introduced into isolation chamber 4, in particular for at least partially defining and/or controlling the first gas atmosphere;

- a centralized filter unit 18 configured to filter the gas, in particular air, so as to obtain a filtered gas, in particular filtered air, and to feed and/or guide at least a first portion and at least a second portion of the filtered gas into respectively isolation chamber 6 and into isolation chamber 8 and/or at least a third portion of the filtered gas into isolation chamber 13; and

- a suction device 19 fluidically connected to isolation chamber 4 and filter unit 18 and configured to extract gas from isolation chamber 4 and to direct at least a portion of the extracted gas to filter unit 18 so that the portion of the extracted gas defines and/or forms at least a portion of the filtered gas and/or the gas to be filtered within filter unit 18 for obtaining the filtered gas.

With particular reference to Figure 1, pre-heat oven 5 comprises a plurality of heating groups 21 arranged within isolation chamber 4 and configured to heat preforms 3, in particular by means of electromagnetic irradiation, even more particular by means of infrared irradiation, during advancement along a heating portion P1 of advancement path P. In particular, heating groups 21 are arranged along heating portion P1.

According to a preferred non-limiting embodiment, conveying device 16 comprises a first conveyer 22 at least partially arranged within isolation chamber 4 and configured to advance preforms 3 (in a manner known as such) within
5 isolation chamber 4 along heating portion P1.

According to a preferred-non-limiting embodiment, molding apparatus 7 comprises a plurality of molding units 26 arranged within isolation chamber 6 and configured to receive preforms 3 and to mold preforms 3 into bottles 2
10 during advancement of preforms 3 along a molding portion P2 of advancement path P.

According to a preferred non-limiting embodiment, conveying device 16 comprises a second conveyor 27 at least partially arranged within isolation chamber 6 and configured
15 to advance preforms 3 within isolation chamber 6 along molding portion P2 and to advance the molded bottles 2 along a first portion Q1 of advancement path Q.

In particular, each molding unit 26 is configured to retain one respective preform 3 during its advancement along
20 molding portion P2 (i.e. prior and during molding of the respective preform 3 into the respective bottle 2) and to retain one respective bottle 2 during advancement of the respective bottle 2 along portion Q1 (i.e. after molding of the respective preform 3 into the respective bottle 2).

25 In the specific example embodiment disclosed, second

conveyor 27 comprises a first conveying carousel configured to rotate around a first rotation axis, in particular having a vertical orientation, and molding portion P2 presents an arc-shaped profile. Molding units 26 are peripherally
5 arranged on the first conveying carousel and equally spaced around the first rotation axis.

According to a preferred non-limiting embodiment, filling apparatus 9 comprises a plurality of filling units (not shown and known as such) arranged within isolation
10 chamber 8 and configured to fill bottles 2 with the pourable product during advancement of bottles 2 along a filling portion Q2 of advancement path Q.

According to a preferred non-limiting embodiment, conveying device 16 comprises a third conveyor 29 at least
15 partially arranged within isolation chamber 8 and configured to advance bottles 2 within isolation chamber 8 along a filling portion Q1 of advancement path Q.

In particular, each filling unit is configured to retain and fill one respective bottle 2 during advancement along
20 filling portion Q2.

In the specific example embodiment disclosed, third conveyor 29 comprises a second conveying carousel configured to rotate around a second rotation axis, in particular parallel to the first rotation axis, and filling portion Q2
25 presents an arc-shaped profile. The filling units are

peripherally arranged on the second conveying carousel and equally spaced around the second rotation axis.

According to a preferred non-limiting embodiment, capping apparatus 14 comprises a plurality of capping units
5 (not shown) arranged within isolation chamber 13 and configured to apply closures onto filled bottles 2.

According to a preferred non-limiting embodiment, conveying apparatus 16 comprises a fourth conveyor 31
10 configured to advance bottles 2 along a capping portion Q3 of advancement path Q.

In particular, each capping unit is configured to apply one respective closure onto one respective bottle 2 during advancement of the respective bottle 2 along capping portion
Q3.

15 In the specific example embodiment disclosed, fourth conveyor 31 comprises a third conveying carousel configured to rotate around a third rotation axis, in particular parallel to the first and second rotation axis, and capping portion Q3 presents an arc-shaped profile. In particular,
20 the capping units are peripherally arranged on the third conveying carousel and equally spaced around the third rotation axis.

According to a preferred non-limiting embodiment, conveying device 16 also comprises a plurality of transfer
25 conveyors 32, in particular transfer star wheels, configured

to advance preforms 3 from first conveyor 22 to second conveyor 27 and from second conveyor 27 to third conveyor 29. Preferentially but not necessarily, some of the transfer conveyors 32 are also configured to transfer bottles 2 from
5 third conveyor 29 to fourth conveyor 31.

According to a preferred non-limiting embodiment, each transfer conveyor 32 is at least partially arranged within one of isolation chamber 4 and 6 and 8 and 13, in particular such that, in use, preforms 3 advance within isolation
10 chambers 4 and 6 and bottles advance within isolation chambers 6, 8 and 13. In other words, at least prior to their closure bottles 2 remain within a controlled and/or defined atmosphere.

According to a preferred non-limiting embodiment,
15 conveying device 16 comprises also one or more outlet conveyors 33, in particular outlet star wheels, configured to advance capped bottles 2 out of isolation chamber 13. Preferentially but not necessarily, each outlet conveyor 33 is at least partially arranged within isolation chamber 13.

20 According to preferred non-limiting embodiment, conveying device 16 also comprises one or more inlet conveyors 34, in particular inlet star wheels, configured to advance preforms 3 into and through sterilization unit 15 and to first conveyor 22.

25 With particular reference to Figures 1 and 2, isolation

chamber 6 is connected to isolation chamber 4 and isolation chamber 8 is connected to isolation chamber 6. In particular, isolation chamber 6 is arranged downstream from isolation chamber 4 along advancement path P and isolation chamber 8 is arranged downstream from isolation chamber 6 along advancement path Q.

According to a preferred non-limiting embodiment, isolation chamber 6 and isolation chamber 4 are connected such that, in use, preforms 3 are transferred from isolation chamber 4 directly into isolation chamber 6, in particular without any particular passage. In other words, preforms 3 are exposed to the first and second gas atmosphere so as to be always exposed to a controlled and/or defined gas atmosphere.

According to a preferred, isolation chamber 6 and isolation chamber 8 are connected such that, in use, bottles 2 are transferred from isolation chamber 6 directly into isolation chamber 8. In other words, bottles 2 are exposed to the second and third gas atmosphere so as to be always exposed to a controlled and/or defined gas atmosphere.

According to a preferred non-limiting embodiment, isolation chamber 8 and isolation chamber 13 are connected such that, in use, bottles 2 are transferred from isolation chamber 8 directly into isolation chamber 13. In other words, bottles 2 are exposed to the third and fourth gas atmosphere

so as to be always exposed to a controlled and/or defined gas atmosphere.

According to a preferred non-limiting embodiment, isolation chamber 13 is connected to isolation chamber 8. In particular, isolation chamber 13 is arranged downstream from isolation chamber 8 along advancement path Q.

According to a preferred non-limiting embodiment, each isolation chamber 4, 6, 8 and/or 13 is configured to be arranged on a horizontal surface (e.g. a floor of the production site) and comprises at least an upper wall distanced from the horizontal surface and a plurality of lateral walls connected to the respective upper wall so as to enclose a respective inner environment.

With particular reference to Figure 2, filter unit 17 comprises at least one filter element 35, in particular a high efficiency particulate air (HEPA) filter, for filtering the gas to be introduced into isolation chamber 4.

With particular reference to Figure 2, filter unit 18 comprises at least:

- 20 - a casing 38;
- an inlet duct 39 fluidically connected to suction device 19 and casing 38 and configured to allow the introduction of at least a portion of the extracted gas into casing 38;
- 25 - one or more filter elements 40, two in the example

embodiment shown, arranged within casing 38 and configured to filter the gas directed into casing 38;

- a first outlet duct 41 fluidically connected to casing 38 and isolation chamber 6 and configured to guide and/or
5 direct, in use, the first portion of the filtered gas into isolation chamber 6; and

- a second outlet duct 42 fluidically connected to casing 38 and isolation chamber 8 and configured to guide and/or direct, in use, the second portion of gas filtered
10 by filter element(s) 40 into isolation chamber 8.

According to a preferred non-limiting embodiment, filter unit 18 also comprises a third outlet duct 43 fluidically connected to casing 38 and isolation chamber 13 and configured to guide and/or direct, in use, the third
15 portion of the filtered gas into isolation chamber 13.

Preferentially but not necessarily, outlet conducts 41, 42 and 43 are mounted directly or indirectly to the respective upper wall of respectively isolation chamber 6, 8 and 13.

20 It should be noted that the term centralized filter unit 18 implies that filter element(s) 40 are not specifically associated to one respective isolation chamber 6, 8 or 13, but filter element(s) 40 filter the gas, which is then divided into the first and second (and third)
25 portions, so that first, second (and third) portion become

introduced into respectively isolation chamber 6 and 8 (and 13).

According to a preferred non-limiting embodiment, no further filter elements directly associated to isolation chamber 6, 8 and 13 are foreseen.

According to a preferred non-limiting embodiment, at least one filter element 40 is an ultra-low particle air (ULPA) filter.

With particular reference to Figure 2, suction device 19 comprises at least:

- one extraction conduct 44 fluidically connected to isolation chamber 4 and inlet conduct 39 and configured to guide and/or direct the extracted gas to and/or towards inlet conduct 39 and/or casing 38; and
- at least one suction element 45, such as a fan, configured to generate a suction force so as to at least extract the gas from isolation chamber 4 into extraction conduct 44 and to at least partially force the extracted gas through extraction conduct 44.

According to a preferred non-limiting embodiment, suction unit 44 is arranged within extraction conduct 44.

Preferentially but not necessarily, extraction conduct 44 is mounted onto the respective upper wall of isolation chamber 4.

With particular reference to Figure 2, filling plant 1

also comprises a flow dividing unit 46 fluidically connected to suction device 19 for receiving the extracted gas and configured to divide the extracted gas into at least a respective first portion and a respective second portion. In particular, flow dividing unit 46 is also fluidically connected to filter unit 18, in particular casing 38, even more particular inlet duct 39, and is configured to direct the first portion to, towards and/or into filter unit 18, in particular casing 38.

10 Preferentially but not necessarily, flow dividing unit 46 is configured to disperse the second portion into the environment.

Alternatively, flow dividing unit 46 could be configured to direct the second portion to further treatment devices and/or energy recovery devices.

With particular reference to Figure 2, filling plant 1 also comprises at least one conditioning unit 47 configured to condition the filtered gas and/or the gas to be filtered by filter unit 18. In particular, conditioning unit 47 is configured to at least partially condition the gas to be filtered prior to its filtration by filter unit 18.

According to the non-limiting embodiment shown, conditioning unit 47 is structurally separated from filter unit 18 and suction device 19. Alternatively, conditioning unit 47 could be structurally coupled and/or integrated to

filter unit 18 and/or suction device 19.

According to a preferred non-limiting embodiment, conditioning unit 47 is configured to control the temperature of the filtered gas and/or the gas to be filtered by filter
5 unit 18, in particular so that the temperature is below 36°C, even more particular that the temperature ranges between 20°C to 25°C and/or is substantially equal to the ambient temperature. In particular, in this way the possible growth of bacteria, microbes or similar is disfavored.

10 According to a preferred non-limiting embodiment, conditioning unit 47 is configured to mix at least the first portion of the extracted gas with a fresh gas, in particular fresh air, even more particular fresh ambient air, for controlling at least the temperature of the filtered gas
15 and/or the gas to be filtered by filter unit 18.

According to a preferred non-limiting embodiment, the fresh gas is gas, which has not been extracted from any one of isolation chambers 4, 6, 8 and 13.

Preferentially but not necessarily, conditioning unit
20 47 is configured such to control the ratios between the fresh air and the first portion of the extracted air such that the temperature of the filtered gas and/or the gas to be filtered by filter unit 18 to be below 36°C, in particular to range between 20°C to 25°C and/or to substantially equal the
25 ambient temperature.

In alternative or in addition, conditioning unit 47 could comprise a cooling unit, in particular a cooling unit of the known type, for controlling the temperature of the filtered gas and/or the gas to be filtered by filter unit 18 and/or the fresh gas and/or of at least the first portion of the extracted gas.

In particular, the temperature (of the first portion) of the extracted gas is a function of the pre-heating of preforms 3.

According to a preferred non-limiting embodiment, conditioning unit 47 is also configured to control the humidity of the gas to be filtered by filter unit 18 and/or the filtered gas.

According to a preferred non-limiting embodiment, filling plant 1 also comprises a flow control device (not specifically shown) configured to control at least the flow of the first portion and/or the second portion of the filtered gas within respectively isolation chambers 6 and 8.

Preferentially but not necessarily, the flow control device is also configured to control the flow of the third portion of the filtered gas within isolation chamber 13.

Preferentially but not necessarily, the flow control device is configured such:

- to control the flow of the first portion of the filtered gas from a respective top portion to a respective

bottom portion of isolation chamber 6; and/or

- to control the flow of the second portion of the filtered gas from a respective top portion to a respective bottom portion of isolation chamber 8; and/or

5 - to control the flow of the third portion of the filtered gas from a respective top portion to a respective bottom portion of isolation chamber 13; and/or

- to control a pressure within isolation chamber 6 to substantially equal the ambient pressure; and/or

10 - to control a positive pressure within isolation chamber 6 and/or 13 such that the positive pressure is larger than the ambient pressure, in particular being about 10 Pa to 26 Pa larger than the ambient pressure, even more particular being about 15 Pa to 20 Pa above the ambient
15 pressure; and/or

- to control a flow of gas from a respective bottom portion to a respective top portion of isolation chamber 4.

In particular, the positive pressure within isolation chamber 8 guarantees that a gas exchange between isolation chamber 6 and 8 can only occur from isolation chamber 8 to
20 isolation chamber 6.

In particular, the positive pressure within isolation chamber 13 guarantees that no external gases can enter isolation chamber 13.

25 Preferentially but not necessarily, the flow control

device comprises at least:

- at least one respective fan and/or blower associated to isolation chamber 6 configured to generate the flow of the first portion of the filtered gas from the respective top to the respective bottom portion of isolation chamber 6;
5 and/or

- at least one respective fan and/or blower associated to isolation chamber 8 and configured to generate the flow of the second portion of the filtered gas from the respective top to the respective bottom portion of isolation chamber 8;
10 and/or

- at least one respective fan and/or blower associated to isolation chamber 13 and configured to generate the flow of the third portion of the filtered gas from the respective top to the respective bottom portion of isolation chamber
15 13; and/or

- at least one respective fan and/or blower associated to isolation chamber 4 and configured to generate the flow from the respective bottom to the respective top portion of
20 isolation chamber 4.

It should be noted that a gas flow within isolation chamber 6 and/or 8 and/or 13 from the respective top to the respective bottom portion allows to ensure that contaminations present on the outer surfaces of bottles 2
25 are directed away from the respective pour openings of

bottles 2.

According to a preferred non-limiting embodiment, the respective interfaces between isolation chamber 4 and 5, and/or isolation chamber 6 and 8 are defined by the
5 respective flow directions of the respective gases and/or the respective gas pressures.

Preferentially but not necessarily, the flow control device further comprises:

- at least one respective aspirator associated to the
10 respective bottom portion of isolation chamber 6 and configured to create a suction force within isolation chamber 6, in particular in the area of the bottom portion of isolation chamber 6, so as to further support the flow of the first portion of the filtered gas from the respective
15 top to the respective bottom portion; and/or

- at least one respective aspirator associated to the respective bottom portion of isolation chamber 8 and configured to create a suction force within isolation chamber
20 isolation chamber 8, so as to further support the flow of the second portion of the filtered gas from the respective top to the respective bottom portion; and/or

- at least one respective aspirator associated to the respective bottom portion of isolation chamber 13 and
25 configured to create a suction force within isolation chamber

13, in particular in the area of the bottom portion of third isolation chamber 13, so as to further support the flow of the third portion of the filtered gas from the respective top to the respective bottom portion.

5 In use, filling plant 1 forms bottles 2 from preforms 3 and fills the obtained bottles 2 with the pourable product.

In particular, operation of filling plant 1 comprises at least the following steps:

- pre-heating preforms 3 within isolation chamber 4;
- 10 - filtering gas by filter unit 17 and introducing the filtered gas into isolation chamber 4;
- molding preforms 3 into bottles 2 within isolation chamber 6;
- filling bottles 2 within isolation chamber 8 with the
15 pourable product;
- extracting gas from isolation chamber 4 and feeding at least the first portion of the extracted gas into centralized filter unit 18, in particular casing 38;
- filtering at least the first portion of the extracted
20 gas by filter element(s) 40 for obtaining the filtered gas;
- directing at least the first portion of the filtered gas into isolation chamber 6 and at least the second portion of the filtered gas into isolation chamber 8, and preferentially but not necessarily the third portion of the
25 filtered gas into isolation chamber 13.

According to a preferred non-limiting embodiment, operation of filling plant 1 also comprises the step of closing bottles 2, during which closures are applied and fastened, in particular by the capping units, on bottles 2.

5 According to a preferred non-limiting embodiment, operation of filling plant 1 also comprises at least:

- a first step of advancing of preforms 3, during which preforms 3 are advanced along advancement path P, in particular by conveying device 16; and

10 - a second step of advancing of bottles 2, during which bottles 2 are advanced along advancement path Q, in particular by conveying device 16.

According to a preferred non-limiting embodiment, operation of filling plant 1 also comprises a step of
15 sterilization, during which preforms 3 are at least internally sterilized, in particular within sterilization unit 15. More specifically during the step of sterilization, a sterilization agent is introduced at least into preforms 3.

20 According to a preferred non-limiting embodiment, during the step of pre-heating, preforms 3 are heated by heating groups 21 during advancement along heating portion P1, in particular while being advanced by conveying device 16, even more particular by first conveyor 22.

25 According to a preferred non-limiting embodiment,

during the step of molding, preforms 3 are molded into bottles 2 during advancement of preforms 3 along molding portion P2, in particular while being advanced by second conveyor 27. In particular, during the step of molding,
5 preforms 3 are retained and molded within molding units 26.

Preferentially but not necessarily, during the step of molding, preforms 3 are molded into bottles 2 by means of blow or compression molding.

According to a preferred non-limiting embodiment,
10 during the step of filling, bottles 2 advance along filling portion Q2, in particular being advanced by third conveyor 29. In particular, during advancement along filling portion Q2, bottles 2 are retained and filled by the respective filling unit.

15 According to a preferred non-limiting embodiment, during the step of extracting gas, suction device 19 extracts the gas from isolation chamber 4 and directs the extracted gas towards filter unit 18. In particular, suction element 45 creates the suction force and at least partially forces
20 the extracted gas through extraction conduct 44.

According to a preferred non-limiting embodiment, operation of filling plant 1 also comprises a step of dividing, during which the extracted gas is divided, in particular by flow dividing unit 46, into the first portion
25 and the second portion of the extracted gas. In particular,

the first portion of the extracted gas is directed into and/or towards filter unit 18.

According to a preferred non-limiting embodiment, during the step of directing the filtered gas, the first and
5 second (and third) portions of the filtered gas are directed into respectively isolation chamber 6 and 8 (and 13) through respectively outlet conduct 41 and 42 (and 43).

According to a preferred non-limiting embodiment, operation of filling plant 1 also comprises a step of
10 conditioning, during which at least the filtered gas or the gas to be filtered by filter unit 18 is conditioned, in particular by conditioning unit 47.

Preferentially but not necessarily, during the step of conditioning, the temperature of the filtered gas and/or the
15 gas to be filtered by filter unit 18 is controlled, in particular so that the temperature is below 36°C, even more particular to range between 20°C to 25°C and/or to substantially equal the ambient temperature.

Preferentially but not necessarily, during the step of
20 conditioning, at least the first portion of the extracted gas is mixed with a fresh gas so as to control the temperature of the filtered gas and/or of the gas to be filtered by filter unit 18. In particular, the ratio between the fresh gas and the first portion of the extracted gas is such that
25 the temperature of the obtained gas mixture is below 36°C,

in particular ranging between 20°C to 25°C and/or to substantially equal the ambient temperature.

In alternative or in addition, during the step of conditioning, the temperature of the filtered gas and/or the gas to be filtered by filter unit 18 and/or the fresh gas and/or at least the first portion of the extracted gas is controlled by means of a cooling unit.

Preferentially but not necessarily, during the step of conditioning, the humidity of the gas to be filtered and/or the gas to be filtered by filter unit 18 is controlled.

According to a preferred non-limiting embodiment, operation of filling plant 1 also comprises the step of:

- controlling, in particular by means of the flow control device, the flow of the first portion of the filtered gas from the respective top to the respective bottom portion of isolation chamber 6; and/or

- controlling, in particular by means of the flow control device, the flow of the second portion of the filtered gas from the respective top portion to the respective bottom portion of isolation chamber 8; and/or

- controlling, in particular by means of the flow control device, the pressure within isolation chamber 6 to equal substantially the ambient pressure; and/or

- controlling, in particular by means of the flow control device, a positive pressure within isolation chamber

8 and/or isolation chamber 13 to be larger than the ambient pressure, in particular being about 10 Pa to 26 Pa, even more particular being about 15 Pa to 20 Pa above the ambient pressure.

5 Preferentially but not necessarily, operation of filling plant 1 also comprises the step of applying a suction force in the area of, in particular at, the respective bottom portion of isolation chamber 6 and/or 8 and/or 13.

 The advantages of filling plant 1 and the method of
10 operation of filling plant 1 according to the present invention will be clear from the foregoing description.

 In particular, filling plant 1 allows a more efficient use of gases, which are to be introduced into isolation chambers 4, 6, 8 and 13. The gas, which becomes introduced
15 into isolation chamber 4 is filtered by filter unit 17 and, thus, the extracted gas is purer than gas originating from the outer environment. By using some of the extracted gas to be filtered within filter unit 18 and being introduced into at least isolation chambers 6 and 8 it is possible to
20 increase the quality of the filtered gas.

 A further advantage resides in controlling the temperature of the filtered gas and/or the gas to be filtered by e.g. mixing the first portion of the extracted gas with a fresh gas so as to control the temperature. This is in
25 particular advantageous for obtaining a temperature below 36

°C so as to disfavor the growth of bacteria, microbes or similar.

An even further advantage resides in controlling a flow of the gases within isolation chambers 6, 8 and 13 from the
5 respective top to the respective bottom portions. In this way, possible contaminations present on the outer surfaces of preforms 3 and/or bottles 2 are distanced from the respective openings.

Clearly, changes may be made to filling plant 1 and/or
10 the method as described herein without, however, departing from the scope of protection as defined in the accompanying claims.

CLAIMS

1.- Filling plant (1) for producing bottles (2) from respective pre-forms (3) and filling the bottles (2) with a pourable product comprising:

5 - a pre-heating oven (5) at least partially arranged within a first isolation chamber (4) and configured to pre-heat the pre-forms (3) within the first isolation chamber (4);

10 - a first filter unit (17) associated to the first isolation chamber (4) and configured to filter a gas to be introduced into the first isolation chamber (4);

15 - a molding apparatus (7) being at least partially arranged within a second isolation chamber (6) and configured to mold the preforms (3) into the bottles (2) within the second isolation chamber (6);

 - a filling apparatus (9) being at least partially arranged within a third isolation chamber (8) and being configured to fill the bottles (2) within the third isolation chamber (8);

20 - a centralized filter unit (18) configured to filter at least a gas for obtaining a filtered gas and to feed at least a first portion of the filtered gas into the second isolation chamber (6) and at least a second portion of the filtered gas into the third isolation chamber (8); and

25 - a suction device (19) fluidically connected to the

first isolation chamber (4) and the centralized filter unit (18) and configured to extract gas from the first isolation chamber (4) and to direct at least a portion of the extracted gas to the centralized filter unit (18).

5 2.- Filling plant according to claim 1, wherein the centralized filter unit (18) comprises at least:

- a casing (38);

- an inlet duct (39) fluidically connected to the suction device (19) and the casing (38) and configured to
10 guide and/or direct at least a portion of the extracted gas into the casing (38);

- one or more filter elements (40) arranged within the casing (38) and configured to filter the gas directed into the casing (38) for obtaining the filtered gas;

15 - a first outlet duct (41) fluidically connected to the casing (38) and the second isolation chamber (6) and configured to direct and/or guide the first portion of the filtered gas into the second isolation chamber (6); and

20 - a second outlet duct (42) fluidically connected to the casing (38) and the third isolation chamber (8) and configured to direct and/or guide at least the second portion of the filtered gas, in use, into the third isolation chamber (8).

25 3.- Filling plant according to claim 1 or 2, further comprising a conditioning unit (47) configured to condition

the filtered gas or the gas to be filtered by the centralized filter unit (18).

4.- Filling plant according to claim 3, wherein the conditioning unit (47) is configured to mix at least a
5 portion of the extracted gas with a fresh gas for controlling the temperature of the filtered gas.

5.- Filling plant according to any one of the preceding claims, further comprising a flow control device configured to control at least the flow of the first portion of the
10 filtered gas within the second isolation chamber (6) and/or of the second portion of the filtered gas within the third isolation chamber (8).

6.- Filling plant according to claim 5, wherein the flow control device is configured such:

15 - to control the flow of the first portion and/or of the second portion of the filtered gas from a respective top portion to a respective bottom portion of respectively the second isolation chamber (6) and the third isolation chamber (8); and/or

20 - to control a pressure within the second isolation (6) chamber to substantially equal the ambient pressure;

- to control a positive pressure within the third isolation chamber (8) such to be larger than the ambient pressure.

25 7.- Filling plant according to claim 6, wherein the

flow control device comprises at least:

- one respective fan associate to the second isolation chamber configured to generate the flow of the first portion of the filtered gas from the respective top portion to the
5 respective bottom portion of the second isolation chamber (6); and/or

- one respective fan associated to the third isolation chamber and configured to generate the flow of the second portion of the filtered gas from the respective top portion
10 to the respective bottom portion of the third isolation chamber (8).

8.- Filling plant according to claim 6 or 7, wherein the flow control device comprises:

- at least one respective aspirator associated to the
15 respective bottom portion of the second isolation chamber (6) and configured to create a suction force within the second isolation chamber (6) in the area of the bottom portion of the second isolation chamber (6); and/or

- at least one respective aspirator associated to the
20 respective bottom portion of the third isolation chamber (8) and configured to create a suction force within the third isolation chamber (8) in the area of the bottom portion of the third isolation chamber (8).

9.- Filling plant according to any one of the preceding
25 claims, further comprising a conveying apparatus (16)

configured to advance the pre-forms (3) along a first advancement path (P) to, through and from the pre-heating oven (5) and to advance the bottles (2) along a second advancement path (Q) through the molding apparatus (7) and
5 to and through the filling apparatus (9).

10.- Filling plant according to any one of the preceding claims, wherein the centralized filter unit (18) comprises at least one ultra-low particle air filter (40).

11.- Method for producing bottles (2) from respective
10 pre-forms (3) and filling the bottles (2) with a pourable product comprising at least the steps of:

- pre-heating the preforms (3) within a first isolation chamber (4);

- introducing a gas filtered by a first filter unit
15 (17) associated to the first isolation chamber (4) into the first isolation chamber (4);

- molding the preforms (3) into the bottles (2) within a second isolation chamber (6);

- filling the bottles (2) within a third isolation
20 chamber (8) with the pourable product;

- extracting gas from the first isolation chamber (4) and feeding at least a portion of the extracted gas into the centralized filter unit (18);

- filtering at least the portion of the extracted gas
25 by at least one filter element (40) of the centralized filter

unit (18) for obtaining a filtered gas;

- directing at least a first portion of the filtered gas into the second isolation chamber (6) and at least a second portion of the filtered gas into the third isolation
5 chamber (8).

12.- The method according to claim 11, further comprising a step of conditioning during which the filtered gas or the gas to be filtered by the centralized filter unit (18) is conditioned.

10 13.- The method according to claim 12, wherein during the step of conditioning, at least the portion of the extracted air is mixed with fresh air so as to control the temperature of the filtered gas and/or of the gas to be filtered.

15 14.- The method according to any one of claims 11 to 13, further comprising the step of:

- controlling the flow of the first portion of the filtered gas from a top portion to a bottom portion of the second isolation chamber (6); and/or

20 - controlling the flow of the second portion of the filtered gas from a top portion to a bottom portion of the third isolation chamber (8); and/or

- controlling the pressure within the second isolation chamber (6) to equal substantially the ambient pressure;

25 and/or

- controlling a positive pressure within the third isolation chamber (8) to be larger than the ambient pressure.

15.- The method according to any one of claims 11 to 14, further comprising the step of applying a suction force
5 in the area of a respective bottom portion of the second isolation chamber (6) and/or the third isolation chamber (8).

FIG. 1

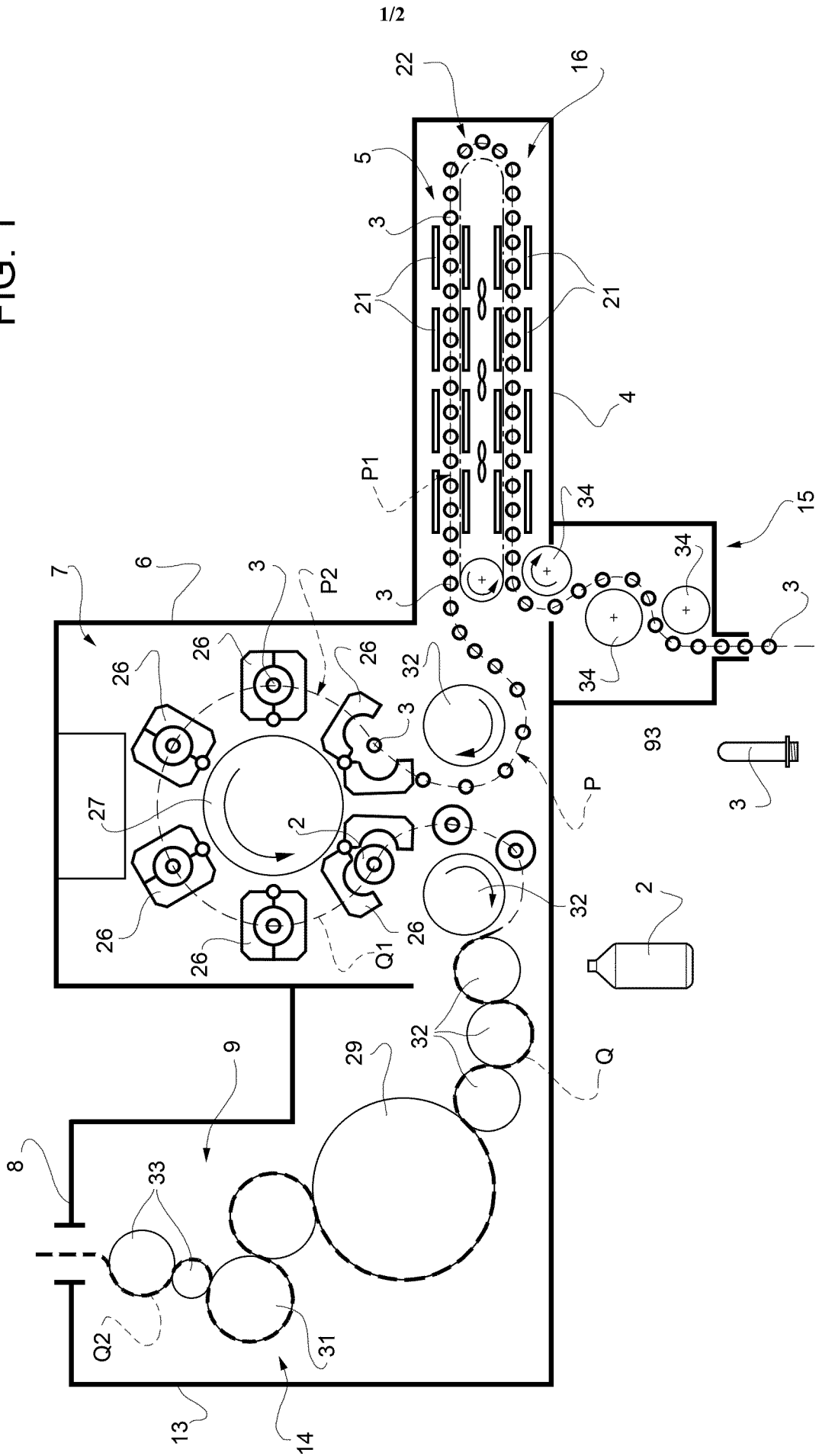

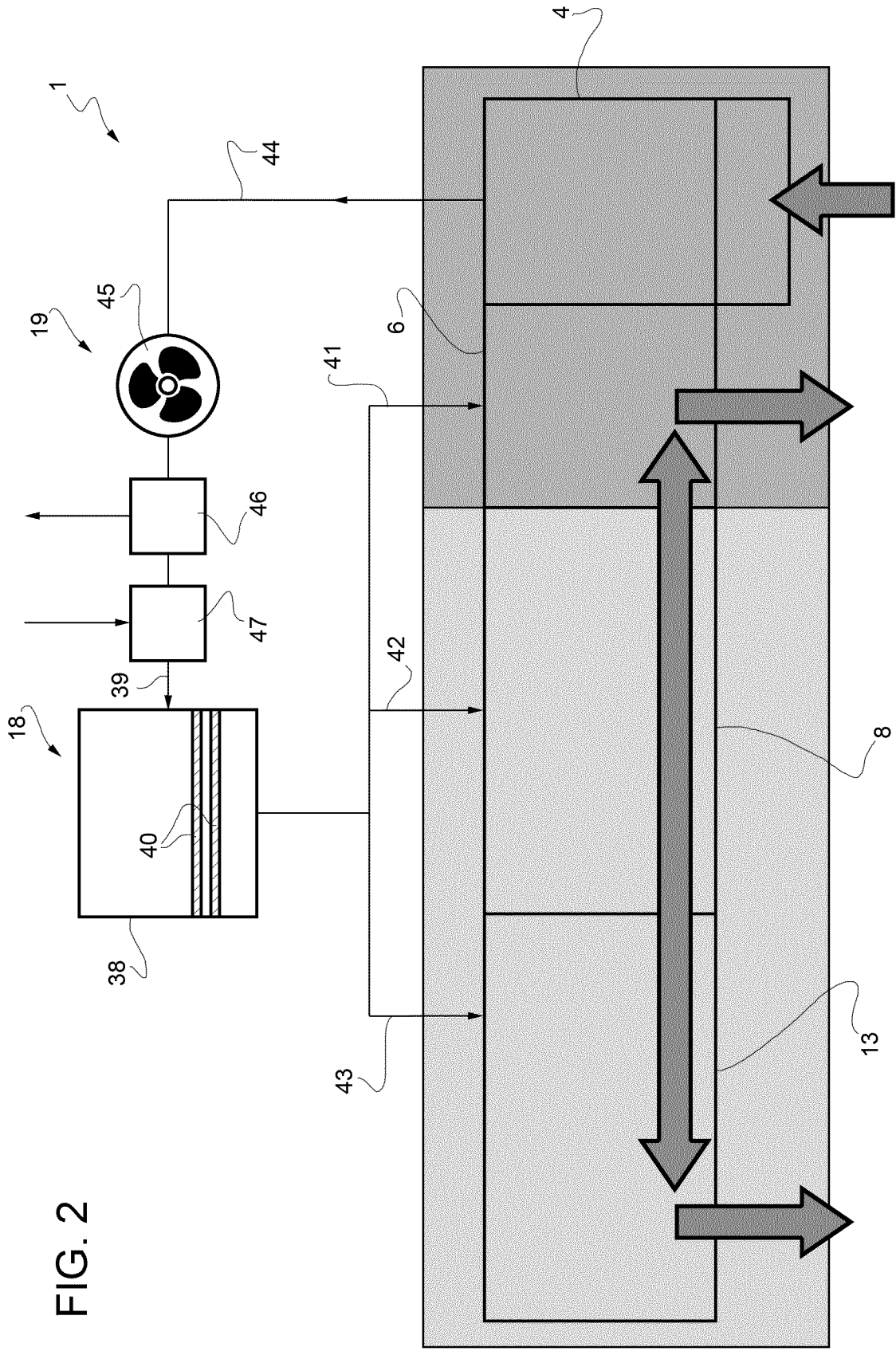

FIG. 2

INTERNATIONAL SEARCH REPORT

International application No
PCT/EP2019/082194

A. CLASSIFICATION OF SUBJECT MATTER
 INV. B29C49/46
 ADD. B29C49/06 B29C49/36 B29C49/64 B29L31/00

According to International Patent Classification (IPC) or to both national classification and IPC

B. FIELDS SEARCHED

Minimum documentation searched (classification system followed by classification symbols)
 B29C B29L

Documentation searched other than minimum documentation to the extent that such documents are included in the fields searched

Electronic data base consulted during the international search (name of data base and, where practicable, search terms used)
 EPO-Internal, WPI Data

C. DOCUMENTS CONSIDERED TO BE RELEVANT

Category*	Citation of document, with indication, where appropriate, of the relevant passages	Relevant to claim No.
A	US 2013/078327 A1 (ADRIANSENS ERIC [FR]) 28 March 2013 (2013-03-28) abstract; claim 1; figures 1-4 -----	1-15
A	US 2014/091499 A1 (BRUNNER ANDREAS [DE]) 3 April 2014 (2014-04-03) paragraph [0027] - paragraph [0030]; claim 1; figures 1-3 -----	1-15
A	EP 0 464 933 A2 (STORK AMSTERDAM [NL]) 8 January 1992 (1992-01-08) column 5, line 46 - column 6, line 16; claim 1; figures 1-3 -----	1-15
A	US 5 759 218 A (MARTIN BLAKE E [US] ET AL) 2 June 1998 (1998-06-02) abstract; claim 1; figures 1-6 -----	1-15
	-/--	

Further documents are listed in the continuation of Box C.

See patent family annex.

* Special categories of cited documents :

"A" document defining the general state of the art which is not considered to be of particular relevance

"E" earlier application or patent but published on or after the international filing date

"L" document which may throw doubts on priority claim(s) or which is cited to establish the publication date of another citation or other special reason (as specified)

"O" document referring to an oral disclosure, use, exhibition or other means

"P" document published prior to the international filing date but later than the priority date claimed

"T" later document published after the international filing date or priority date and not in conflict with the application but cited to understand the principle or theory underlying the invention

"X" document of particular relevance; the claimed invention cannot be considered novel or cannot be considered to involve an inventive step when the document is taken alone

"Y" document of particular relevance; the claimed invention cannot be considered to involve an inventive step when the document is combined with one or more other such documents, such combination being obvious to a person skilled in the art

"&" document member of the same patent family

Date of the actual completion of the international search	Date of mailing of the international search report
3 February 2020	11/02/2020

Name and mailing address of the ISA/ European Patent Office, P.B. 5818 Patentlaan 2 NL - 2280 HV Rijswijk Tel. (+31-70) 340-2040, Fax: (+31-70) 340-3016	Authorized officer Muller, Gérard
--	--

INTERNATIONAL SEARCH REPORT

International application No
PCT/EP2019/082194

C(Continuation). DOCUMENTS CONSIDERED TO BE RELEVANT		
Category*	Citation of document, with indication, where appropriate, of the relevant passages	Relevant to claim No.
A	US 2013/040009 A1 (LAUMER ROLAND [DE]) 14 February 2013 (2013-02-14) paragraph [0066] - paragraph [0085]; claim 1; figures 1-3 -----	1-15

INTERNATIONAL SEARCH REPORT

Information on patent family members

International application No PCT/EP2019/082194

Patent document cited in search report	Publication date	Patent family member(s)	Publication date	
US 2013078327	A1	28-03-2013	CN 102933370 A	13-02-2013
			EP 2580045 A1	17-04-2013
			FR 2961125 A1	16-12-2011
			JP 5694523 B2	01-04-2015
			JP 2013528130 A	08-07-2013
			US 2013078327 A1	28-03-2013
			WO 2011154294 A1	15-12-2011

US 2014091499	A1	03-04-2014	CN 103568302 A	12-02-2014
			DE 102012106916 A1	22-05-2014
			EP 2692506 A1	05-02-2014
			US 2014091499 A1	03-04-2014

EP 0464933	A2	08-01-1992	EP 0464933 A2	08-01-1992
			NL 9001504 A	03-02-1992

US 5759218	A	02-06-1998	NONE	

US 2013040009	A1	14-02-2013	CN 102950755 A	06-03-2013
			DE 102011052574 A1	14-02-2013
			EP 2556943 A2	13-02-2013
			JP 5969849 B2	17-08-2016
			JP 2013056530 A	28-03-2013
			US 2013040009 A1	14-02-2013
