

AMENDED

657103

AUSTRALIA
PATENTS ACT 1990



D90216
P/00/001
Section 29

18

PATENT REQUEST: STANDARD PATENT

WE, being the person identified below as the Applicant, request the grant of a patent to the person identified below as the Nominated Person, for an invention described in the accompanying standard complete specification.

Full application details follow:

- [71] Applicant PHILIPS ELECTRONICS N.V.
Groenewoudseweg 1,
5621 BA Eindhoven.
The Netherlands.
- [71] Nominated Person Address: PHILIPS ELECTRONICS N.V.
Groenewoudseweg 1,
5621 BA Eindhoven.
The Netherlands.
- [54] Invention Title: RECEIVER FOR A DIGITAL TRANSMISSION SYSTEM
- [72] Name(s) of actual Inventor (s) Alfred BAIER
- [74] Address for service in Australia: Patent & Trade Marks Division,
Philips Electronics Australia Limited
16th Floor, The Philips Building,
15 Blue Street, North Sydney.
N.S.W. 2060.

Attorney Code PH

[BASIC CONVENTION APPLICATION(S) DETAILS

[60] Application No.	[33] Country	Country Code	32] Date of Appl.
P 4038251.6	GERMANY	DE	30.11.90

Drawing Number recommended to accompany the Abstract: FIG.1

For and on behalf of
PHILIPS ELECTRONICS N.V.

P. Mackenzie
P.W. Mackenzie (Attorney)

16-11-90
Date

AUSTRALIA

PATENTS ACT 1990

NOTICE OF ENTITLEMENT

(TO BE FILED BEFORE ACCEPTANCE)

WE PHILIPS ELECTRONICS (formerly named N.V. PHILIPS'
GLOEILAMPENFABRIEKEN),

of Groenewoudseweg 1, Eindhoven, The Netherlands being the
applicant in respect of Application No. 88270/91

state the following:-

1. The person nominated for the grant of the patent has entitlement from the actual inventor by virtue of a mesne assignment.
2. The person nominated for the grant of the patent has entitlement from the applicant of the basic application listed on the patent request form by virtue of assignment.
3. The basic application listed on the request form is the first application made in a convention country in respect of the invention.

Dated this *2nd* Day of *December* 1994

For and on behalf of
PHILIPS ELECTRONICS N.V.

P. Mackenzie
P.W. Mackenzie
Attorney



AU9188270

(12) PATENT ABRIDGMENT (11) Document No. AU-B-88270/91
(19) AUSTRALIAN PATENT OFFICE (10) Acceptance No. 657103

- (54) Title
RECEIVER FOR A DIGITAL TRANSMISSION SYSTEM
- International Patent Classification(s)
(51)⁵ H04L 025/03 H03M 013/12
- (21) Application No. : 88270/91 (22) Application Date : 29.11.91
- (30) Priority Data
- (31) Number (32) Date (33) Country
4038251 30.11.90 DE GERMANY
- (43) Publication Date : 04.06.92
- (44) Publication Date of Accepted Application : 02.03.95
- (71) Applicant(s)
PHILIPS ELECTRONICS N.V.
- (72) Inventor(s)
ALFRED BAIER
- (74) Attorney or Agent
PHILIPS ELECTRONICS AUSTRALIA LIMITED , P.O. BOX 1138, NORTH SYDNEY N.S.W. 2059
- (56) Prior Art Documents
US 5119400
US 7823346
US 4748626
- (57) Claim

1. Receiver for a digital transmission system comprising a transmit channel having a storage depth n with an analog signal processing section, which receiver comprises an analog-to-digital converter and an equalizer which has a digital signal processing section that includes a memory means with a register for storing state transitions (S_i, S_{i+1}), characterized in that the registers of the memory means all comprise $2^{n'}$ memory locations, with $1 \leq n' < n$, in that the memory means comprises a memory path register in which at each discrete instant (i) at least n previous bits ($b_{i-1}, \dots, b_{i-n'}, b_{i-n'-1}, \dots, b_{i-n}, \dots$) are stored commencing at an appropriate first previous bit (b_{i-1}) for $2^{n'}$ states.

657103

PHD90216

AUSTRALIA

PATENTS ACT 1990

COMPLETE SPECIFICATION
FOR A STANDARD PATENT

O R I G I N A L

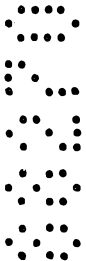

Name of Applicant: Philips Electronics N.V.
~~N. V. PHILIPS' GLOEILAMPENFABRIEKEN~~

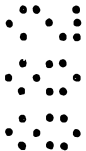

Actual Inventors: ALFRED BAIER



Address for Service: PATENT AND TRADE MARKS DIVISION,
PHILIPS INDUSTRIES HOLDINGS LIMITED
15 BLUE STREET,
NORTH SYDNEY, NSW 2060



Invention Title: "RECEIVER FOR A DIGITAL TRANSMISSION
SYSTEM"

The following statement is a full description of this invention including the best method of performing it known to us.

Receiver for a digital transmission system.

The invention relates to a receiver for a digital transmission system comprising a transmit channel having a storage depth n with an analog signal processing section, which receiver comprises an analog-to-digital converter and an equalizer which has a digital signal processing section that includes a memory means
5 with a register for storing state transitions.

Such receivers are necessary for the future pan-European mobile radio system (GSM system). In this mobile radio system speech signals are transmitted in digitized form together with other digital signals according to a time-division multiple-access method. These data are transmitted by a transmitter of the mobile radio system
10 via a suitable modulation. As a result of reflections and multipath propagation on the transmit path the transmitted signal reaches the receiver in various superposed signal portions presenting different delays and phase shifts. This distorts the signal transmitted by the transmitter. These distortions cause the bits contained in the received signal to be affected by preceding bits (intersymbol interference). Between transmitter and
15 receiver there is a transmit channel having a storage depth n , where n is an integer and denotes the number of interfering neighbouring bits. For recovering the original data content of the signal, it is necessary to equalize the received signal.

DE-A 39 11 999 discloses a receiver for a digital transmission system of the type mentioned in the preamble. The receiver comprises an equalizer for forming binary estimates on the basis of a sequence of signal sample values. Each sample value can be assigned with time to a transmitted bit having the binary "0" or "1" value and depends on this bit and also on n immediately preceding bits. The equalization is then
20 performed with the aid of the so-called Viterbi algorithm. According to this algorithm
25 2^n states and a probability parameter for each transition from one state to a time-

consecutive state are assigned to each sample value. By stringing the state transitions together, paths are formed and an overall probability parameter is formed from all the probability parameters of one path. From all the paths leading to one state only the path having the smallest overall probability is taken into consideration. A transition from a state determined by the bits $b_{i-1} \dots b_{i-n}$ at a discrete instant i with a binary value $b_{i-n} = 0$ (= "0"-transition) to a next state determined by the bits $b_i \dots b_{i-n+1}$ at an instant $i+1$ determines so-called "0"-paths and with a binary value $b_{i-n} = 1$ (= "1"-transition) so-called "1"-paths. From the overall probability parameters of all the possible "0"-paths and from the overall probability parameters of all the possible "1"-paths, always the smallest overall probability parameter is selected. The path defined by the bit sequence b_i, \dots, b_{i-n} for $b_{i-n} = 0$ or $b_{i-n} = 1$ respectively, and having the smallest overall probability parameter of all the 2^n possible "0"-paths or "1"-paths characterizes the minimum "0"-path or minimum "1"-path respectively. The binary number, *i.e.* zero or one, assigned to the smaller of the two selected overall probability parameters denotes the estimate, while reliability information for this estimate is formed on the basis of the two selected overall probability parameters. The reliability information is estimated in a decoder following the equalizer in the system. The costs of realizing the equalizer are in a first approximation proportional to the number of states 2^n , *i.e.* it exponentially increases with the storage depth n of the transmit channel.

It is an object of the invention to provide a receiver of the type mentioned in the preamble which presents reduced manufacturing costs.

This object is achieved with a receiver of the type mentioned in the preamble in that the registers of the memory means all comprise $2^{n'}$ memory locations, with $1 \leq n' < n$, in that the memory means comprises a memory path register in which at each discrete instant at least n previous bits are stored commencing at an appropriate first previous bit for $2^{n'}$ states.

A signal received by the receiver has an analog signal behaviour as a result of the superpositioning of neighbouring bits corresponding to the storage depth n of the transmit channel. Consequently, the received signal is first sampled in the analog signal processing section. The sample values thus obtained are converted by the analog-to-digital converter and further processed by the equalizer. The equalizer of the

receiver is then based on a reduced state model with $2^{n'}$ states, where $1 \leq n' < n$. With the reduced-state equalizer only n' bits are still determined directly by a state transition. The remaining $n-n'$ bits appear from each memory path leading to the respective state, which path is stored in the memory path register. This is advantageous in that only $2^{n'}$ states are to be processed at each sampling instant as against an equalizer that takes all 2^n states into consideration. In a coarse approximation this achieves a cost reduction by the factor of $2^n/2^{n'}$.

A low-cost estimate for a bit is formed in that the equalizer comprises a control and arithmetic logic which forms probability parameters for a state transition on the basis of the $n'+1$ bits featuring this state transition and stored in the memory means and on the basis of the $n-n'$ bits of the memory path register, which control and arithmetic logic forms a minimum "0"-path and a minimum "1"-path respectively, on the basis of the bit sequences of all the $2^{n'}$ possible "0"-paths and "1"-paths and forms appropriate overall probability parameters, which control and arithmetic logic decides that the binary value assigned to the smaller of the two considered overall probability parameters is an estimate for the bit $b_{i-n'}$ and which control and arithmetic logic forms reliability information for this estimate on the basis of the two considered overall probability parameters. During this operation the control and arithmetic logic provides the whole control, the formation of the probability parameters and the overall probability parameters as well as the implementation of the equalization based on the Viterbi method as is described, for example, in DE-A 39 11 999.

In an embodiment the memory path register has a storage depth of M previous bits, with $M \geq n$, in that at instant i an estimate \hat{b}_{i-N} is taken from the minimum "0"-path of the memory path register for the bit b_{i-N} with $n' < N < M$ if the overall probability parameter of the minimum "0"-path is smaller than the overall probability parameter of the minimum "1"-path, otherwise from the minimum "1"-path, while a correct assignment of the estimate \hat{b}_{i-N} to the reliability information $(P(\hat{b}_{i-n'}))$ is obtained by delaying the reliability information $(P(\hat{b}_{i-n'}))$ by $N-n'$ time intervals. The estimates recovered from memory locations further back in time of the memory path, present a greater reliability compared with the estimates recovered from a "shorter" memory path register.



In a further embodiment the memory path register has a storage depth of M previous bits, with $M \geq n$, while at instant i reliability information is formed for the bit b_{i-N} with $n' < N \leq M$ and this reliability information is substituted by a predeterminable substitute value if either only "0"-paths or "1"-paths exist at instant i .

5 This achieves that the equalizer continues to operate with a suitable substitute value in the cases where no exact reliability information can be derived for the bit b_{i-N} .

In an embodiment the reliability information is formed by the ratio between the probability values of the two selected paths. The ratio between the two probability values then expresses how many times an estimate is more probable than the complement value of this estimate.

10

In a further embodiment the squared distance of the probability of the transition between two states is used as a metric of a probability parameter and the metric found for a state transition is added to the overall metric determined so far to form the overall metric of an overall probability parameter. Use is then made of the possibility that instead of the probability parameters, so-called metrics can be used which result from the negative logarithm of each probability parameter. This is advantageous in that the metrics only need to be added together to calculate an overall probability, whereas the individual probability parameters are to be multiplied.

15

In an embodiment the overall metric of the "0"-paths is subtracted from the overall metric of the "1"-paths, the sign of the difference denoting the estimate and the absolute difference value denoting the reliability information assigned to the estimate. A positive sign then indicates that "1" is more probable as an estimate than "0".

20

In an embodiment the reliability information is corrected by a value depending on a determined noise power. With the reliability information thus weighted, it will then be possible to use for the further processing of the received signal the very data elements of the received signal that form an optimum security against an erroneous estimate.

25

In an embodiment the information signals to be transmitted are encoded into bits by means of a convolutional encoder at the transmitter end while at the receiver end a convolutional decoder is arranged as a decoder after the equalizer, which

30

5 decoder, when decoding, processes not only the estimated bits, but also the reliability information assigned to these estimated bits. In this manner the probability is enhanced that also the actually transmitted data sequence is obtained after decoding, because the decoder also comprises the information as to which individual bits it may "trust" more and which bits it may "trust" less.

In the following the invention will be further explained with reference to the exemplary embodiments shown in the drawing Figures, in which:

10

Fig. 1 shows a block diagram of a digital transmission system;

Figs. 2 to 4 show state diagrams for an equalizer; and

Fig. 5 shows a further exemplary embodiment for a digital transmission system.

15

Fig. 1 shows a radio transmission system in which the information signals to be transmitted are radiated in the form of a binary signal b over a transmitter 1. Between the transmitter 1 and a receiver formed by a signal receiver 2, a sample-and-hold element 21, an analog-to-digital converter 22 and an equalizer 3, a transmit channel 11 is arranged as a radio link denoted by an arrow. The receiver 2 is followed in the system by a sample-and-hold element 21 as well as an analog-to-digital converter 22. The signals at the digital output of the analog-to-digital converter 22 are applied to the equalizer 3. The equalizer 3 comprises a digital signal processing section that includes a signal estimator 32, a control circuit 34, a transversal filter 31, a memory means 33 also referenced memory module in the following, as well as a control and arithmetic logic 35. The memory means 33 comprises registers 331, 332, 333 as well as a memory path register 334. The control and arithmetic logic 35 generates an estimate \hat{b} as well as reliability information (\hat{P}_b) for this estimate \hat{b} .

30

The transmitted signal is distorted on the radio link situated between the transmitter 1 and the receiver 2 as the result of multipath propagation due to reflections and due to superimposed noise and further disturbing signals, as is shown in Fig. 1 by

the dashed arrows of the radio link. Consequently, a bit b_i of the binary signal b transmitted at a discrete instant i is superimposed by delayed signal portions of previously transmitted bits b_{i-1} , b_{i-2} , This superpositioning corresponds to a signal distortion. Consequently, the signal received for a transmitted bit can no longer be unequivocally assigned to a low or high level. The transmit channel 11 has thus a storage depth n , where n is the number of interfering neighbouring bits. The storage depth n can also be defined as a quotient of the channel impulse response length of the transmit channel 11 and a bit duration of the received signal, minus 1, while the largest integer from this result is to be taken. As a result of these superpositionings the signal received from receiver 2 has an analog signal variation which cannot be assigned to the originally transmitted bit without equalization. The signal received from the receiver 2 is first sampled by the sample-and-hold element 21 at equidistant instants. The analog sample values thus obtained are converted into digital sample values z to be further processed by the analog-to-digital converter 22.

The influence of already transmitted bits depends on the delay of the signal portions arriving at the receiver. After a specific period of time depending on the characteristic feature of the transmit channel, the influence is no longer essential and therefore need not be taken into consideration for an equalization. As a rule, the delay is expressed as a number of bits transmitted in this period of time. For the equalizer 3 it holds that each sample value z_i that can be assigned to a bit b_i transmitted at an instant i depends on the bit b_i that can be assigned to this sample value and on n bits b_{i-1} , b_{i-2} , ..., b_{i-n} that have preceded this bit.

The equalization of the signal z of the output of the analog-to-digital converter 22 is based on a channel model approximately describing the dispersive transmit channel 11 of the radio transmission system by means of a linear finite transversal filter. For such a channel model the transmission properties of the transmit channel are simulated by means of filter coefficients $h_0 \dots h_n$. At the receiver end efforts are therefore made with this specific channel model to simulate the distortions occurring on the transmit path by means of the transversal filter 31, which distortions are caused by the linear combinations comprising a memory. The simulation of the transmit path is attained by accordingly adjusting the filter coefficients h_0, \dots, h_n , for

$n=3$. The filter coefficients h_0, \dots, h_3 may then be derived from the sample values of an estimated impulse response of the transmit channel. For example, a so-called training sequence may therefore be used, which comprises a bit sequence known to both the transmitter 1 and the receiver 2. With each reception of the training sequence the filter coefficients h_0, \dots, h_3 are adjusted so that after the transversal filter 31 has been passed through the transmit channel having the fewest errors is simulated. This is known, for example, from DE 40 01 592 A1.

In the exemplary embodiment represented in Fig. 1 the circuit arrangement for forming the filter coefficients is not shown for clarity. The equalizer shown in Fig. 1 is based on the so-called Viterbi method as described, for example, in European Patent Application EP 0 294 116 A2. The Viterbi method as such is known, for example, from the paper entitled "The Viterbi algorithm" by G. David Forney Jr., Proceedings of the IEEE, Vol. 61, No. 3, March 1973. According to this algorithm a so-called soft decision decoding for the data elements to be decoded of an encoded data sequence requires reliability information for the data sequence to be decoded. The reliability information is a probability parameter denoting with what probability the data elements to be decoded correspond to the transmitted data elements. As a rule, a state diagram is used for representing the Viterbi method, as is done in the Figs. 2 to 4. Instead of probability parameters also so-called metrics may be used, while the metric can be calculated from the negative logarithm of each probability parameter. This is advantageous, for example, in that the metrics now only need to be added together for calculating an overall probability, whereas the individual probability parameters are to be multiplied.

For calculating the transition probability from one state to a next state, the individual binary values of the bits b_i, \dots, b_{i-n} of a state are used as input parameters of the transversal filter 31. The output value of the transversal filter 31 produces as a first approximate, while discarding disturbances caused by a disturbing or noise signal etc. contained in the input signal, the value which the sample should adopt when the bit sequence b_i, \dots, b_{i-n} used as an input parameter is transmitted or received over the radio link. By comparing the output value of the transversal filter 31 with the actual sample value, the most probably transmitted bit sequence may thus be found.

A large transition probability from one state to a next state does not yet provide sufficient guarantee for the correctness of this transition, because a state transition that has actually not taken place may accidentally appear as the most probable transition due to brief disturbances or signal noise. More correct estimates of the state transitions are achieved by taking the whole signal variation produced so far into consideration by means of a probability examination of all the state transitions leading to one of the 2^n states at the instant concerned. The costs of realising such an equalizer are approximately proportional to the number of states 2^n , *i.e.* they rise exponentially with the storage depth n of the transmit channel.

Alternatively, the equalizer 3 shown in Fig. 1 is based on a state model with $2^{n'}$ states, where $1 < n' < n$. In the exemplary embodiment shown in Fig. 1, $n=3$ and $n'=2$. This produces a reduction of the number of states $2^{n'}=4$ as against the equalizer having the full number of states $2^n=8$. The difference from the equalizer with a full number of states 2^n consists of the fact that in the equalizer with a reduced number of states $2^{n'}$ only the n' bits $b_i, \dots, b_{i-n'}$ are determined direct by a state transition S_i, S_{i+1} . The remaining $n-n'$ bits $b_{i-n-1}, \dots, b_{i-n}$ emerge from a memory path leading to the state S_i , which is stored in a memory path register 334 of the memory module 33. Therefore, in contradistinction to the soft decision equalizer with a full number of states, the memory path register 334 is to be used for the soft decision equalizer with a reduced number of states. In this register 334 at least n previous bits $b_{i-1}, \dots, b_{i-n'}, b_{i-n'-1}, \dots, b_{i-n}$... are to be stored at each instant i from the bit b_{i-1} for all $2^{n'}$ states S_i . The bits $b_{i-1}, \dots, b_{i-n'}$ need not necessarily be stored in the memory path register 334 because they are identical with the state bits of the state S_i concerned.

For forming the metric in the exemplary embodiment shown in Fig. 1 an output value \hat{z}_i of the transversal filter 31 is subtracted from the digital sample value z_i in a signal estimator 32 and squared. In this manner a squared distance is formed. The probability that the received sample value has originated from the bit sequence used as an input parameter is greater as this squared distance is smaller. Due to the linear combination of the n last digits, however, an optimum estimate cannot be formed until all n bits have been received.

The estimate \hat{b}_i assigned to the sample value z_i is assigned in time to the state transitions from one state S_i to the states S_{i+1} at the instant $i+1$.

For implementing the method, the memory module 33 shown in the
 5 exemplary embodiment represented in Fig. 1 comprises metric registers denoted 331, 332, 333 as well as the memory path register 334. Each register comprises 2^n memory locations, the three bits $a_1 \dots a_3$ being used for addressing the columns as will be described hereinbelow. Each memory location of the registers is then assigned a single address $a_1 \dots a_3$. The overall metric assigned to one state is stored in the first register 331. In the second metric register 332 a new overall metric is stored at the address a_1
 10 $\dots a_3$, which metric has been produced by a "0" transition, *i.e.* so-called "0"-paths, whereas in the third register 333 an overall metric is stored produced by a "1"-transition, *i.e.* so-called "1"-paths. With a state transition from a state S_i determined by the bits b_{i-1}, \dots, b_{i-n} at an instant i with a bit $b_{i-n} = 0$ (= "0"-transition) to a next state S_{i+1} determined by the bits $b_i \dots b_{i-n+1}$ at an instant $i+1$, so-called "0"-paths are determined and, similarly, so-called "1"-paths with a digit $b_{i-n} = 1$ (= "1"-transition). Furthermore, at least n previous bits are stored in the memory path register 334 for all 2^n , *i.e.* four, states in the exemplary embodiment shown in Fig. 1. When a memory location is driven the control circuit 34 simultaneously applies the relevant address $a_1,$
 15 \dots, a_3 to the transversal filter 31 as an input parameter. For each formed address the first input parameter is available at the control circuit as a first binary number, for example, a "0". From this value \hat{z} of the transversal filter 31 thus obtained and the sample value z the squared distance $(\hat{z}-z)^2$ is formed in the estimator 32. From this squared distance and from the overall metric stored in the first metric register 331 at the appropriate address a new overall metric is formed which is stored in the second metric register 332 at the appropriate address. In similar fashion the second binary number, for example, a "1" is available for the first input parameter and the overall metric obtained in this fashion is stored in the third metric register 333. Once the control circuit 34 has passed through all the address combinations, and all the contents
 20 of the second and third path registers 332, 333 have been calculated once again, the smallest values are selected from all the new overall metrics of the second and third
 25
 30

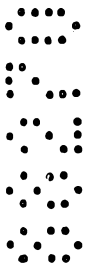

metric registers 332, 333. These two values are subtracted from each other. The sign of the difference finally denotes the estimate \hat{b} and the absolute difference value the desired reliability information $P(\hat{b})$ for the bit b_{i-n} . Once the estimate \hat{b} has been determined, an update takes place, *i.e.* the relocation of the first to third path registers 331, ..., 333 and of the metrics stored in the memory path register 334.

For this operation the control and arithmetic logic 35 also denoted equalizer logic provides the overall control, the formation of the overall metrics as well as the implementation of the Viterbi algorithm. This is effected in a fashion known, for example, from DE-A 39 11 999. Subsequently, the arrival of a new sample value is awaited and the associated new estimate and the associated reliability information is formed in the manner already described.

Thus, the following steps are executed with the exemplary embodiment shown in Fig. 1:

1. Fetch $L_i(b_{i-1}, \dots, b_{i-n}) = L_i(S_i)$ from register 331
2. Fetch $(b_{i-n-1}, \dots, b_{i-n})$ from register 334 for the path $(b_{i-1}, \dots, b_{i-n})$
3. $L_{i+1}(S_i, S_{i+1}) = L_{i+1}(b_i, b_{i-1}, \dots, b_{i-n}) = L_i(S_i) + |z_i - \hat{z}_i|^2$, where $\hat{z}_i = \sum_{v=0}^n y_{i-v} \times h_v$ with $y_{i-v} \in (+1, -1)$
4. If $b_{i-n} = 0$, store $L_{i+1}(S_i, S_{i+1})$ in register 332 at the address $(b_i, b_{i-1}, \dots, b_{i-n'+1})$
5. If $b_{i-n} = 1$, store $L_{i+1}(S_i, S_{i+1})$ in register 333 at the address $(b_i, b_{i-1}, \dots, b_{i-n'+1})$
6. Search for minimum of the "0"-paths L_{i+1} from register 332
7. Search for minimum of the "1"-metrics L_{i+1} from register 333
8. Determine $P(\hat{b}_{i-n})$ and \hat{b}_{i-n} from minimums (6. and 7.)
9. Update registers 331 and 334.

Here L denotes the overall metrics of the paths characterized by the individual state transitions.

The state diagram shown in Fig. 2 is a diagram having columns of 2^n nodes. Each node represents one of the combinations that can be produced from n bits. Each column is assigned to a specific sampling instant $i-3, i-2, i-1, i, i+1$. The

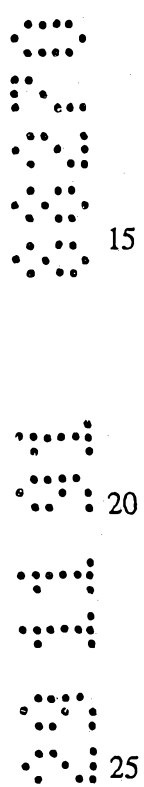

individual binary values 000...111 that can be assigned to a node are denoted states. A state always corresponds to the fact that the n last digital sample values received at an instant i may have been assigned to a bit sequence that may have been transmitted.

When a new sample value is received both the "0" bit and the "1" bit may be assigned to it. A bit sequence 010 results in a bit sequence 0010 when the most recent sample value is assigned to the binary value 0. Since the oldest sample value does not affect the equalization because a new sample value is received, this new binary value is omitted. In the state diagram shown in Fig. 2 all the possible transitions are denoted by arrows. For example, the node x features a state of the bit sequence 010 at instant i.

Via a 0 the node y is arrived at, to which the state $S_{i+1} = 001$ is assigned at the instant $i+1$; via a "1"-transition, node z is arrived at, to which the state $S_i = 101$ is assigned at the instant $i+1$. A path is formed by stringing related transitions together. This path has the same meaning as the reconstructed bit sequence b_i, \dots, b_{i-n} . The state diagram shown in Fig. 2 based on the prior-art state model from DE-A 39 11 999 clarifies that the manufacturing costs for an equalization based on a number of states 2^n are high.

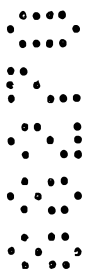

15

Fig. 3 shows a state diagram for the equalizer shown in Fig. 1, which diagram is based on a state model with only $2^{n'}$ states, with $2^{n'} = 4$. If the state diagram represented in Fig. 2 is compared with the state diagram represented in Fig. 3, the saving on manufacturing costs relative to a state model with 2^n states will become apparent. Furthermore, in the state diagram represented in Fig. 3 (state trellis) all the possible paths are featured. Generally, so-called "0"-paths are determined by a state transition from a state S_i , determined by the bits $b_{i-1} \dots b_{i-n}$, at an instant i having a bit $b_{i-n} = 0$ (= "0"-transition) to a time-consecutive state S_{i+1} , determined by the bits $b_i \dots b_{i-n+1}$ at an instant $i+1$, and, similarly, so-called "1"-paths with a bit $b_{i-n} = 1$ (= "1"-transition). In the state trellis represented in Fig. 3 $n'=2$ was used in accordance with the examples already used for the description of Fig. 1. Thus, in the state trellis represented in Fig. 3 the state transition S_i, S_{i+1} is characterized by the bits b_i, b_{i-1}, b_{i-2} . The bit b_{i-3} characterizing the state S_{i+1} may be fetched from the memory path register at the instant i from the location $i-3$.

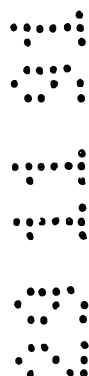

25

Fig. 4 shows a state diagram in which only the paths are shown for which all transitions from the instant $i-2$ to the instant $i-1$ were "0"-transitions, i.e. for

30

which always the binary number "0" was assigned to the bit $b_{i,2}$. This corresponds to the "0"-paths for a state transition S_i, S_{i+1} . For the values of the exemplary embodiment of $n = 3, n' = 2$ the probability parameters are computed on the basis of $2^n = 4$ states 11, 10, 01, 00. Only the $n'+1 = 3$ bits b_i, b_{i-1}, b_{i-2} are then determined direct by the state transition S_i, S_{i+1} , whereas the remaining $n-n' = 1$ bit b_{i-3} results from the memory path leading to the state S_i . For this reason, in contradistinction to the so-called soft decision equalizer with a full number of states, a memory path register which stores at each state i for all 2^n states the memory path $b_{i-1}, \dots, b_{i-n}, b_{i-n-1}, \dots, b_{i-n}, \dots$ over a length of at least n bits reckoned from the bit b_{i-1} is explicitly to be updated. The bits b_{i-1}, \dots, b_{i-n} may also be omitted for this purpose because they are actually identical with the bits of the state S_i concerned.

Fig. 5 shows a state trellis in which only all the "1"-paths for a state transition S_i, S_{i+1} are shown. Here the binary number "1" is assigned to each bit $b_{i,2}$. For forming the estimate and the reliability information the smallest overall metric is determined from all the overall metrics of the states resulting from a "0"-transition and from all the overall metrics resulting from a "1"-transition, *i.e.* the path having the smallest overall metric is selected. In the state diagrams shown in Figs. 4 and 5. These paths then form the minimum "0" or minimum "1"-path respectively. Each of the two selected minimum overall metrics expresses the probability with which each selected path in the ideal case can be assigned to the estimate $b_{i,n} = 0$ or the estimate $b_{i,n} = 1$. These probability values can be computed from the overall metrics. In the last step the two overall probability parameters available for each state S_{i+1} are compared with each other and the smaller overall probability parameter is assigned to each state S_{i+1} as the new probability parameter. By means of inverse metrics it is also possible to form maximums instead of minimums.

Fig. 6 shows a further exemplary embodiment of a digital transmission system. An information signal x to be transmitted is first applied to a convolution encoder 5. The convolution encoder 5 produces a binary signal b which is transmitted over a dispersive transmit channel by a transmitter 1. At the receiver end there is receiver 2 which produces a sample signal z . This sample signal z is applied to an equalizer 3. The equalizer produces estimates \hat{b} as well as appropriate reliability

information $\hat{P}(b)$. The estimates as well as the reliability information are applied to a decoder 6 which decodes herefrom a sequence of \hat{x} . A decoder operating according to the Viterbi process is used for this decoding.

- 5 For the Viterbi decoding the received encoded signal sequence is compared with any valid code sequence the encoder 5 might have produced. For the Viterbi decoder the number of bits are used in which the equalized data sequence is distinguished from the individual code elements of the code storage. When multiplying a metric obtained in this fashion by the reliability information an estimate is obtained of
- 10 a data sequence to be decoded. In this fashion the probability is enhanced that the originally transmitted data sequence is really obtained after decoding. The decoder 6 then uses not only the signal redundance for decoding purposes but also information about which individual bits of the data sequence to be decoded it may "trust" more or "trust" less.

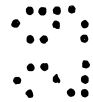
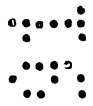
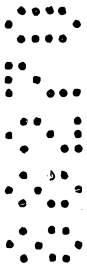

THE CLAIMS DEFINING THE INVENTION ARE AS FOLLOWS:

1. Receiver for a digital transmission system comprising a transmit channel having
 5 a storage depth n with an analog signal processing section, which receiver comprises an analog-to-digital converter and an equalizer which has a digital signal processing section that includes a memory means with a register for storing state transitions (S_i, S_{i+1}) , characterized in that the registers of the memory means all comprise $2^{n'}$ memory locations, with $1 \leq n' < n$, in that the memory means comprises a memory path register in which at each discrete instant (i)
 10 at least n previous bits $(b_{i-1}, \dots, b_{i-n'}, b_{i-n'-1}, \dots, b_{i-n}, \dots)$ are stored commencing at an appropriate first previous bit (b_{i-1}) for $2^{n'}$ states.

2. Receiver as claimed in Claim 1, characterized in that the equalizer comprises a control and arithmetic logic which forms probability parameters for a state transition (S_i, S_{i+1}) on the basis of the $n'+1$ bits $(b_i, \dots, b_{i-n'})$ featuring this state transition and stored in the memory means and on the basis of the $n-n'$ bits $(b_{i-n'-1}, \dots, b_{i-n})$ of the memory path register, which control and arithmetic logic forms a minimum "0"-path and a minimum "1"-path respectively, on the basis of the bit sequences $(b_i, b_{i-1}, \dots, b_{i-n'+1}, b_{i-n'})$ of all the $2^{n'}$ possible "0"-paths and "1"-paths and forms appropriate overall probability parameters, which control and arithmetic logic decides that the binary value assigned to the smaller of the two considered
 15 overall probability parameters is an estimate (\hat{b}_{i-n}) for the bit b_{i-n} , and which control and arithmetic logic forms reliability information $(P(\hat{b}_{i-n}))$ for this estimate (\hat{b}_{i-n}) on the basis of the two considered overall probability parameters.

3. Receiver as claimed in Claim 1 or 2, characterized in that the memory path register has a storage depth of M previous bits, with $M \geq n$, in that at instant i an estimate (\hat{b}_{i-N})
 25 is taken from the minimum "0"-path of the memory path register for the bit b_{i-N} with $n' < N < M$ if the overall probability parameter of the minimum "0"-path is smaller than the overall probability parameter of the minimum "1"-path, otherwise from the minimum "1"-path, while a correct assignment of the estimate (\hat{b}_{i-N}) to the reliability information $(P(\hat{b}_{i-N}))$ is obtained by delaying the reliability information $(P(\hat{b}_{i-N}))$ by $N-n'$ time intervals.

30 4. Receiver as claimed in one of the Claims 1 to 3, characterized in that the memory path register has a storage depth of M previous bits, with $M \geq n$, in that at instant i



reliability information ($\hat{P}(b_{i-N})$) is formed for a bit (b_{i-N}) with $n' < N \leq M$ and the reliability information ($\hat{P}(b_{i-N})$) is substituted by a predeterminable substitute value if either only "0"-paths with $b_{i-N} = 0$ or only "1"-paths with $b_{i-N} = 1$ exist at instant i .

5 Receiver as claimed in one of the Claims 1 to 4, characterized in that the reliability information is formed by the ratio between the probability values of the two selected paths.

6 Receiver as claimed in one of the Claims 1 to 5, characterized in that the squared distance of the probability of the transition between two states is used as a metric of a probability parameter and the metric formed for a state transition is added to the overall metric determined so far to form the overall metric of an overall probability parameter.

7 Receiver as claimed in one of the Claims 1 to 6, characterized in that the overall metric of the minimum "0"-path is subtracted from the overall metric of the minimum "1"-path and in that the sign of the difference denotes the estimate and the absolute difference value denotes the reliability information assigned to the estimate.

8 Receiver as claimed in one of the Claims 1 to 7, characterized in that the reliability information is corrected by a value depending on a determined noise power.

9 Receiver as claimed in one of the Claims 1 to 8, in which information signals (x) to be transmitted are encoded into the bits (b) by means of a convolution encoder at the transmitter end, characterized in that a decoder operating as a convolution decoder is arranged after the equalizer in this system, which decoder, when decoding, processes not only the estimated bits (\hat{b}) but also the reliability information ($\hat{P}(\hat{b})$) assigned to these bits.

10 Digital transmission system comprising a receiver as claimed in one of the Claims 1 to 9.

11 A digital transmission system substantially as described herein with reference to the accompanying drawings.

Dated this second Day of December 1994



ABSTRACT:

Receiver for a digital transmission system.

The invention relates to a receiver for a digital transmission system comprising a transmit channel having a storage depth n with an analog signal processing section, which receiver comprises an analog-to-digital converter and an equalizer which has a digital signal processing section that includes a memory means with a register for storing state transitions.

For a reduction of manufacturing costs there is proposed that the registers (331, 332, 333) of the memory means (33) all comprise $2^{n'}$ memory locations, with $1 \leq n' < n$, that the memory means (33) comprises a memory path register (334) in which at each discrete instant (i) at least n previous bits ($b_{i-1}, \dots, b_{i-n'}, b_{i-n'-1}, \dots, b_{i-n}$, ...) are stored for $2^{n'}$ states commencing at a first previous bit (b_{i-1}). A minimum "0"-path or minimum "1"-path respectively, and the assigned overall probability parameters are formed by means of the bit sequences of all the $2^{n'}$ possible "0"-paths or "1"-paths respectively, having the smallest probability parameter. The binary value which is assigned to the smaller of the two considered overall probability parameters has an estimate \hat{b} for the bit b_{i-n} and reliability information $P(\hat{b})$ for this estimate \hat{b} is formed on the basis of the two considered overall probability parameters.

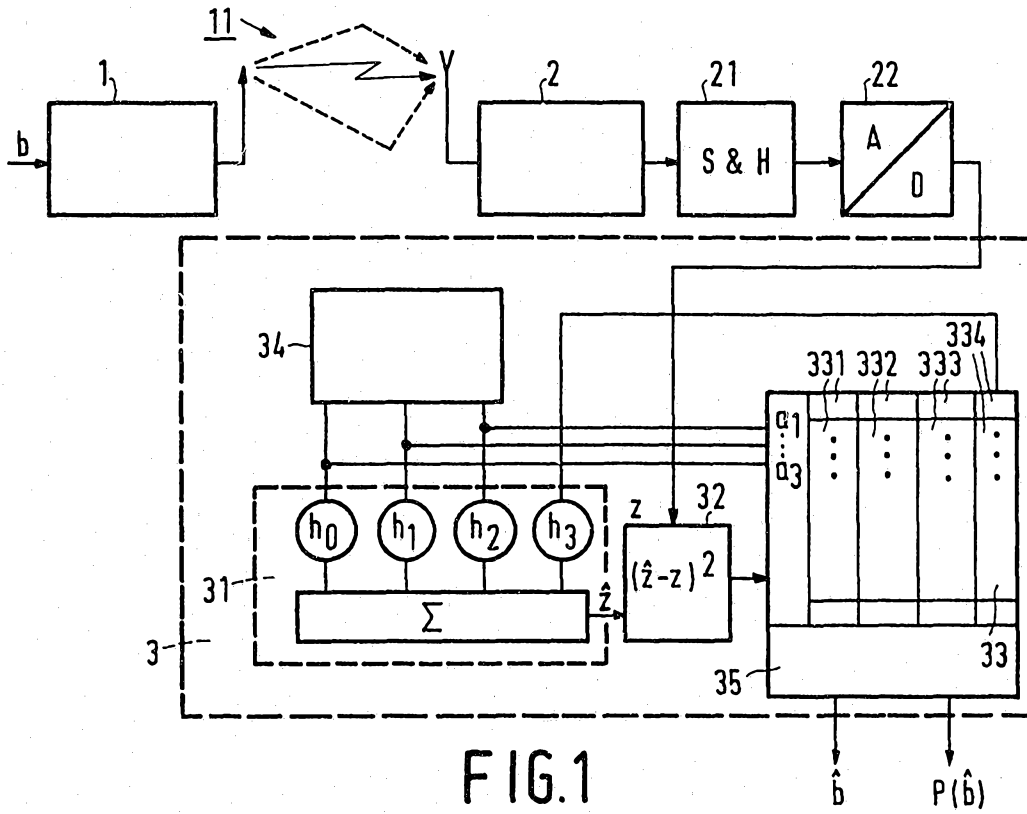

FIG. 1

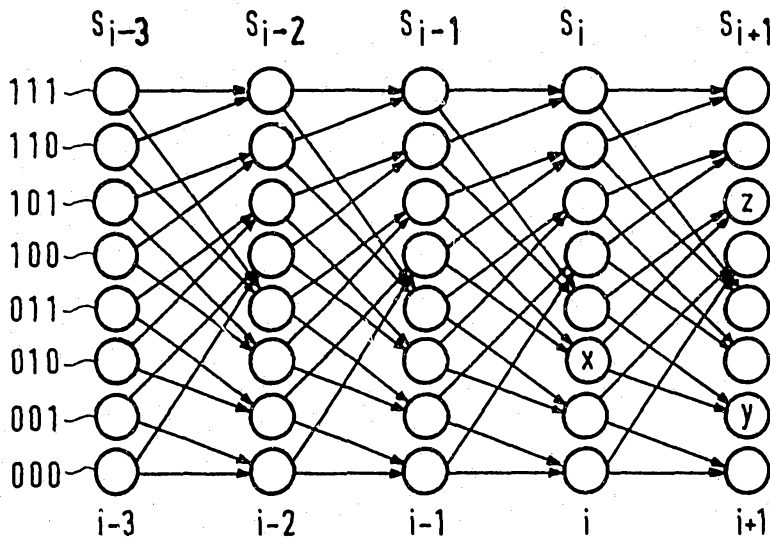

FIG. 2

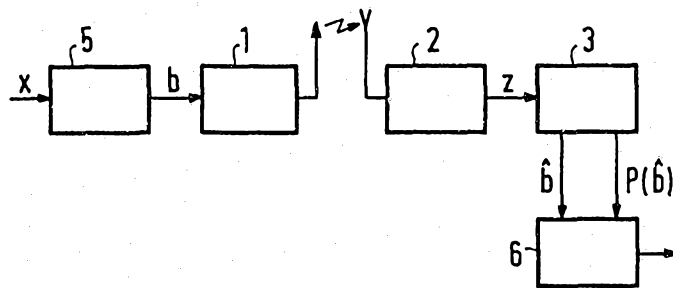

FIG. 6

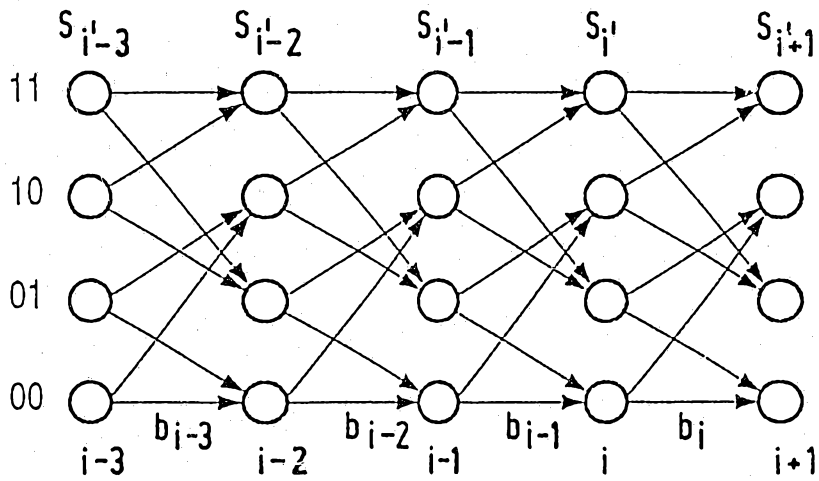

FIG. 3

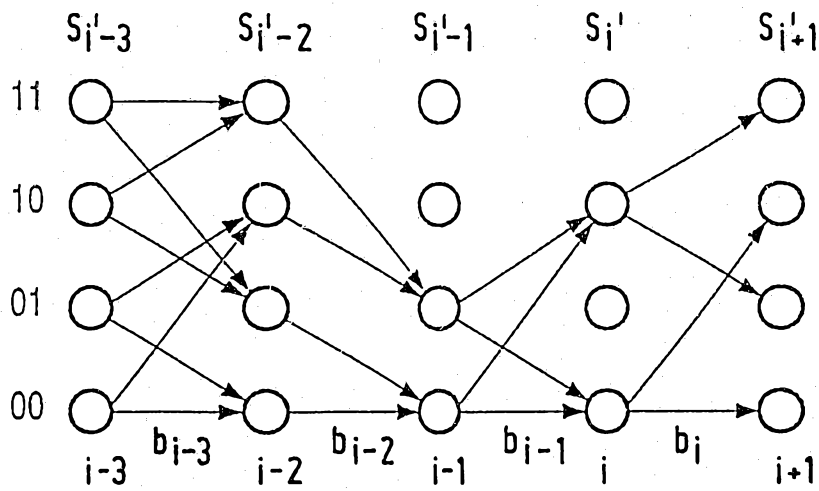

FIG. 4

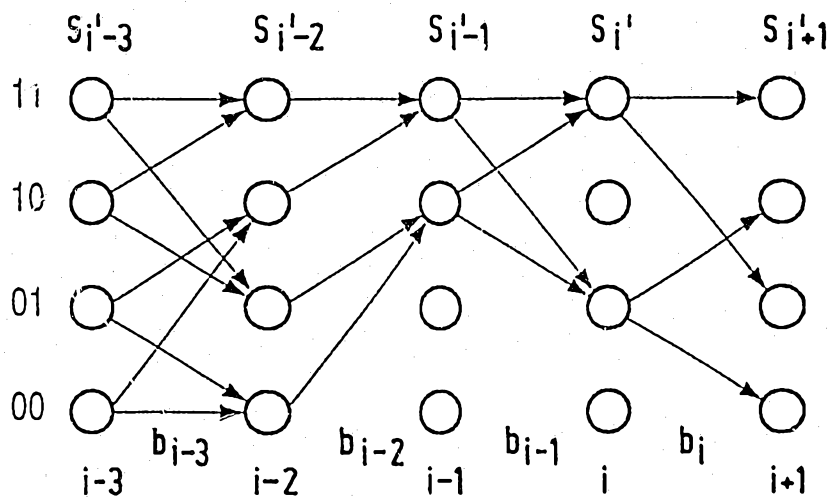

FIG. 5