



- (51) International Patent Classification:  
*B65D 5/02* (2006.01)
- (21) International Application Number:  
PCT/IB2014/063712
- (22) International Filing Date:  
5 August 2014 (05.08.2014)
- (25) Filing Language:  
Italian
- (26) Publication Language:  
English
- (30) Priority Data:  
BO2013A000441 5 August 2013 (05.08.2013) IT
- (71) Applicant: **G.D S.P.A.** [IT/IT]; Via Battindamo 91, I-40133 Bologna (IT).
- (72) Inventors: **GHINI, Marco**; Via Verona 35, I-40050 Monte San Pietro (IT). **D'ALFONSO, Lorena**; Via Pietrara 52, I-45020 Lettomanoppello (IT). **NEGRINI, Stefano**; Via Longarola 21, I-40012 Calderara Di Reno (IT).
- (74) Agent: **BIANCIARDI, Ezio**; BUGNION S.p.A., Via di Corticella 87, I-40128 Bologna (IT).

(81) Designated States (unless otherwise indicated, for every kind of national protection available): AE, AG, AL, AM, AO, AT, AU, AZ, BA, BB, BG, BH, BN, BR, BW, BY, BZ, CA, CH, CL, CN, CO, CR, CU, CZ, DE, DK, DM, DO, DZ, EC, EE, EG, ES, FI, GB, GD, GE, GH, GM, GT, HN, HR, HU, ID, IL, IN, IR, IS, JP, KE, KG, KN, KP, KR, KZ, LA, LC, LK, LR, LS, LT, LU, LY, MA, MD, ME, MG, MK, MN, MW, MX, MY, MZ, NA, NG, NI, NO, NZ, OM, PA, PE, PG, PH, PL, PT, QA, RO, RS, RU, RW, SA, SC, SD, SE, SG, SK, SL, SM, ST, SV, SY, TH, TJ, TM, TN, TR, TT, TZ, UA, UG, US, UZ, VC, VN, ZA, ZM, ZW.

(84) Designated States (unless otherwise indicated, for every kind of regional protection available): ARIPO (BW, GH, GM, KE, LR, LS, MW, MZ, NA, RW, SD, SL, SZ, TZ, UG, ZM, ZW), Eurasian (AM, AZ, BY, KG, KZ, RU, TJ, TM), European (AL, AT, BE, BG, CH, CY, CZ, DE, DK, EE, ES, FI, FR, GB, GR, HR, HU, IE, IS, IT, LT, LU, LV, MC, MK, MT, NL, NO, PL, PT, RO, RS, SE, SI, SK, SM, TR), OAPI (BF, BJ, CF, CG, CI, CM, GA, GN, GQ, GW, KM, ML, MR, NE, SN, TD, TG).

**Published:**

— without international search report and to be republished upon receipt of that report (Rule 48.2(g))

(54) Title: RIGID CONTAINER

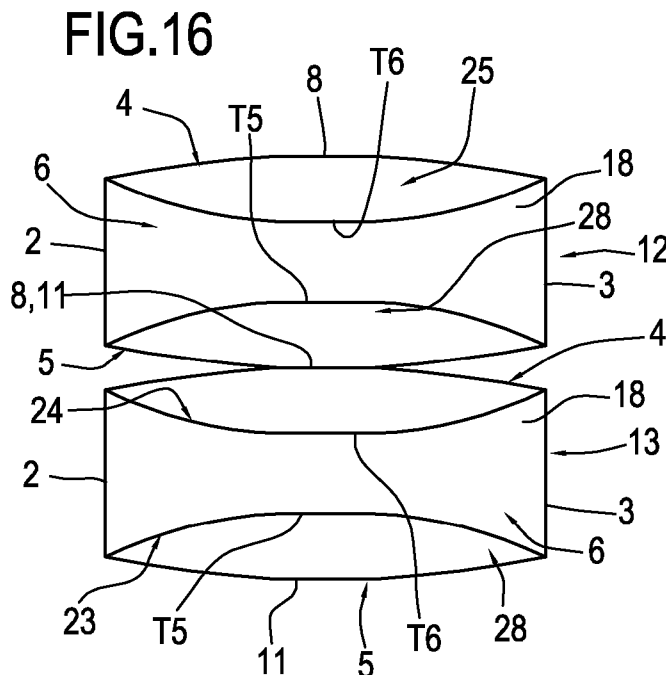

(57) Abstract: Described is a rigid container for containing articles, preferably solid soap, the container (1) extending along a main axis (1a) and comprising a top wall (2) and a bottom wall (3) lying in respective planes transversal to the main axis (1a), and a front face (4), a rear face (5), which extend from the top wall (2) to the bottom wall (3) and two sides or lateral faces (6) which extend from the top wall (2) to the bottom wall (3); the front face (4) of the container (1) comprises a convex front panel (7) which has a first supporting portion (8), and the rear face (9) of the container (1) comprises a rear panel (10) which has a second supporting portion (11) shaped to mutually match the first supporting portion (8).

## DESCRIPTION

### RIGID CONTAINER

#### Technical field

This invention relates to a rigid container.

More specifically, by "rigid container" is meant a carton for containing articles such as, for example, solid soap or bars of soap, without thereby  
5 limiting the invention.

#### Background art

Typically, these cartons are substantially in the shape of parallelepipeds, which makes them practical to transport and to arrange on the shelves in  
10 points of sale and warehouses.

Since the overall impression of the article contained in the carton is, however, given by the shape of the carton, market attention continues to be focussed on developing containers with attractive shapes having more  
consumer appeal.

15 Rigid containers with special shapes, however, have evident drawbacks in terms of stackability.

This is not acceptable from the point of view of logistics because the shelves where the containers are displayed in points of sale must hold a defined number containers stacked in orderly fashion.  
20

#### Aim of the invention

This invention has for an aim to provide a rigid container as set out in independent claim 1, to overcome the above mentioned drawbacks of the prior art.  
25

#### Brief description of the drawings

The invention is described below with reference to the accompanying

drawings, which illustrate a non-limiting embodiment of it, in which:

- Figure 1 is a first schematic perspective view showing a first embodiment of a rigid container according to the invention in a closed condition;
- 5 - Figure 2 is a second schematic perspective view showing the rigid container of Figure 1 in a closed condition;
- Figure 3 is a schematic front or rear view of the rigid container of Figure 1;
- Figure 4 is a schematic side view of the rigid container of Figure 1;
- 10 - Figure 5 is a schematic plan view of the rigid container of Figure 1;
- Figure 6 is a first schematic perspective view showing a second embodiment of a rigid container according to the invention in a closed condition;
- Figure 7 is a second schematic perspective view showing the rigid container of Figure 6 in a closed condition;
- 15 - Figure 8 is a schematic front view of the rigid container of Figure 6;
- Figure 9 is a schematic side view of the rigid container of Figure 6;
- Figure 10 is a schematic plan view of the rigid container of Figure 6;
- Figure 11 is a first schematic perspective view showing a third embodiment of a rigid container according to the invention in a closed condition;
- 20 - Figure 12 is a second schematic perspective view showing the rigid container of Figure 11 in a closed condition;
- Figure 13 is a schematic front view of the rigid container of Figure 11;
- 25 - Figure 14 is a schematic side view of the rigid container of Figure 11;
- Figure 15 is a schematic plan view of the rigid container of Figure 11;
- Figures 16 to 18 are schematic side views showing two stacked containers according to the first, second and third embodiments, respectively;
- 30 - Figures 19 to 21 are schematic plan views showing the blanks from which are obtained the containers according to the first, second and third

embodiments, respectively.

### **Detailed description of preferred embodiments of the invention**

5 The reference numeral 1 denotes a rigid container for containing solid articles 1b, preferably bars of soap.

The rigid container 1 for containing articles extends along a main axis 1a and comprises at least a top wall 2 and a bottom wall 3 lying in respective planes transversal to the main axis 1a. More specifically, the top wall 2 and the bottom wall 3 are opposite to each other and lie in planes at right  
10 angles to the main axis 1a and are thus parallel to each other.

The container 1 also comprises a plurality of perimeter walls extending from the top wall 2 to the bottom wall 3. In this text, the term "perimeter wall" comprises the terms "faces" and "panels" described in detail below.

15 At least three of the perimeter walls are outwardly convex and at least two of the perimeter walls are inwardly concave. More specifically, the concave perimeter walls are interposed between, and connect, the convex perimeter walls.

Further, at least one of the convex perimeter walls has a first supporting portion 8 and the wall 9 opposite to the first supporting portion 8  
20 comprises a second supporting portion 11. The first and second supporting portions 8, 11 are parallel and flat or have oppositely shaped profiles on the corresponding walls on which they are made.

The first and second supporting portions 8, 11 are designed to allow the container to be stacked, as described below.

25 In the first, second and third embodiments of the container 1, the top wall 2 and the bottom wall 3 are defined by respective flat panels.

Preferably, the container 1 comprises at least one hinged panel for opening and closing the container 1 and which defines at least one of either the top wall 2 or the bottom wall 3.

30 The top wall 2 or the bottom wall 3 may each be defined by at least two superposed panels connected to each other preferably by an adhesive

substance.

The container 1 then comprises a front face 4, a rear face 5 extending from the top wall 2 to the bottom wall 3, and two sides or lateral faces 6, extending from the top wall 2 to the bottom wall 3.

5 More specifically, the front face 4 and the rear face 5 comprise a front panel 7 and a rear panel 10, respectively.

In all the embodiments of this invention, at least the front panel 7 is convex and has a first supporting portion 8.

10 The rear face 5 comprises a rear panel 10 having a second supporting portion 11.

The rear panel 10 and the front panel 7 are connected to the top wall 2 and to the bottom wall 3 by an upper connecting edge 31 and a lower connecting edge 32, respectively.

15 Advantageously, the first and second supporting portions 8, 11 are shaped to mutually match.

The term "to match" as used here means that the profile of the first supporting portion 8 fits onto the profile of the second supporting portion 11 without leaving any gaps.

20 That way, a first container 12 can be stacked on a second container 13 by superposing the second supporting portion 11 of the first container 12 on the first supporting portion 8 of the second container 13.

25 Advantageously, the stack formed by the first container 12 on the second container 13 is stable because the second supporting portion 11 of the first container 12 is superposed on the first supporting portion 8 of the second container 13 uninterruptedly.

With reference to Figures 1 to 5, in the first embodiment of the container 1, the convex front panel 7 has a first supporting portion 8 which is defined by a flat surface.

30 Preferably, the flat supporting portion 8 is located at a median position on the front panel 7 so as to guarantee that the container 1 is balanced when stacked.

It should be noted that the convex front panel 7 is delimited by a first and a second fold line 14, 15, each defined by two curved stretches between which are interposed a first and a second straight stretch T1 and T2, respectively. The first supporting portion 8 is thus a flat surface defined by the first straight stretch T1 and the second T2.

More precisely, the first straight stretch T1 of the first fold line 14 is interposed between two curved stretches.

The second straight stretch T2 of the second fold line 15 is interposed between two curved stretches.

Each of the curved stretches of the first and second fold lines 14, 15 extends from a respective vertex of the top wall 2 and of the bottom wall 3. In other words, the first and second fold lines 14, 15 extend from respective vertices of the top wall 2 and of the bottom wall 3.

The term "vertex" means the meeting point between two respective edges delimiting respectively the top wall 2 and the bottom wall 3.

The curved stretches of the first and second fold lines 14, 15 give the front panel 7 its convex shape, while the first and second straight stretches T1 and T2 define and delimit the first flat supporting portion 8.

In the first embodiment of the container 1, the rear face 5 comprises a convex rear panel 10 which has the second flat supporting portion 11.

In the same way as the front panel 7, the convex rear panel 10 is delimited by a third and a fourth fold line 16, 17, each defined by two curved stretches between which are interposed a third and a fourth straight stretch T3 and T4, respectively, which delimit the second flat supporting portion 11.

In other words, the third and fourth fold lines 16, 17 extend from respective vertices of the top wall 2 and of the bottom wall 3, different from the vertices from which the first and second fold lines 14, 15 extend.

More precisely, the respective third straight stretch T3 of the third fold line 16 is interposed between two curved stretches.

The respective fourth straight stretch T4 of the fourth fold line 17 is

interposed between two curved stretches.

Each of the curved stretches of the third and fourth fold lines 16,17 extends from a respective vertex of the top wall 2 and of the bottom wall 3.

5 The curved stretches of the third and fourth fold lines 16, 17 give the rear panel 10 its convex shape, while the third and fourth straight stretches T3 and T4 define and delimit the second flat supporting portion 11.

The first and the second supporting portion 8, 11 of the front face 4 and of the rear face 5, respectively, are parallel and opposite to each other relative to the main axis 1a.

10 At least one of the two sides 6 of the container 1 comprises a convex lateral panel 18 having at least one supporting portion 19.

Preferably, both of the sides 6 of the container 1 each comprise a respective first and second convex lateral panel 18 having a third and a fourth supporting portion 19, 20 respectively.

15 The first and second lateral panels 18 are delimited respectively by a fifth and a sixth fold line 23, 24, each defined by two curved stretches between which are interposed a fifth and a sixth straight stretch T5 and T6, respectively, which delimit the third and fourth flat supporting portions 19, 20, respectively.

20 More precisely, the respective fifth straight stretch T5 of the fifth fold line 23 is interposed between two curved stretches.

The respective sixth straight stretch T6 of the sixth fold line 24 is interposed between two curved stretches.

25 Each of the curved stretches of the fifth and sixth fold lines 23, 24 extends from a respective vertex of the top wall 2 and of the bottom wall 3.

In other words, the fifth and sixth fold lines 23, 24 of each lateral panel 18 extend from respective vertices of the top wall 2 and of the bottom wall 3.

30 The curved stretches of the fifth and sixth fold lines 23, 24 give the lateral panel 18 its convex shape, while the fifth and sixth straight stretches T5 and T6 define and delimit the third and fourth flat supporting portions 19, 20 respectively.

The third and fourth supporting portions 19, 20 of the lateral faces 6, respectively, are parallel and opposite to each other relative to the main axis 1a.

5 The straight stretches T1, T2, T3, T4, T5, T6 of the respective fold lines 14, 15, 16, 17, 23, 24 extend along a direction parallel to the main axis 1a. Preferably, the straight stretches T1, T2, T3, T4, T5, T6 of the respective fold lines 14, 15, 16, 17, 23, 24 are positioned at the same distance from the main axis 1a.

10 The container 1 comprises at least one concave panel 25, 26, 27, 28 connecting two respective faces 4, 5, 6 which are consecutive with each other.

More specifically, in the first, second and third embodiments, a first and a second concave panel 25, 26 each connect the front panel 7 to a respective side or lateral face 6.

15 In the first embodiment, a third and a fourth concave panel 27, 28 each connect the rear panel 10 to a respective side or lateral face 6.

The first, second, third and fourth concave connecting panels 25, 26, 27, 28 extend from a respective vertex of the top wall 2 to a respective vertex of the bottom wall 3.

20 It should be noted that the first and second concave connecting panels 25, 26 are delimited by the first and sixth fold lines 14, 24 and by the second and sixth fold lines 15, 24, respectively.

25 The third and fourth second concave connecting panels 27, 28 are delimited by the third and fifth fold lines 16, 23 and by the fourth and fifth fold lines 17, 23, respectively.

In the second embodiment, with reference to Figures 6 to 10, the rear face 5 of the container 1 comprises a concave panel 29 and entirely defines the second supporting portion 11.

30 More precisely, the concave panel 29 extends from a pair of vertices of the top wall 2, positioned along the upper connecting edge 31, to a pair of vertices of the bottom wall 3 positioned along the lower connecting edge

32.

In the second embodiment, the front face 4 of the container 1 comprises a convex front panel 7 which also entirely defines the first supporting portion 8. More specifically, the front panel 7 is delimited by a first and a second fold line 14, 15.

The front panel 7 and the rear panel 29 are thus parallel to each other and allow stacking two or more containers by superposing these panels.

The first and second fold lines 14, 15 are curved and extend from respective vertices of the top wall 2 and of the bottom wall 3.

Unlike the first embodiment of the container 1, the first and second fold lines 14, 15 do not have any straight stretch.

Consequently, the front panel 7 is an uninterruptedly convex surface.

In this embodiment, the container 1 comprises a first and a second concave panel 25, 26 connecting the front face 4 to a respective side or lateral face 6.

It should be noted that a sixth fold line 24 delimits with the first and second fold lines 14, 15 the first and second concave connecting panels 25, 26, respectively.

The sixth fold line 24 is curved and extends from respective vertices of the top wall 2 and of the bottom wall 3.

Unlike the first embodiment of the container 1, the sixth fold lines 24 does not have any straight stretch.

The first and second concave panels 25, 26 extend from a respective vertex of the top wall 2 to a respective vertex of the bottom wall 3.

In the third embodiment, with reference to Figures 11 to 15, the convex front panel 7 of the container 1 has a first supporting portion 8 which is flat.

As regards the front panel 7 and the first and second concave connecting panels 25, 26, the reader is referred to the description of the first embodiment of the container 1.

It should be noted that the first and second concave connecting panels 25,

26 are delimited by the first and sixth fold lines 14, 24 and by the second and sixth fold lines 15, 24, respectively.

Unlike the first and second embodiments, the rear face 5 of the container 1 in the third embodiment comprises a flat rear panel 10 which entirely  
5 defines the second supporting portion 11.

The flat rear panel 10 and the first supporting portion 8 are opposite and parallel to each other.

In this embodiment, the flat rear panel 10 is connected to the sides 6 by respective side connecting edges 29, 30 which define a fifth fold line.

10 In this case, each side 6 comprises a convex lateral panel 18 having at least one respective supporting portion. The lateral panel 18 is delimited by the fifth straight fold line 29, 30 and by the sixth fold line 24. As in the first embodiment, the sixth fold line 24 is curved except for a respective sixth straight stretch T6.

15 More specifically, the presence of the concave panels 25, 26 interposed between the front face and the lateral face, defines the above mentioned sixth fold line 24 so that it corresponds to the edge of the first concave panel 25 and/or of the second concave panel 26.

20 With reference to Figures 16 to 18, a first container 12 is stacked on a second container 13 and the second supporting portion 11 of the first container 12 matches with the first supporting portion 8 of the second container 13.

25 More specifically, with reference to Figure 16, the second flat supporting portion 11 of the first container 12 matches with the first flat supporting portion 8 of the second container 13, since the one is perfectly superposed on the other.

With reference to Figure 17, the concave rear panel 10 of the first container 12 stacked on the second container 13 is totally superposed and matched with the convex front panel 7 of the second container 13.

30 With reference to Figure 18, the second flat supporting portion 11 of the first container 12, defined in this case by the flat rear panel 10, matches

with the first flat supporting portion 8 of the front panel 7 of the second container 13, since the first and second flat supporting portions 8, 11 are perfectly superposed.

5 The container 1 overcomes the drawbacks of the prior art and brings important advantages.

In effect, the container 1 replicates the shape of the article 1b contained therein so as to be more appealing to the consumer.

10 Further, the use of convex panels alternated with concave panels reduces the amount of packaging material required, with savings in production costs.

Figure 19 illustrates a blank 100 from which the first embodiment of the container 1 is made by folding.

The rigid container 1 is made of a foldable material defining the top wall 2, the bottom wall 3, the front face 4, the rear face 5 and the side 6.

15 More specifically, the blank 100 from which the first embodiment of the container 1 is made comprises the first, second, third, fourth, fifth and sixth fold lines 14, 15, 16, 17, 23, 24 defining the respective panels 7, 10, 18, 25, 26, 27, 28, extending in a direction transversal to, in particular at right angles to, the main axis of extension of the blank 100.

20 From Figure 19, it is possible to observe the straight stretches T1, T2, T3, T4, T5, T6 of the respective fold lines 14, 15, 16, 17, 23, 24 relative to the curved stretches of the lines.

Figure 20 illustrates a blank 100 from which the second embodiment of the container 1 is made by folding.

25 The first, second and sixth fold lines 14, 15, 24 of this blank 100 delimit the front panel 7 and the first and second concave panels 25, 26, extending in a direction transversal to, in particular at right angles to, the main axis of extension of the blank 100.

30 The first, second and sixth fold lines 14, 15, 24 do not have straight stretches.

As may be observed in Figure 20, the side connecting edges 29,30,

extending in a direction transversal to, in particular at right angles to, the main axis of extension of the blank 100, are curved to define the concavity of the rear panel 10.

5 Figure 21 illustrates a blank 100 from which the third embodiment of the container 1 is made by folding.

More specifically, the blank 100 from which the third embodiment of the container 1 is made comprises the first, second and sixth fold lines 14, 15, 24, defining the respective panels 7, 25, 26, extending in a direction transversal to, in particular at right angles to, the main axis of extension of  
10 the blank 100.

From Figure 19, it is possible to observe the straight stretches T1, T2 and T6 of the respective fold lines 14, 15, 24 relative to the curved stretches of the lines.

As may be observed in Figure 21, the side connecting edges 29,30, extending in a direction transversal to, in particular at right angles to, the main axis of extension of the blank 100, are straight to define the flatness  
15 of the rear panel 10.

In the first, second and third embodiments of it, the blank 100 comprises a first and a second fold line 33 and 34 which extend in a direction transversal to, in particular at right angles to, the main axis of extension of  
20 the blank 100 and will define the upper and lower connecting edges 31, 32 between the front panel 7, the rear panel 10, the top wall 2 and the bottom wall 3.

**CLAIMS**

1. A rigid container (1) for containing solid articles, preferably soap, extending along a main axis (1a) and comprising at least:  
a top wall (2) and a bottom wall (3) opposite each other and lying in respective planes transversal to the main axis (1a),  
5 a front face (4) and a rear face (5), extending from the top wall (2) to the bottom wall (3), the front face (4) comprising a front panel (7) and the rear face (5) comprising a rear panel (10), at least the front panel (7) being convex, and  
two sides or lateral faces (6), extending from the top wall (2) to the bottom  
10 wall (3);  
the container being characterized in that the convex front face (7) comprises a first supporting portion (8) and the rear panel (10) comprises a second supporting portion (11); at least the first and second supporting portions (8, 11) being shaped to mutually match;  
15 a first container (12) being stackable on a second container (12) by superposing the second supporting portion (11) of the first container (12) on the first supporting portion (8) of the second container (13).
2. The rigid container (1) according to claim 1, characterized in that the convex front panel (7) is delimited by a first fold line (14) and a second  
20 fold line (15), each defined by two curved stretches between which are interposed a first straight stretch (T1) and a second straight stretch (T2), respectively, the first supporting portion (8) being a flat surface defined by the first straight stretch (T1) and the second (T2).
3. The container according to claim 2, characterized in that the rear  
25 panel (10) is convex and is delimited by a third fold line (16) and a fourth fold line (17), each defined by two curved stretches between which are interposed a third straight stretch (T3) and a fourth straight stretch (T4), respectively, the second supporting portion (11) being a flat surface defined by the third straight stretch (T3) and the fourth (T4); the first and

second supporting portions (8, 11) being parallel and opposite to each other.

4. The container according to any one of claims 1 to 3, characterized in that at least one of the two sides (6) comprises a convex side panel (18) having at least one respective supporting portion (19, 20), the convex side panel (18) being delimited by a first fold line (23) and a second fold line (24), each defined by two curved stretches between which are interposed a first straight stretch (T1) and a second straight stretch (T2), respectively, the first supporting portion (8) being a flat surface defined by the first straight stretch (T1) and the second (T2).

5. The container according to claim 1 or 2, characterized in that the rear panel (10) is flat and entirely defines the second supporting portion (11); the first and second supporting portions (8, 11) being parallel and opposite to each other.

6. The container according to claim 5, characterized in that at least one of the two sides (6) comprises a convex side panel (18) having at least one respective supporting portion, the side panel (18) being delimited by a fifth straight fold line (29, 30) corresponding to the side edge (29, 30) for connection to the flat rear panel (10) and by a sixth fold line (24) defined by two curved stretches between which is interposed a sixth straight stretch (T6), the first supporting portion (8) being a flat surface defined by the fifth fold line (29, 30) and the sixth straight stretch (T6).

7. The container according to any one of claims 1 to 6, characterized in that it comprises at least one concave panel (25, 26, 27, 28) connecting two respective faces (4, 5, 6) consecutive with each other.

8. The container according to claim 7, characterized in that the concave panel (25, 26, 27, 28) extends from one of the vertices of the top wall (3) to one of the vertices of the bottom wall (4).

9. The container according to claim 1, characterized in that the rear panel (10) is concave and entirely defines the second supporting portion (11), the first supporting portion (8) being entirely defined by the front

panel (7); the front panel (7) and the rear panel (10) being parallel to each other.

10. The container according to claim 9, characterized in that it comprises at least one concave panel (25, 26) connecting the front face (4) with one  
5 of the sides or lateral faces (6).

11. The container according to claim 9 or 10, characterized in that the concave panel (25, 26) extends from a pair of vertices of the top wall (2) to a pair of vertices of the bottom wall (3).

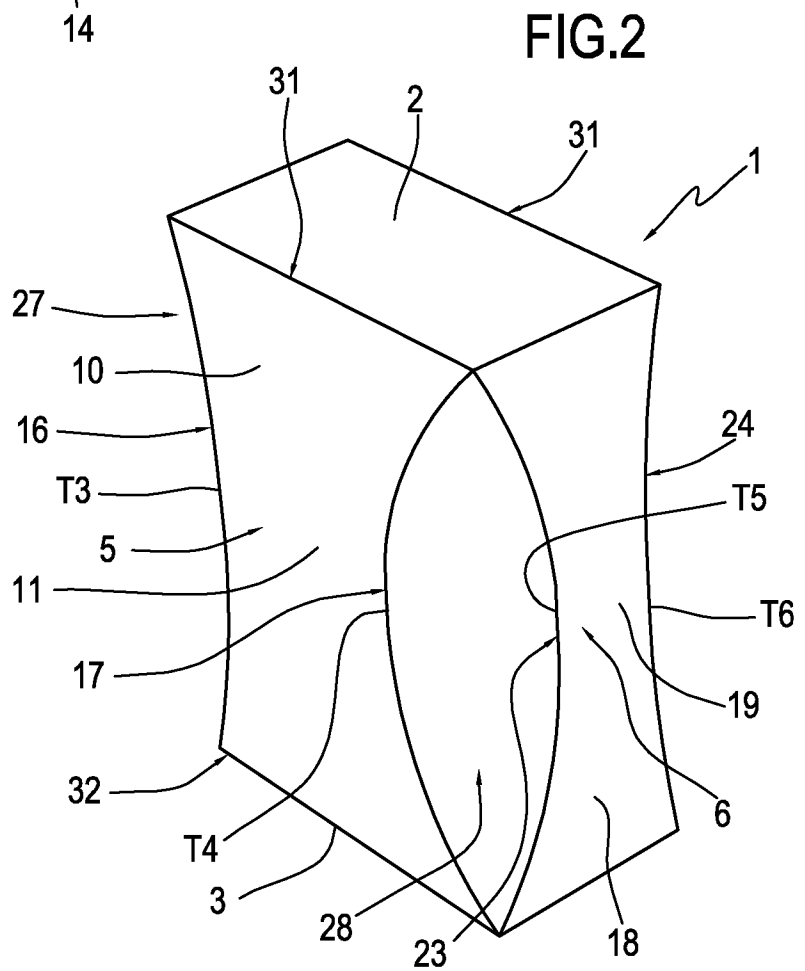
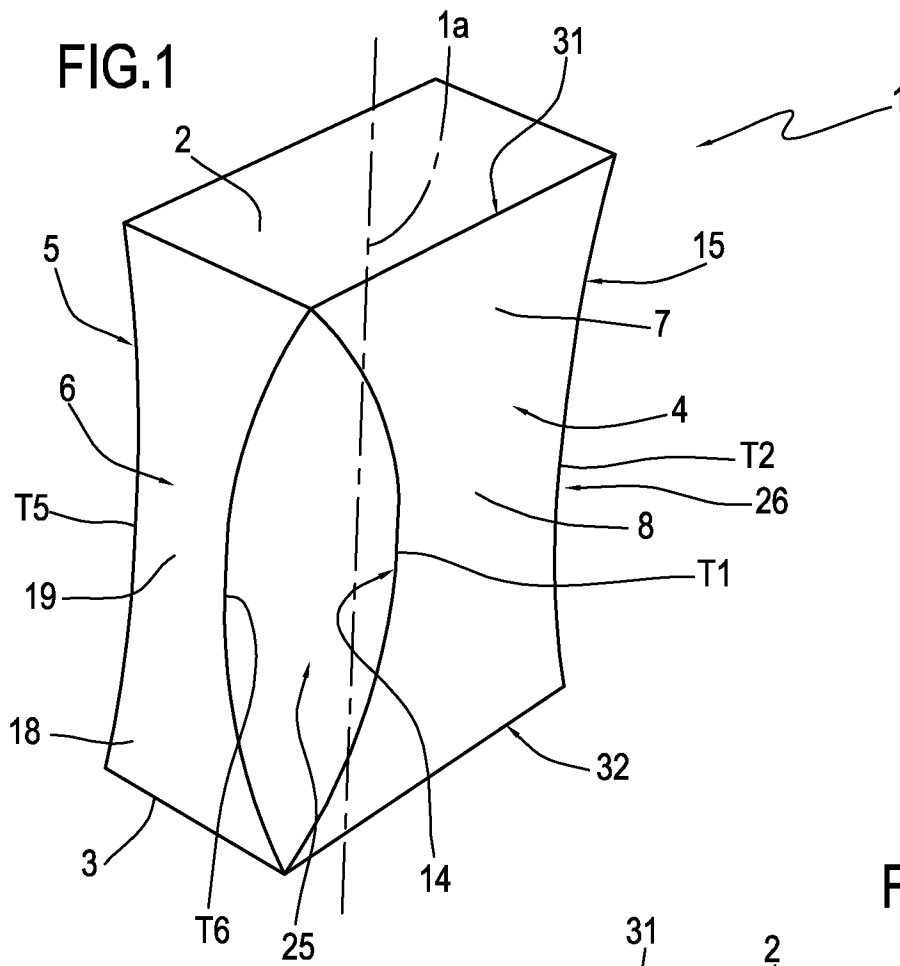

FIG.3

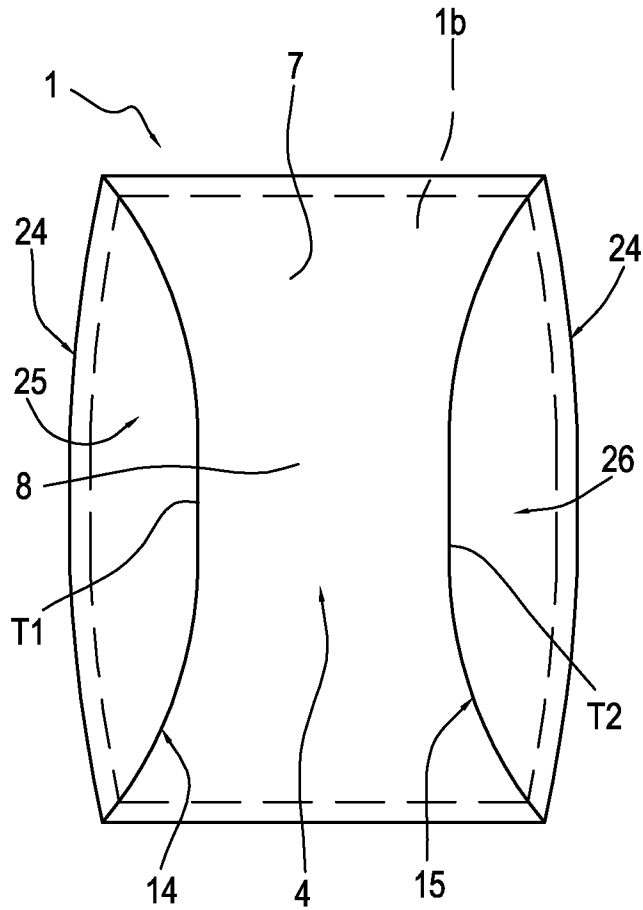

FIG.4

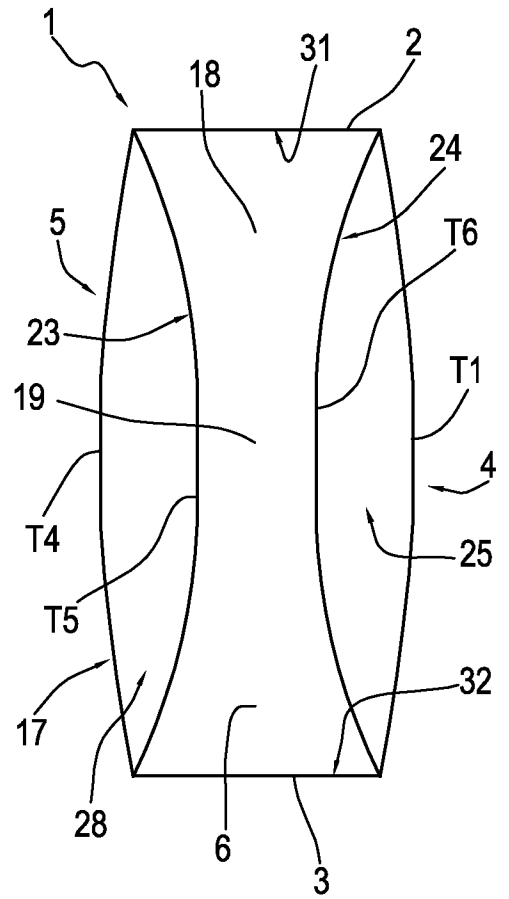

FIG.5

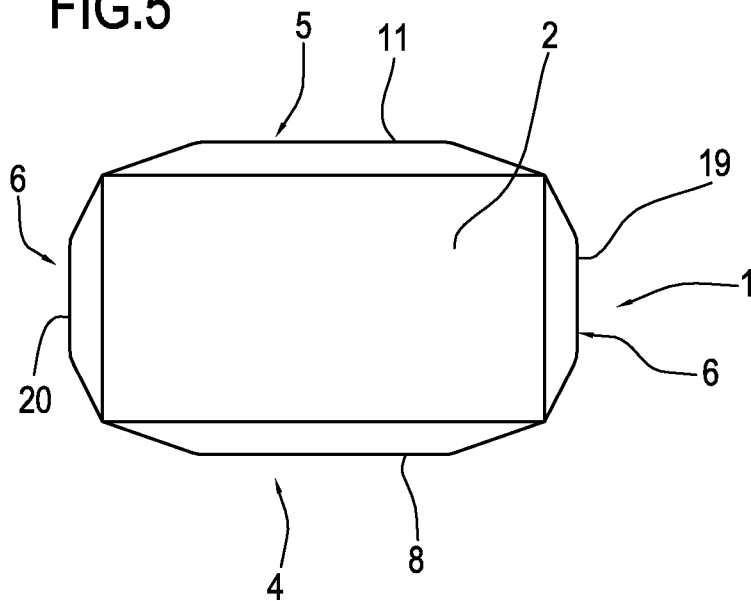

FIG.6

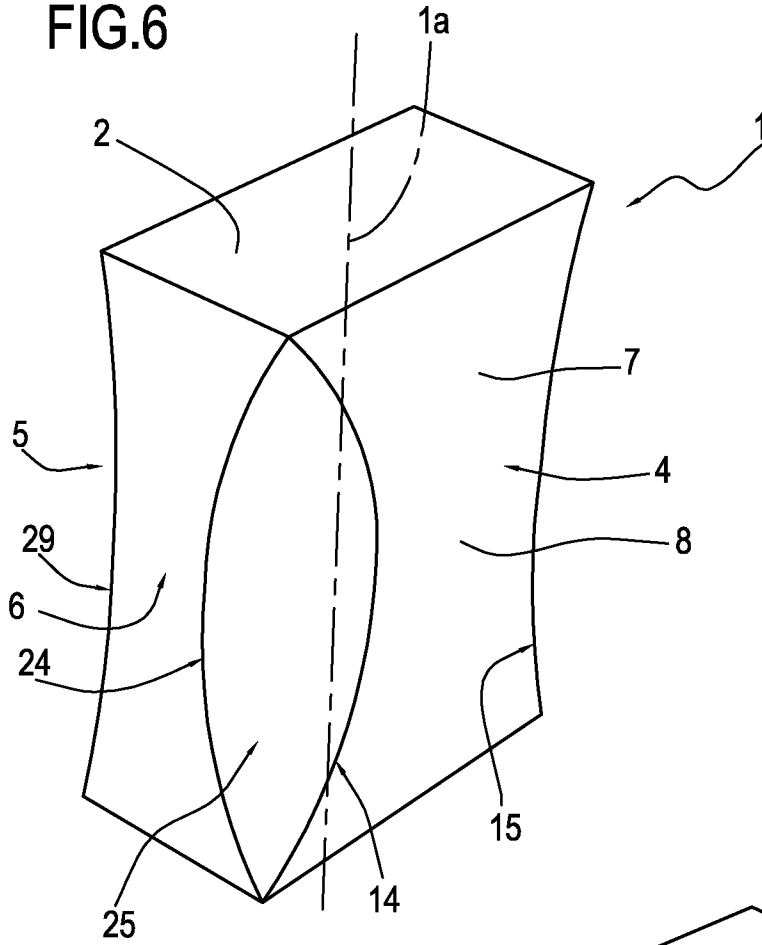

FIG.7

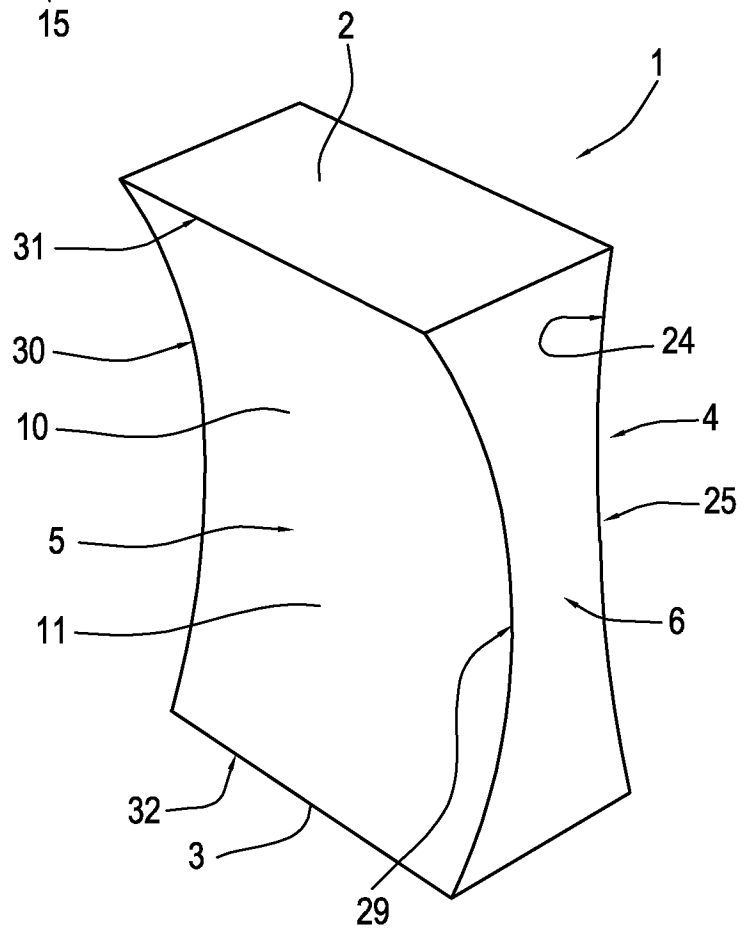

FIG.8

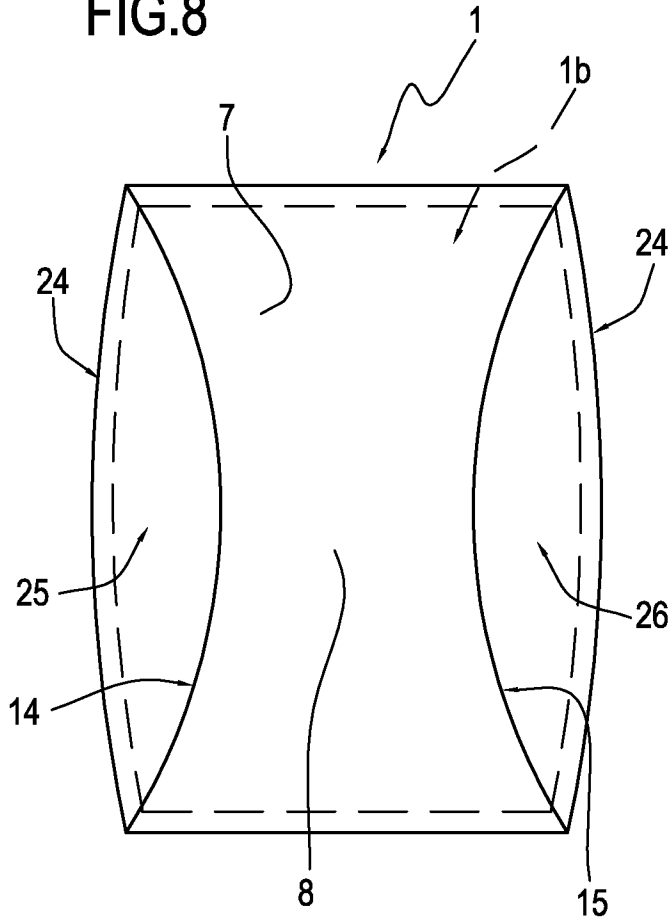

FIG.9

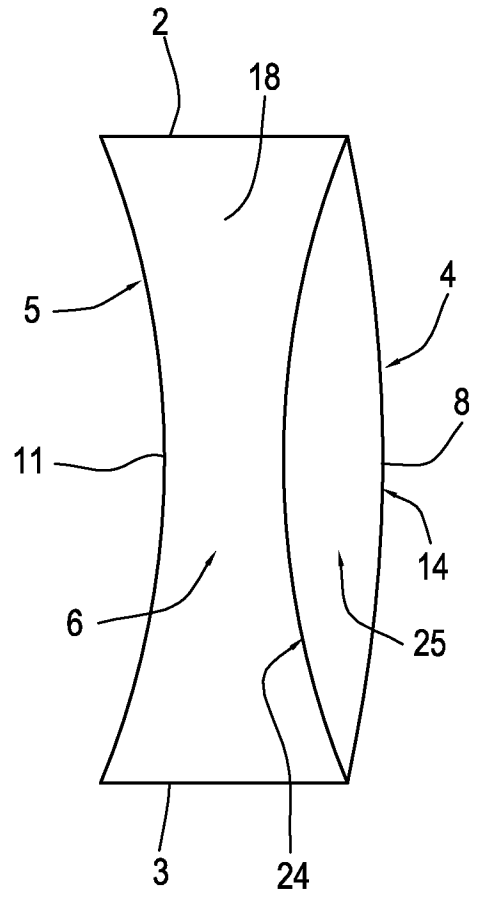
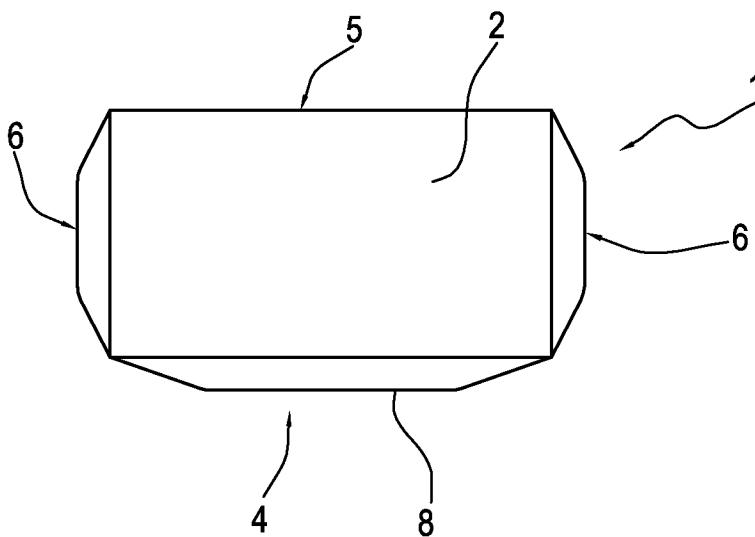

FIG.10



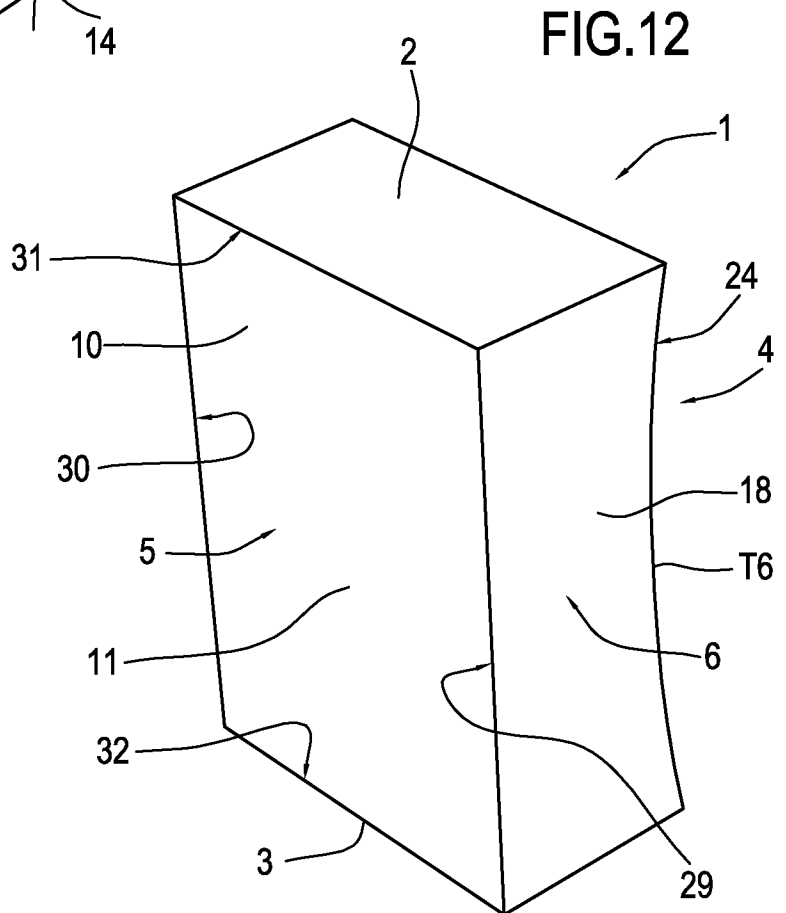
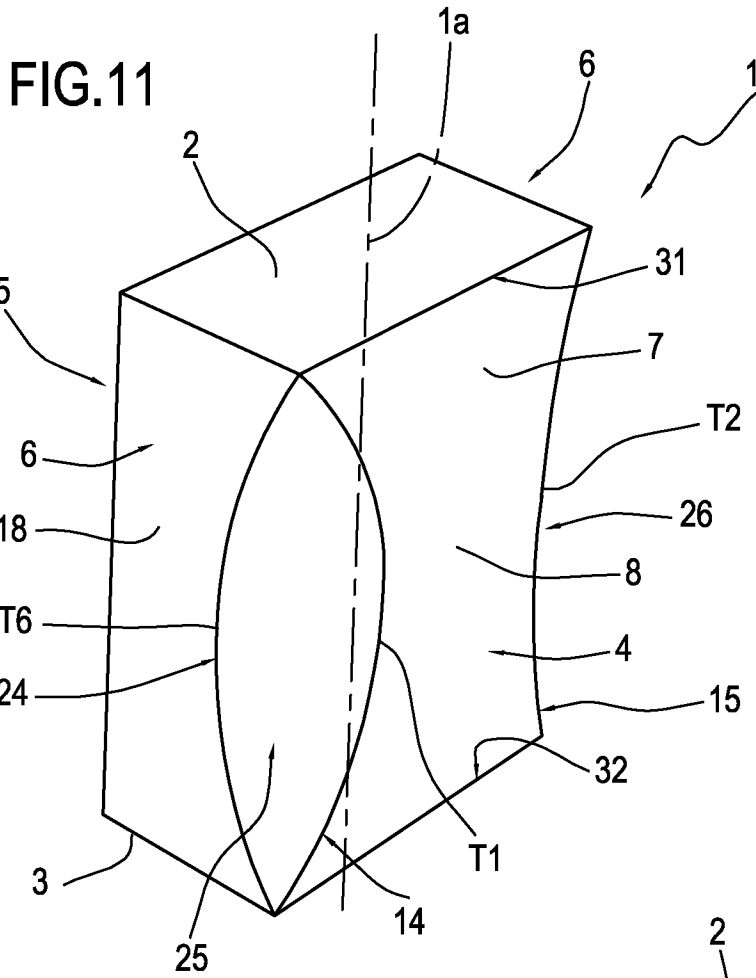

FIG.13

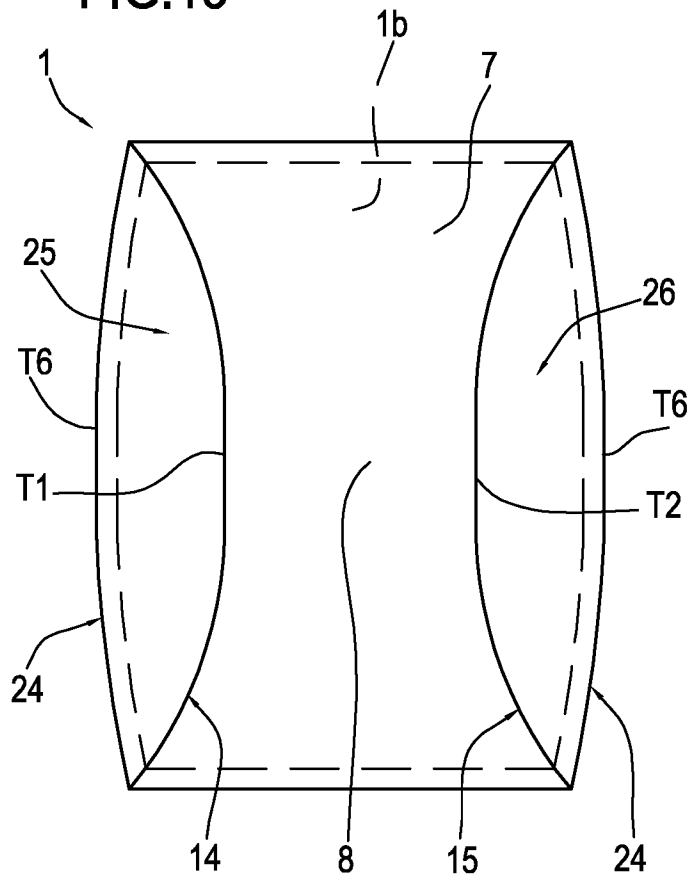

FIG.14

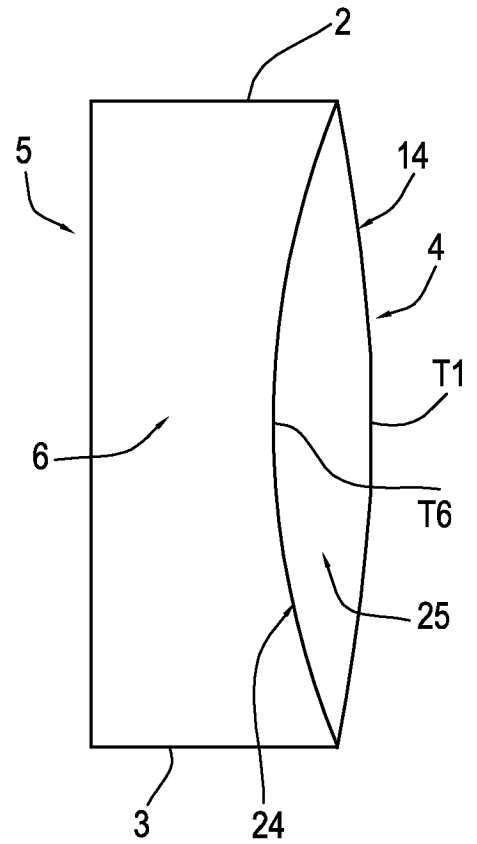

FIG.15

