

[54] APPARATUS FOR PROCESSING SHEET MATERIAL

512,800 1/1894 Buchel..... 83/220 X
 528,502 10/1894 Bennett..... 83/220
 847,536 3/1907 Zimmerman..... 83/650 X

[76] Inventor: **Karl Brand**, am Stich 2, 4125 Riehen, Switzerland

Primary Examiner—J. M. Meister
 Attorney, Agent, or Firm—Kurt Kelman

[22] Filed: **Feb. 15, 1972**

[21] Appl. No.: **226,612**

[30] Foreign Application Priority Data

Feb. 24, 1971 Switzerland..... 2688/71

[52] U.S. Cl..... 83/409, 83/220, 83/417, 83/436, 83/650

[51] Int. Cl..... B65h 17/5

[58] Field of Search 83/219, 220, 249, 401, 418, 83/421, 649, 650, 436, 533, 534, 535, 542, 562, 409, 417

[56] References Cited

UNITED STATES PATENTS

1,053,694 2/1913 Anderson..... 83/220 X

[57] ABSTRACT

Apparatus for processing sheet material, comprising cutting means to cut the sheet material and which comprise an elongated longitudinally extending bed on which the material is supported during cutting, material supplying means which reciprocate relatively to the cutting means in a longitudinal direction, driving means for feeding the sheet material towards the cutting means, deflecting and guiding means for passing the material towards the cutting means, and a carrier for supporting rolls of sheet material to be processed, the carrier being movable with the material supplying means.

7 Claims, 6 Drawing Figures

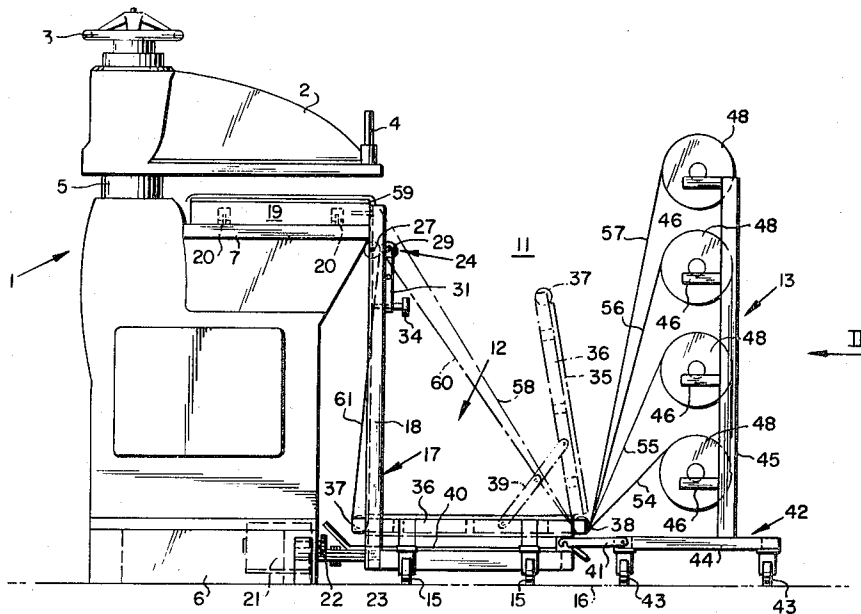

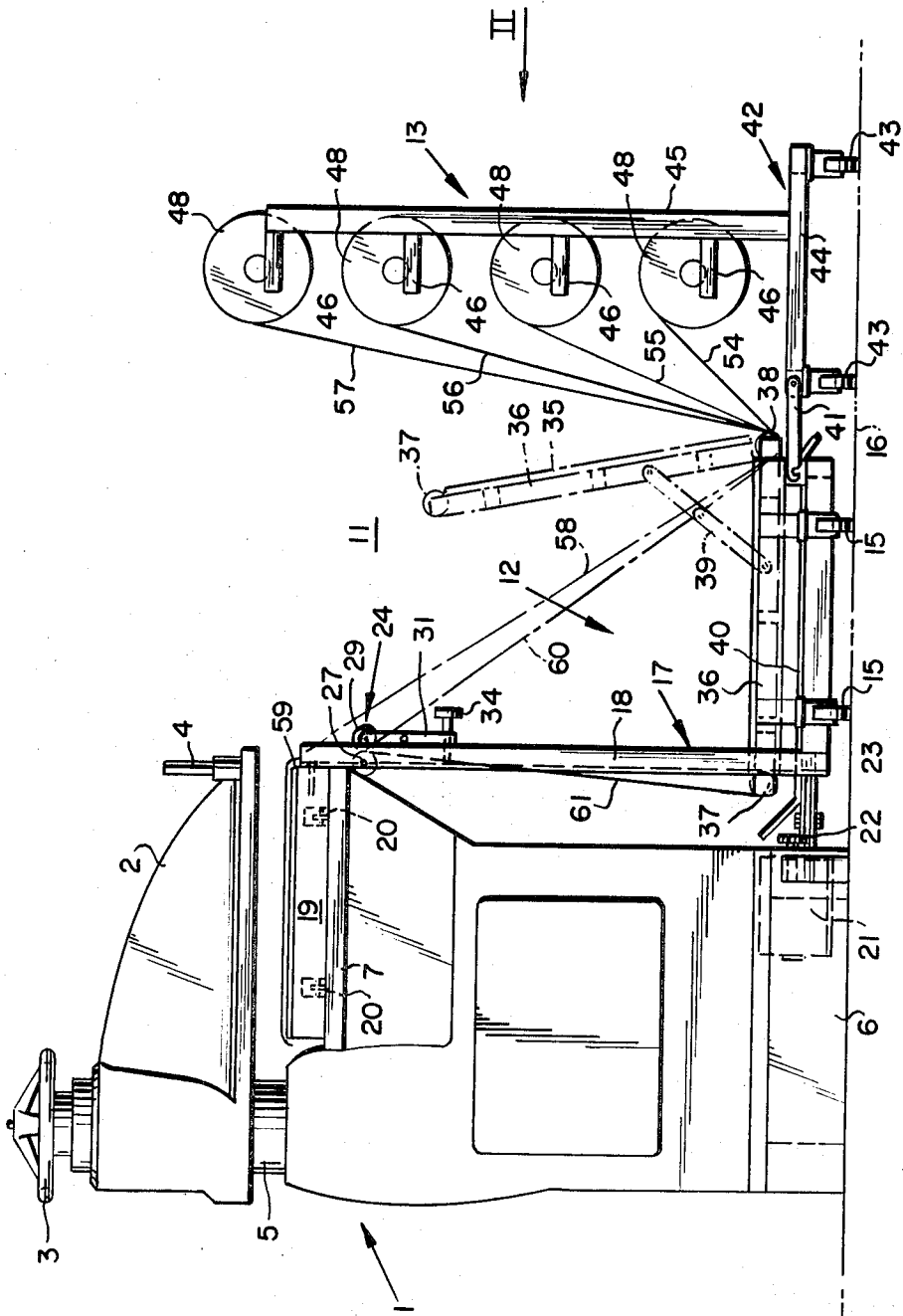

FIG. 1

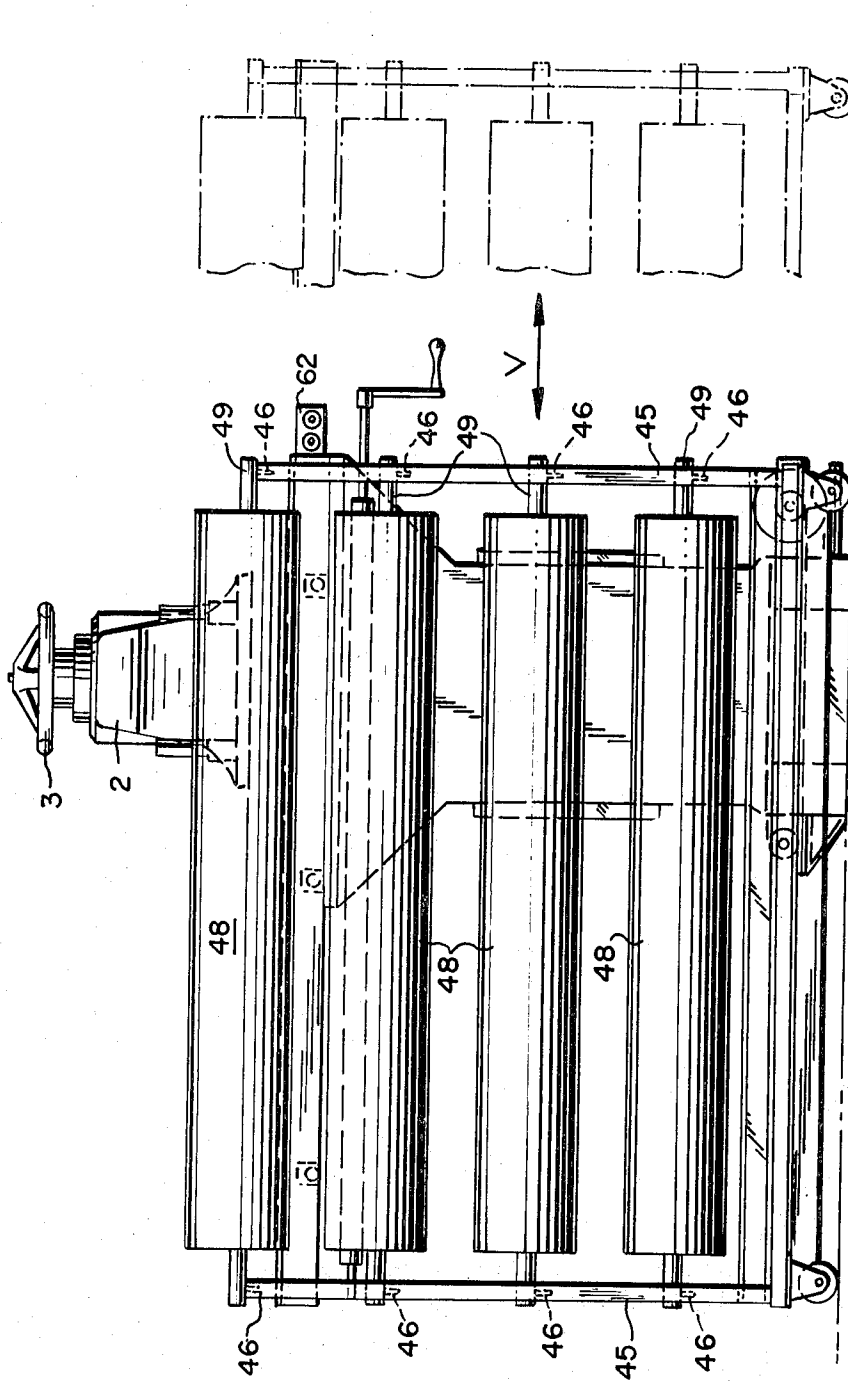

FIG.2

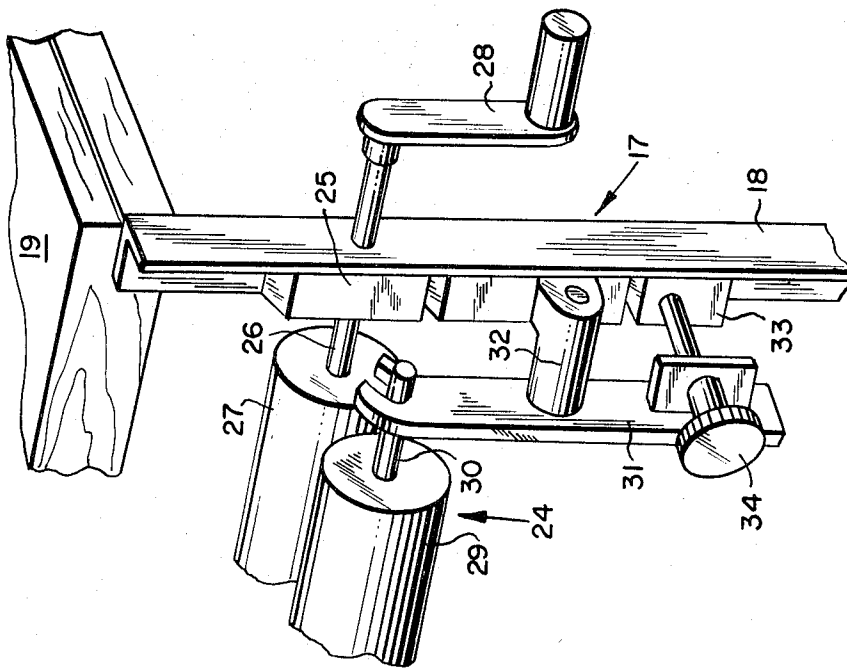

FIG. 3

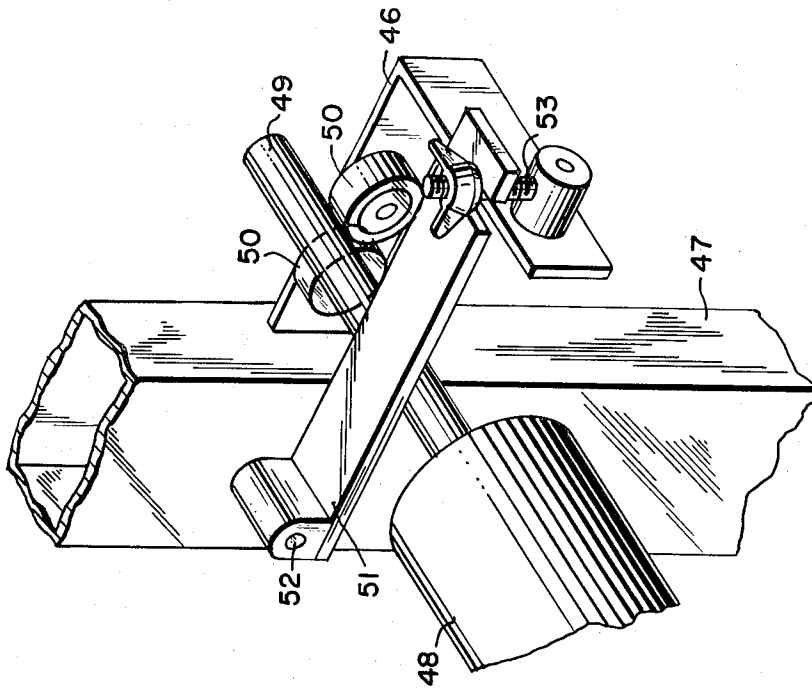

FIG. 4

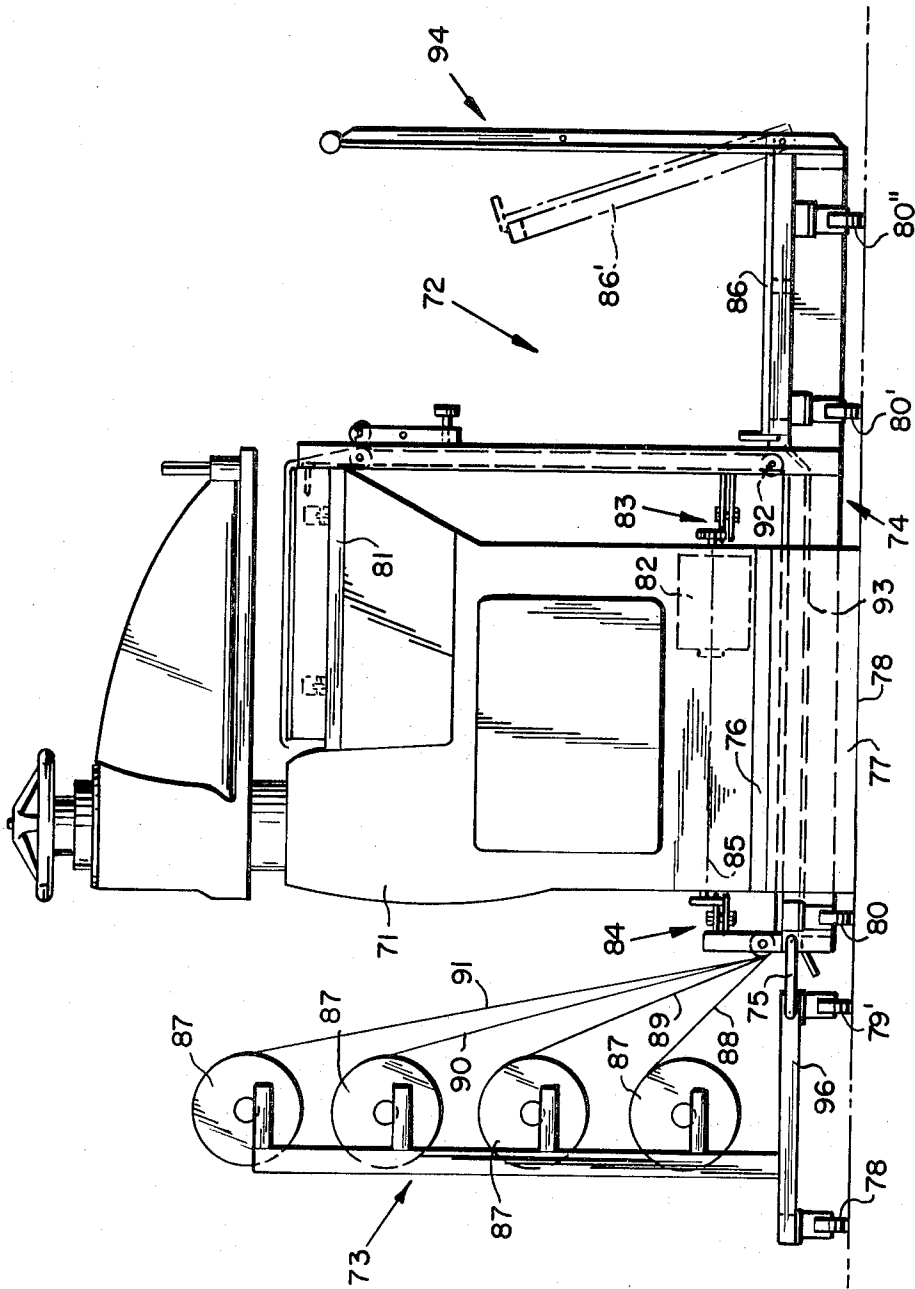

FIG.5

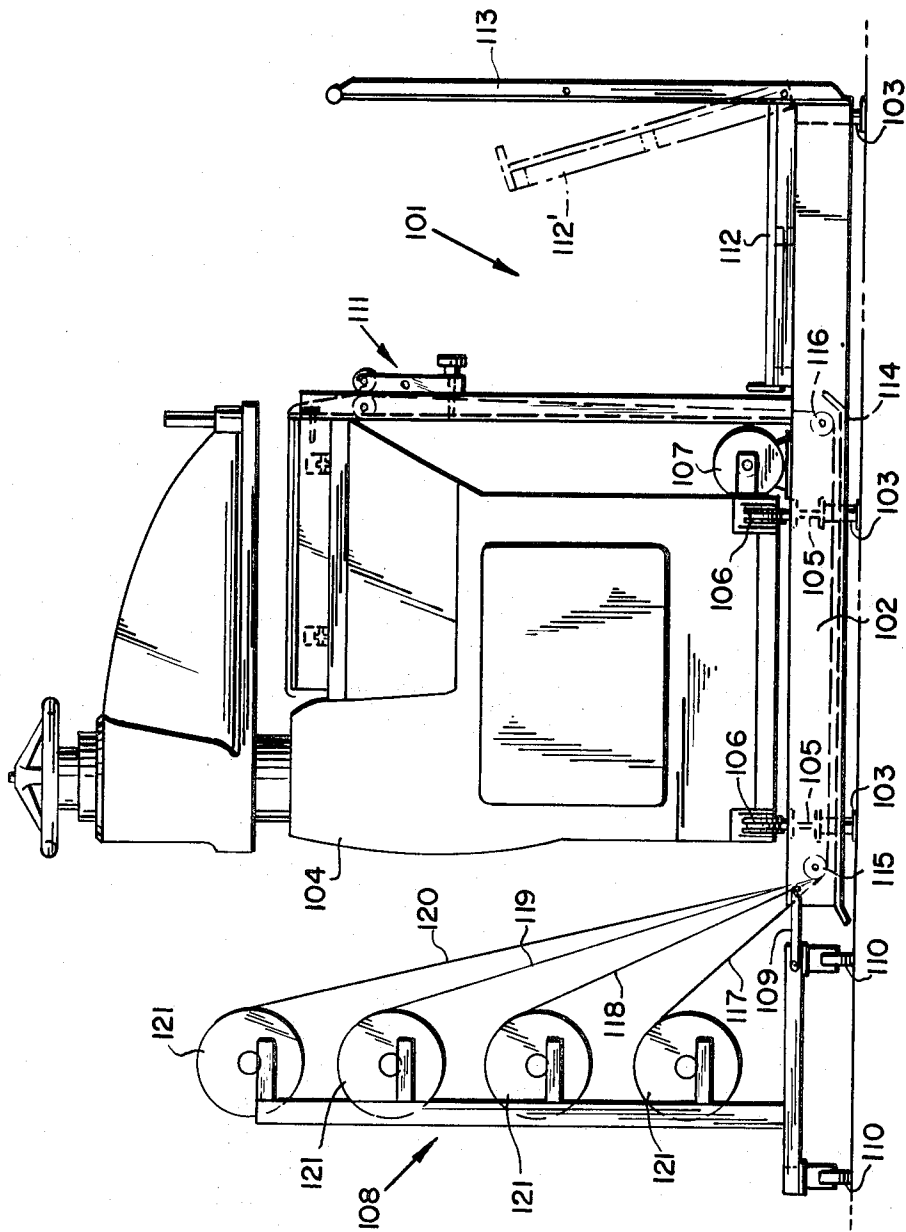

FIG.6

APPARATUS FOR PROCESSING SHEET MATERIAL

The invention relates to apparatus for processing sheet material, for example natural or simulated leather or textile material, the apparatus including cutting means, preferably a stamping machine having a pivotally mounted stamping arm.

Flat blanks are stamped out of natural leather, simulated leather or other plastics films and textile materials by means of stamping apparatus which permits economic operation. As regards leather, stamping apparatus with a pivotally mounted stamping arm has proved very satisfactory for some decades, because of good visibility of the material being processed and the consequent efficient use of material and ease of choosing the portions of material from which the desired blanks can be made. Owing to the increased use of simulated leather and other plastics materials, textile fabrics, etc supplied chiefly in the form of rolled-up webs, and the limited size of the stamping tables in pivoted arm stamping apparatus, the material processed has been cut approximately to table size and a plurality of layers have been processed simultaneously. This has resulted in a relatively high expenditure on work and high waste.

Pivoted arm stamping apparatus with larger stamping tables displaceable laterally beneath the arm were built to overcome these difficulties. A limited number of rolls of material, at most one or two rolls for reasons of space and to permit operation, can be suspended behind or on the front of these stamping tables. The number of layers is therefore limited to one or two although a larger number could usually be stamped from the material, which is substantially homogeneous over its entire area. The efficiency of a work station of this kind is therefore relatively low, and it has so far been impossible to accommodate large diameter rolls, for example of materials such as simulated fur linings, felt, foam material, etc owing to the shortage of available space in the vicinity of the machines.

Portal-type stamping machines, however, can process a plurality of layers of this type of material supplied directly off rolls. Unfortunately these machines are relatively bulky, expensive and suitable primarily for large batch production, whereas pivoted arm stamping machines, being relatively compact and cheaper, are better suited to small and medium sized batches of blanks.

An object of the invention is therefore to provide apparatus which permits a traditional, preferably pivoted arm stamping, apparatus to process a larger number of layers of sheet material from rolls than hitherto.

According to the invention, apparatus for processing sheet material comprises cutting means which are operative to cut the material and which comprises an elongated longitudinally extending bed on which the material is supported during cutting, material supplying means which are movable within end limits relatively to the cutting means in a longitudinal direction and which include first driving means for effecting longitudinal movement of the material supplying means, second driving means for feeding the sheet material towards the cutting means and deflecting and guiding means for passing the material towards the cutting means, and a carrier for supporting rolls of sheet material to be pro-

cessed, the carrier being coupled to the material supplying means.

Three embodiments of the invention will now be described, by way of example, with reference to the drawings, in which:

FIG. 1 is a side view of apparatus representing the first embodiment, looking in the direction of advance of material supplying means of the apparatus,

FIG. 2 is a front view of the apparatus of FIG. 1, looking in the direction of the arrow II in FIG. 1, the supplying means being shown in full lines in its left-hand limit position and in broken lines in its right-hand limit position,

FIG. 3 is a perspective detail view showing the drive for the material,

FIG. 4 is a perspective detail of the mounting for the material supply rolls, as seen from the operating side,

FIG. 5 is a stamping machine having a pivotally mounted stamping arm with a second embodiment of a material supply device movable with respect to the stamping machine, represented in a view similar to that of FIG. 1, and

FIG. 6 is an embodiment in which the material supply device is secured to the floor and the stamping machine with its pivotally mounted arm is arranged to be movable with regard to the device, shown in a view similar to that of FIG. 5.

FIG. 1 shows a stamping machine 1 with a pivoted arm 2 which can be adjusted in height by means of a handwheel 3 and swung manually about a vertical column 5 by means of a handle 4. The bottom portion of the stamping machine 1 rests on a plinth 6, which preferably completely surrounds the machine base, and has a stamping table 7 normally serving to support a somewhat resilient baseplate suitable for the material being stamped.

The supply apparatus 11 consists essentially of material supplying means 12 which are displaceable along the operator's side of the stamping machine 11 within a given range, and a portion coupled to the material supply means 12 and designated the material roll carrier 13.

The material supplying means 12 comprise a base frame 14, which is displaceable along the operator's side of the stamping machine 1 on rollers 15, either on a preferably flat runway 16 with or without guiding elements, or on a track arrangement (not shown). A carrying frame 17 standing substantially vertically at the front of the stamping machine 1 is mounted on the base frame 14. The carrying frame consists essentially of two lateral columns 18 connected at their tops to a table top 19, which is supported on the stamping table 7 of the machine 1 by means of resilient rollers 20. The table top 19 can therefore move longitudinally over the stamping table 7 when the base frame 14 moves longitudinally over the runway 16. The table top 19 is at least as long as the width of the sheet or web material being processed and at least as wide as the maximum radius of the arm 2.

The longitudinal motion of the base frame 14 relative to the stamping machine is produced by a drive unit comprising a geared motor 21 (shown in broken lines in FIG. 1) which is mounted on the plinth 6 and which, by way of a sprocket 22, drives a chain (not shown) supported by chain carrying members (also not shown), of which one stringer engages with the sprocket wheel 22 and the other is connected to driving

means 23 mounted on the base frame 14. The maximum travel of the table top 19 may be limited in a known manner by limit switch means and depends on the width of the web material being processed by the stamping machine.

As the detail in FIG. 3 shows for the mounting on the right-hand side, the carrying frame 17 has a roller arrangement generally designated 24, a simple form of which is shown in FIGS. 1 and 3. A bearing 25 mounted on the carrying frame columns 18 on each side of the base frame 14 supports the shaft 26 of a rear roller 27 which has a driving device, in this case a cranked handle 28. Alternatively, of course, the shaft 26 may be driven by a geared motor or similar device. Substantially level with the rear roller 27 there is a front roller 29, the end 30 of whose shaft is mounted in a U-shaped slot in the upper end of a pivotable upright 31, to facilitate removal of the roller 29. The upright 31 is pivoted on the carrying column 18 by means of a pivot bearing 32 and cooperates with a set-screw 34, which acts on a plate 33 fixed to the column 18, to urge the front roller 29 on to the rear roller 27. This feature serves, as described in detail below, to clamp the web material between the rollers 27, 29 so that it can be fed forwards by the driven roller 27. Identically or similarly equipped pivotable arms may of course be provided for the rear roller 27 (in a manner not shown in FIGS. 1 and 3) and — in respect to the column on the opposite side of the carrying frame 17 from the column 18 — for the front roller. Some other clamping member may be substituted for the setscrew 34, for example a spring operated by a toggle lever. Also, some other method and means may be used to urge the front roller 29 on to the rear roller in order to engage the layers of web material clamped between them.

A tilting frame structure 36 mounted above the base frame 14 has a cover 35 forming an access platform and bears deflecting rollers 37, 38 along its longer sides. The structure 36 can be tilted as indicated by dotted lines in FIG. 1, about an axis which may coincide with that of the deflecting roller 38. The frame structure 36 and deflecting roller 38 are preferably supported on a single shaft (not shown) mounted in the base frame 14. A toggle locking lever 39 is provided to keep the structure 36 in its upper position. The cover 35 is approximately as far from the floor or runway 16 as the plinth 6 below the stamping machine, and it forms a platform on which the machine operator stands. Preferably, covering means (not shown) are provided below the platform 35 to keep dirt off the web of material passing below it, as mentioned hereinafter. Similarly, covering and supporting means 40 are provided between the base frame 14 and the structure 36, to prevent sagging web material from touching the floor or runway 16.

The material roll carrier 13, comprising a carriage generally designated 42 connected to the base frame 14 by releasable bars 41, is connected to the material supply means 12 and is longitudinally movable therewith. The carriage has a chassis 44 which is supported on rollers 43 and which in turn carries supporting means 45 spaced from one another in the direction of advance of the carrier 13 over a distance corresponding to the maximum width of the rolls of material expected for processing. The supporting means 45 are provided with brackets 46 (four in the embodiment shown in FIGS. 1 and 2) which carry the bearing systems for the shafts

centring the rolls of material. FIG. 4 shows an embodiment of one of these bearing systems.

FIG. 4 shows a beam 47 carrying, as the supporting means 46, the above-mentioned brackets in the form of flat-section angle brackets welded to the beam 47. Rollers 50 (omitted from FIGS. 1 and 2 for the sake of clarity) mounted for example in ball bearings on the bracket 46 provide a rotary mounting for the shaft 49 supporting each roll 48 of material. The shaft 49 is held on the running surfaces of the rollers 50 by means of a swing lever 51, movable about a pivot 52 on the beam 47. This swing lever may have a friction covering (not shown) on its underside in the vicinity of the shaft 49, and it is preferably clamped on to the shaft 49 by easily and rapidly releasable clamping means. To this end a bolt 53 (FIG. 4) which can swivel anticlockwise and is movably mounted at its bottom end on the bent end portion of the bracket 46, can be slid sideways into a slot on the outer end of the swing lever 51. A wingnut placed on the bolt 53 enables the swing lever 51 to be urged on to the shaft 49 to a chosen degree.

Although the material roll carrier shown in FIGS. 1 and 2 is designed to take four supply rolls 48, the roll carrier may of course take more or fewer rolls of material. Also, the supporting means need not be simple uprights or brackets as illustrated.

If the supply rolls are initially very heavy, the shaft receiving means (FIG. 4) may advantageously be provided with a driving device, which either acts on one or both rollers 50 or is coupled directly to the shaft 49, in order to drive the rolls 48 when the web material is drawn forward (see below). This drive may be such that the various rolls can be driven at the same or different speeds.

Operation of the apparatus is as follows. First the required or maximum possible number of rolls 48 of the same or different materials, preferably of equal widths, are placed on the roll carrier 13. The pivoting structure 36 is tilted up, and the front roller 29 of the feed roller system 24 is removed. The beginnings of the webs of material, starting with the bottom roll, are then drawn out. The webs 54 to 57 of material are first placed loosely round the deflecting roller 38 and are then drawn substantially along the chain-dotted line 58 over the front edge 59 of the table top 19. When all the webs of material have been passed round the deflecting roller 38 in this way, they are preferably gripped together by lowering the arm 2 or by some other suitable means. Then two operations are possible: either the front roller 29 is replaced and pressed on to the rear, rigidly mounted roller 27, and the group of webs is made to run as indicated by the chain-dotted line 60 so that the individual webs 54 to 57 are fairly taut, whereupon the tilting structure 36 is tilted back into its horizontal position; or the tilting structure 36 can be folded down before the front roller 29 is replaced and pressed on, and the front roller 29 can be brought into the position shown in FIG. 1 afterwards. In either case, additional web material is drawn off the rolls 48, and the group of webs subsequently follows a path indicated by a solid line 61. The operator can now mount the access platform 35, and once he has lifted the arm 2 off the webs, repositioned the group of webs ready for work by means of the drive 28 acting on the rear roller, and if necessary shifted the table top 19 into its starting position, he can begin work with the stamping machine. As the work progresses, the operator shifts the table top

along with a suitable control, preferably a press-button control 62 (FIG. 2), acting on the motor 21.

Solid lines in FIG. 2 show the material supply means 12 and roll carrier 13 in a position corresponding to the beginning of work on the right of the web. The webs have been omitted for the sake of clarity. The supply means 12 and the roll carrier 13 can be displaced in the direction of an arrow V in accordance with the progress of the work or however desired. A fragmentary view in broken lines on the right in FIG. 2, omitting unnecessary details, shows the right-hand limit position, in which work can be carried out on the left-hand part of the web.

In FIG. 5 the pivoted arm stamping machine 71, is associated with material supply means 72 on the operating side of the stamping machine 71, and a material roll carrier 73. These two elements are interconnected by a releasable bar 75 and a connecting portion 74 which is partly shown in broken lines and which traverses a space beneath or in the lower part of the base of the stamping machine 1. In the embodiment shown in FIG. 5 the foot 76 of the stamping machine 71 stands on a plinth 77 defining the space.

In this embodiment also the material supply means 72 and the material roll carrier 73 can move on rollers 79, 79', 80, 80', 80'' along the machine table 81 relative to the stamping machine 71, which is fixed in position on the machine room floor 78. The rollers may run either on the floor 78 or on rails (not shown). The supply means are driven by a motor 82 fixed to the machine base, in the same way as described with reference to FIG. 1. This motor may drive the supply means by way of a chain driving device. FIG. 5 shows two systems 83 and 84 for this device; these systems may have the same basic construction as the corresponding system in FIG. 1. The system 84 is connected to the motor by a shaft 85 (illustrated diagrammatically) and serves primarily to ensure exactly parallel motion of the positions of the supply means in front of and behind the stamping machine. The system 84 might, of course, act on the roll carrier 73 instead of the connecting portion 74.

Both the supply means and the roll carrier 73 may be of substantially the same construction as was described with reference to FIG. 1. For example, the access platform 86, 86' may fold up in the same way, as shown by broken lines, to make it easier to draw the webs of material 88 to 91 off the rolls 87 into the space below the machine foot 76 and to pass the material round the deflecting roller 92. A covering element 93 is provided to prevent the material from touching the floor of the machine room. To protect the operator, a guardrail 94 may be provided on the side of the access platform 86 adjacent the machine room. The deflecting roller 95 on the roller carrier side may of course be mounted on the chassis 96 instead of near the driving means 84. The connecting portion 74 may be overhung in order to make it extend through the space below the stamping machine, in which case the rollers 80 are not required.

FIG. 6 illustrates a variant in which the material supply means generally designated 101 and the connecting portion 102 passing beneath the stamping machine are supported permanently on the machine room floor by means of bearing elements 103, whereas the pivoted arm stamping machine 104 can move, relative to the supply means, on rollers 106 supported on bearing rails 105. The reciprocating motion of the stamping machine is produced by a motor 107 which produces rela-

tive motion between the stamping machine and the supply means, and which may be rigidly mounted either on the supply means (as illustrated) or on the stamping machine.

The material roll carrier, designated 108 in FIG. 6, may be coupled to the connecting portion 102 by means of a bar 109 and be displaceable on rollers 110 as illustrated. Alternatively, it too may be supported permanently on the machine room floor by means of bearing elements (not shown).

The remaining part of the supply means, particularly the material feed apparatus 111, the access platform 112, 112' the guardrail 113 and the covering element 114 which prevents the webs 117 to 120 of material for processing (drawn off the supply rolls 121 and running over the deflecting rollers 115, 116) from touching the floor below, may be fundamentally the same as or similar to those described with reference to FIG. 1 or 5. Similarly, the control for the longitudinal movement of the stamping machine may be similar or substantially the same in design as in the embodiment shown in FIG. 1, in which the material supply means are movable instead of the stamping machine.

I claim:

1. An apparatus for processing sheet material, comprising in combination, a stationary cutting means which is operative to cut portions of sheet material and which comprises an elongated longitudinally extending bed on which the sheet material is supported during cutting; sheet material supplying means which is movable within end limits relatively to the cutting means in a longitudinal direction and which include first driving means for effecting longitudinal movement of the material supplying means, second driving means for feeding the sheet material towards the cutting means, and deflecting and guiding means for passing the material towards the cutting means; a carrier for supporting rolls of sheet material to be processed, said carrier being coupled to the material supplying means; and wherein the material supplying means comprises a substantially horizontal base frame and a substantially vertical carrying frame mounted on the base frame, the base frame including at least part of the deflecting and guiding means for the sheet material to be processed, said carrying frame including at least part of the second driving means for feeding the material.

2. The apparatus of claim 1 wherein rollers are mounted on the substantially horizontal base frame of the supplying means for movement along a runway.

3. The apparatus of claim 1 wherein the first driving elements comprise a driving motor and a drive sprocket and the second driving elements comprise a chain which is connected to the material supplying means and which meshes with the sprocket.

4. The apparatus of claim 1 wherein a table top mounted on the carrying frame is movable above the bed and is at least as long as the width of the material to be processed and at least as wide as the maximum radius of a pivotally mounted stamping arm positioned above the bed.

5. The apparatus of claim 1 wherein said guide means includes a tilting structure mounted on the base frame and carries an access platform supported on the base frame.

6. The apparatus of claim 1 wherein said carrier is a carriage having rollers disposed for movement on a runway.

7. The apparatus of claim 1 wherein said carrier is coupled to said material supplying means by coupling means.

* * * * *