

N. SVENSON.
THILL COUPLING.

APPLICATION FILED SEPT. 11, 1902.

NO MODEL.

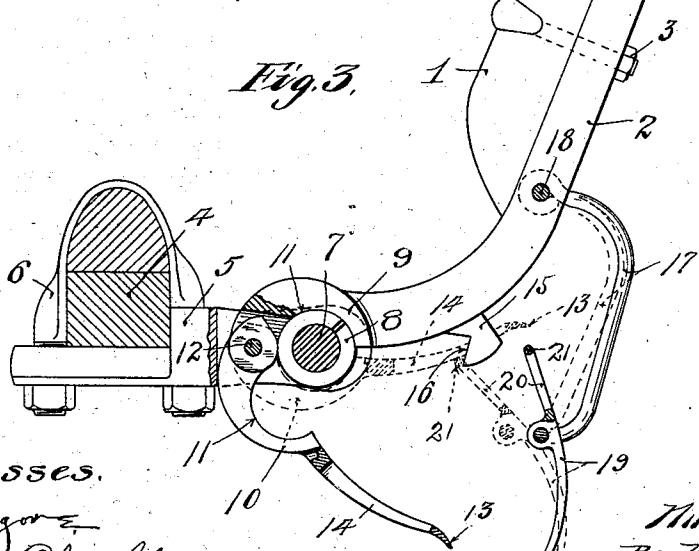
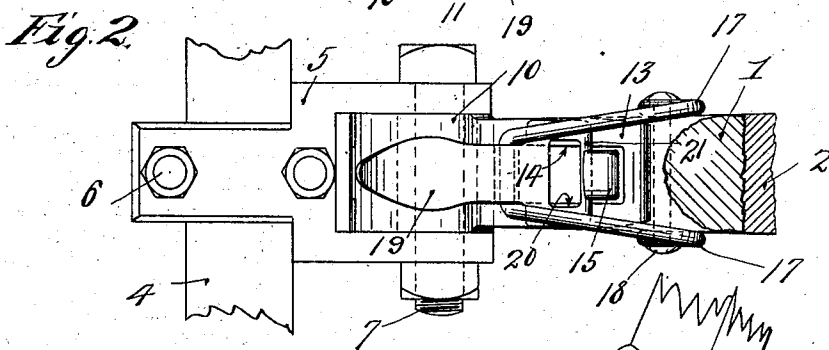
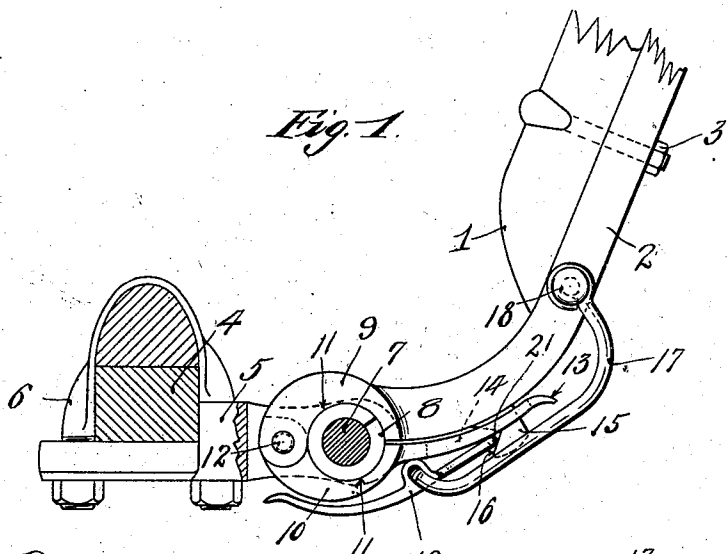

Witnesses.
H. D. Kilgore
A. B. Opsahl

Inventor:
Nils Svenson.
By his Attorneys,

Williamson Merchaud

UNITED STATES PATENT OFFICE.

NILS SVENSON, OF EXCELSIOR, MINNESOTA.

THILL-COUPLING.

SPECIFICATION forming part of Letters Patent No. 726,202, dated April 21, 1903.

Application filed September 11, 1902. Serial No. 122,946. (No model.)

To all whom it may concern:

Be it known that I, NILS SVENSON, a citizen of the United States, residing at Excelsior, in the county of Hennepin and State of Minnesota, have invented certain new and useful Improvements in Thill-Couplings; and I do hereby declare the following to be a full, clear, and exact description of the invention, such as will enable others skilled in the art to which it appertains to make and use the same.

My present invention relates to thill and pole couplings, and has for its object to improve the same in the several particulars hereinafter noted.

To such ends the invention consists of the novel devices and combinations of devices hereinafter described, and defined in the claims.

The invention is illustrated in the accompanying drawings, wherein like characters indicate like parts throughout the several views.

Figure 1 is a view in side elevation, with some parts broken away and some sectioned, showing a portion of a pair of thills coupled to the axle of a vehicle by one of my improved couplings. Fig. 2 is a bottom plan view of the device with the parts positioned as shown in Fig. 1; and Fig. 3 is a view corresponding to Fig. 1, but showing the clamping-jaw of the coupling released and thrown into an inoperative position.

The numeral 1 indicates one shaft of a pair of thills, to which, as is ordinary, one of the metal straps 2 is rigidly secured by nutted bolt 3 or otherwise.

The numeral 4 indicates the front axle of a vehicle, to which, as shown, ordinary coupling-brackets 5 are secured by means of clips 6 or other suitable devices. Through the prongs of each coupling-bracket 5 is passed a coupling-bolt 7, and, as shown, a split bushing 8, of leather, rubber, or other pliable material, is placed directly around the said bolt.

The coupling comprises a pair of jaws 9 and 10, the former of which is preferably integral with the strap 2 and both of which are provided with semicylindrical seats 11, which fit the bushing 8. The said jaws 9 and 10 are pivotally connected at 12, and the jaw 10, which is the relatively movable member, is provided with a tailpiece 13, with slot or per-

foration 14, through which a lock-lug 15 on the member 9 passes when the coupling is applied in working position and the jaws thereof clamped together. The lock-lug 15 is notched or undercut at 16, the said notch preferably being V-shaped. At any rate the lower surface of said notch should be inclined, so that it will act as a cam, as will be hereinafter described. A two-pronged spring-link of yoke 17 is pivoted to the coupling member 9 at 18, and on its free end is pivoted a lock-lever 19, provided at its inner end with a perforation 20, which leaves but a narrow transverse bar portion 21 at the extreme inner end of said lever.

The relations of the above-noted parts are such that they coact as follows: The coupling is first applied as shown by full lines in Fig. 3. Then the pivoted jaw 10 is swung upward, as indicated by dotted lines. Next the bar portion 21 of the lock-lever 19 is placed against the tail 13 of the jaw 10 and against the depending inclined or cam surface 16 of the lock-lug 15. Then next and finally the lock-lever 19 is turned upward and toward the left into its locking position, (indicated by full lines in Fig. 1,) in which position, it will be noted, the pivoted free end of the spring-link 17 is moved upward beyond a dead-center or above a line drawn through the pivot 18 and the point of engagement of the bar portion 21 with the lock-lug 15. Hence, of course, the said lock-lever is yieldingly but securely held in its locking position. The jaws or members 9 and 10 are not, however, yieldingly locked together, but are positively locked by the bar portion 21 of the lock-lever, which is interposed between the tail of the jaw 10 and the undercut or cam surface of the lock-lug 15. Hence there is no danger whatever of the coupling becoming accidentally detached. At the same time it may be quickly detached by forcing the free end of the lock-lever 19 downward and toward the right, so as to throw the parts back into the position indicated by full lines in Fig. 3.

It will of course be understood that the device described is capable of modification within the scope of my invention as herein set forth and claimed.

What I claim, and desire to secure by Letters Patent of the United States, is as follows:

1. In a coupling for thills, poles, &c., the combination with a pair of jaws connected for pivotal movements, one thereof having a notched lock-lug and the other having a tail portion coöperating therewith, of a link pivoted to the member having said lock-lug, and a lock-lever pivoted to said link and engageable at one end with the notch of said lock-lug and with the tail of the movable jaw, to positively lock the said jaws together, substantially as described.

2. In a coupling for thills, poles, &c., the combination with the jaws 9 and 10 pivoted at 12, said jaw 9 having the lock-lug 15, notched or undercut at 16, and said jaw 10

having the tail 13 perforated at 14 to pass said lug 15, the spring-link 17 pivoted to said jaw 9, and the lock-lever 19 pivoted to the free end of said link 17 and provided at its inner end with the transverse portion 21 engageable with the surface 16 of said lug 15 and with the tail 13 on said jaw 10, the said parts coöperating to positively lock said jaws together, substantially as described.

In testimony whereof I affix my signature in presence of two witnesses.

NILS SVENSON.

Witnesses:

A. H. OPSAHL,
F. D. MERCHANT.