

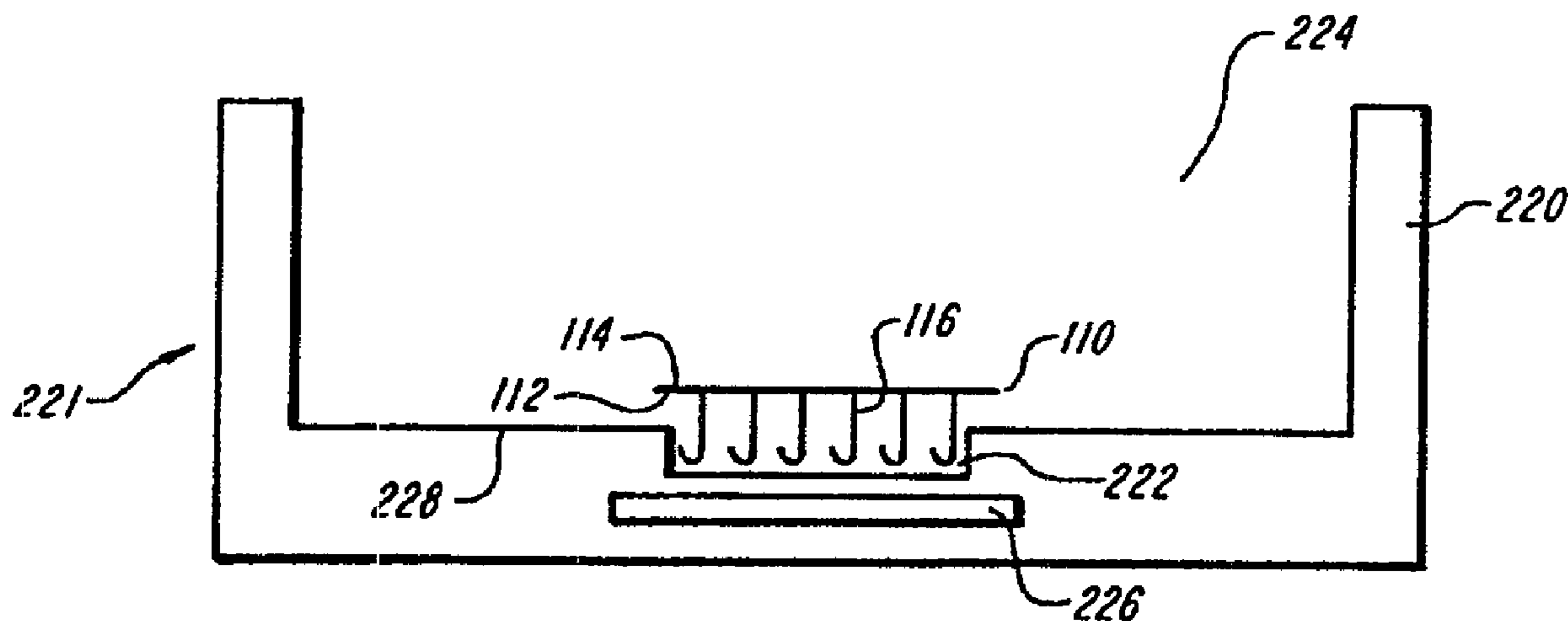

(86) Date de dépôt PCT/PCT Filing Date: 1996/02/16
 (87) Date publication PCT/PCT Publication Date: 1996/08/22
 (45) Date de délivrance/Issue Date: 2007/05/29
 (85) Entrée phase nationale/National Entry: 1997/08/05
 (86) N° demande PCT/PCT Application No.: IB 1996/000394
 (87) N° publication PCT/PCT Publication No.: 1996/025064
 (30) Priorité/Priority: 1995/02/17 (US08/390,876)

(51) Cl.Int./Int.Cl. *A44B 18/00* (2006.01),
B29C 33/16 (2006.01), *B29C 47/06* (2006.01),
B29C 47/34 (2006.01)
 (72) Inventeurs/Inventors:
 JACOBS, MARTIN I., US;
 KENNEY, RANDALL B., US;
 ROUTHIER, BRIAN J., US
 (73) Propriétaire/Owner:
 VELCRO INDUSTRIES B.V., AN
 (74) Agent: SMART & BIGGAR

(54) Titre : ATTACHE PAR CONTACT AVEC PARTIE D'ATTRACTION MAGNETIQUE
 (54) Title: TOUCH FASTENER WITH MAGNETIC ATTRACTANT



(57) Abrégé/Abstract:

A fastening component of a separable fastener has some portion that is necessary for its fastening function, such as the hooks, the base to which the hooks are attached or a substrate that is used for another purpose, comprised of a magnetically attractive constituent. Another portion of the fastening component is comprised of a magnetically inert constituent. The fastening element may be the hook portion or the loop portion of a typical fastener. The fastening elements and the base may be unitary, or of different precursors, such as in a woven fastener component. The magnetically inert constituent may comprise a polymeric plastic or a thermoplastic elastomer. The magnetic attractant may impregnate the magnetically inert constituent, or it may coat or be coated by the magnetically inert constituent. The magnetic attractant may comprise a metal powder. The metal may be selected from the group consisting of iron powder. The magnetic attractant may be an organo-iron or a rare earth metal. In a woven fastener, either the base structure or the hooks may include the magnetic attractant, or both may do so. The material that forms the hooks may be entirely of a magnetically attractive material, with the material that forms the woven base being magnetically inert. Rather than the magnetically attractive material being incorporated into the fastening elements or the base, it may be incorporated into the substrate that is formed from a precursor element that is separate from the base, and that is joined to the base.

PCT

WORLD INTELLECTUAL PROPERTY ORGANIZATION
International Bureau

INTERNATIONAL APPLICATION PUBLISHED UNDER THE PATENT COOPERATION TREATY (PCT)

<p>(51) International Patent Classification ⁶ : A44B 18/00, B29C 33/16</p>	A3	<p>(11) International Publication Number: WO 96/25064 (43) International Publication Date: 22 August 1996 (22.08.96)</p>
<p>(21) International Application Number: PCT/IB96/00394 (22) International Filing Date: 16 February 1996 (16.02.96) (30) Priority Data: 08/390,876 17 February 1995 (17.02.95) US (71) Applicant: VELCRO INDUSTRIES B.V. [NL/NL]; Castorweg 22-24, Curacao (AN). (71)(72) Applicant and Inventor (for all designated States except CA CN JP KR MX): JACOBS, Martin, I. [US/US]; 40 Brick Mill Road, Bedford, NH 03110 (US). (72) Inventors: KENNEY, Randall, B.; 35 Mountain Road, Con- cord, NH 03301 (US). ROUTHIER, Brian, J.; 109 A Wirt Street S.W., Leesburg, VA 22075 (US). (74) Agent: WEISSBURG, Steven, J.; Suite 303, 238 Main Street, Cambridge, MA 02142 (US).</p>	<p>(81) Designated States: CA, CN, JP, KR, MX, European patent (AT, BE, CH, DE, DK, ES, FR, GB, GR, IE, IT, LU, MC, NL, PT, SE). Published <i>With international search report. Before the expiration of the time limit for amending the claims and to be republished in the event of the receipt of amendments.</i> (88) Date of publication of the international search report: 26 September 1996 (26.09.96)</p>	

(54) Title: TOUCH FASTENER WITH MAGNETIC ATTRACTANT

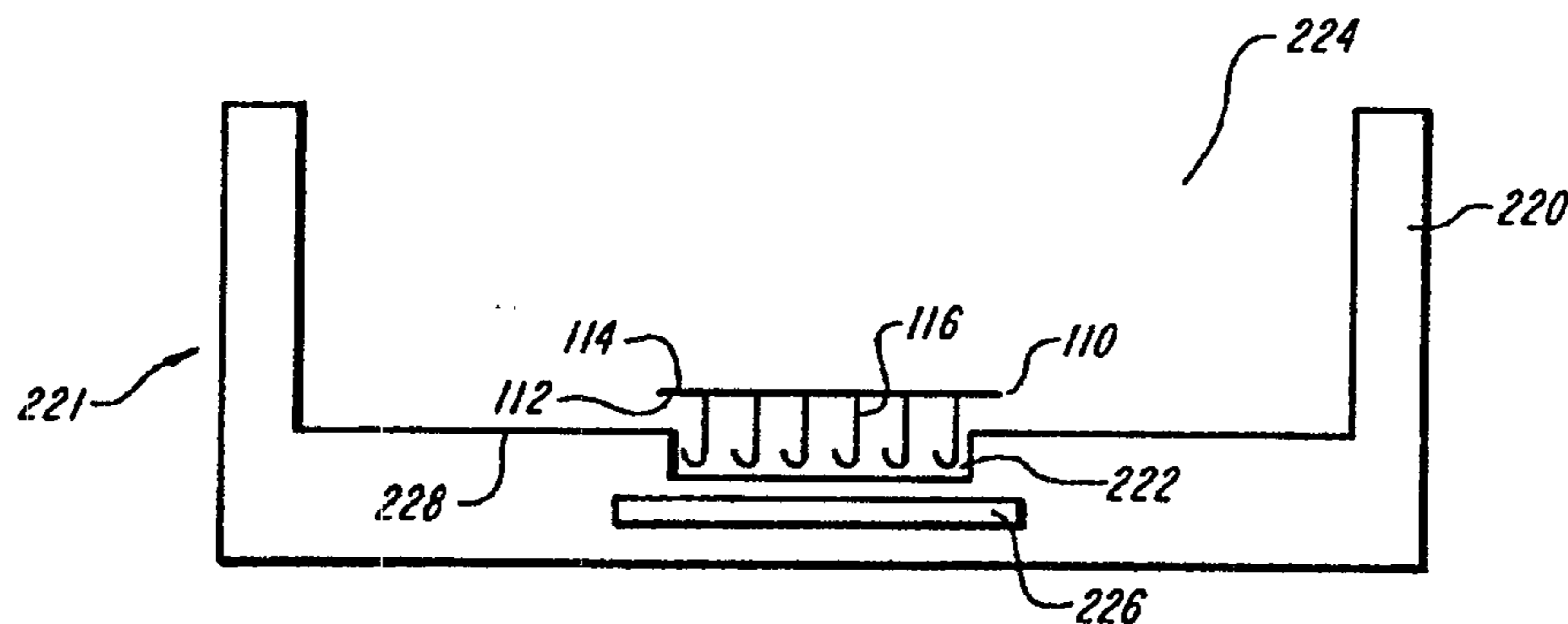

(57) Abstract

A fastening component of a separable fastener has some portion that is necessary for its fastening function, such as the hooks, the base to which the hooks are attached or a substrate that is used for another purpose, comprised of a magnetically attractive constituent. Another portion of the fastening component is comprised of a magnetically inert constituent. The fastening element may be the hook portion or the loop portion of a typical fastener. The fastening elements and the base may be unitary, or of different precursors, such as in a woven fastener component. The magnetically inert constituent may comprise a polymeric plastic or a thermoplastic elastomer. The magnetic attractant may impregnate the magnetically inert constituent, or it may coat or be coated by the magnetically inert constituent. The magnetic attractant may comprise a metal powder. The metal may be selected from the group consisting of iron powder. The magnetic attractant may be an organo-iron or a rare earth metal. In a woven fastener, either the base structure or the hooks may include the magnetic attractant, or both may do so. The material that forms the hooks may be entirely of a magnetically attractive material, with the material that forms the woven base being magnetically inert. Rather than the magnetically attractive material being incorporated into the fastening elements or the base, it may be incorporated into the substrate that is formed from a precursor element that is separate from the base, and that is joined to the base.

TOUCH FASTENER WITH MAGNETIC ATTRACTANT

5

BACKGROUND

The present invention relates to touch fasteners in general, and more specifically, to touch fasteners for incorporation by molding into molded articles.

Hook and loop type separable touch fasteners, such as those sold by the assignee of this application under the trademark Velcro, are well-known and are used to join two members detachably to each other. This type of fastener has two components. Each has a flexible substrate material having one component of the fastening system on a fastening surface thereof. One component is typically comprised of resilient hooks while the other is comprised of loops, and when the two surfaces are pressed together they interlock to form a releasable engagement.

Separable fasteners are used in the manufacture of automobile seats in the attachment of an upholstered seat cover to a polyurethane foam bun. One portion of the separable fastener is incorporated onto the surface of the polyurethane foam bun during the foam molding process. The mating portion of the separable fastener is attached to the seat cover to provide releasable attachment to the foam bun. The separable fastener assembly used in the foam mold for incorporation in the bun surface typically comprises the hooked portion of a separable fastener. This hook portion is characterized by a base carrying resilient hooks on a fastening surface. The opposite, non-fastening surface of the base may carry anchor projections to become incorporated into the foam to provide stable attachment of the separable fastener assembly to the foam article. It is also common

for a backing layer or substrate to mate with the non-
fastening face of the base. The substrate may be of a
material that is more conducive to handling, of the
component or its adherence to other articles. Anchor
5 projections may also project from the substrate. Further,
other components can be sandwiched between the substrate and
the base.

A protective layer, such as a thin plastic film, may be
placed over the resilient hooks, to prevent incursion of
10 foam into the hooks during the molding process, since
significant foam contamination of the hooks would affect
their ability to engage with the mating portion of the
fastener attached to the seat cover. Alternatively, an
elastomeric cover that intimately surrounds the hooks,
15 except for a small portion at their tips, can also be used.
After the molded article is fabricated and removed from the
mold, the elastomeric material is removed.

In some assemblies, a magnetically attractive shim is
attached to the base to facilitate placement of the assembly
20 in a valley (also known as a trench or trough) of the mold
cavity wall, which is equipped with magnets. The shim also
helps secure the hook-carrying face of the component tightly
against the mold wall, thereby further minimizing incursion
of the foam into the hooks. The assemblies may be referred
25 to as "mold-in" fasteners or assemblies, due to their use in
such molded products.

The shim can be incorporated into different locations
in the assembly. It can be sandwiched between the hook
carrying base and a substrate or backing layer, either
30 temporary or permanent. It can be located centrally
relative to the width of the hook-carrying base, or along
its marginal edges. In cases where a thin plastic film is
used to cover the hooks, the shim can be sandwiched between
the plastic sheet and the hooks.

As mentioned above, it is also known to substantially cover the hook region with an elastomeric material that protects the hooks against incursion of the foam. It is known to include a magnetic attractant in this elastomeric material.

Known methods of adhering the protective film cover to the hook-carrying component include to use a long bead of hot melt adhesive there between. It is also known to include a magnetic attractant in this hot melt material.

The known methods all have drawbacks. With regard to the metal shim itself, it presents an extra component and an extra manufacturing step, thereby contributing to the cost of the assembly and the time for manufacturing a given length of material. The metal shim also contributes to the weight of the material. In the construction process, care must be taken that workers are not cut by the metal strips. The metal limits the flexibility of the strip, and consideration must be taken of the thermal expansion and contraction properties of the various binders and additional layers that might be used to secure the strip to the substrate. The metal strip also curls and bows and generally makes handling the component unwieldy.

Considering those known assemblies that use either the protective plastic or the elastomeric cover to contain the metal shim, or a magnetic attractant, there are reasons to eliminate these protective covers, if possible. The protective covers also entail additional steps, in their manufacture, attachment to the fastener assembly, and removal from the fastener assembly after molding. All protective material must be removed from the hooks (or loops, if it be the loop carrying component molded into the article), or else the hooks (or loops) will not be exposed to fasten to the mating component. These extra steps must typically be conducted away from a normal high speed

production line and contribute to the cost of the fastener assembly, the time for its manufacture, and also generate a relatively large volume of essentially waste material. Additionally, sometimes a residue from the cover material
5 remains on the fastening component after removal, which is undesirable.

Thus, there is a great need for a touch fastener assembly that can be molded into a molded product, without the use of metal shims or protective covering for the
10 fastener components. There is also a need to simplify the manufacture of such mold-in assemblies, to minimize their cost, production time, and the time to prepare the molded product for use. It is thus an object of the invention to facilitate a simple means for providing a magnetic
15 attractability to the mold-in fastener assembly. It is another object of the invention to provide a light weight mold-in assembly that does not require a metal shim or protective covering for the fastener components, such as hooks.

20

SUMMARY

A preferred embodiment of the invention is a fastening component of a separable fastener, where some portion of the fastening component that is absolutely necessary for its fastening function, such as the hooks, the base to which the
25 hooks are attached or a substrate that is used for another purpose, is comprised of a magnetically attractive constituent, and where another portion of the fastening component is comprised of a magnetically inert constituent. Either the hook portion or the loop portion of a typical
30 fastener may include the magnetically attractive constituent.

A preferred embodiment of the invention is thus a component of a two component separable fastener, said

component comprising a base; and carried on said base, a plurality of fastening elements; wherein at least one of said base and said fastening elements comprise a magnetically inert constituent that is intimately associated
5 with a magnetic attractant constituent. The fastening elements and the base may be unitary, such as in the case of an extruded component, or they may be of different precursors, such as in the case of a woven fastener component.

10 The magnetically inert constituent may comprise a polymeric plastic or a thermoplastic elastomer, including but not limited to polypropylene, polyethylene, polyamide, polyester, polystyrene, polyvinyl chloride, acetal, acrylic, polycarbonate, polyphenylene oxide, polyurethane and
15 polysulfone.

The magnetic attractant may impregnate the magnetically inert constituent, or it may coat or be coated by the magnetically inert constituent.

The fastening elements may comprise hook-like elements
20 or loop-like elements.

The magnetic attractant may comprise a metal powder. The metal may be selected from the group consisting of iron powder, magnetite iron oxide, hematite iron oxide, iron(II) oxide, iron (III) oxide, iron(III) stearate. The magnetic
25 attractant may also be an organo-iron compound or a rare earth metal.

In the case of a woven fastener, either the base structure or the hooks may include the magnetic attractant, or both may do so. Further, the material that forms the
30 hooks may be entirely of a magnetically attractive material, with the material that forms the woven base may be magnetically inert.

The fastener may also include a substrate, that is formed from a precursor element that is separate from said base, and that is joined to said base. The fastening elements and the substrate may be coextruded or formed separately and laminated together. The substrate may be of a woven, non-woven, paper or foam material.

The fastening elements may comprise polymeric monofilaments.

Another preferred embodiment of the invention is a molded article comprising a body molded from a molding material, said body having at least one surface and an interior body region, fixed to said surface of said molded body, a separable fastener component for use with a complementary separable fastener component, said separable fastener component being according to any of the variations described above.

Another preferred embodiment of the invention is a component of a two component separable fastener, the component comprising a base and carried on the base, a plurality of fastening elements and, joined to the base, a substrate, where the substrate comprises a magnetically inert constituent that is intimately associated with a magnetic attractant constituent.

The magnetically inert constituent may be as described above, with respect to the embodiment where the magnetic attractant is associated with either the fastening elements or the base. The magnetically attractive constituent may also be any of the magnetically attractive materials identified above.

Yet another preferred embodiment of the invention is a method of making a component of a two component separable fastener, the method comprising the steps of providing a

60412-3486

magnetic attractant and associating said magnetic attractant with at least one of a base and a plurality of fastening elements carried on said base; wherein at least one of said base and said fastening elements comprise a magnetically
5 inert constituent that is intimately associated with said magnetic attractant.

The magnetic attractant may be associated with the base only, or the fastening elements only, or both. A polymeric plastic resin may be mixed with a magnetic attractant such
10 as identified above. The polymeric plastic resin may be such as is identified above.

According to still another preferred embodiment, the invention is a method for making a molded article, said method comprising the steps of making a component of a two
15 component separable fastener, such as identified above, having a magnetic attractant intimately associated therewith, according to the methods identified above. The fastening component is then placed into a mold, with its fastening face facing a wall of said mold, said mold
20 comprising: a fastening element receiving valley region and a magnet inside a mold wall adjacent said fastening element receiving valley, whereby said magnet attracts said fastener component toward said mold wall. Molding material is provided to said mold to mold the product with the fastening
25 component incorporated therein.

60412-3486

In accordance with a broad aspect of the present invention, there is provided a method of continuously forming a separable touch fastener strip having a flexible base unitarily molded with a plurality of fastening elements
5 extending from a fastening surface thereof, the method comprising: providing an apparatus having a cavity roller that contains cavities for forming the fastening elements, and a base roller which defines, together with the cavity roller, a nip; supplying a first stream of molten plastic to
10 the nip under conditions which cause the plastic of the first stream to fill the cavities of the cavity roller and form the fastening surface of the base; while supplying a second stream of molten plastic to the nip along with the first stream of molten plastic, such that plastic of the
15 first stream and plastic of the second stream are joined in the nip to form the fastener strip; allowing the formed fastener strip to travel around the cavity roller; and then passing the formed fastener strip around a stripping roller to pull the formed fastener strip from engagement with the
20 cavity roller.

BRIEF DESCRIPTION OF THE DRAWINGS

These and other features, aspects, and advantages of the present invention will become better understood with regard to the following description, appended claims and
25 accompanying drawings, where:

Fig. 1 is a schematic perspective view of a fastening component of the invention, where the fastening elements are hook-type elements.

5 Fig. 2 is a cross-sectional side view of a mold for use with the invention, having a cavity for insertion of the fastening component and a magnet within the mold walls, also showing a fastening component of the invention in place in the mold for molding.

10 Fig. 3 is a cross-sectional view similar to that shown in Fig. 2, where the mold-in product has hooks and anchors back-to-back.

Fig. 4 shows, schematically, the mold of Fig. 3, with molding material being poured into the mold.

15 Fig. 5 shows, schematically, the molding material curing in the mold shown in Fig. 4.

Fig. 6 shows, schematically, a molded product including a fastening component of the invention, either a single sided fastener, or an anchored back-to-back fastening component.

20 Fig. 7 shows schematically an apparatus and process for manufacturing an embodiment of the fastener component of the invention, having a unitary molded base carrying hooks on one surface thereof.

25 Fig. 8 shows schematically an apparatus and process for manufacturing an embodiment of the fastener component of the invention, having a substrate and hooks which are co-extruded and then laminated together.

30 Fig. 9 shows schematically a fastening component of the invention having a unitary molded base carrying hooks on one surface thereof, laminated with a separate substrate.

Fig. 10 shows schematically an apparatus and process for manufacturing an embodiment of the fastener component of the invention, having a unitary molded base carrying hooks on one surface thereof, which is further laminated with a substrate of a different material.

Fig. 11 shows schematically an embodiment of the invention, having a magnetically attractive loop carrying fastener component.

DETAILED DESCRIPTION

10 A fastening component 100 of the invention is shown schematically with reference to Fig. 1. A base 110 has two surfaces: a fastening surface 112 and a non-fastening surface 114. The base may be woven, non-woven, plastic, fabric or any other suitable structure or material. The invention is not limited to the mechanical form of the base, and any known mechanical form of base for separable touch-type fasteners is believed to be consistent with the invention. Often, the base is a plastic base and it is attached to a separate substrate of a different material.

15 If the base is a woven structure, the base portion may be referred to as a "ground fabric."

The base presents on its fastening surface 112, a plurality of hook-type elements 116. The hook-type elements may be shaped as hooks, or mushrooms or two tined anchors, or any other mechanical form of hook-type element used for separable touch-type fasteners, which engage loop-type elements, as is known in the art. Such elements are referred to herein as "hook-type", or "hook-like" or "hook" elements, whether or not they are in the shape of hooks.

25 Any known mechanical form, and any as yet unknown mechanical form of hook elements is believed to be consistent with the invention.

According to the present invention, either the fastening elements 116 (hooks, as shown in the figure) or the base 110, or both, include a magnetically attractive constituent. As shown in Fig. 2, the fastening component 5 100 is used in a mold 221, having a main mold wall 220 surrounding a main cavity 224. A fastening element-receiving mold valley 222 is in the bottom wall 228 of the mold. Embedded in the bottom wall 228 is a magnet 226, such as is known in the art.

10 The fastening component 100 is inserted into the mold, adjacent the fastening element-receiving valley 222, with the hooks 116 facing into the valley 222. The magnet 226 attracts the fastening component 100 toward the bottom mold wall 228, due to the magnetically attractive material 15 contained in the fastening component 100. The magnetic attraction secures the fastening component to the mold wall, thereby preventing the incursion of the molding material among the fastening elements.

In addition to the magnetic attractant, other 20 techniques can and are typically used to prevent the fouling of the fastening elements with the molding material. Any such structures known to the art, and any such structures yet to be developed, are believed to be consistent with the invention. For instance, a film strip can completely cover 25 the fastening elements, such as is shown in U.S. Patent No. 4,693,921, issued in 1987 to Billarant, entitled FASTENING TAPE DESIGNED TO BE ATTACHED TO A MOLDED ARTICLE DURING MOLDING, AND ITS ATTACHING METHOD. Rather than covering the entire surface of the fastening elements, strips of film can 30 border the fastening element region, forming gaskets to prevent the incursion of film. Such film regions are shown in U.S. Patent No. 4,726,975, issued in 1988 to Hatch, entitled METHOD AND APPARATUS FOR ADAPTING SEPARABLE FASTENERS FOR ATTACHMENT TO OTHER OBJECTS. Also possible is

60412-3486

to use an elastomeric covering that intimately (either completely, or partially) surrounds the fastening elements, such as is described in U.S. Patent No. 5,286,431 (for fully surrounding), issued to Banfield et al. in 1994, entitled
5 MOLDED PRODUCT HAVING INSERT MOLD-IN FASTENER or, (for partially surrounding) as shown in PCT application No. PCT/US94/07473 for HOOK AND LOOP TYPE INSERT USED IN MOLDING PROCESS, published January 19, 1995, corresponding to U.S. patent application Serial No. 08/087,917, filed on
10 July 6, 1993, issued as U.S. Patent No. 5,393,585 on February 28, 1995, now abandoned, entitled DIE CUT MOLD-IN.

Another possibility is to use a fastening component, for instance having hook-type fastening elements, that has a
15 pattern of hooks with a main central region, circumscribed by a bald region that is substantially free of hooks, which is itself circumscribed by a perimeter region of hooks. The fastening element is used with a mold having a central valley, surrounded by a perimeter land, which is in turn
20 typically surrounded by a perimeter valley. The perimeter valley mates with the perimeter region of hooks; the land mates with the bald region; and the central mold valley mates with the central main region of hooks. The perimeter region of hooks may be partially fouled by the incursion of
25 foam material, however, the main, central region of hooks is not fouled, being protected by the "sacrificial" perimeter hooks. Such an arrangement is described in assigned U.S. Patent No. 5,606,781 issued March 4, 1997. in the names of Brian J. Routhier, Martin I. Jacobs and
30 George A. Provost, entitled SEPARABLE FASTENER HAVING A BALD PERIMETER RIB BOUNDED BY FASTENING ELEMENTS.

The molding process is shown schematically in Figs. 3, 4, 5 and 6, for incorporating an embodiment of the fastener

of the invention that is a back-to-back hook and anchor fastener into a molded product. The fastener component 300 is inserted into the main cavity 324 of the mold 321, with its fastening elements 316 facing the fastening element receiving valley 322 and its anchoring elements 334 facing the central region of the main mold cavity 324. The magnet 326 attracts the fastening component 300 toward the magnet 326, thereby enhancing the sealing of the fastening component to the mold wall 328. This helps to prevent fouling of the hook components 316 during the molding process.

The next step in the molding process is shown schematically in Fig. 4, where the molding material 410 is introduced into the mold. The molding material may constitute a single component, or there may be multiple components that are mixed as they are introduced into the mold, or before.

The article being formed 524 is shown schematically in Fig. 5. The anchor elements 334 are surrounded by the molding material, thereby embedding the fastening component into the molded article. It is not necessary that anchoring elements be used, and there are many ways known to the art that do not use them. Fig. 5 is intended to show both anchored and unanchored embodiments. A molded article 524 incorporating the magnetically attractive fastening component 300 with exposed hook components 316 is shown schematically in Fig. 6. The optional anchoring elements 334 are shown in phantom, embedded in the molded material. A typical type of molded article is a foam seat cushion, such as for an automobile or airplane. Rather than foam, other types of molded materials are also suitable.

In a typical embodiment of the invention, the hook elements 116 and the base 110 are molded unitarily from the same precursor element as one mechanical element, and are

60412-3486

thus composed of the same material. Suitable such materials include: polymeric plastics such as: polypropylene, polyethylene, polyamide, polyester, polystyrene, polyvinyl chloride, acetal, acrylic, polycarbonate, polyphenylene oxide, polyurethane, polysulfone, and thermoplastic elastomers. Suitable magnetic attractants include: all ferro-magnetic materials, such as iron (powder), iron oxide (various forms, including magnetite, hematite, iron(II) oxide, iron (III) oxide), iron(III) stearate (and various organo-iron compounds), rare earth metals and their compounds.

An apparatus for molding a fastening component having unitarily molded fastening elements and base is shown schematically in Fig. 7. This apparatus is of the type shown generally in U.S. Patent Nos.: 4,794,028, entitled METHOD FOR CONTINUOUSLY PRODUCING A MULTI-HOOK FASTENER MEMBER AND PRODUCT OF THE METHOD, issued in 1988 to Fischer; 4,872,243, entitled MULTI-HOOK FASTENER MEMBER, issued in 1989 also to Fischer; and 4,775,310, entitled APPARATUS FOR MAKING A SEPARABLE FASTENER issued in 1988 also to Fischer. An extruder barrel 701 melts and forces molten plastic 703 through a die 702, into the nip 706 between a base roller 704 and a cavity roller 705, that contains cavities 711 to form the hooks 716 of a strip fastener 700, which extend from a web-like base 710 composed of the same material as is the hooks 716. The strip fastener material formed at the nip 706 travels around the periphery of the cavity roller 705 and around the stripping roller 713, which assists in pulling the formed hook sheet from engagement with the cavity roll 705. The strip is then passed to a wind-up roll, not shown.

Examples

In a first example, molded hooks, of the type known as Velcro Ultra 8 brand hooks sold by Velcro Group corporation of Manchester, New Hampshire, were molded using the unitary continuous forming method, such as shown in Fig. 7, also described in the above cited U.S. Patents Nos. 4,794,028, 4,872,243 and 4,775,310 to Fischer. The material provided to the extruder was 40% (all percentages are by weight) Impet brand (polyethylene terephthalate PET) resin premixed with ferro-magnetic filler, sold by the Hoechst Celanese Company of Chatham, NJ., grade EKX - 155, blended with 60% Vandar brand (polybutylene terephthalate PBT) resin also sold by Hoechst grade MB90011A1. The processing temperatures ranged from 530°F in the feed section of the extruder to 570°F at the die. The temperature of the base roll was 104°F, the cavity roll 191 °F and the stripping roll was 83°F.

In a second example, molded hooks, of the same type, were again molded using the unitary continuous forming method such as shown in Fig. 7. The material provided to the extruder was 40% Celcon brand (acetal) resin with ferro-magnetic filler, sold by the Hoechst, grade MM3.5H blended with 60% Celcon brand (acetal) resin also sold by Hoechst, grade TX90 PLUS. The processing temperatures ranged from 360°F in the feed section of the extruder to 375°F at the die. The temperature of the base roll was 105°F, the cavity roll 195 °F and the stripping roll was 85°F.

It is also possible, as is well known, for the hook elements to be unitarily molded with a base and for a web-like substrate to be manufactured from separate mechanical precursor elements, which are subsequently or simultaneously joined. For instance, the hook elements with base and the substrate can be co-extruded according to any known method; such as by a cross-head die or by calendaring two separate

extrusion streams together. In such a case, either the hooks with base, or the substrate alone, or both together can include the magnetic attractant. They may be of identical materials, or different.

5 An apparatus for molding a fastening component having coextruded fastening elements with a base and a substrate is shown schematically in Fig. 8. This apparatus is similar to that shown above with reference to Fig. 7, but uses a cross-head die. Molten plastic 803h (for hooks and base) and 803s
10 (for substrate) is forced through a cross-head coextrusion die head 802, with two different die orifices 807h and 807s. The two streams of molten plastic are forced into the nip 806 between a base roller 804 and a cavity roller 805, that contains cavities 811 to form the hooks 816 of a strip
15 fastener 800. A pool of hot hook material P_h forms upstream of the nip, as well as a pool of hot second substrate material P_s . At the nip, the hook material is forced into the cavities 811 in the hook roller 805. Simultaneously, the substrate material is flattened and spread into a web
20 shape, along with a quantity of the hook material (which forms a base unitarily with the hooks being formed). The pressure in the nip joins the hook material and base, on the one hand, with the substrate material, on the other hand such that the hooks 816 and the substrate 830 are formed,
25 and joined to become the fastener component 800. This coextruded component travels around the hook roller 805, and is stripped therefrom in the same manner as is a simple extruded unitary hook and base component, shown in Fig. 7. The strip is then passed to a wind-up roll, not shown.

30

Rather than a single sided hook component, as shown in Fig. 8, a back-to-back hook and anchor fastening component can be coextruded as shown in Fig. 8, with the anchor material being in place of the substrate material. In such

60412-3486

5 a case, the base roller 804 includes anchor cavities around
its periphery. An apparatus for making such a structure is
shown in
published PCT application, PCT/US94/07556, filed on July 6,
1994 and published on January 19, 1995 which is
assigned to the assignee hereof.

10

An article that could have been made with the equipment
shown in Fig. 8 is shown schematically in Fig. 9. The hooks
916 are composed of a first material. A base 910 is unitary
with the hooks, having been extruded therewith. The
15 substrate 930 is composed of the same material, or a second,
different material. The joining region, which may take many
different physical forms, exhibits a transition from the
hook material to the substrate material.

The substrate may be a woven or a non woven fabric.

20 It has already been discussed to use a unitary
extrusion from which are molded hooks and a unitary base, as
well as a coextrusion, which joins a base with hooks to a
substrate. Other methods may be used for joining hooks to a
substrate. Another method is to laminate an already formed
25 substrate to a unitary hook and base, as the hook carrying
web is being extruded and formed. This technique is
described generally in U.S. Patent No. 5,260,015, issued
Nov. 9, 1993, entitled METHOD FOR MAKING A LAMINATED HOOK
FASTENER, in the name of William J. Kennedy et al.

30 This method may be
referred to as the "one-wrap" method. The apparatus for
implementing the method is shown schematically in Fig. 10.
As with the embodiment shown in Fig. 7, an extruder barrel
1001 melts and forces molten plastic 1003 through a die

1002, into the nip 1006 between a base roller 1004 and a
cavity roller 1005, that contains cavities 1011 to form the
hooks 1016 of a strip fastener 1000, which extend from a
web-like base 1010 composed of the same material as is the
5 hooks 1016. The strip fastener material formed at the nip
1006 travels around the periphery of the cavity roller 1005
and around the stripping roller 1013, which assists in
pulling the formed hook sheet from engagement with the
cavity roll 1005. The strip is then passed to a wind-up
10 roll, not shown.

A pre-formed sheet material 1030 is inserted into the
nip 1006 to create the strip fastener tape. The sheet
material bonds intimately with the unitary base 1010
composed of hook material to become an integral part of the
15 structure of the strip fastener. A set of pins 1017 may
help to carry the sheet material in a flat unwrinkled state.
Other rollers and tensioning equipment 1019 are used to
maintain the proper tension and flatness on the sheet
material that will form the laminated substrate.

20 At the nip 1006, the sheet material 1030 is laminated
to the hook material, as indicated by the small half-circles
downstream of the nip. (The half-circles are not indicative
of any circular structure. They are simply used to identify
what is typically a flat sheet-like structure.)

25 A fastener strip formed by the apparatus shown in Fig.
10 may also be represented schematically by Fig. 9. Again,
the hooks 916 and a unitary, base 910 are laminated to the
sheet material 930 forming a second substrate. A transition
region 950 is composed of both the sheet material and the
30 hook material.

There are many candidates for the sheet-like substrate
material. The material may be woven or non-woven. It may
constitute an open or a tight weave. It may be paper, with

or without an adhesive backing, or may constitute a thin sheet of foam. It can also constitute the loop component of a normal hook and loop fastener pair. Any one of the foregoing may be useful to enhance the anchoring of the hook component into the article being molded. The type of sheet material substrate to which the hooks are laminated is not material to the invention. Any of these substrate backing materials may be composed of a substantial portion that is magnetically attractive. As such, the laminated backing material would be attracted to the magnet in the mold, and would achieve the goals of the invention.

The invention does not depend on the method by which the hook elements or the substrate are manufactured. All that is required is that one or the other or both can be treated with a magnetic attractant, such that it can be attracted by the magnet in the mold.

Rather than the "one-wrap" laminating method shown in Fig. 10, an off-line method can be used after the hook and base material is formed alone, such as shown in Fig. 7. Afterward, two rolled webs, one of hook carrying base material, the other of the substrate, can be laminated together. At the same time, a third web of a thin protective film can be applied to cover the hooks, to protect them against intrusion of molding material. The film can be secured to the hook carrying base, and/or substrate, depending on their relative widths, ultrasonically, or by heat and pressure, or adhesive.

Most of the foregoing discussion has focused on the hooks being molded. However, this too is not required for the practice of the invention. For instance, U.S. Patent No. 2,717,437, issued in 1955 to George DeMestral, entitled VELVET TYPE FABRIC AND METHOD OF PRODUCING SAME discloses a hook component, which is entirely woven, from weft and warp threads and auxiliary warp threads. The auxiliary warp

threads are formed into loops, which are cut, to form hooks. Typically, the auxiliary warp threads are made from a monofilament plastic resin. This plastic resin can be composed of the magnetic attractant, as discussed above.

5 With such products, the hook material may also be referred to as "pile yarn" and the weft and warp threads, which compose the structure that serves as the base, are referred to as the ground yarns, or fabric.

While the foregoing has focused on a plastic matrix
10 material as one constituent for either the hooks or the substrate, with a magnetic attractant filler generally therethrough as another constituent, other mechanical forms of magnetically attractive articles are possible and within the contemplation of the invention. For instance, either
15 the hooks or the substrate can comprise a magnetically attractive core material, which is coated with or sheathed by a magnetically inert (non-attractive) material. Conversely, the articles can comprise a magnetically inert material, coated with a magnetically attractive material.
20 All that is required is that at least one of the fastening elements or the substrate comprise a magnetically inert material that is in some fashion intimately associated or treated with a magnetically attractive material.

The foregoing discussion has generally considered that
25 the fastening component to be incorporated into the mold be the hook carrying component. Although this is typical, it need not be the case. Therefore, the loop carrying component can alternatively be the portion of the fastener that is embedded in the molded article. In such case, as
30 shown in Fig. 11, the loop carrying component 1100 will be the component that will include the magnetically attractive material. All of the discussion above applies to this embodiment also. The loops 1116 may be made from a plastic

resin impregnated with a magnetically attractive powder, or any other suitable magnetically attractive form.

Thus, the invention accomplishes many goals. It provides a magnetically attractive fastening component, without a stiff, unwieldy, costly, heavy, possibly dangerous metal shim. Production times are kept low, because the magnetic attractant need not be added as a separate step after the hooks (or loops) are made, being provided at the time the hooks are made, in the normal way that the hooks are made. The fastening elements, such as the hooks, perform the dual functions of containing the magnetic attractant, and fastening to the mating element. Waste is minimized. No off-line steps are required to incorporate or remove the element containing the magnetic attractant. There are no problems of incompatible thermal properties engendered by the magnetically attractive material.

The foregoing discussion should be understood as illustrative and should not be considered to be limiting in any sense. While this invention has been particularly shown and described with references to preferred embodiments thereof, it will be understood by those skilled in the art that various changes in form and details may be made therein without departing from the spirit and scope of the invention as defined by the claims.

Having described the invention, what is claimed is:

60412-3486

CLAIMS:

1. A method of continuously forming a separable touch fastener strip having a flexible base unitarily molded with a plurality of fastening elements extending from a fastening surface thereof, the method comprising:
- 5 providing an apparatus having
- a cavity roller that contains cavities for forming the fastening elements, and
- a base roller which defines, together with the
- 10 cavity roller, a nip;
- supplying a first stream of molten plastic to the nip under conditions which cause the plastic of the first stream to fill the cavities of the cavity roller and form the fastening surface of the base; while
- 15 supplying a second stream of molten plastic to the nip along with the first stream of molten plastic, such that plastic of the first stream and plastic of the second stream are joined in the nip to form the fastener strip;
- allowing the formed fastener strip to travel
- 20 around the cavity roller; and then
- passing the formed fastener strip around a stripping roller to pull the formed fastener strip from engagement with the cavity roller.
2. The method of claim 1 wherein the fastener
- 25 elements are hook-shaped.
3. The method of any one of claims 1 and 2 wherein the first and second streams are of identical materials.

60412-3486

4. The method of any one of claims 1 and 2 wherein the first and second streams are of different materials.
5. The method of any one of claims 1, 2, 3 or 4 wherein the base further comprises a non-fastening surface.
- 5 6. The method of any one of claims 1, 2, 3, 4 or 5 wherein the first and second streams of plastic are forced through corresponding die orifices of a cross-head coextrusion die head.
7. The method of any one of claims 1, 2, 3, 4, 5 or 6
10 wherein a pool (P_h) of material of the first stream forms upstream ahead of the nip.
8. The method of claim 7 wherein a pool (P_s) of material of the second stream also forms upstream ahead of the nip.
- 15 9. The method of any one of claims 1, 2, 3, 4, 5, 6, 7 or 8 wherein material of the second stream is flattened and spread out into a web shape, along with a quantity of material of the first stream to form base.
10. The method of any one of claims 1, 2, 3, 4, 5, 6,
20 7, 8 or 9 further comprising, after passing the formed fastener strip around a stripping roller, passing the formed fastener strip to a wind-up roll.

SMART & BIGGAR

OTTAWA, CANADA

PATENT AGENTS

1/7

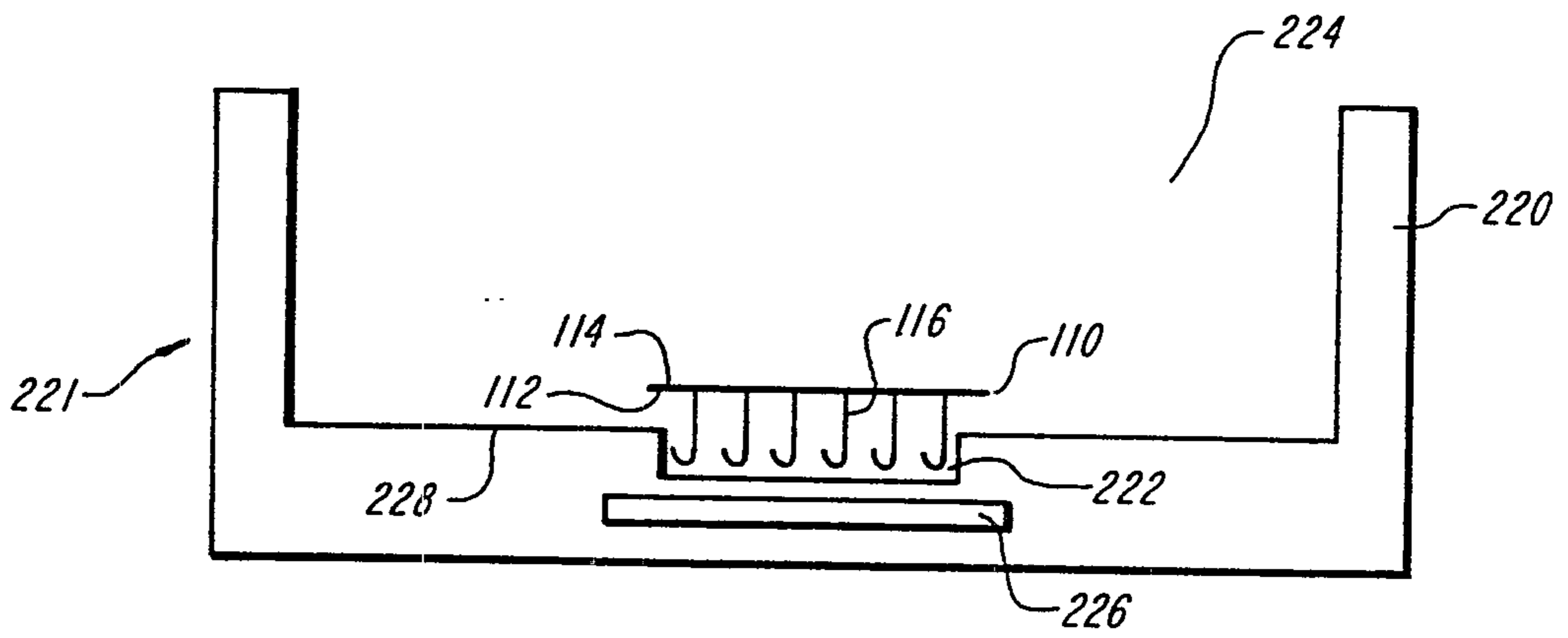
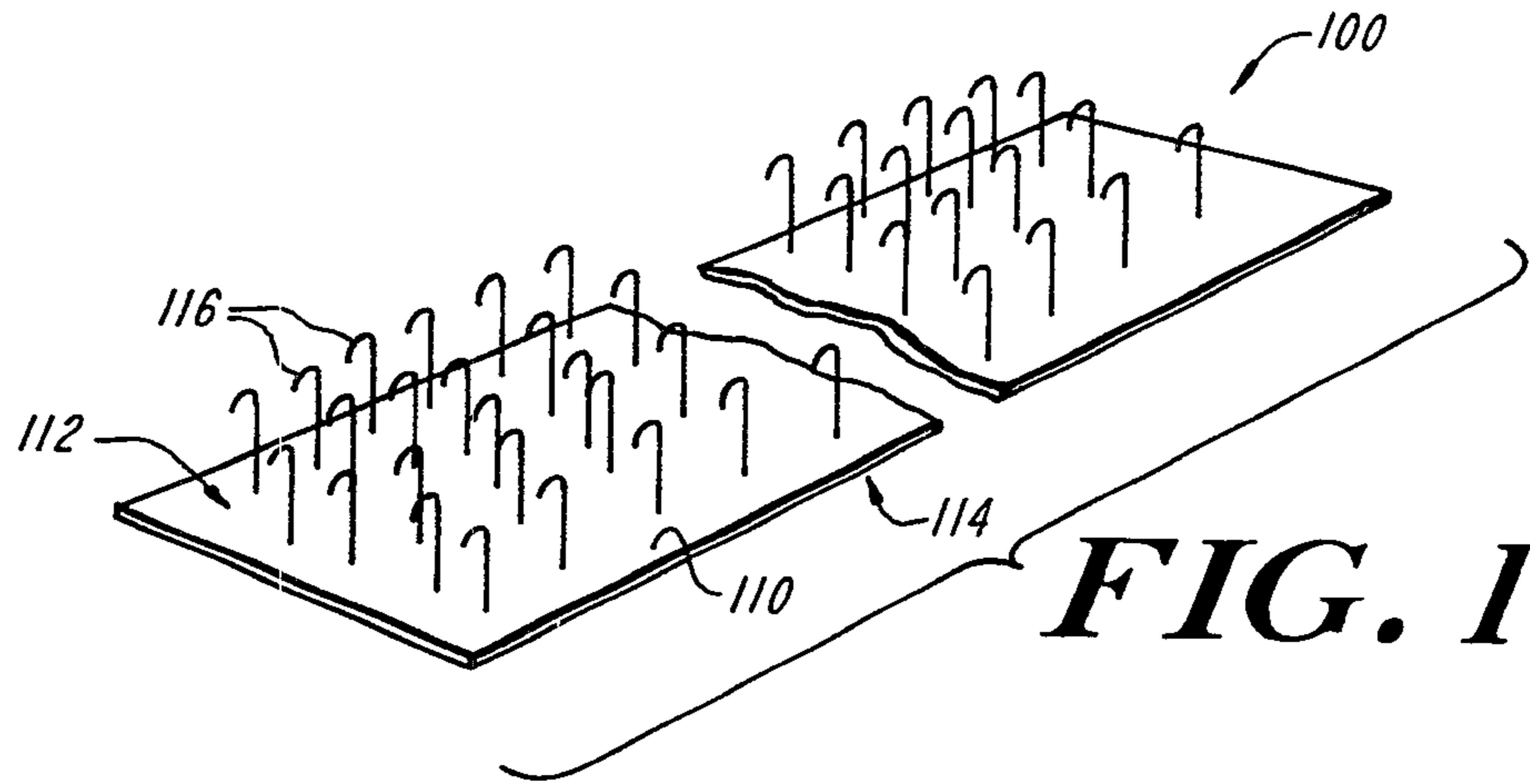

2/7

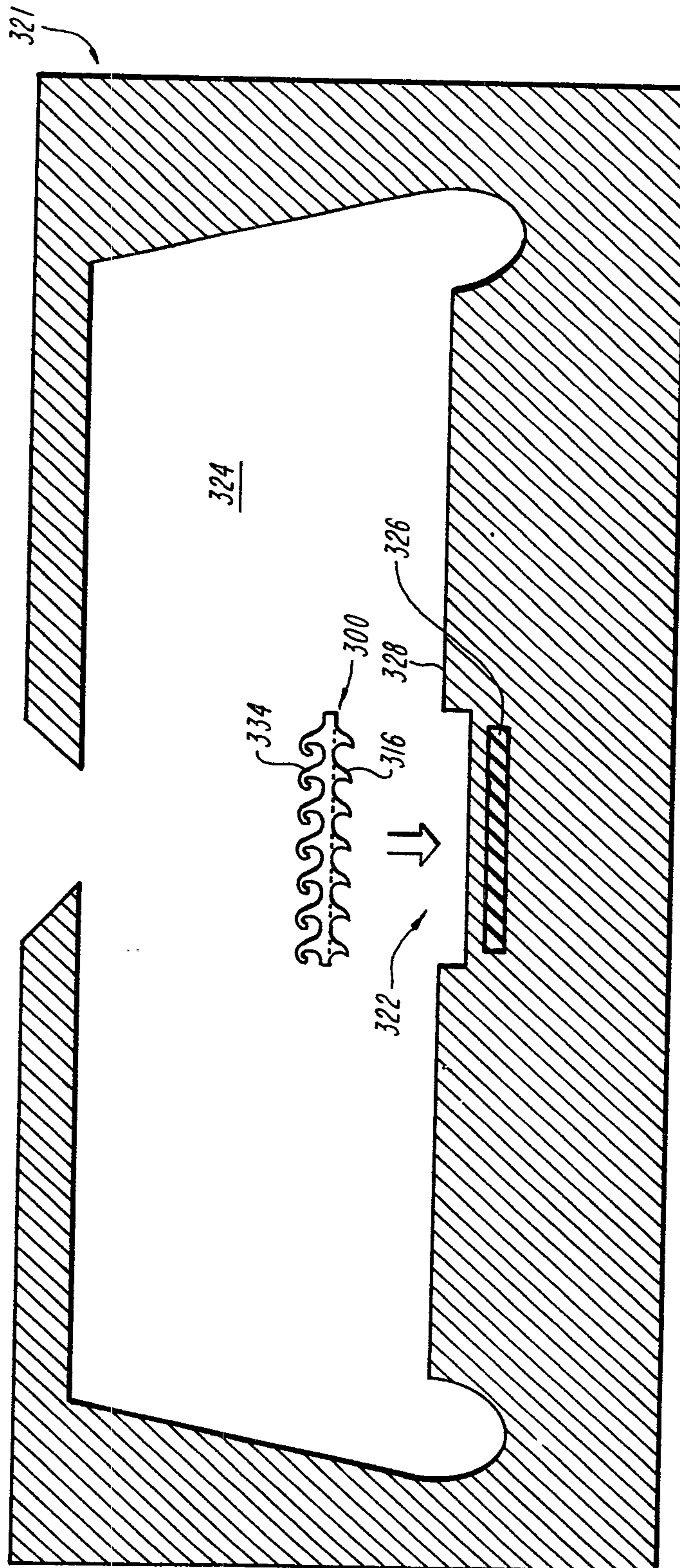

FIG. 3

3/7

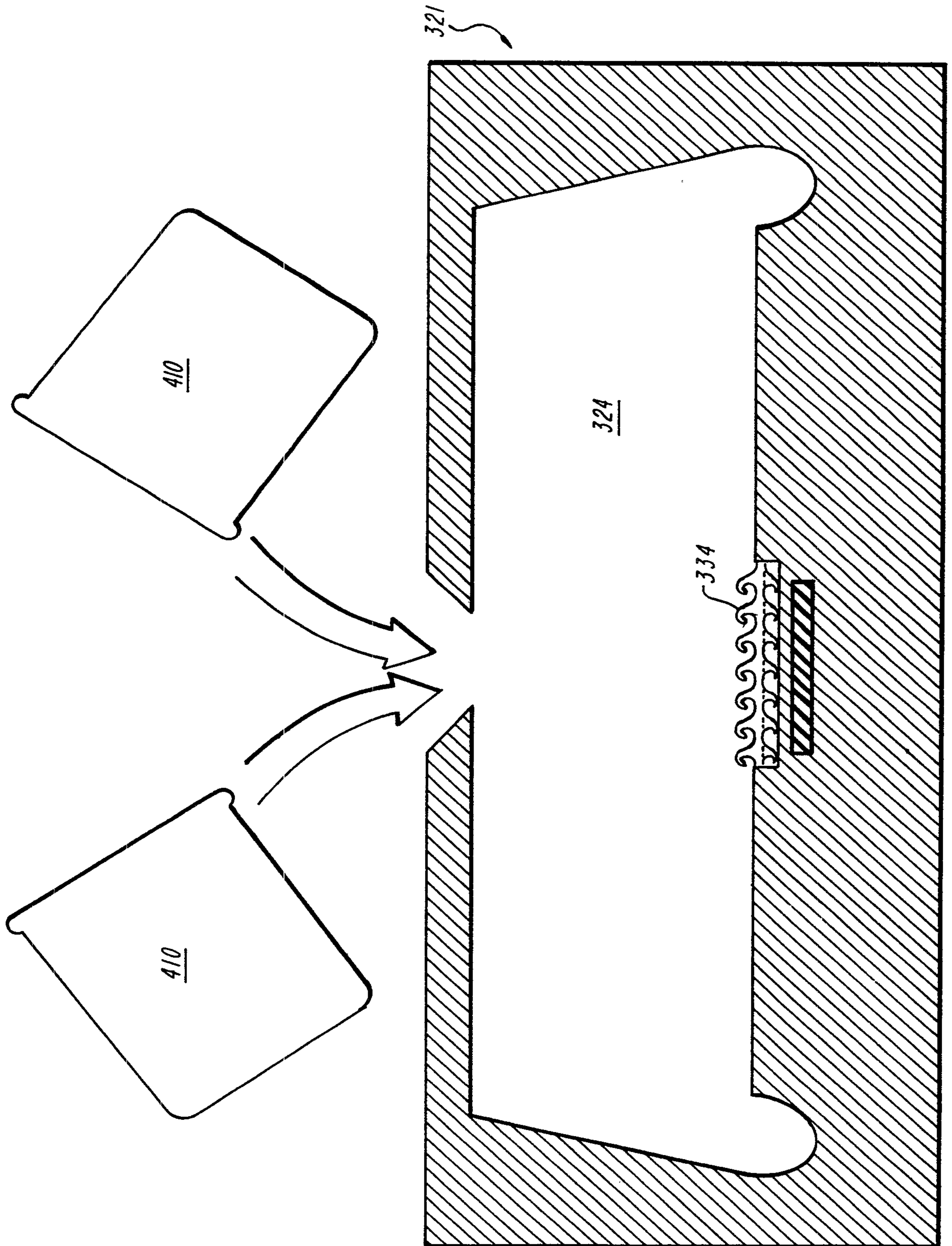

FIG. 4

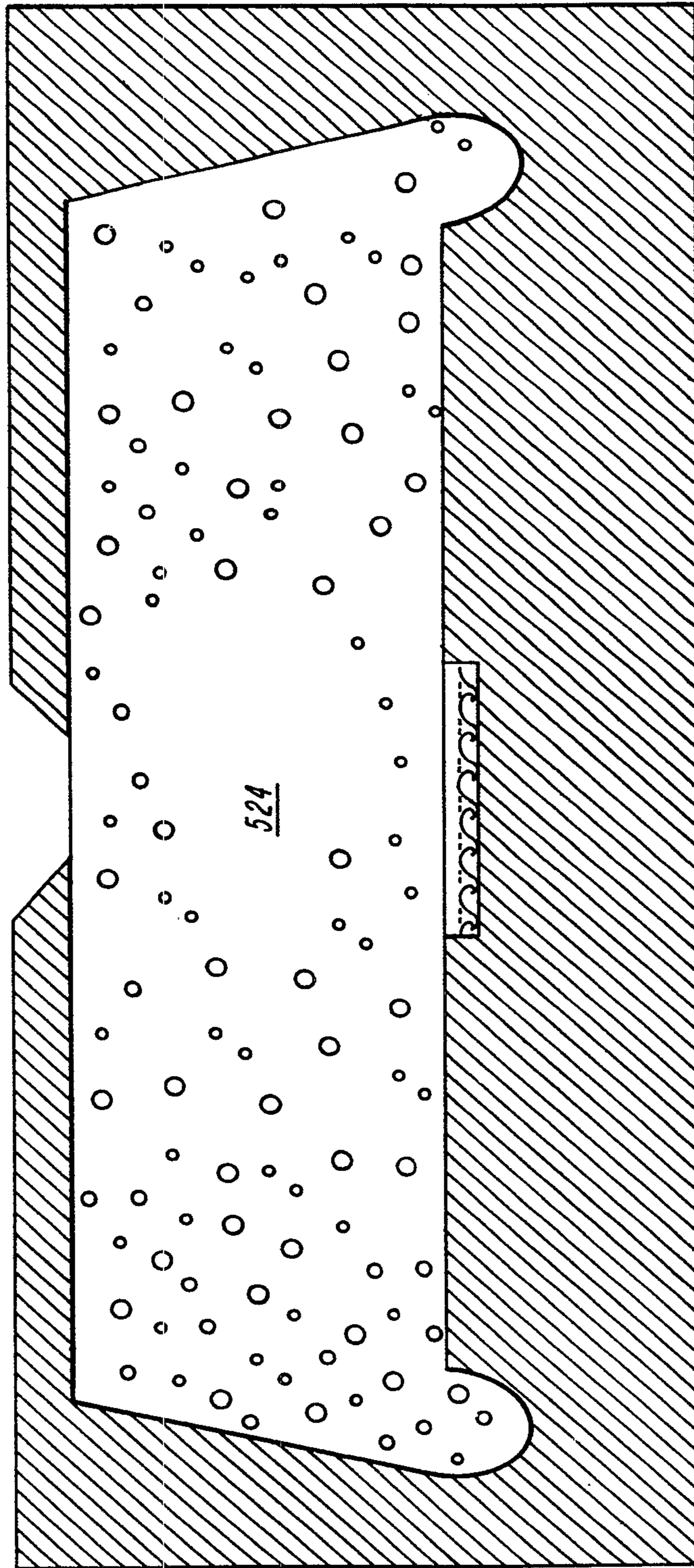

FIG. 5

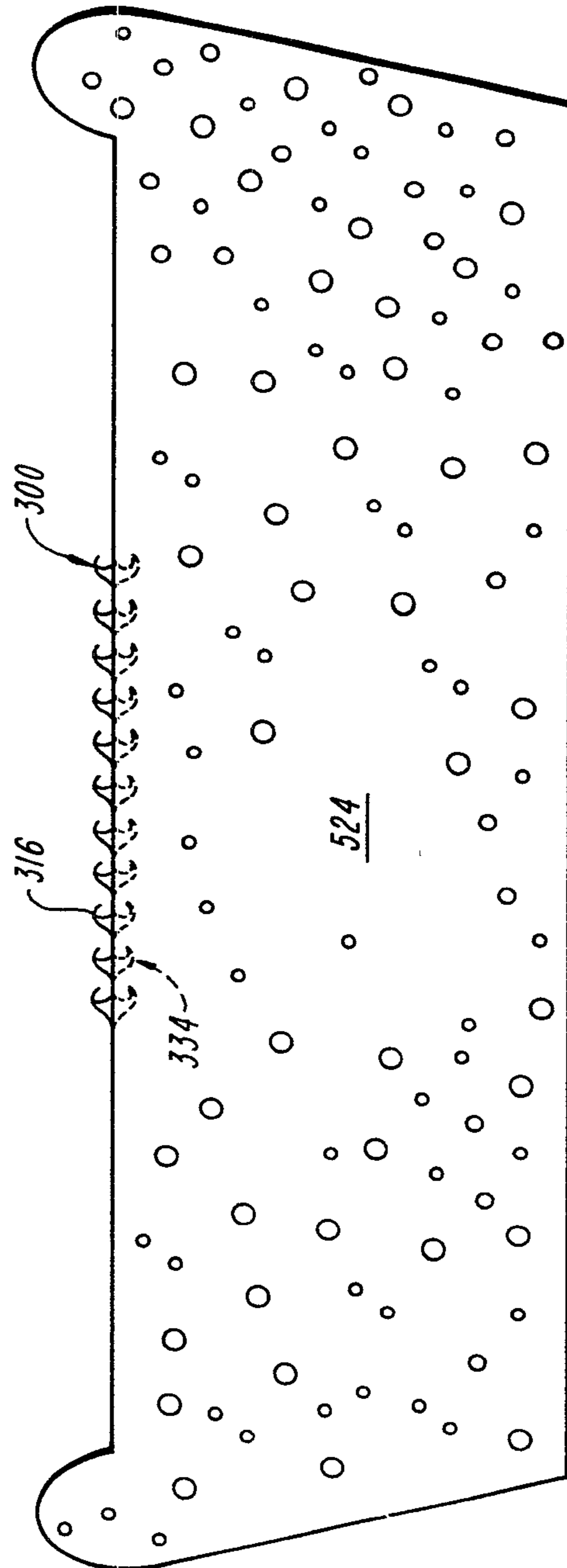

FIG. 6

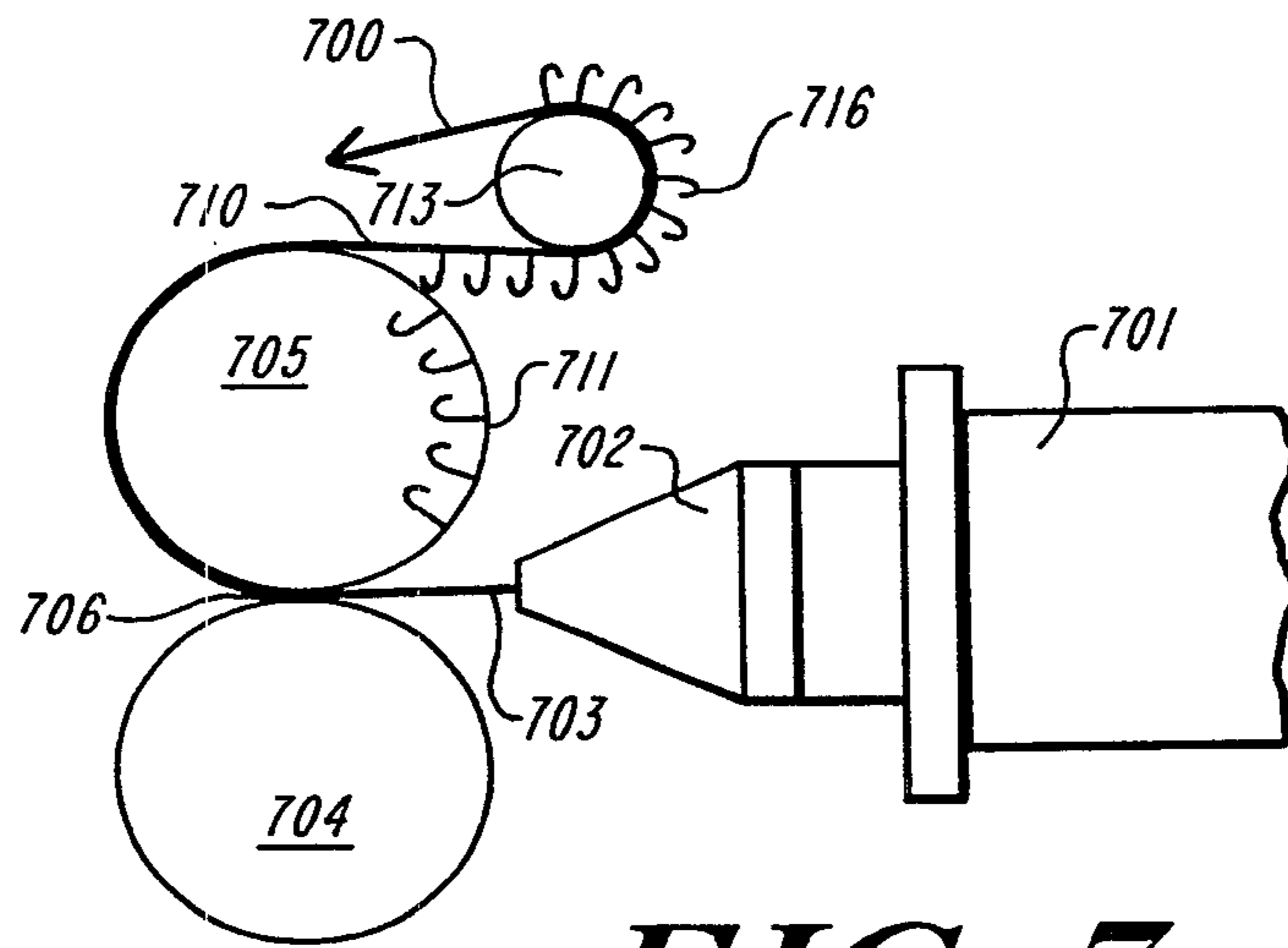

FIG. 7

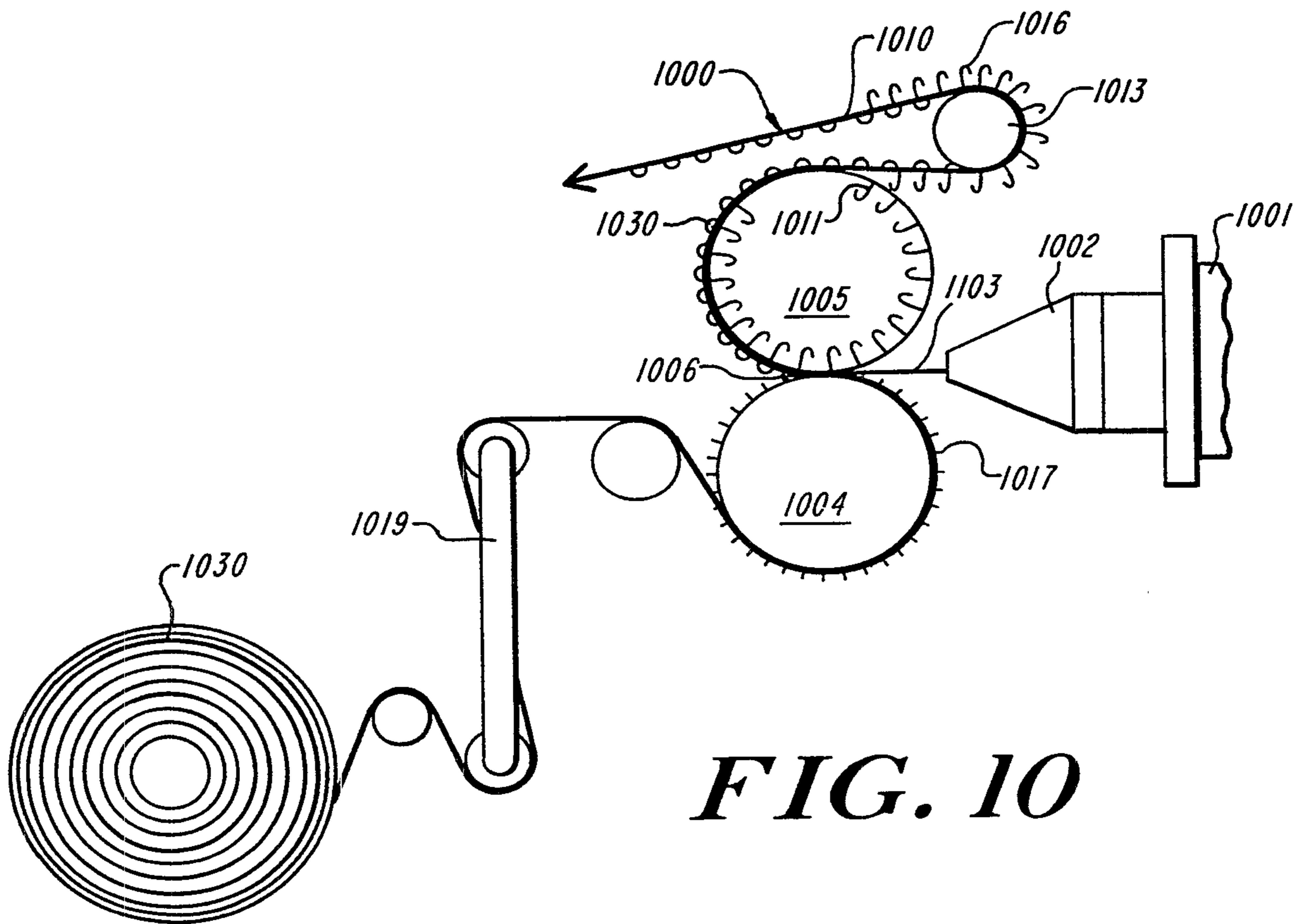

FIG. 10

7/7

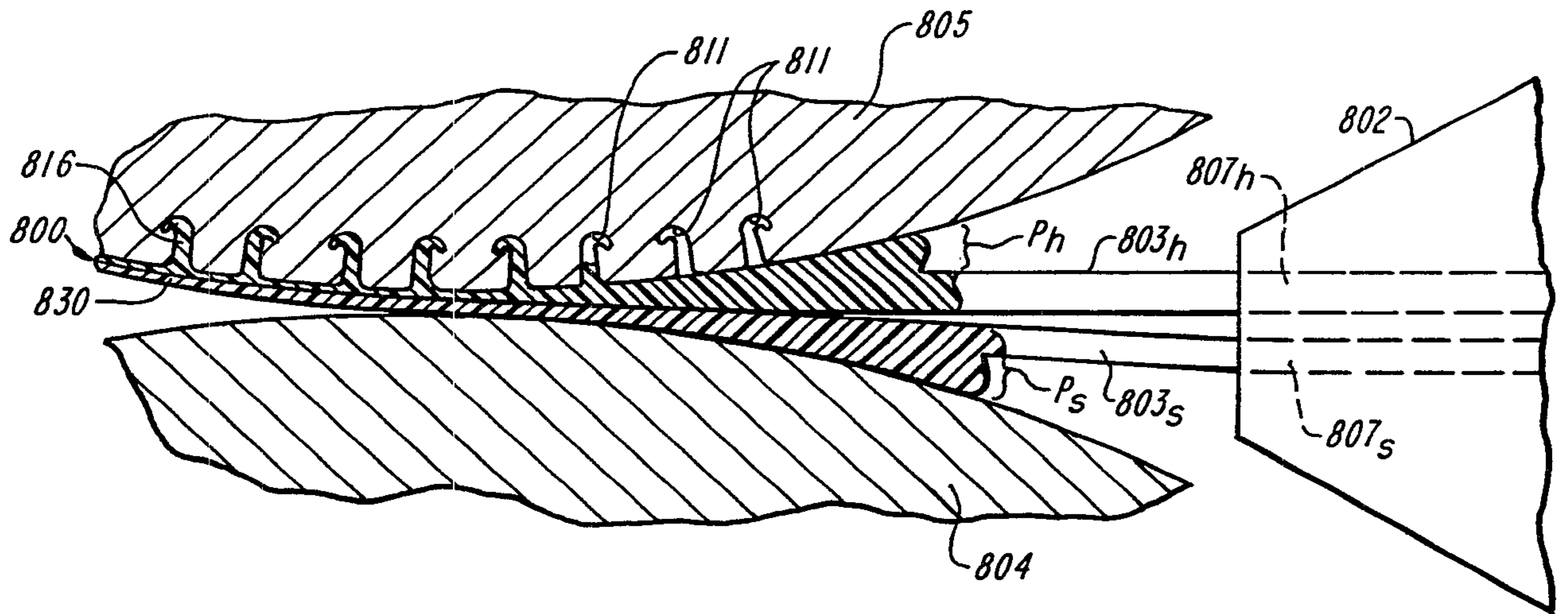

FIG. 8

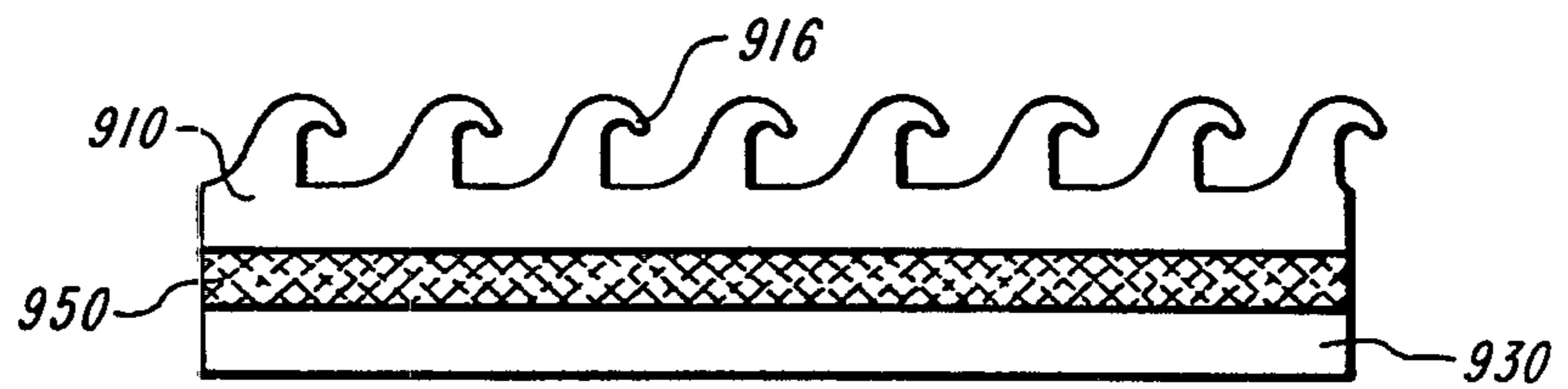

FIG. 9

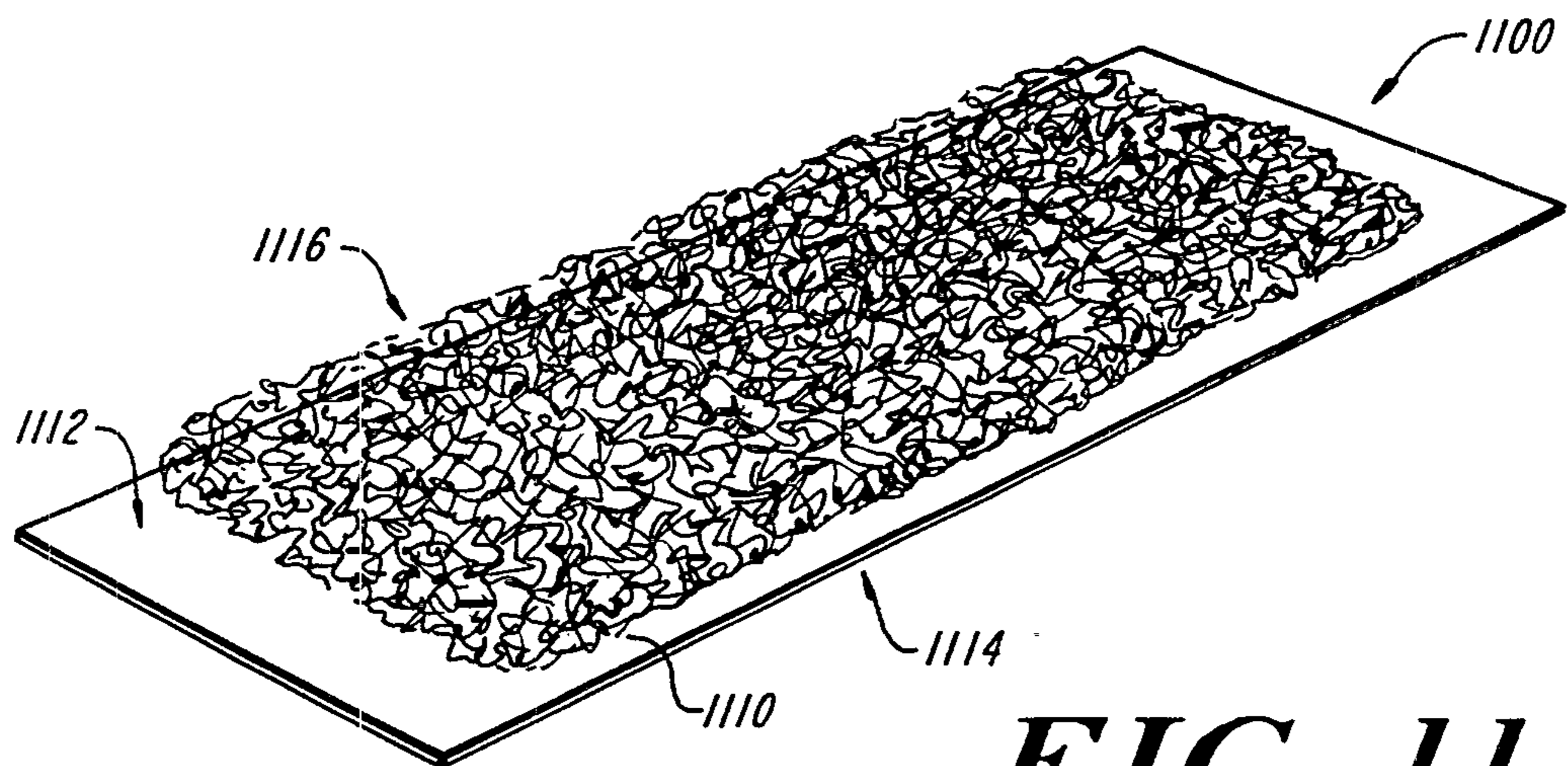

FIG. 11

