

(No Model.)

2 Sheets—Sheet .1

W. N. HARTSHORN.  
GRINDING MILL.

No. 526,313.

Patented Sept. 18, 1894.

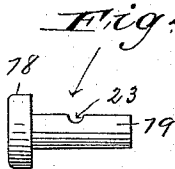
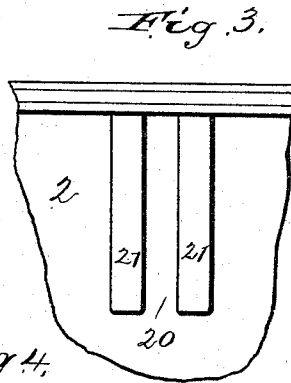
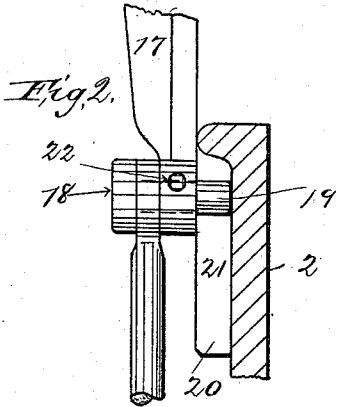
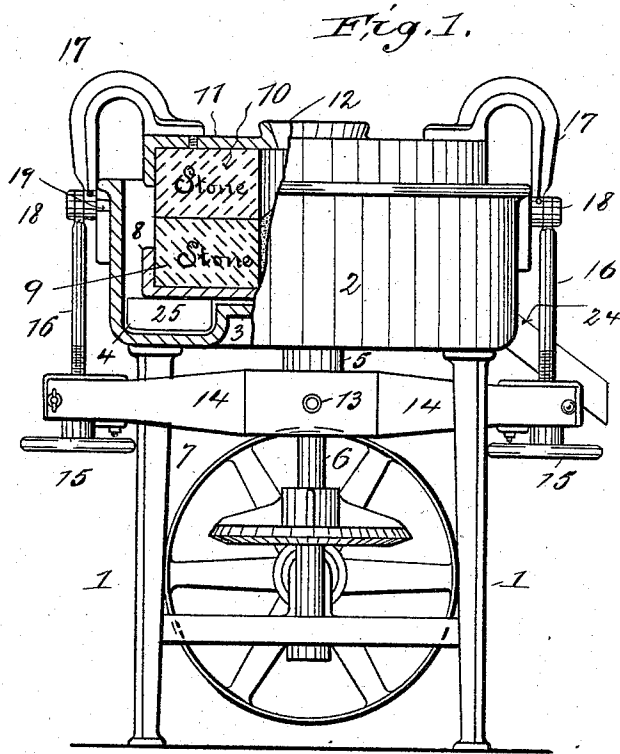

WITNESSES:  
*C. W. Benjamin*  
*M. E. Orant*

INVENTOR  
*Willie N. Hartshorn*  
BY *Clarence Ladd-Davis*  
ATTORNEY.

(No Model.)

2 Sheets—Sheet 2.

W. N. HARTSHORN.  
GRINDING MILL.

No. 526,313.

Patented Sept. 18, 1894.

Fig. 5.

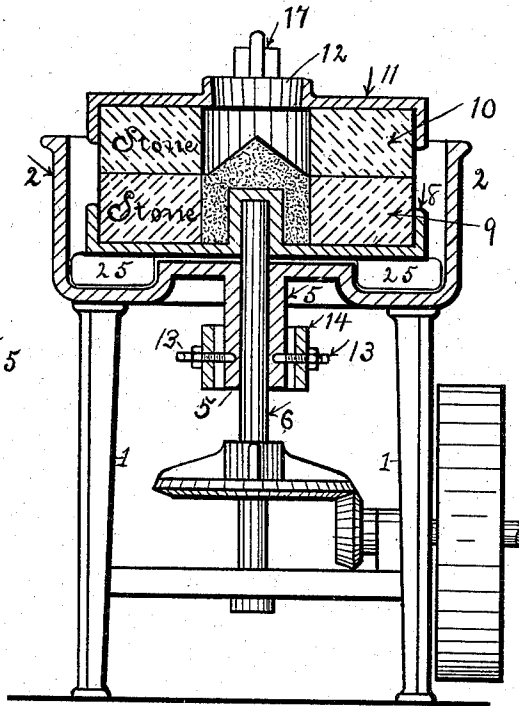

Fig. 7.

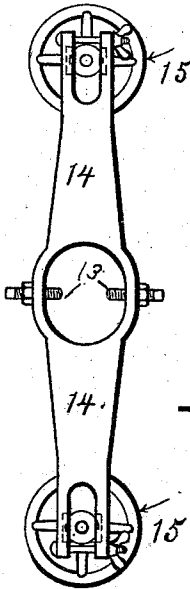
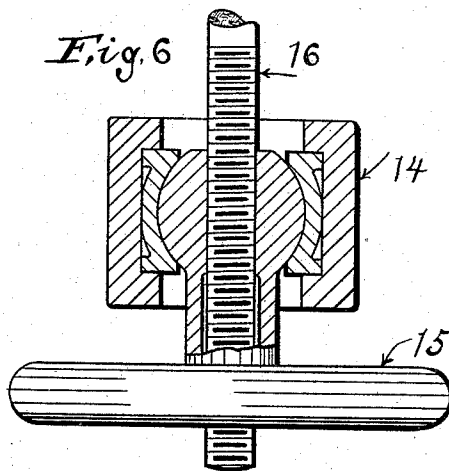

Fig. 6.



WITNESSES:

Frank Simon

H. J. Harris

INVENTOR

Willie N. Hartshorn,

BY

Clarence Ladd-Davis

ATTORNEY.

# UNITED STATES PATENT OFFICE.

WILLIS N. HARTSHORN, OF BROOKLYN, ASSIGNOR TO SAMUEL CAREY,  
OF NEW YORK, N. Y.

## GRINDING-MILL.

SPECIFICATION forming part of Letters Patent No. 526,313, dated September 18, 1894.

Application filed May 16, 1894. Serial No. 511,501. (No model.)

*To all whom it may concern:*

Be it known that I, WILLIS N. HARTSHORN, a citizen of the United States, residing at the city of Brooklyn, in the county of Kings and State of New York, have invented certain new and useful Improvements in Grinding-Mills, of which the following is a specification, such as will enable others skilled in the art to which it appertains to make and use the same.

My invention relates more especially to mills of the form commonly used for grinding cocoa and similar substances, and to that particular form thereof known as balanced stone mills, in which the grinding faces of the stones are held together in such manner as to grind accurately with the same pressure at all points of such surface, irrespective of the tendency of centrifugal force, when the center of gravity and the perpendicular geometrical center of the moving stone are not coincident, to throw such moving stone upon one side away from the still stone, and the object of my invention is to provide a mill of the class described, so made that while the sides of the grinding-pan are sufficiently high to catch all of the finished product of the mill as it is thrown by centrifugal force from between the grinding-stones after being ground by them, the grinding-faces of such stones will be kept in close contact with one another at all points, until such stones are worn so thin as to be no longer capable of use, and to that end my invention consists of the construction, combination and arrangement of the several parts of my improved grinding-mill, shown and described in the following specification of which the accompanying drawings form a part, wherein similar numerals of reference designate like or equivalent parts wherever found throughout the several views, and in which—

Figure 1, is a front view in elevation of my improved form of grinding-mill, a portion of the upper part thereof being shown in section in order to more fully show the construction thereof; and Figs. 2, 3 and 4, are views in detail on an enlarged scale, of portions of the construction shown in said Fig. 1. Fig. 5, is a side view, looking from the right of Fig. 1, of my improved form of mill, in central

vertical section thereof. Fig. 6, is an end view in central section of one end of the stone-balancing-lever and the ball-and-socket-joint connecting same with the stone, and Fig. 7, is a top plan view of such stone-balancing-lever and its supporting pivots and ball-and-socket-joints in the ends thereof.

Referring to the drawing, the reference numeral 1 designates the supporting base or frame-work of the mill, which may be of any desired form, preferably of that shown, and is like the rest of the mill with the exception of the grinding stones, formed preferably of iron or steel, and 2 designates the grinding-pan supported upon such base 1, which pan is preferably of substantially the shape shown, having a central raised portion or table 3 surrounded by an annular trough 4, and such central table 3 is provided with a central hole surrounded by a downwardly depending annular-flange 5, and up through such hole passes the main operating shaft 6 of the mill, to which shaft 6 motion is transmitted from any convenient source of power in any desired manner, preferably through a pulley 7 and suitable gear-wheels as shown.

Mounted upon the top of the main shaft 6, and rigidly secured thereto in any desired manner, is a back-plate 8 preferably of substantially the shape shown, to which is rigidly secured by means of a suitable cement, or in any other suitable manner, the bottom or moving grinding-stone of the mill, and resting upon this grinding-stone 9 is the still or top stone 10, which stone 10 is also rigidly secured in any suitable manner to a suitable back-plate 11, preferably of substantially the shape shown, both such back-plate 11 and the top stone 10 being provided with a central opening as shown at 12, through which the material to be ground is fed to the grinding surfaces of such stones in the well known usual manner.

Mounted upon and held in position on the downwardly depending flange 5 of the bottom portion of the grinding-pan 2 by a suitable pivot or pivots 13, in such manner as to oscillate freely thereon in a perpendicular plane is a lever 14 the ends of which project beyond the sides of the grinding-pan 2, as shown, and in suitable boxes formed in each

end of such lever, one upon each side, are revolvably secured the hubs of two hand-wheels 15, of suitable form, which are provided each with a suitable screwthreaded hole adapted to receive the threaded end of a suitable rod 16 as shown.

Rigidly secured to the top stone 10, preferably by being securely bolted to the back-plate 11 thereof, are two arms 17, preferably of the shape shown, which extend upward, and then curve outward and then downward, and end slightly below the top of the grinding-pan 2, as shown, and each of such arms is connected at its lower end by a pivotal connection with the upper end of the rod 16 which is located on that side of the mill, preferably formed by a headed bolt 18, which passes horizontally inward from the outside through suitable holes formed for that purpose through the lower end of such arms 17, and through the upper end of the rod 16, and such bolt 18 is in each case of such length that the inner end 19 thereof extends a short distance, say an inch or so, beyond the inner side of the lower end of the arm 17 into a perpendicular slot 20, located on the outside of the side-wall of the grinding-pan 2, and preferably consisting of the space lying between two perpendicular lugs 21 secured to or formed integral with the pan 2, and such bolt 18 is prevented from jarring out of place during the operation of the mill in any desired manner, preferably by a pin or screw 22 passing through a hole formed for that purpose in the arm 17 in such manner as to intersect a suitable groove 23, formed for that purpose in the bolt 18, as shown in Fig. 4.

Communicating with the bottom of the annular trough 4 of the grinding-pan 2, at any convenient point, is a discharge spout 24 of any suitable form. Rigidly secured to the bottom of the back-plate 8 of the moving lower stone 9, so as to be rotated therewith, and projecting down into the annular trough 4 are scrapers 25 by which the ground and finished product of the mill, after it falls from the stones into such trough 4 will be carried around to the discharge-spout 24 down which it will fall by gravity into any convenient receptacle provided for that purpose.

The operation of my improved form of grinding-mill is as follows:—The parts being in the position shown in Fig. 1, the hand-wheels 15 are turned so as to draw down the rods 16, and this will of course bring the grinding-surfaces of the upper and lower stones squarely against one another at all points, and if now motion is transmitted to the pulley 7, and the lower stone 9 is rotated thereby, even though such rate of rotation should be the highest possible, such stones cannot be separated at any point by centrifugal force, no matter how distant the center of gravity of the revolving stone may be from the geometrical center thereof, for the reason that as the points 13 and 18 together form as

it were gimbals by which such upper stone is supported, such upper stone 10 will in all cases move in unison with the lower stone, although kept from rotating therewith by the ends of the bolts 18 which rest in the slots 20, whereby in addition to grinding accurately at all points of the surfaces thereof, such stones will also wear away evenly, and as they so wear the rods 16 are from time to time tightened by a proper manipulation of the hand-wheel 15, and by reason of the upward curve of the arms 17, the top stone 10 may be eventually drawn down into the grinding pan until both stones are worn so thin as to be unfit for further use, before the upper portion of such arms 17 will by coming into contact with the top of the side-walls of the grinding-pan 2, prevent further descent of such top stone. It will be seen that even when new stones of the relative thickness shown in the drawings are used, that the top of the side-walls of the grinding-pan 2 will be sufficiently above the grinding surfaces of the stones to present an unbroken wall to catch the ground material or finished product of the mill, as it is by centrifugal force thrown from between them, and that at the same time the pivotal points 18 of the stone 10, when in that position are very closely in line with or somewhat below the center of gravity of such stone, and it will be seen that at all times such pivotal points 18 are below the top of such stone 10, and I have found by actual operation of these mills, that the operation thereof is much better when such pivots are located at or below the center of gravity thereof, than when located above the same.

It is evident that many changes in the construction, combination and arrangement of the several parts of my improved grinding-mill may be made without departing from the scope of my invention, and I do not intend to limit myself to any particular form of construction thereof, but,

Having now particularly described and ascertained the nature of my said invention and in what manner the same is to be performed, what I claim, and desire to secure by Letters Patent, is—

1. In a grinding-mill, the combination with a grinding-pan, of the grinding-stones located in the grinding-pan and having the grinding-surfaces below the top of the side wall of such grinding-pan, arms 17 secured to the still stone and extending outward and then downward outside of the grinding-pan to a point below the top of the side wall of such pan, rods 16 secured to the arms 17 by pivotal connections located outside of and below the top of the grinding-pan, a pivoted lever 14 to the ends of which are secured the lower ends of the rods 16, and means for preventing rotation of the still-stone, substantially as shown and described.

2. In a grinding-mill, the combination with a grinding-pan, of the grinding-stones located in the grinding-pan and having the grinding-

surfaces located below the top of the side wall of such grinding-pan, arms 17 secured to the still-stone and extending upward, outward and then downward outside of the grinding-pan, rods 16 secured to the arms 17 by pivotal connections located outside of and below the top of the grinding-pan, a pivoted lever 14 to the ends of which are secured the lower ends of the rods 16, and means for preventing rotation of the still-stone, substantially as shown and described.

3. In a grinding-mill, the combination with a grinding pan, of the grinding-stones located in the grinding-pan and having the grinding surfaces located below the top of the side wall of such grinding-pan, arms 17 secured to the still-stone and extending outward and then downward outside of the grinding-pan, rods 16 secured to the arms 17 by pivotal connections located outside of and below the top of the grinding-pan, a pivoted lever 14, ball sockets located one in each end of such lever 14, a ball located in each of such sockets and secured to the lower end of one of the rods 16, and means for preventing rotation of the still-stone, substantially as shown and described.

4. In a grinding-mill, the combination with a grinding-pan, of the grinding-stones located in the grinding-pan and having the grinding surfaces located below the top of the side wall of such grinding-pan, arms 17 secured to the still-stone and extending upward, outward and then downward outside of the grinding-pan, a pivoted lever 14, and rods 16 secured at the lower ends to the ends of the lever 14 and at their upper ends to the arms 17 by pivotal connections located outside of the

grinding-pan and adjacent to or below the center of gravity of the stone to which such arms 17 are attached, substantially as shown and described.

5. In a grinding-mill, the combination with a grinding pan, of the grinding-stones located in the grinding-pan and having the grinding surfaces located below the top of the side wall of such grinding-pan, arms 17 secured to the still stone and extending outward and then downward outside of the grinding-pan, a pivoted lever 14, and rods 16 secured at the lower ends to the ends of the lever 14 and at their upper ends to the arms 17 by pivotal connections located outside of the grinding-pan and adjacent to or below the center of gravity of the stone to which such arms 17 are attached, substantially as shown and described.

6. In a grinding-mill, the combination, with a grinding-pan having an unbroken side-wall, of the grinding-stones located in the grinding-pan and having the grinding surfaces below the top of the side wall of the grinding-pan, a pivoted lever 14, arms 17 secured to the still stone and extending outward and then downward outside of the grinding-pan, rods 16 pivotally connected with such arms and in connection with the ends of the lever 14, and slots 20 in which rest the ends of the bolts forming the pivots of the arms 17 and rods 16, substantially as shown and described.

Signed at the city and county of New York, in the State of New York, this 14th day of May, A. D. 1894.

WILLIS N. HARTSHORN.

Witnesses:

H. G. HARRIS,  
FRANK SIMON.