

(19)
(12)

(KR)
(B1)

(51) 。 Int. Cl. ⁷
F28F 3/00

(45)
(11)
(24)

2003 04 26
10 - 0381303
2003 04 09

(21) 10 - 2001 - 0002494
(22) 2001 01 16

(65) 2001 - 0035209
(43) 2001 05 07

(73) LG 101 301

(72) 134 - 36 15 5
14
17 312 502
995 - 15 B 401

:

(54)

				(12)	(14)
(10)					
(12)		(14)		(16)	(22)
	(12)		(14)		
가	,	(10)가		(10)가	가 (10)
(14)		(16)		(22)가	
,	(10)	(12)		가	(12) (14)
		(22)가			
(20)가					

2a

1a 1c

2a 2b

3a 3b

4

5a 5c 가

6a 6c

7

*

*

10 : 12 :

14 : 16 :

20 : 22 :

30 : 40 :

(Heat Sink)

가

가
10 50%

가

6a 6c (114) 7
(110) (130)
(112) (112) (110) 가
(110)

가

가 가 가 가 가
가 가 가 가

가 가 가 가
가 0.05 - 0.55 가 가
가 가 가 0.001 - 0.05 가

가

1a (10) 1c (20)
 , 2a 2b (10) (16) (22)
 , 3a 3b (10) (12) (1)

4) (22)
 (20) (40)

1a (14) 1c (10) (Foaming) (12)
 (Sintering)

2a (14) 2b (10)
 (12) 가 (Extrusion) 가 (Casting) (Air Space)
 가 (10) (14) (Sintered Alumina) (16)
 (22)가
 (20)

(14) (16) (22)가
 (12) (14) (22) 가 0.05 - 0.55
 (20)

3a 3b (10) (12)
 (14) 가 (12)
 (16) (22)가
 (20)

가 (10) (22) 가 (10)
 (10) (10) 가

(12) 가 (12) (14)
 (22)가 (12) (14) (22)
 가 0.001 - 0.05 (20)

(10) 가 (12) (14)
 (22) 가 (20) 4
 (16) (Die Casting) (10) 가 (40) (10)
 (20) 가 (10)

5a 5c (10) 가 (12)
 (14) (22)가

(20) (30) , () , (20) (20)
 가 (Space State) .

가 .

가 가 가 가 ,

(57)

1.

가 , (10) (14) (10)가 (16) (22)가

2.

1 , (10) (12) (14) 가 가
 (12) (14) (22) 가 0.05 - 0.55

3.

4.

1a

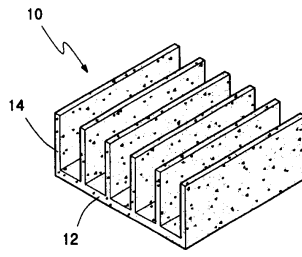

1b

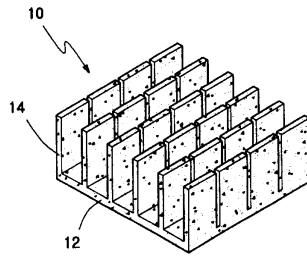

1c

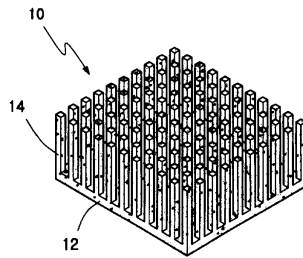

2a

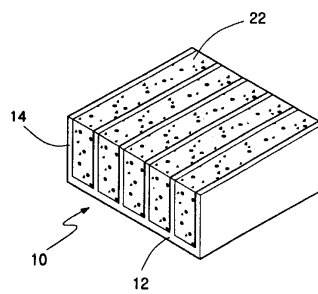

2b

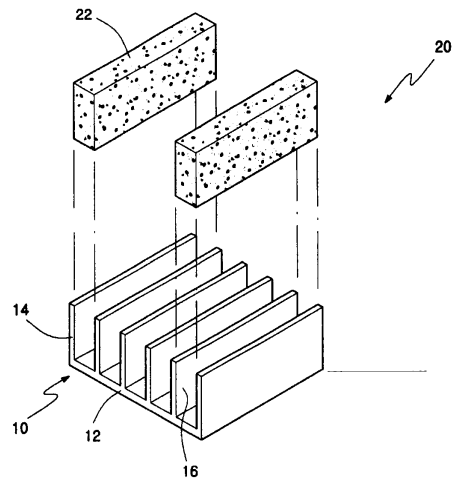

3a

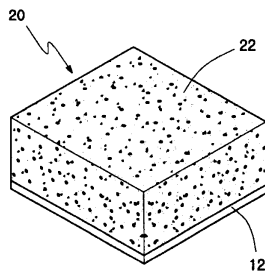

3b

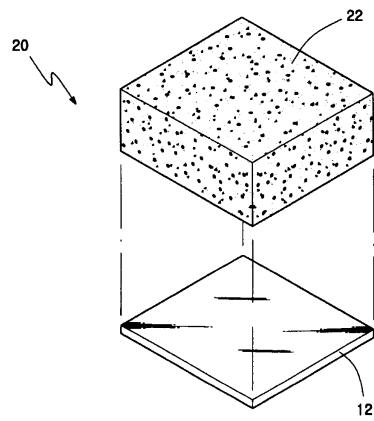

4

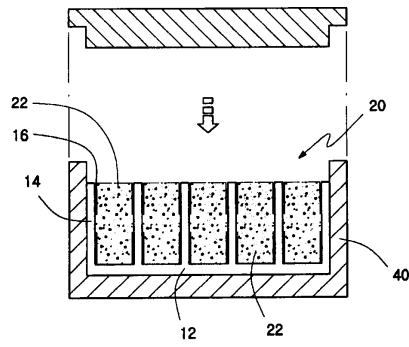

5a

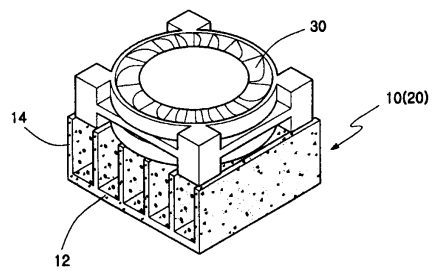

5b

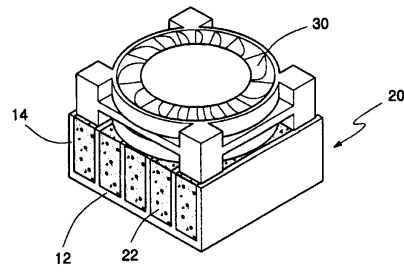

5c

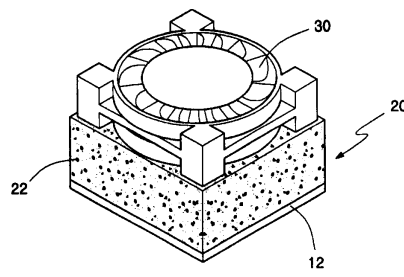

6a

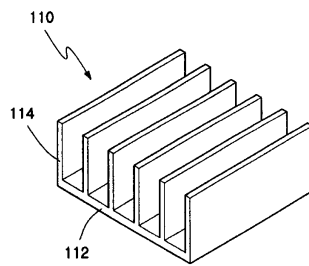

6b

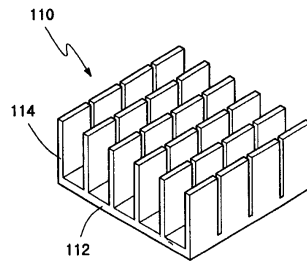

6c

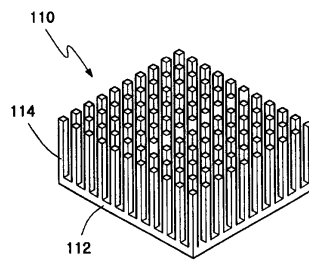

7

