



US010967943B2

(12) **United States Patent**  
**Kimura et al.**

(10) **Patent No.:** **US 10,967,943 B2**

(45) **Date of Patent:** **\*Apr. 6, 2021**

(54) **UNDERWATER MOBILE INSPECTION APPARATUS AND UNDERWATER INSPECTION EQUIPMENT**

(71) Applicant: **KAWASAKI JUKOGYO KABUSHIKI KAISHA, Kobe (JP)**

(72) Inventors: **Akira Kimura, Kobe (JP); Noriyuki Okaya, Kobe (JP); Kazuya Sumino, Osaka (JP); Minehiko Mukaida, Kobe (JP); Hiroaki Kagaya, Kobe (JP); Masanori Hamamatsu, Kobe (JP); Akiyoshi Saiki, Kobe (JP); Tetsuya Kubota, Kobe (JP); Masayuki Enomoto, Kobe (JP)**

(73) Assignee: **KAWASAKI JUKOGYO KABUSHIKI KAISHA, Kobe (JP)**

(\*) Notice: Subject to any disclaimer, the term of this patent is extended or adjusted under 35 U.S.C. 154(b) by 0 days.  
  
This patent is subject to a terminal disclaimer.

(21) Appl. No.: **16/572,766**

(22) Filed: **Sep. 17, 2019**

(65) **Prior Publication Data**

US 2020/0010161 A1 Jan. 9, 2020

**Related U.S. Application Data**

(63) Continuation of application No. 15/686,828, filed on Aug. 25, 2017, now Pat. No. 10,450,041, which is a (Continued)

(30) **Foreign Application Priority Data**

Sep. 26, 2011 (JP) ..... 2011-209325

(51) **Int. Cl.**

**B63G 8/00** (2006.01)

**B63C 11/48** (2006.01)

(Continued)

(52) **U.S. Cl.**

CPC ..... **B63G 8/001** (2013.01); **B63C 11/48** (2013.01); **B63C 11/52** (2013.01); **G05D 1/0692** (2013.01);

(Continued)

(58) **Field of Classification Search**

CPC ..... B63G 8/00; B63G 8/001; B63C 11/00; B63C 11/48; B63C 11/52; G05D 1/0692; B63B 59/00

(Continued)

(56) **References Cited**

**U.S. PATENT DOCUMENTS**

2,987,893 A 6/1961 Robinson, Jr.  
3,165,899 A 1/1965 Shatto, Jr.

(Continued)

**FOREIGN PATENT DOCUMENTS**

EP 0547685 A1 6/1993  
GB 2453645 A 4/2009

(Continued)

**OTHER PUBLICATIONS**

International Search Report issued in International Application No. PCT/JP2012/005821 dated Dec. 18, 2012.

(Continued)

*Primary Examiner* — Lars A Olson

(74) *Attorney, Agent, or Firm* — Oliff PLC

(57) **ABSTRACT**

An underwater mobile inspection apparatus capable of inspecting an inspection object on a seafloor while cruising includes a cruising body configured to submerge underwater and cruise along the inspection object so as to not come into contact with the inspection object, a first movable arm provided on the cruising-body, and an inspection tool unit provided on the first movable arm and including at least one of an image-capturing camera for use in visually inspecting the inspection object and a device configured to

(Continued)

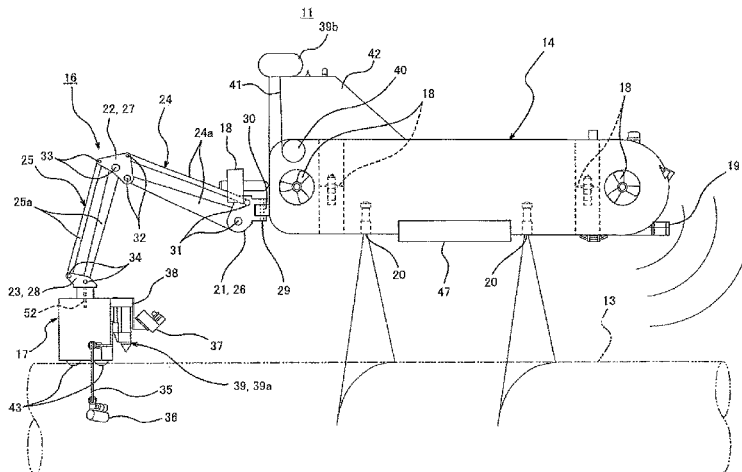

inspect a wall thickness of the inspection object by using an ultrasonic wave. A controller is configured to, when the cruising-body cruises along the inspection object so as to not come into contact with the inspection object, operate the first movable arm to move the inspection tool unit, such that a positional relationship of the inspection tool unit with the inspection object becomes a predetermined target positional relationship.

**11 Claims, 4 Drawing Sheets**

**Related U.S. Application Data**

continuation of application No. 15/340,344, filed on Nov. 1, 2016, now Pat. No. 9,776,695, which is a continuation of application No. 14/347,353, filed as application No. PCT/JP2012/005821 on Sep. 13, 2012, now Pat. No. 9,511,831.

- (51) **Int. Cl.**  
*B63C 11/52* (2006.01)  
*G05D 1/06* (2006.01)  
*B63B 59/00* (2006.01)
- (52) **U.S. Cl.**  
 CPC ..... *B63B 59/00* (2013.01); *B63G 2008/004* (2013.01); *B63G 2008/005* (2013.01); *B63G 2008/008* (2013.01)
- (58) **Field of Classification Search**  
 USPC ..... 114/313, 321, 322  
 See application file for complete search history.

(56)

**References Cited**

U.S. PATENT DOCUMENTS

3,381,485	A	5/1968	Crooks et al.
3,550,386	A	12/1970	Ballinger
3,621,911	A	11/1971	Baker et al.
3,987,741	A	10/1976	Tryon
4,502,407	A	3/1985	Stevens
4,620,819	A	11/1986	Marsland et al.
4,648,782	A	3/1987	Kraft
5,097,780	A	3/1992	Winchester
5,947,051	A	9/1999	Geiger
6,317,387	B1	11/2001	D'Amaddio et al.
6,928,947	B1	8/2005	Clapham
9,511,831	B2	12/2016	Kimura et al.
9,776,695	B2	10/2017	Kimura et al.
10,450,041	B2 *	10/2019	Kimura ..... B63C 11/48
2009/0031940	A1	2/2009	Stone et al.
2009/0114140	A1	5/2009	Guerrero et al.

FOREIGN PATENT DOCUMENTS

JP	60-138458	A	7/1985
JP	02-503182	A	10/1990
JP	2552547	Y2	10/1997
JP	9-329688	A	12/1997
JP	3044217	B1	5/2000
JP	2006-298288	A	11/2006
WO	89/07071	A2	8/1989

OTHER PUBLICATIONS

Jun. 23, 2015 Extended Search Report issued in European Application No. 12836311.6.

\* cited by examiner

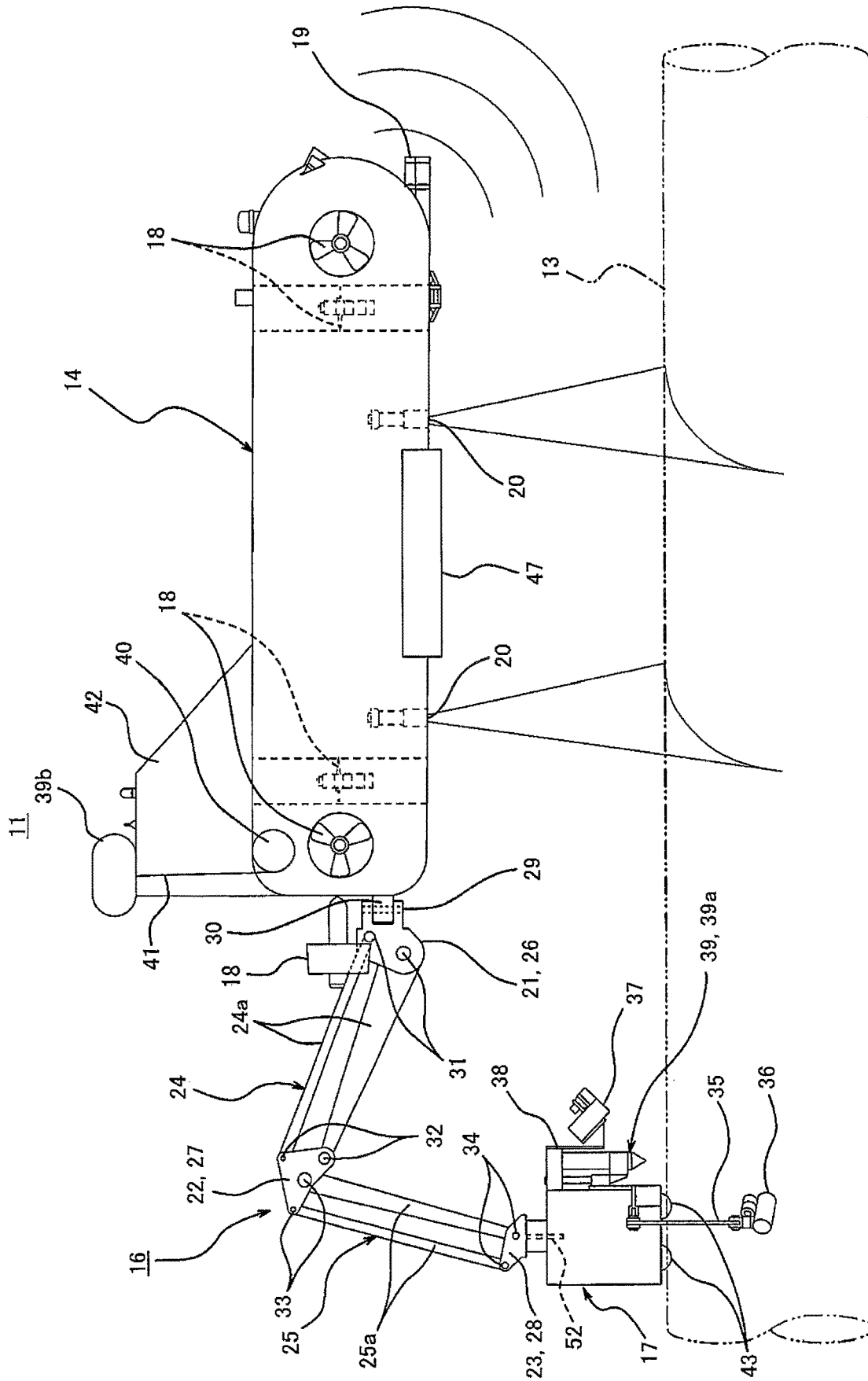

Fig. 1

11

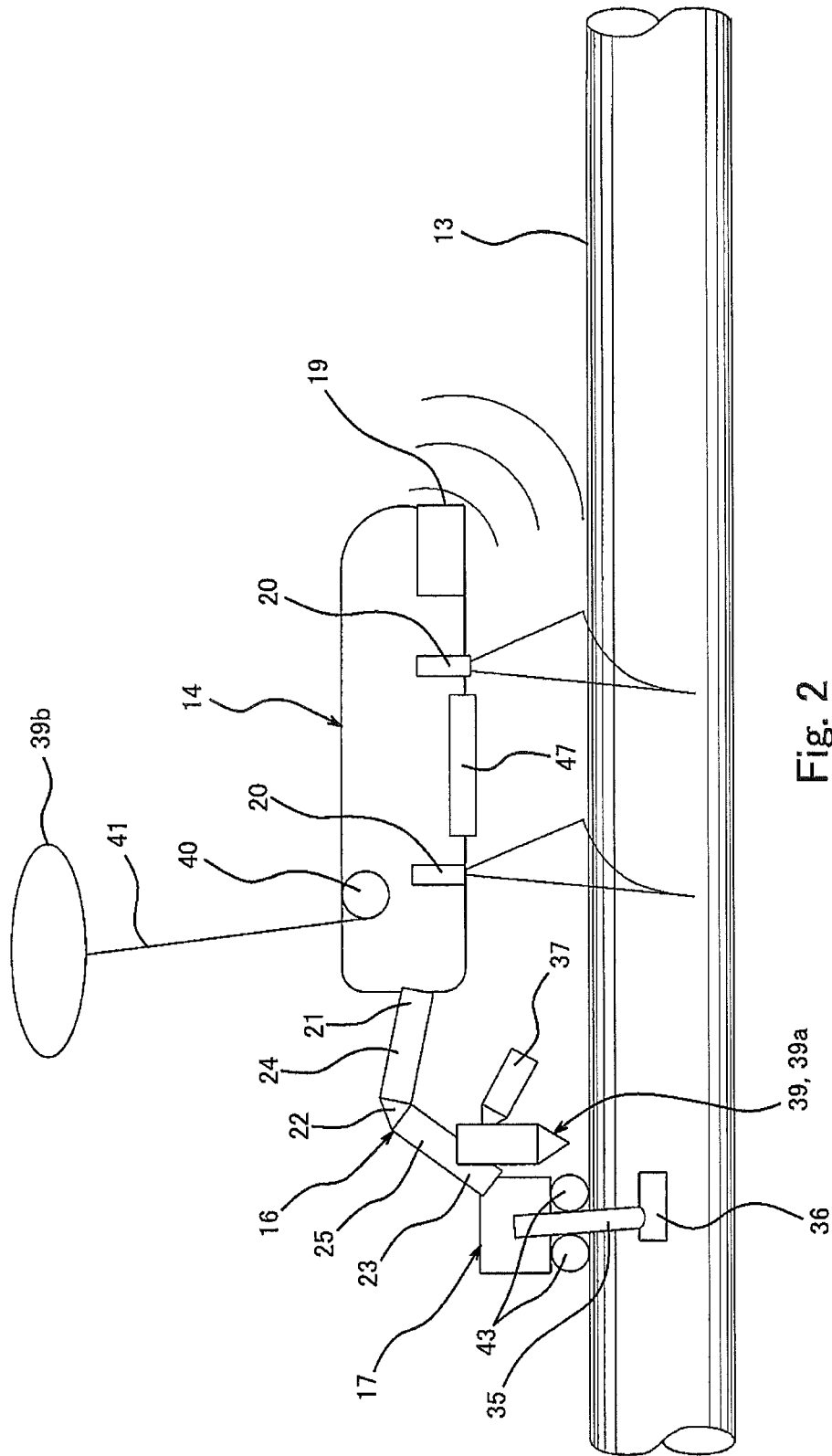

Fig. 2

Fig. 3A

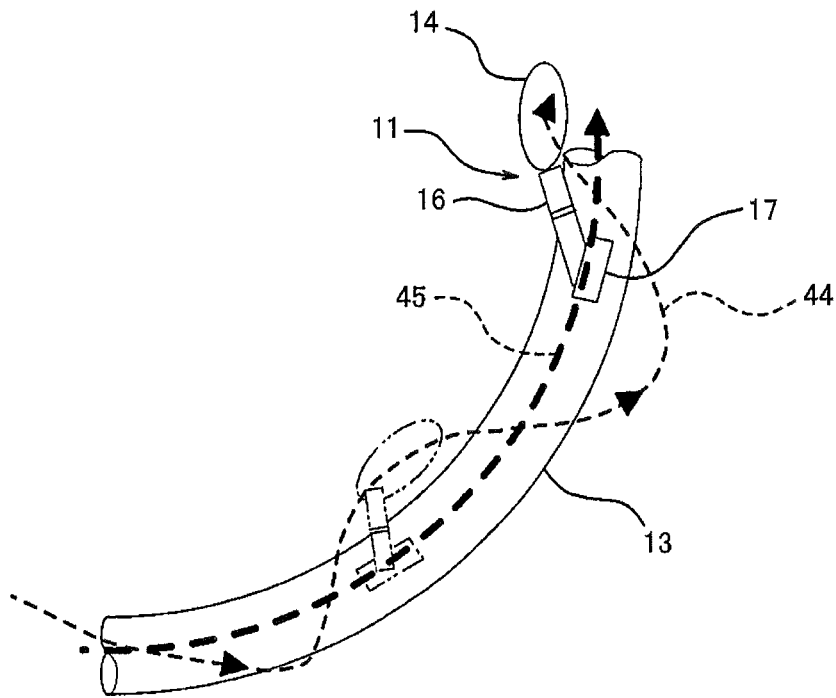
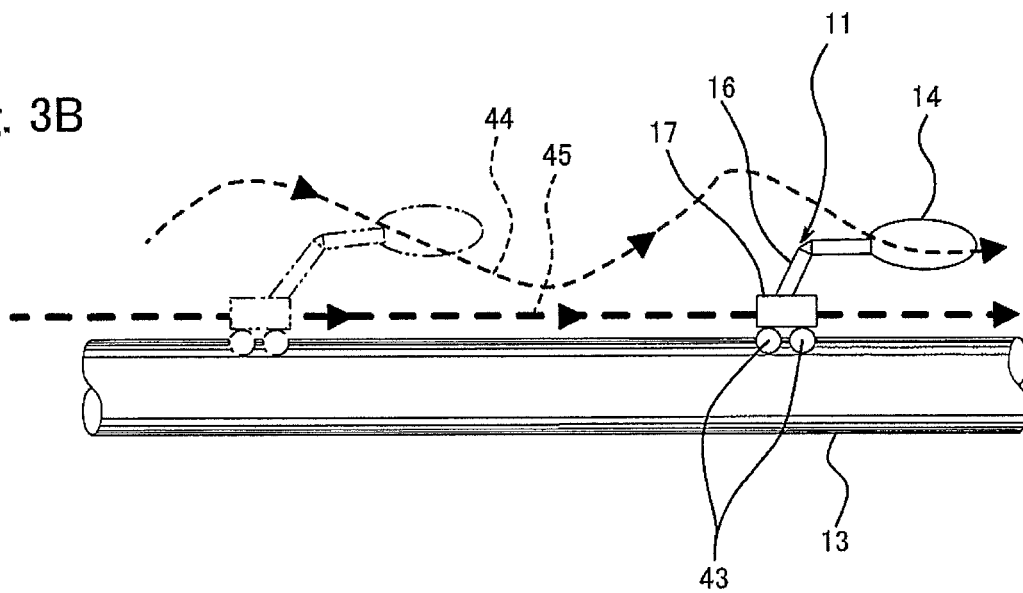

Fig. 3B



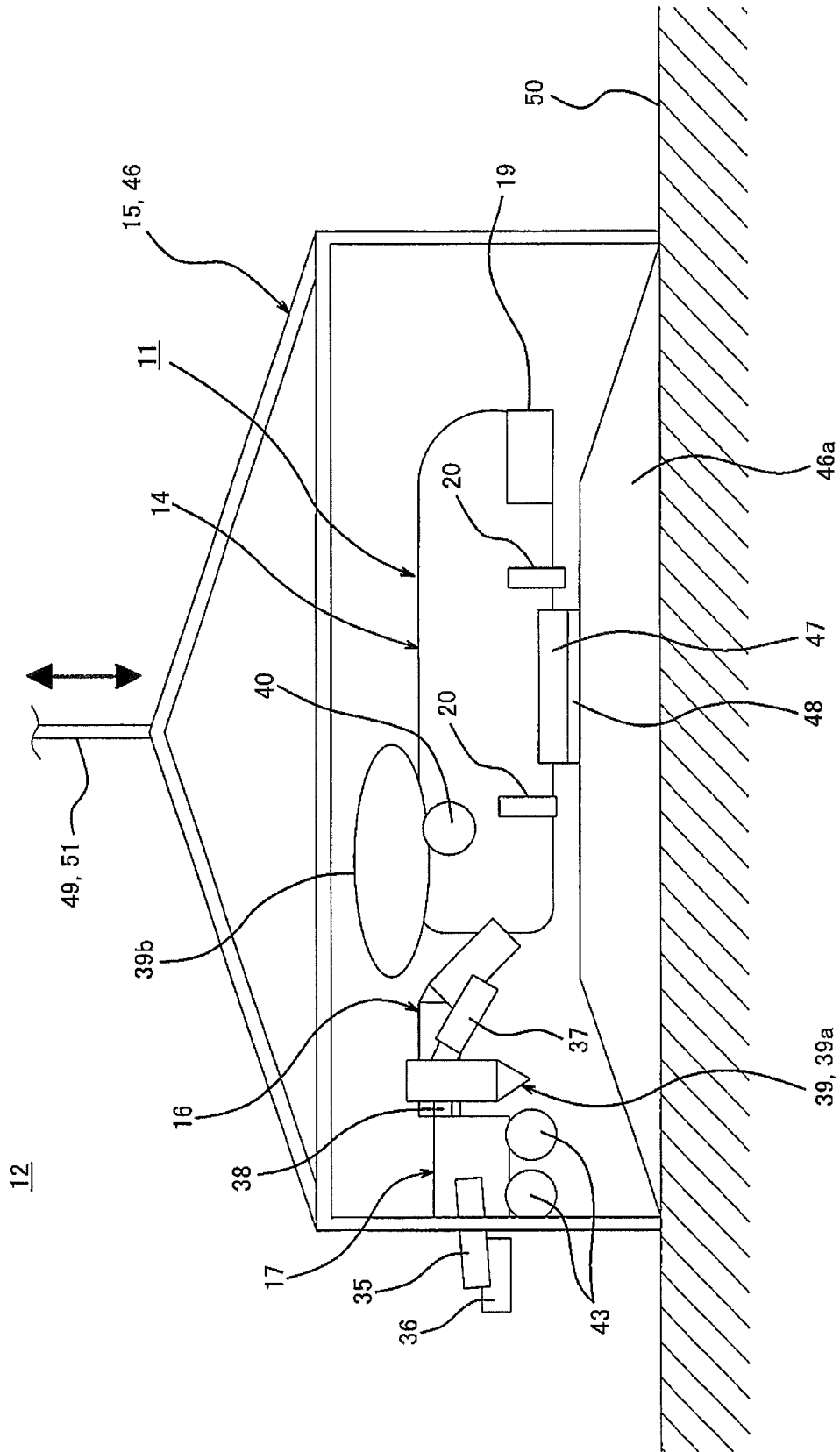

Fig. 4

**UNDERWATER MOBILE INSPECTION  
APPARATUS AND UNDERWATER  
INSPECTION EQUIPMENT**

CROSS REFERENCE TO RELATED  
APPLICATION

This application is a continuation of U.S. patent application Ser. No. 15/686,828, filed Aug. 25, 2017, which is a continuation of U.S. patent application Ser. No. 15/340,344, filed Nov. 1, 2016, which is a continuation of U.S. patent application Ser. No. 14/347,353, filed Apr. 25, 2014, now U.S. Pat. No. 9,511,831, which is a National Stage of PCT/JP2012/005821, filed Sep. 13, 2012, which claims priority to Japanese Patent Application No. 2011-209325, filed Sep. 26, 2011, the contents of which are incorporated herein by reference.

TECHNICAL FIELD

The present invention relates to, for example, underwater mobile inspection apparatuses capable of performing various work while cruising, including an inspection of an inspection object such as a subsea pipeline or a subsea structure, and to underwater inspection equipment.

BACKGROUND ART

One example of a conventional underwater mobile inspection apparatus is a remotely operated underwater vehicle (see Patent Literature 1, for example). The remotely operated underwater vehicle is configured to inspect and clean a subsea structure such as a tubular member installed on the seafloor while running on the subsea structure via casters. An operator can control the remotely operated underwater vehicle by operating a ground-based control device while viewing the subsea structure from the ground via a video camera provided on the remotely operated underwater vehicle.

The remotely operated underwater vehicle allows the operator to operate a large number of thrusters, manipulators, and the like provided on the vehicle from the ground, and therefore, the operator can control the vehicle to move under water in a flexible manner like the operator him or herself, thereby inspecting and cleaning the subsea structure.

CITATION LIST

Patent Literature

PTL 1: Japanese National Phase PCT Laid-Open Publication No. 2-503182

SUMMARY OF INVENTION

Technical Problem

However, the above-described conventional remotely operated underwater vehicle has problems as follows. Since the remotely operated underwater vehicle inspects and cleans a subsea structure such as a tubular member installed on the seafloor while running on the subsea structure via casters, force based on the mass of the vehicle is applied to the subsea structure, and there is a possibility that stress due to the force causes damage to the subsea structure.

Further, in the case of the conventional remotely operated underwater vehicle, since the force based on the mass of the

vehicle is applied to the subsea structure, loading of, for example, devices and manipulators necessary for the inspection and cleaning of the subsea structure onto the vehicle has a certain limit in consideration of increase in the loaded mass onto the vehicle. Such limitation is an obstacle to improvement in the quality of various work, including the inspection and cleaning of the subsea structure.

The present invention has been made to solve the above-described problems. An object of the present invention is to provide an underwater mobile inspection apparatus and underwater inspection equipment, which make it possible to prevent damage to an inspection object such as a subsea structure, the damage being due to receiving force based on the mass of a cruising body, and improve the quality of various work, including an inspection of the inspection object.

Solution to Problem

An underwater mobile inspection apparatus according to the present invention is capable of inspecting an inspection object on a seafloor while cruising. The underwater mobile inspection apparatus includes: a cruising body configured to submerge under water and cruise along the inspection object in such a manner as not to come into contact with the inspection object; a first movable arm provided on the cruising body; an inspection tool unit for use in inspecting the inspection object, the inspection tool unit being provided on the first movable arm; and a controller configured to, when the cruising body cruises along the inspection object in such a manner as not to come into contact with the inspection object, operate the first movable arm to move the inspection tool unit, such that a positional relationship of the inspection tool unit with the inspection object becomes a predetermined target positional relationship.

According to the underwater mobile inspection apparatus of the present invention, the cruising body can submerge under water and cruise along the inspection object in such a manner as not to come into contact with the inspection object. At the time, the inspection tool unit provided on the cruising body via the first movable arm can be controlled to follow the cruising body. When the cruising body cruises along the inspection object in such a manner as not to come into contact with the inspection object, the controller can operate the first movable arm to move the inspection tool unit, such that the positional relationship of the inspection tool unit with the inspection object becomes a predetermined target positional relationship. This makes it possible to precisely inspect an inspection target area of the inspection object by using the inspection tool unit.

In the underwater mobile inspection apparatus according to the present invention, the cruising body may include an inspection object detector configured to obtain inspection object information containing a positional relationship between the cruising body and the inspection object and a shape of the inspection object, and the controller may control the cruising body based on the inspection object information, such that the cruising body autonomously cruises along the inspection object in such a manner as not to come into contact with the inspection object.

The above configuration allows the controller to control the cruising body based on the inspection object information, such that the cruising body autonomously cruises along the inspection object in such a manner as not to come into contact with the inspection object. The inspection object information is information containing, for example, a positional relationship between the cruising body and a pipeline

and the shape of the pipeline. Since the cruising body is configured to autonomously cruise along the inspection object, it is not necessary to remote-control the underwater mobile inspection apparatus from an offshore support ship, and the inspection object can be inspected automatically. This makes it possible to reduce labor hours, labor costs, and costs of the support ship for inspecting the inspection object.

The underwater mobile inspection apparatus according to the present invention may include: an inspection object detector included in the cruising body and configured to obtain inspection object information containing a positional relationship between the inspection tool unit and the inspection object and a shape of the inspection object; a second movable arm provided on the inspection tool unit; and an image-capturing camera for use in visually inspecting the inspection object, the image-capturing camera being provided on the second movable arm. The controller may control the second movable arm based on the inspection object information, such that a positional relationship of the image-capturing camera with the inspection object becomes a predetermined target positional relationship.

According to the above configuration, when the cruising body cruises along the inspection object in such a manner as not to come into contact with the inspection object, the controller can operate the second movable arm based on the inspection object information obtained by the inspection object detector to move the image-capturing camera, such that the positional relationship of the image-capturing camera with the inspection object becomes a predetermined target positional relationship. This allows the image-capturing camera to precisely capture an image of the external view of a predetermined target area of the inspection object. By visually confirming image data of the captured image, an operator is allowed to perform precise visual inspection of a subsea pipeline.

In the underwater mobile inspection apparatus according to the present invention, the inspection tool unit may include at least one of an anti-corrosion inspection device and a wall thickness inspection device.

According to the above configuration, when the underwater mobile inspection apparatus submerges under water and cruises along the inspection object in such a manner as not to collie into contact with the inspection object, for example, the degree of degradation of anti-corrosion treatment of the inspection object can be inspected by using the anti-corrosion inspection device. In addition, the wall thickness of the inspection object can be inspected by using the wall thickness inspection device. Thus, the degree of corrosion of the inspection object and the presence or absence of damage to the inspection object can be inspected.

In the underwater mobile inspection apparatus according to the present invention, the anti-corrosion inspection device may include an anti-corrosion potential measurement device. The anti-corrosion potential measurement device may include: a potential measurement probe provided on the inspection tool unit; and a remote electrode connected to a linear object reeled out from an electrode winch provided on the cruising body.

When the anti-corrosion potential measurement device is used as the anti-corrosion inspection device, first, the linear object is reeled out from the electrode winch of the cruising body by a predetermined length, and the remote electrode connected to the linear object is moved away from the potential measurement probe of the inspection tool unit. Next, a potential difference between the potential measurement probe positioned near the inspection object and the remote electrode is measured. Based on the measured poten-

tial difference, the degree of anti-corrosion protection (i.e., the degree of corrosion) of the inspection object can be inspected. The electrode winch for reeling in or out the linear object to which the remote electrode of the anti-corrosion potential measurement device is connected is provided on the cruising body. Since the cruising body can cruise along the inspection object in such a manner as not to come into contact with the inspection object, damage to the inspection object due to force based on the mass of the cruising body including the electrode winch can be prevented.

In the underwater mobile inspection apparatus according to the present invention, the first movable arm may include a parallel link mechanism.

The above configuration makes it possible to reduce a necessary number of joints of the first movable arm for the controller to operate the first movable arm to move the inspection tool unit such that the positional relationship of the inspection tool unit with the inspection object becomes a predetermined target positional relationship. As a result, a compact and light-weight first movable arm can be provided, and also, the control of the first movable arm can be readily performed.

In the underwater mobile inspection apparatus according to the present invention, the inspection tool unit may be provided with a running part configured to allow the inspection tool unit to run on the inspection object, and the controller may operate the first movable arm by force feedback control, such that the inspection tool unit is in pressure contact with the inspection object with predetermined target pressing force.

According to the above configuration, the inspection tool unit can run on the inspection object while following the cruising of the cruising body. Since the inspection tool unit runs on the inspection object, the inspection object serves to assist in guiding the inspection tool unit to be in a predetermined target positional relationship with the inspection object. The controller is configured to operate the first movable arm by force feedback control, such that the inspection tool unit is in pressure contact with the inspection object with predetermined target pressing force. Therefore, even though there is the weight of the inspection tool unit as well as inertial force exerted on the inspection tool unit, force applied to the inspection object can be controlled to be substantially the target pressing force. This consequently makes it possible to prevent a situation where the inspection object receives the weight of the cruising body and inertial force exerted on the cruising body and thereby becomes damaged.

In the underwater mobile inspection apparatus according to the present invention, the running part may be a wheel.

By thus using the wheel as the running part, the body of the inspection tool unit can be prevented from coming into contact with the inspection object, and thereby damage to the inspection tool unit due to such contact can be prevented.

Underwater inspection equipment according to the present invention includes: the underwater mobile inspection apparatus according to the present invention; and a docking station disposed on a seafloor. The underwater mobile inspection apparatus is configured to be docked with and undocked from the docking station disposed on the seafloor. In a state where the underwater mobile inspection apparatus is docked with the docking station, a first connector provided on the underwater mobile inspection apparatus is connected to a second connector provided in the docking station, and charging of a battery of the underwater mobile inspection

5

apparatus, transmission of inspection data that has been obtained, or reception of an inspection instruction is performed.

According to the underwater inspection equipment of the present invention, after the underwater mobile inspection apparatus has inspected the inspection object, the underwater mobile inspection apparatus is docked with the docking station disposed on the seafloor, and the first connector of the underwater mobile inspection apparatus is connected to the second connector of the docking station. In this state, charging of the battery of the underwater mobile inspection apparatus, transmission of inspection data that has been obtained, or reception of an inspection instruction can be performed.

In other words, the underwater mobile inspection apparatus can transmit the obtained inspection data to the docking station, and an operator can know inspection results of the inspection object based on the transmitted inspection data. Then, based on a received inspection instruction, the underwater mobile inspection apparatus can perform an inspection of a next inspection object. When the battery of the underwater mobile inspection apparatus has been charged, the underwater mobile inspection apparatus can go on to the inspection of the next inspection object while keeping staying in a submerged state at the seafloor. This makes it possible to reduce a time required for performing the inspections and reduce labor hours.

In the underwater inspection equipment according to the present invention, the underwater mobile inspection apparatus may be configured to store image data in a recording device included in the underwater mobile inspection apparatus, the image data being obtained by capturing an image of the inspection object with the image-capturing camera. In a state where the underwater mobile inspection apparatus is docked with the docking station, the underwater mobile inspection apparatus may transmit the image data.

According to the above configuration, when the underwater mobile inspection apparatus inspects the inspection object, the image-capturing camera captures an image of the inspection object, and image data of the captured image can be stored in the recording device included in the underwater mobile inspection apparatus. Then, in a state where the underwater mobile inspection apparatus is docked with the docking station, the image data stored in the recording device can be transmitted to, for example, an offshore location.

#### Advantageous Effects of Invention

According to the underwater mobile inspection apparatus and underwater inspection equipment of the present invention, the cruising body is configured to submerge under water and cruise along the inspection object in such a manner as not to come into contact with the inspection object. This makes it possible to prevent force based on the mass of the cruising body from being applied to the inspection object. Consequently, damage to the inspection object due to receiving force based on the mass of the cruising body can be prevented. This makes it possible to perform high-speed inspection work while cruising at a high speed.

Even if mechanical tools and devices with great mass that are necessary for the inspection work are loaded on the cruising body, force based on the mass of the cruising body is not applied to the inspection object. Therefore, more mechanical tools and the like can be loaded on the cruising body compared to the conventional art. This makes it

6

possible to improve the quality of various work, including an inspection and cleaning of the inspection object.

The controller is configured to, when the cruising body cruises along the inspection object, operate the first movable arm to move the inspection tool unit, such that the positional relationship of the inspection tool unit with the inspection object becomes a predetermined target positional relationship. Therefore, by means of the inspection tool unit, an inspection of a predetermined target area of the inspection object can be precisely performed. Thus, provided is the underwater mobile inspection apparatus, which makes it possible to improve the quality of various work, including an inspection of the inspection object.

#### BRIEF DESCRIPTION OF DRAWINGS

FIG. 1 is an enlarged side view showing an underwater mobile inspection apparatus according to one embodiment of the present invention.

FIG. 2 is a side view showing a state where the underwater mobile inspection apparatus shown in FIG. 1 inspects an inspection object on the seafloor.

FIG. 3A is a plan view and FIG. 3B is a side view, showing moving paths of a cruising body and an inspection tool unit When the underwater mobile inspection apparatus shown in FIG. 1 inspects an inspection object on the seafloor.

FIG. 4 is a side view of underwater inspection equipment according to the embodiment of the present invention, showing a state where the underwater mobile inspection apparatus is docked with a docking station.

#### DESCRIPTION OF EMBODIMENTS

Hereinafter, one embodiment of an underwater mobile inspection apparatus and underwater inspection equipment according to the present invention is described with reference to FIG. 1 to FIG. 4. As shown in FIG. 1, an underwater mobile inspection apparatus 11 according to the present embodiment is capable of, for example, performing various work while cruising, including an inspection of an inspection object 13 such as a subsea pipeline or a subsea structure. The underwater mobile inspection apparatus 11 makes it possible to prevent damage to the inspection object 13 such as a subsea structure, the damage being due to receiving force based on the mass of a cruising body 14, and improve the quality of various work, including the inspection of the inspection object 13. In the description below, the inspection object 13 is a subsea pipeline,

As shown in FIG. 4, underwater inspection equipment 12 according to the present embodiment includes the underwater mobile inspection apparatus 11 and a docking station 15 disposed on the seafloor. In a state where the underwater mobile inspection apparatus 11 is docked with the docking station 15, charging of a battery of the underwater mobile inspection apparatus 11, transmission of inspection data that has been obtained, and reception of an inspection instruction can be performed.

As shown in FIG. 1, the underwater mobile inspection apparatus 11 includes the cruising body 14, a first movable arm 16, and an inspection tool unit 17.

The cruising body 14 shown in FIG. 1 is, for example, a flat plate-shaped autonomous unmanned underwater vehicle. The cruising body 14 is configured to automatically submerge under water and cruise along the subsea pipeline 13 in such a manner as not to come into contact with the subsea pipeline 13 in accordance with a predetermined

program. The cruising body **14** includes: a main-propulsion thruster **18**; and other thrusters **18** for use in, for example, control of the orientation of the cruising body **14** and delicate correction of the cruising path of the cruising body **14**.

The cruising body **14** includes first and second detectors **19** and **20** for obtaining inspection object information. The inspection object information contains a positional relationship between the cruising body **14** and the subsea pipeline **13**, a positional relationship between the inspection tool unit **17** and the subsea pipeline **13**, and the shape of the subsea pipeline **13**.

The first detector **19** is a multi-beam sonar. As shown in FIG. 1, the first detector **19** is provided at the lower front of the cruising body **14**. The first detector **19** mainly serves to collect inspection object information regarding a forward intermediate distance range. The inspection object information regarding the forward intermediate distance range is information about conditions of the subsea pipeline **13** and its vicinity that are an intermediate distance away, for example, the degree of bending of the subsea pipeline **13** at a forward location that is the intermediate distance away as well as the presence or absence of foreign matter on the pipeline at the forward location.

The second detectors **20** are lasers for use in shape recognition. As shown in FIG. 1, one of the second detectors **20** is disposed at the front bottom surface of the cruising body **14** and the other second detector **20** is disposed at the rear bottom surface of the cruising body **14**, such that the second detectors **20** are spaced apart from each other. These two lasers for shape recognition mainly serve to collect inspection object information regarding a forward short distance range based on a difference between their relative positions. The inspection object information regarding the forward short distance range is information about conditions of the subsea pipeline **13** and its vicinity that are a short distance away, for example, the degree of bending of the subsea pipeline **13** at a forward location that is the short distance away as well as the presence or absence of foreign matter on the pipeline at the forward location.

As shown in FIG. 1, the first movable arm **16** is an articulated robot arm. The proximal end of the first movable arm **16** is connected to the rear of the cruising body **14**, and the inspection tool unit **17** is attached to the distal end of the first movable arm **16**. The first movable arm **16** includes first to third joints **21**, **22**, and **23**. The first joint **21** is provided at the rear of the cruising body **14**. A first parallel link mechanism **24** is provided between the first joint **21** and the second joint **22**. A second parallel link mechanism **25** is provided between the second joint **22** and the third joint **23**. The inspection tool unit **17** is provided at the third joint **23**.

The first joint **21** includes a first frame **26**. The first frame **26** is rotatably connected, via a vertical shaft **29**, to a support protrusion **30** provided at the rear of the cruising body **14**. A first driver (not shown) drives the first frame **26** (first movable arm **16**) to rotate around the vertical shaft **29**.

The first parallel link mechanism **24** includes two parallel links **24a**. One ends of the two respective parallel links **24a** are rotatably connected to the first frame **26** via horizontal shafts **31**. The other ends of the two respective parallel links **24a** are rotatably connected to a second frame **27** via horizontal shafts **32**. A second driver (not shown) drives the first parallel link mechanism **24** to rotate around the horizontal shafts **31**.

The second parallel link mechanism **25** includes two parallel links **25a**. On ends of the two respective parallel links **25a** are rotatably connected to the second frame **27** via

horizontal shafts **33**. The other ends of the two respective parallel links **25a** are rotatably connected to a third frame **28** via horizontal shafts **34**. A third driver (not shown) drives the second parallel link mechanism **25** to rotate around the horizontal shafts **33**.

A fourth driver (not shown) drives the inspection tool unit **17** to rotate around a vertical shaft **52** relative to the third frame **28**.

The inspection tool unit **17** is provided on the third frame **28**.

As shown in FIG. 1, the inspection tool unit **17** is box-shaped. The inspection tool unit **17** accommodates therein control devices for various inspection devices, which will be described below. A pair of second movable arms **35** is provided such that the second movable arms **35** are provided at the left and right side surfaces, respectively, of the inspection tool unit **17**. First and second image-capturing cameras (e.g., video cameras) **36** are provided on the distal ends of the pair of respective second movable arms **35**.

The first and second image-capturing cameras **36** are configured to capture images of the left and right side surfaces of the subsea pipeline **13**. The captured images allow an operator to visually inspect the left and right side surfaces of the pipeline.

Moreover, as shown in FIG. 1, a third image-capturing camera **37** is provided on the front surface of the inspection tool unit **17** via a bracket **38**. The third image-capturing camera **37** is configured to capture an image of the upper surface of the subsea pipeline **13**. The captured image allows the operator to visually inspect the upper surface of the pipeline.

As shown in FIG. 1, the inspection tool unit **17** further includes an anti-corrosion inspection device **39** and a wall thickness inspection device (not shown).

The anti-corrosion inspection device **39** serves to inspect the degree of degradation of anti-corrosion treatment (e.g., anti-corrosion coating) of the subsea pipeline **13** for its overall length. The anti-corrosion inspection device **39** includes a potential measurement probe **39a** and a remote electrode **39b**. The potential measurement probe **39a** is provided on the inspection tool unit **17** via the bracket **38**. The distal end of the potential measurement probe **39a** is positioned near the upper surface of the pipeline **13**. The remote electrode **39b** is connected to the distal end of a linear object **41** which is reeled out from an electrode winch **40** provided on the cruising body **14**.

FIG. 1 shows a state where the anti-corrosion inspection device **39** is not in use. In FIG. 1, the electrode winch **40** is in a state of reeling in the linear object **41**, and the remote electrode **39b** is fixed to a vertical tail **42** of the cruising body **14**. FIG. 2 shows a state where the anti-corrosion inspection device **39** is in use. In FIG. 2, the electrode winch **40** is in a state of reeling out the linear object **41**, and the remote electrode **39b** is placed at a position that is a predetermined distance away from the vertical tail **42** of the cruising body **14**.

The wall thickness inspection device is a known conventional device, for example, a device configured to inspect the wall thickness of the subsea pipeline **13** for its overall length by using ultrasonic waves. Accordingly, the degree of corrosion of the subsea pipeline **13** and the presence or absence of damage to the subsea pipeline **13** can be inspected.

As shown in FIG. 1, the inspection tool unit **17** is provided with a running part **43** configured to allow the inspection tool unit **17** to run on the subsea pipeline **13** in such a manner as to contact the subsea pipeline **13**. The running part **43** is realized by, for example, rolling portions such as wheels.

However, as an alternative, the running part **43** may include not only rolling portions such as wheels but also, for example, a sliding portion that allows the inspection tool unit **17** to slidably move over the subsea pipeline **13**.

Next, a description is given of a controller (not shown) included in the cruising body **14**. The controller controls the cruising body **14** based on the inspection object information, such that the cruising body **14** autonomously cruises along the subsea pipeline **13** in such a manner as not to come into contact with the subsea pipeline **13**.

As described above, the inspection object information is obtained by the first and second detectors **19** and **20**. The inspection object information contains a positional relationship between the cruising body **14** and the subsea pipeline **13** as well as the shape of the pipeline.

The controller is configured to, when the cruising body **14** cruises based on the inspection object information along the subsea pipeline **13** in such a manner as not to come into contact with the subsea pipeline **13** as described above, operate the first movable arm **16** based on the same inspection object information to move the inspection tool unit **17**, such that the positional relationship of the inspection tool unit **17** with the subsea pipeline **13** becomes a predetermined target positional relationship.

Moreover, the controller is configured to operate the pair of second movable arms **35** shown in FIG. 1 based on the inspection object information obtained by the first and second detectors **19** and **20**, thereby moving the first and second image-capturing cameras **36** to their target positions. Specifically, the controller operates the second movable arms **35** to move the first and second image-capturing cameras **36** toward their target positions in accordance with, for example, the diameter of the subsea pipeline **13**. That is, the controller can perform automatic correction of the positions of the first and second image-capturing cameras **36**.

Furthermore, the controller is configured to operate the first movable arm **16** by force feedback control, such that the inspection tool unit **17**, which runs on the subsea pipeline **13** shown in FIG. 1 in such a manner as to contact the subsea pipeline **13**, is in pressure contact with the subsea pipeline **13** with predetermined force. In order to realize the force feedback control, the running part **43** (wheels) is provided with a load detector (not shown).

The load detector is configured to detect the pressure contact force of the inspection tool unit **17** against the subsea pipeline **13**. The controller is configured to control the motion of the first movable arm **16**, such that the detected force becomes target pressing force which is set in advance.

Next, functions of the underwater mobile inspection apparatus **11** with the above-described configuration are described. According to the underwater mobile inspection apparatus **11** shown in FIG. 1, in accordance with a preset program, the cruising body **14** can submerge under water and autonomously cruise along the subsea pipeline **13** in such a manner as not to come into contact with the subsea pipeline **13**. At the time, the inspection tool unit **17** provided on the cruising body **14** via the first movable arm **16** can be controlled to follow the cruising body **14**. Dashed lines **44** shown in FIG. 3A and FIG. 3B are cruising paths of the cruising body **14**.

Specifically, the cruising body **14** can autonomously cruise along the subsea pipeline **13** in such a manner as not to come into contact with the subsea pipeline **13**, because, for example, a map showing the installation location of the subsea pipeline **13** is stored in a memory of the controller, and the cruising of the cruising body **14** is controlled based

on the pipeline installation location information indicated by the map and inspection object information.

When the cruising body **14** cruises along the subsea pipeline **13** in such a manner as not to come into contact with the subsea pipeline **13**, the controller operates the first movable arm **16** to move the inspection tool unit **17**, such that the positional relationship of the inspection tool unit **17** with the subsea pipeline **13** becomes a target positional relationship which is set in advance.

The target positional relationship of the inspection tool unit **17** with the subsea pipeline **13** is, as indicated by dashed lines **45** in FIG. 3A and FIG. 3B, a positional relationship in which the inspection tool unit **17** is positioned substantially right above the central axis of the subsea pipeline **13** and runs on the subsea pipeline **13** in a state of being in contact with the upper surface of the subsea pipeline **13**.

As described above, the cruising body **14** is configured to submerge under water and cruise along the subsea pipeline **13** in such a manner as not to come into contact with the subsea pipeline **13**. This makes it possible to prevent the weight of the cruising body **14** and inertial force exerted on the cruising body **14** from being applied to the subsea pipeline **13**. Consequently, damage to the subsea pipeline **13** due to receiving the weight of the cruising body **14** and the inertial force exerted on the cruising body **14** can be prevented. This makes it possible to perform high-speed inspection work while cruising at a high speed.

Moreover, even if heavy-weight mechanical tools and devices necessary for the inspection work are loaded on the cruising body **14**, force based on the mass of the cruising body **14** is not applied to the subsea pipeline **13**. Therefore, more mechanical tools and the like can be loaded on the cruising body **14** compared to the conventional art. This makes it possible to improve the quality of various work, including an inspection and cleaning of the subsea pipeline **13**.

Furthermore, the controller is configured to, when the cruising body **14** cruises along the subsea pipeline **13**, operate the first movable arm **16** to move the inspection tool unit **17**, such that the positional relationship of the inspection tool unit **17** with the subsea pipeline **13** becomes a predetermined target positional relationship. Therefore, by means of the inspection tool unit **17**, an inspection of a predetermined target area of the subsea pipeline **13** (in the present embodiment, the left side surface, the right side surface, and the upper surface of the subsea pipeline **13** are the predetermined target area) can be precisely performed. Thus, provided is the underwater mobile inspection apparatus **11**, which makes it possible to improve the quality of various work, including an inspection and cleaning of the subsea pipeline **13**.

In the present embodiment, the left side surface, the right side surface, and the upper surface of the subsea pipeline **13** are to be inspected. However, the inspection may be additionally performed on, for example, the lower surface of the subsea pipeline **13**.

As described above, the cruising body **14** includes the controller. The controller can control the cruising body **14** based on the inspection object information obtained by the first and second detectors **19** and **20** so that the cruising body **14** will autonomously cruise along the subsea pipeline **13** in such a manner as not to come into contact with the subsea pipeline **13**, which is, for example, bent as shown in FIGS. 3A and 3B.

The inspection object information is information containing, for example, a positional relationship between the cruising body **14** and the subsea pipeline **13** as well as the

## 11

shape of the pipeline 13. The inspection object information is, for example, information about the degree of bending of the pipeline 13 and information about the presence or absence of foreign matter on the pipeline 13.

Since the cruising body 14 is configured to autonomously cruise along the subsea pipeline 13, it is not necessary to remote-control the underwater mobile inspection apparatus 11 from an offshore support ship, and the subsea pipeline 13 can be inspected automatically. This makes it possible to reduce labor hours, labor costs, and costs of the support ship for inspecting the subsea pipeline 13.

Further, when the cruising body 14 autonomously cruises along the subsea pipeline 13 in such a manner as not to come into contact with the subsea pipeline 13, the controller can operate the second movable arms 35 shown in FIG. 1 based on the inspection object information to move the first and second image-capturing cameras 36, such that the positional relationship of the first and second image-capturing cameras 36 with the subsea pipeline 13 becomes a predetermined target positional relationship.

The above configuration allows the first to third image-capturing cameras 36 and 37 to precisely capture images of the external view of the predetermined target area of the subsea pipeline 13. By visually confirming image data of the captured images, an operator is allowed to perform precise visual inspection of the subsea pipeline 13.

The target positional relationship of the first and second image-capturing cameras 36 with the subsea pipeline 13 is, as shown in FIG. 1, a positional relationship in which the first and second image-capturing cameras 36 are in such positions as to be able to capture images of the left and right side surfaces of the subsea pipeline 13.

The target positional relationship of the third image-capturing camera 37 with the subsea pipeline 13 is, as shown in FIG. 1, a positional relationship in which the third image-capturing camera 37 is in such a position as to be able to capture an image of the upper surface of the subsea pipeline 13.

As shown in FIG. 1, the inspection tool unit 17 includes the anti-corrosion inspection device 39 and the wall thickness inspection device (not shown). Therefore, when the underwater mobile inspection apparatus 11 submerges under water and cruises along the subsea pipeline 13 in such a manner as not to come into contact with the subsea pipeline 13, for example, the degree of degradation of the anti-corrosion treatment (e.g., anti-corrosion coating) of the subsea pipeline 13 can be automatically inspected by using the anti-corrosion inspection device 39. In addition, the wall thickness of the subsea pipeline 13 can be automatically inspected by using the wall thickness inspection device. Thus, the degree of corrosion of the subsea pipeline 13 and the presence or absence of damage to the subsea pipeline 13 can be inspected.

When an anti-corrosion potential measurement device is used as the anti-corrosion inspection device 39 as shown in FIG. 2, first, the linear object 41 is reeled out from the electrode winch 40 of the cruising body 14 by a predetermined length, and the remote electrode 39b connected to the linear object 41 is moved away from the potential measurement probe 39a of the inspection tool unit 17 by a predetermined distance. Next, a potential difference between the potential measurement probe 39a positioned near the subsea pipeline 13 and the remote electrode 39b is measured. Based on the measured potential difference, the degree of the anti-corrosion protection (i.e., the degree of corrosion) of the subsea pipeline 13 can be inspected.

## 12

The electrode winch 40 for reeling in or out the linear object 41 to which the remote electrode 39b of the anti-corrosion inspection device 39 is connected is provided on the cruising body 14. Since the cruising body 14 can cruise along the subsea pipeline 13 in such a manner as not to come into contact with the subsea pipeline 13, damage to the subsea pipeline 13 due to force based on the mass of the cruising body 14 including the electrode winch 40 can be prevented.

Further, as shown in FIG. 1, the first movable arm 16 includes the first and second parallel link mechanisms 24 and 25. This makes it possible to reduce a necessary number of joints of the first movable arm 16 for the controller to operate the first movable arm 16 to move the inspection tool unit 17 such that the positional relationship of the inspection tool unit 17 with the subsea pipeline 13 becomes a predetermined target positional relationship. As a result, a compact and light-weight first movable arm 16 can be provided, and also, the control of the first movable arm 16 can be readily performed.

As shown in FIG. 1, the inspection tool unit 17 is provided with the running part 43 (wheels), which allows the inspection tool unit 17 to run on the subsea pipeline 13. Accordingly, the inspection tool unit 17 can run on the subsea pipeline 13 while following the cruising of the cruising body 14. Since the inspection tool unit 17 runs on the subsea pipeline 13, the subsea pipeline 13 serves to assist in guiding the inspection tool unit 17 to be in a predetermined target positional relationship with the subsea pipeline 13.

The controller is configured to operate the first movable arm 16 by force feedback control, such that the inspection tool unit 17 is in pressure contact with the subsea pipeline 13 with predetermined force. Therefore, even though there is the weight of the inspection tool unit 17 as well as inertial force exerted on the inspection tool unit 17, force applied to the subsea pipeline 13 can be controlled to be predetermined target pressing force. This consequently makes it possible to prevent a situation where the subsea pipeline 13 receives force based on the mass of the cruising body 14 and thereby becomes damaged.

Further, by using wheels as the running part 43 of the inspection tool unit 17, the body of the inspection tool unit 17 can be assuredly prevented from coming into contact with the subsea pipeline 13, and thereby damage to the inspection tool unit 17 due to such contact can be prevented.

Next, the underwater inspection equipment 12 is described with reference to FIG. 4. The underwater inspection equipment 12 shown in FIG. 4 includes the underwater mobile inspection apparatus 11 and the docking station 15 disposed on the seafloor.

The docking station 15 includes a substantially parallel-epiped cage-like unit 46. The underwater mobile inspection apparatus 11 enters the inside of the cage-like unit 46 where the underwater mobile inspection apparatus 11 can be docked. A second connector 48 is provided on a floor 46a of the cage-like unit 46.

As shown in FIG. 4, the underwater mobile inspection apparatus 11 can be docked with and unlocked from the docking station 15 disposed on the seafloor. In a state where the underwater mobile inspection apparatus 11 is docked with the docking station 15, a first connector 47 provided on the underwater mobile inspection apparatus 11 is connected to the second connector 48 provided in the docking station 15 so that charging of a battery included in the cruising body 14 of the underwater mobile inspection apparatus 11, transmission of inspection data that has been obtained, and reception of an inspection instruction can be performed.

13

For example, the docking station **15** is suspended by a rope **49** from an offshore production base. The rope **49** is reeled in or out by a hoist (not shown). Accordingly, the docking station **15** is lifted and lowered by the hoist, and thereby the docking station **15** can be drawn up onto the offshore production base or set on a seafloor **50**.

The offshore production base and the docking station **15** are connected to each other by a cable **51**. Via the cable **51**, electric power for use in charging the battery can be supplied, and an inspection instruction can be transmitted, from the offshore production base to the docking station **15**. Moreover, inspection data obtained by the underwater mobile inspection apparatus **11** can be transmitted from the docking station **15** to the offshore production base via the cable **51**. The second connector **48** of the docking station **15** is connected to the cable **51**. The offshore production base is, for example, a petroleum gas production rig or a floating crude oil production, storage and offloading facility.

According to the underwater inspection equipment **12** shown in FIG. 4, after the underwater mobile inspection apparatus **11** has inspected the subsea pipeline **13**, the underwater mobile inspection apparatus **11** is docked with the docking station **15** disposed on the seafloor **50**, and the first connector **47** of the underwater mobile inspection apparatus **11** is connected to the second connector **48** of the docking station **15**. In this state, charging of the battery of the underwater mobile inspection apparatus **11**, transmission of inspection data that has been obtained, and reception of an inspection instruction can be performed.

In other words, the underwater mobile inspection apparatus **11** can transmit the obtained inspection data to the offshore production base via the docking station **15**, and an operator can know inspection results of the subsea pipeline **13** based on the transmitted inspection data. Then, based on a received inspection instruction, the underwater mobile inspection apparatus **11** can perform an inspection of, for example, a next subsea pipeline **13**. When the battery of the underwater mobile inspection apparatus **11** has been charged, the underwater mobile inspection apparatus **11** can go on to the inspection of, for example, the next subsea pipeline **13** while keeping staying in a submerged state at the seafloor. This makes it possible to reduce a time required for performing the inspections and reduce labor hours.

The underwater mobile inspection apparatus **11** included in the underwater inspection equipment **12** shown in FIG. 4 is configured to store inspection data in a recording device (not shown) included in the cruising body **14** of the underwater mobile inspection apparatus **11**, the inspection data containing image data that is obtained by capturing images of the subsea pipeline **13** with the first to third image-capturing cameras **36** and **37**. In a state where the underwater mobile inspection apparatus **11** is docked with the docking station **15**, or after the underwater mobile inspection apparatus **11** is docked with the docking station **15**, the inspection data containing the image data can be transmitted to the offshore production base via the cable **51** of the docking station **15**.

According to the underwater inspection equipment **12**, when the underwater mobile inspection apparatus **11** inspects the subsea pipeline **13**, the first to third image-capturing cameras **36** and **37** capture images of the subsea pipeline **13**, and inspection data containing image data of the captured images can be stored in the recording device included in the underwater mobile inspection apparatus **11**. Then, in a state where the underwater mobile inspection apparatus **11** is docked with the docking station, or after the underwater mobile inspection apparatus **11** is docked with

14

the docking station, the inspection data stored in the recording device, which contains the image data, can be transmitted to, for example, an offshore location via the cable **51**.

Although the above embodiment has been described by taking a subsea pipeline as an example of the inspection object **13**, the inspection object **13** is not limited to a subsea pipeline, but may be, for example, a submarine electrical cable laid on the seafloor or a subsea structure such as a jacket.

In the above-described embodiment, the underwater mobile inspection apparatus **11** cruises along the subsea pipeline **13**, and while cruising, inspects the subsea pipeline **13** by means of the inspection tool unit **17**. However, as an alternative, the underwater mobile inspection apparatus **11** may inspect a facility or a building built on the seafloor.

Further, in the above-described embodiment, as shown in FIG. 1, the inspection tool unit **17** is provided with the wheels **43**. The inspection tool unit **17** inspects the subsea pipeline **13** while running on the subsea pipeline **13** in such a manner as to contact the subsea pipeline **13** via the wheels **43**. However, the inspection tool unit **17** need not be provided with the wheels **43**, and the inspection tool unit **17** may inspect the subsea pipeline **13** while moving along the subsea pipeline **13** in such a manner as not to come into contact with the subsea pipeline **13**.

Also in this case, the controller is configured to control the first movable arm **16** such that the positional relationship of the inspection tool unit **17** with the subsea pipeline **13** becomes a predetermined target positional relationship.

If the inspection tool unit **17** performs the inspection of the subsea pipeline **13** in such a non-contact manner as above, a situation where the subsea pipeline **13** receives the weight of the inspection tool unit **17** and inertial force exerted on the inspection tool unit **17** and thereby becomes damaged can be prevented. This makes it possible to perform faster inspection work by faster cruising.

Further, in the above-described embodiment, the cruising body **14** is not remote-controlled but cruises autonomously. However, as an alternative, a cable may be connected to the cruising body, and an operator may remote-control the cruising body via the cable from an offshore location or from the ground to inspect the subsea pipeline **13**.

#### INDUSTRIAL APPLICABILITY

As described above, the underwater mobile inspection apparatus and underwater inspection equipment according to the present invention make it possible to prevent damage to an inspection object such as a subsea structure, the damage being due to receiving force based on the mass of the cruising body, and provide an excellent advantage of improving the quality of various work, including an inspection of the inspection object. Thus, the present invention is suitably applicable to underwater mobile inspection apparatuses and underwater inspection equipment.

#### REFERENCE SIGNS LIST

- 11** underwater mobile inspection apparatus
- 12** underwater inspection equipment
- 13** inspection object (subsea pipeline)
- 14** cruising body
- 15** docking station
- 16** first movable arm
- 17** inspection tool unit
- 18** thruster
- 19** fist detector

20 second detector  
 21 first joint  
 22 second joint  
 23 third joint  
 24 first parallel link mechanism  
 24a parallel link  
 25 second parallel link mechanism  
 25a parallel link  
 26 first frame  
 27 second frame  
 28 third frame  
 29 vertical shaft  
 30 support protrusion  
 31, 32, 33, 34 horizontal shaft  
 35 second movable arm  
 36 first and second image-capturing cameras  
 37 third image-capturing camera  
 38 bracket  
 39 anti-corrosion inspection device  
 39a potential measurement probe  
 39b remote electrode  
 40 electrode winch  
 41 linear object  
 42 vertical tail  
 43 running part (wheels)  
 44 dashed line indicating a cruising path  
 45 dashed line indicating a running path  
 46 cage-like unit  
 46a floor  
 47 first connector  
 48 second connector  
 49 rope  
 50 seafloor  
 51 cable  
 52 vertical shaft  
 What is claimed is:  
 1. An underwater mobile inspection apparatus capable of inspecting an inspection object on a seafloor while cruising, the underwater mobile inspection apparatus comprising:  
 a cruising body configured to submerge under water and cruise along the inspection object in such a manner as not to come into contact with the inspection object;  
 a first movable arm provided on the cruising body;  
 an inspection tool unit for use in inspecting the inspection object, the inspection tool unit being provided on the first movable arm; and  
 a controller configured to, when the cruising body cruises along the inspection object in such a manner as not to come into contact with the inspection object, operate the first movable arm to move the inspection tool unit, such that a positional relationship of the inspection tool unit with the inspection object becomes a predetermined target positional relationship, wherein the controller:  
 stores a map showing an installation location of the inspection object; and  
 controls the cruising body based on installation location information indicated by the map, the installation location information specifying the installation location of the inspection object, such that the cruising body autonomously cruises along the inspection object in such a manner as not to come into contact with the inspection object.  
 2. The underwater mobile inspection apparatus according to claim 1, wherein the cruising body includes an inspection object detector configured to obtain inspection object information con-

taining a positional relationship between the cruising body and the inspection object and a shape of the inspection object, and  
 the controller controls the cruising body based on the installation location information and the inspection object information, such that the cruising body autonomously cruises along the inspection object in such a manner as not to come into contact with the inspection object.  
 3. The underwater mobile inspection apparatus according to claim 1, comprising:  
 an inspection object detector included in the cruising body and configured to obtain inspection object information containing a positional relationship between the inspection tool unit and the inspection object and a shape of the inspection object;  
 a second movable arm provided on the inspection tool unit; and  
 an image-capturing camera for use in visually inspecting the inspection object, the image-capturing camera being provided on the second movable arm, wherein the controller controls the second movable arm based on the inspection object information, such that a positional relationship of the image-capturing camera with the inspection object becomes a predetermined target positional relationship.  
 4. The underwater mobile inspection apparatus according to claim 1, wherein the inspection tool unit includes at least one of an anti-corrosion inspection device and a wall thickness inspection device.  
 5. The underwater mobile inspection apparatus according to claim 4, wherein the anti-corrosion inspection device includes an anti-corrosion potential measurement device, and the anti-corrosion potential measurement device includes:  
 a potential measurement probe provided on the inspection tool unit; and  
 a remote electrode connected to a linear object reeled out from an electrode winch provided on the cruising body.  
 6. The underwater mobile inspection apparatus according to claim 1, wherein the first movable arm includes a parallel link mechanism.  
 7. The underwater mobile inspection apparatus according to claim 1, wherein the inspection tool unit is provided with a running part configured to allow the inspection tool unit to run on the inspection object, and the controller operates the first movable arm by force feedback control, such that the inspection tool unit is in pressure contact with the inspection object with predetermined target pressing force.  
 8. The underwater mobile inspection apparatus according to claim 7, wherein the running part is a wheel.  
 9. Underwater inspection equipment comprising:  
 the underwater mobile inspection apparatus according to claim 1; and  
 a docking station disposed on a seafloor, wherein the underwater mobile inspection apparatus is configured to be docked with and undocked from the docking station disposed on the seafloor, and in a state where the underwater mobile inspection apparatus is docked with the docking station, a first connector provided on the underwater mobile inspection apparatus is connected to a second connector provided in the docking station, and charging of a battery of the underwater mobile inspection apparatus, transmission

17

of inspection data that has been obtained, or reception of an inspection instruction is performed.

10. The underwater inspection equipment according to claim 9, comprising an underwater mobile inspection apparatus including:

an inspection object detector included in the cruising body and configured to obtain inspection object information containing a positional relationship between the inspection tool unit and the inspection object and a shape of the inspection object

a second movable arm provided on the inspection tool unit and

an image-capturing camera for use in visually inspecting the inspection object, the image-capturing camera being provided on the second movable arm, wherein

the controller controls the second movable arm based on the inspection object information, such that a positional relationship of the image-capturing camera with the inspection object becomes a predetermined target positional relationship; wherein

the underwater mobile inspection apparatus is configured to store image data in a recording device included in the underwater mobile inspection apparatus, the image data

18

being obtained by capturing an image of the inspection object with the image-capturing camera, and in a state where the underwater mobile inspection apparatus is docked with the docking station, the underwater mobile inspection apparatus transmits the image data.

11. The underwater mobile inspection apparatus according to claim 2, comprising:

an inspection object detector included in the cruising body and configured to obtain inspection object information containing a positional relationship between the inspection tool unit and the inspection object and a shape of the inspection object;

a second movable arm provided on the inspection tool unit; and

an image-capturing camera for use in visually inspecting the inspection object, the image-capturing camera being provided on the second movable arm, wherein the controller controls the second movable arm based on the inspection object information, such that a positional relationship of the image-capturing camera with the inspection object becomes a predetermined target positional relationship.

\* \* \* \* \*