

①②

EUROPEAN PATENT APPLICATION

②① Application number: **88304541.1**

⑤① Int. Cl.4: **E06B 1/70 , E06B 7/16 ,
E06B 7/23**

②② Date of filing: **19.05.88**

③① Priority: **16.11.87 US 121105**

④③ Date of publication of application:
31.05.89 Bulletin 89/22

⑥④ Designated Contracting States:
AT BE CH DE ES FR GB GR IT LI LU NL SE

⑦① Applicant: **Slater, James T.**
3002 Bethany Church Road
Lithonia Georgia 30058(US)

Applicant: **McConnell, Michael J.**
3740 Martin Farm Road
Suwanee Georgia 30174(US)

⑦② Inventor: **Slater, James T.**
3002 Bethany Church Road
Lithonia Georgia 30058(US)
Inventor: **McConnell, Michael J.**
3740 Martin Farm Road
Suwanee Georgia 30174(US)

⑦④ Representative: **Wilson, Nicholas Martin et al**
WITHERS & ROGERS 4 Dyer's Buildings
Holborn
London EC1N 2JT(GB)

⑤④ **Threshold assembly for garage doors.**

⑤⑦ A threshold assembly for receiving the weatherstrip (18) commonly applied to the bottom edge of garage doors is disclosed, the threshold assembly including a threshold plate (16) member with a generally inverted V-shape. The member has a generally flat base (30) for securing to the slab and an upper surface with sloping front and rear portions (38,44) serving as a receiving surface for the weatherstrip and a transitional ramp, respectively.

EP 0 318 130 A1

BACKGROUND OF THE INVENTION

Overhead garage doors are sometimes equipped with a seal or weatherstrip which is attached to the bottom surface of the door and is designed to contact the driveway or garage floor to prevent or minimize water intrusion and wind infiltration. Such seals are normally designed to rest directly on the concrete, asphalt, or other driveway surface and, in general, present either an inverted U-shape or a rounded or oblong cross-sectional configuration. Both typical shapes are normally compressed by the weight of the door to effect sealing with the underlying pavement.

Weatherstripping of this type must endure wide temperature swings of the underlying pavement as well as shock loads imposed by the garage doors upon their closing. Temperatures may vary greatly in a single day as well as from season to season. In northern climates, problems are often experienced with the weatherstripping freezing to the concrete slab and then tearing as the door is opened. Shock loads may also vary greatly depending on factors such as overall door weight and the method of closing the door, i.e. automatic closing or manual closing.

For these and other reasons, weatherstripping such as that described above normally has a limited life span. As the product deteriorates, infiltration from moisture, wind, insects and even rodents becomes a problem which normally can only be remedied successfully by replacement as repair is generally not a viable option. In addition, replacement is generally difficult or awkward due to the position of the weatherstripping, i.e. on the bottom of the door, as well as from frozen or rusted fasteners which hinder removal of the damaged product. Where deterioration of the seal is significant, replacement may be further hindered by deterioration or rotting of the door itself, which may require repair or partial replacement of the lower edge of the door before a new seal can be installed.

SUMMARY OF THE INVENTION

It is, therefore, one of the principal objects of the present invention to provide a threshold assembly for garage doors which cooperates with the various forms of weatherstripping and prevents infiltration of moisture, wind, insects, rodents and other forces, providing a threshold as a base for

the weatherstripping applied to the bottom of the garage door, thereby sealing the door and preventing contact of the weatherstrip with the underlying pavement.

Another object of the present invention is to provide a threshold assembly which resists deterioration from temperature extremes, ultraviolet rays, and ozone gas, and which maintains flexibility despite harsh conditions.

A further object of the present invention is to provide a threshold for the weatherstripping which is highly resistant to shock loads from driving over the threshold and which, in combination with the weatherstripping provides a cooperative sealing assembly, the threshold assembly being durable for providing a long service life.

These and additional objects are attained by the present invention which relates to a threshold assembly for garage doors having a threshold plate means with a bottom surface designed for sealing to the underlying pavement and an upper surface designed for cooperatively accepting the conventional weatherstripping applied to the bottom of the garage door, thereby sealing the bottom of the door. The upper surface of the threshold is also designed to minimize shock loads from vehicles driven thereover in either direction, having surface portions sloping away from the approximate center in both directions. The weatherstripping attached to the bottom of the garage door may have, in general, a tubular or inverted U-shape which the present invention receives on the outer sloping surface.

The present invention may be composed of a number of suitable materials, such as, for example, a thermoplastic elastomer, a preferred material being a PVC vinyl product which is flexible and resistant to UV and ozone degradation and chemical substances such as oil and gasoline which might come into contact with the threshold. The invention is also relatively inexpensive to produce and install, with no specialized tools or experience required.

Various additional objects and advantages will become apparent from the following description, with reference to the accompanying drawings.

BRIEF DESCRIPTION OF THE DRAWINGS

Figure 1 is a perspective view, shown with a partial cutaway cross-section, of the present invention in installed position; and

Figure 2 is a side elevational and cross-sectional view of the present invention in installed position, the garage door and weatherstripping being shown in phantom lines.

DETAILED DESCRIPTION OF THE PREFERRED EMBODIMENT

Referring now more specifically to the drawings, and to Figure 1 in particular, numeral 10 designates generally a typical garage door, shown in closed position in garage 12. The door shown is of the sectional type, with individual panels 14 pivotally mounted so as to follow a curved track when raising or lowering the door. This is not meant to limit the invention in any way, as the present assembly may also be used with unitary garage doors which swing outwardly from their base mounting when the door is raised and in residential or commercial use.

The invention involves the cooperative functioning of a base plate means or threshold 16 and a conventional weatherstrip means 18. The weatherstrip may have, in general, an inverted U-shaped or tubular configuration and is secured to the lowermost or bottom edge 20 of the garage door with a suitable securing means, such as rivets 22 or screws. The rivets or the like are inserted through the weatherstrip and into the door at suitable selected intervals usually along the approximate center of the main body portion 24 of the weatherstrip. The threshold itself is normally approximately 3 1/4" wide from front to back to minimize the profile presented to the sun and other degradative forces as most of the width located outside the plane of the garage door is covered by the weatherstrip.

The leg portions of the weatherstrip include a front leg 26 and a rear leg 28, the front leg being disposed on the side of the weatherstrip which extends outwardly from the interior of the garage. The front leg illustrated here is longer than the rear leg, as shown in Figure 2, however, the present threshold also accepts weatherstripping having legs of equal lengths or tubular forms as discussed hereinbelow.

Threshold member 16 has in general, an inverted V-shaped configuration with a generally flat bottom side or base 30. The base is provided with a plurality of inverted V-shaped grooves 32, which are designed to receive and hold a suitable securing means such as adhesive material 34 for securing the threshold to the slab 36. The grooves are concentrated in the central portion of the threshold,

thereby helping to maintain needed flexibility in the front and rear portions adjacent the central portion. The combination of adhesive in the normally porous concrete or asphalt slab and in the centralized grooves provides a very effective holding assembly without sacrificing the flexibility of the sloping portions which bear the brunt of the load from the vehicles driving thereover. As shown in Figure 2, the front portion or side of the base, which extends radially outwardly from the interior of the garage, has a sloping upper surface 38 with a relatively low pitch. This upper surface 38 graduates to a steeply pitched wall portion 40, which serves as a dam for rain water and the like and also as a guide for the weatherstrip as it descends. As the door is lowered, the rear leg 28 is guided into the approximate 45° angle where wall 40 and sloped surface 38 intersect and the front leg 26 is caused to flex into a slightly concave configuration to aid in water runoff.

Continuous with wall portion 40 is generally flattened surface 42 at the apex of the inverted V-shaped threshold 16. Extending radially from surface 42 toward the interior of the garage is the rear portion or ramp 44 which serves as a transition from the garage floor to the sloping upper surface 38. The pitch is increased from that of surface portion 38 to provide the requisite height for the damming effect of wall 40 and also to act as a wedge to drive the threshold against the slab downwardly as opposed to laterally or radially, under the pressure of vehicle tires passing thereover.

The threshold 16 may be produced from a number of suitable materials, a preferred composition being a thermoplastic elastomer. The elastomer, which is more specifically a flexible PVC vinyl, may be, for example, a product sold under the trademark GEON 8804 by B.F. Goodrich Co., or products manufactured by Tenneco and sold under the numerical designations #2025 or #1280. These products and other similar vinyl products, polyurethanes, or copolyesters and even some natural or synthetic rubbers, are chosen for resistance to ultraviolet and ozone degradation and resistance to attack from oil, gasoline, and other common chemicals which might be picked up by tires on the road or in a garage. Other qualities include flexibility and stability at both low temperatures of -30° F to -40° F and high temperatures ranging from 140° F to 250° F.

Ultraviolet degradation is minimized normally by the addition of carbon black in quantities of approximately 2% to 2.5% by weight. Further stability against UV degradation and brittleness at cold temperatures is provided by the addition of a clay filler to the basic compounds. Setting of the PVC compound, preferred over the polyurethanes and copolyesters mainly due to cost considerations, is

accomplished during the production period, thus eliminating any shrinkage problems after installation. Painting of the material may be accomplished if desired with a suitable vinyl spray paint.

The PVC material has a shore durometer rating ranging from approximately 70A to 90A and an ASTM D 746 Brittle point of approximately -30° F. Tensile strength may range from approximately 1700 to 3000 psi. The adhesive used to secure the threshold to the base slab may be any of a number of suitable types compatible with the material used for the threshold, for example, a structural adhesive. The adhesive is chosen for properties of stability at temperature extremes, volatility, allowing its application in temperature extremes, and the ability to fill and grip the normally porous concrete or asphalt surface while bonding the threshold to the slab.

In the use and operation of the present threshold assembly, installation is accomplished by raising the garage door slightly, approximately 1/4". The threshold is then slid under the existing weatherstrip until contact with the weatherstrip is made. The edges are marked, and the door is fully raised for installation clearance. The adhesive is deposited within the marked area and the threshold is pressed into place.

A further advantage is the support provided for the garage door by the present threshold which helps to prevent or minimize sagging or bowing of the garage door, especially where the door has significant weight and/or length. Such conditions lead to early failure of the door from the stress imparted thereto. Thus, support is provided by the threshold along the entire length of the door in both lateral and radial directions.

As shown in Figure 2, the threshold has a low profile to minimize the friction of vehicle tires passing thereover, thereby minimizing the possibility of the threshold moving after installation, and also to facilitate flushing out or sweeping out the garage floor. The profile is sufficiently raised, however, to provide a significant damming effect against moisture, rain or snow, dust and other forces. Further protection against UV degradation is provided by the shielding effect of the weatherstrip 18 which covers most of the exposed surface 38 of the threshold when the garage door is closed. The weatherstrip is protected from temperature extremes due to the insulative qualities of the threshold and adhesive which prevent contact between the weatherstrip and the slab. Thus, a significant advance in weatherproofing is provided by the present invention, with an inherently stable product that is easy to apply and which provides a long service life.

While an embodiment and modifications of a cooperative threshold and weatherstripping assem-

bly for garage doors has been shown and described in detail herein, various additional modifications may be made without departing from the scope of the present invention.

Claims

1. A threshold assembly for a garage door, for receiving a weatherstrip means secured to the lowermost edge of said garage door, said threshold means designed for installation over the slab and beneath said weatherstrip when said door is in a closed position, said threshold comprising a generally inverted V-shaped member with a generally flat base for contacting the slab, said threshold also including an apex forming a dam for blocking intrusion of rain, wind, and the like with front and rear portions extending away from the interior of the garage and toward the interior of the garage, respectively, said front portion having an upper surface sloping downwardly from said apex for receiving and seating said weatherstrip and said rear portion having an upper surface sloping downwardly in the opposite direction from said apex for providing a ramp between the garage floor and said upper surface of said front portion, and a securing means disposed between said base of said threshold and the slab.

2. A threshold assembly as defined in Claim 1 in which said securing means includes an adhesive for affixing said threshold to the slab.

3. A threshold assembly as defined in Claim 2 in which said base includes a plurality of groove means formed therein for receiving said adhesive.

4. A threshold assembly as defined in Claim 3 in which said threshold includes a steeply pitched wall portion extending between said sloping front portion and said apex for providing a dam against wind and water ingress.

5. A threshold assembly as defined in Claim 1 in which said threshold includes a steeply pitched wall portion extending between said sloping front portion and said apex for providing a dam against wind and water ingress.

6. A threshold assembly for receiving a weatherstrip means secured to the bottom edge of a garage door, said threshold assembly comprising an generally inverted V-shaped member of solid cross-section having a generally flat base with an adhesive means disposed thereon for securing said base to the garage floor, said V-shaped member having a central portion with an apex, a steeply pitched wall portion extending downwardly from said apex toward the outside of the garage door, a relatively lower pitched front portion extending radially away from said wall portion for receiving said weatherstrip, and a rear portion extending radially

from said apex in the opposite direction from said front portion, said rear portion having a downward slope intermediate from said wall portion and said front portion.

7. A threshold assembly as defined in Claim 6 in which said base includes a plurality of groove means formed therein below said central portion for receiving said adhesive means. 5

8. A threshold assembly as defined in Claim 8 in which said threshold is composed of a PVC vinyl material having resistance to ultraviolet radiation, and ozone and chemical degradation. 10

9. A threshold assembly as defined in Claim 6 in which said threshold is composed of a PVC vinyl material having resistance to ultraviolet radiation, and ozone and chemical degradation and in which said front portion provides support throughout the length of said door. 15

10. A threshold assembly for receiving the weatherstrip commonly applied to the bottom edge of garage doors comprising an elastomeric generally inverted V-shaped member with a generally flat base portion, the upper surface of said member having an apex near the approximate center thereof with downwardly inclined front and rear portions projecting radially from said apex, said front portion receiving said weatherstrip when the garage door is closed and said rear portion serving as a transitional ramp between said front portion and the garage floor, and a securing means disposed between said base portion and the garage floor. 20 25 30

11. A threshold assembly as defined in Claim 10 in which said securing means includes an adhesive for affixing said threshold to the slab.

12. A threshold assembly as defined in Claim 11 in which said base includes a plurality of groove means formed therein for receiving said adhesive. 35

13. A threshold assembly as defined in Claim 10 in which said threshold includes a steeply pitched wall portion extending between said inclined front portion and said apex receiving said door and weatherstrip for arresting bowing of said door and providing a dam against ingress of contaminants. 40 45

50

55

5

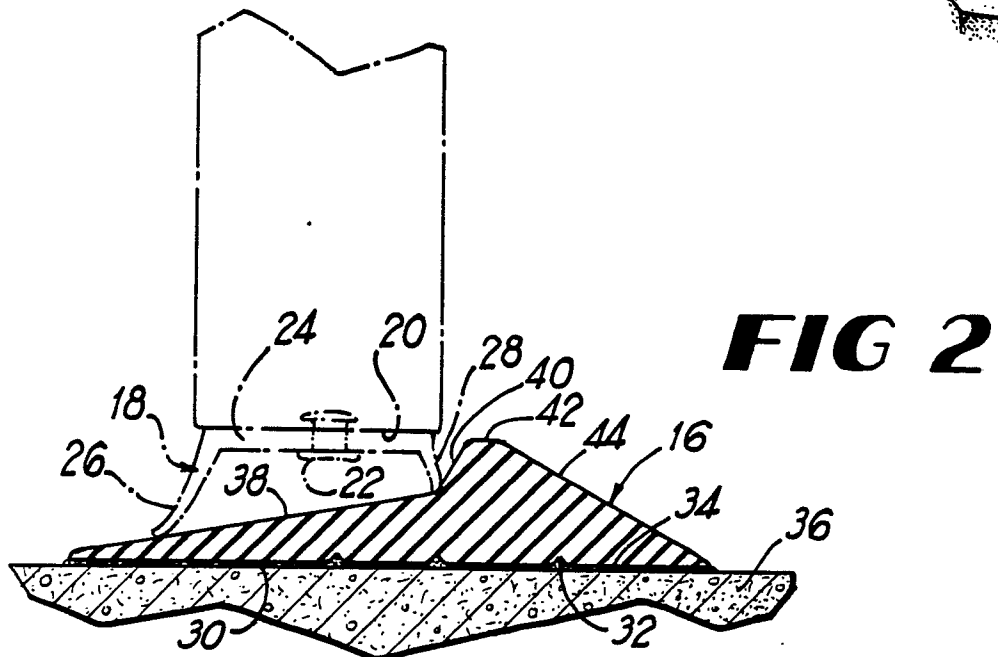
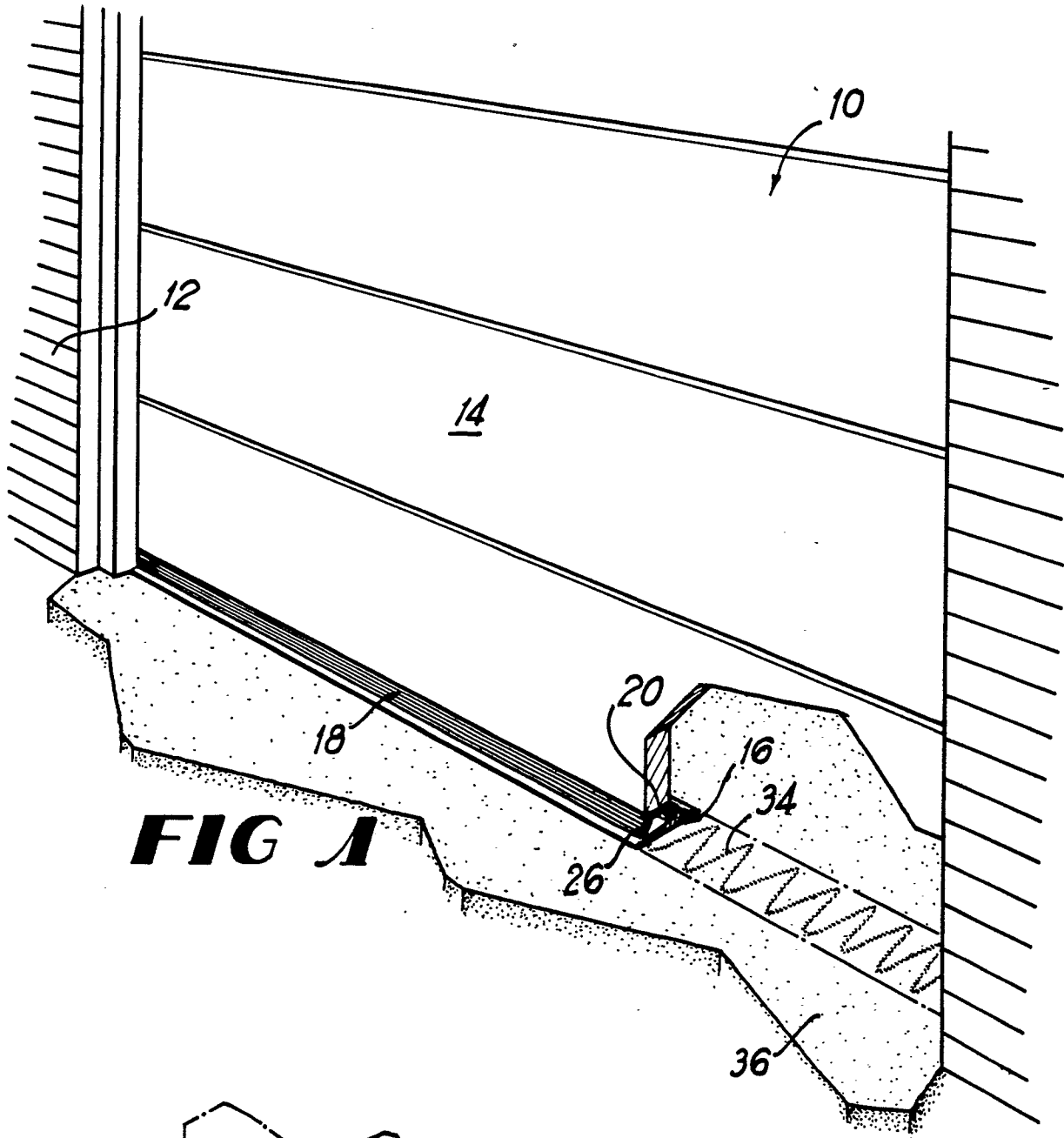



DOCUMENTS CONSIDERED TO BE RELEVANT			
Category	Citation of document with indication, where appropriate, of relevant passages	Relevant to claim	CLASSIFICATION OF THE APPLICATION (Int. Cl. 4)
A	US-A-2 572 154 (R. HOWARD) * Column 1, lines 26-55; column 2; column 3, lines 1-10; figures 1-3 * ---	1,2,6, 10,11	E 06 B 1/70 E 06 B 7/16 E 06 B 7/23
A	US-A-2 592 861 (W.A. CLOSE) * Column 2, lines 15-55; column 3, lines 1-33; figures 1-5 * ---	1,4,5,6 ,10,13	
A	US-A-4 463 523 (J.J. MAILAND) ---		
A	DE-A-3 245 831 (G + H MONTAGE GmbH) ---		
A	GB-A-2 017 795 (OVERHEAD DOOR CORP.) -----		
			TECHNICAL FIELDS SEARCHED (Int. Cl.4)
			E 06 B
The present search report has been drawn up for all claims			
Place of search THE HAGUE		Date of completion of the search 21-02-1989	Examiner: VIJVERMAN W.C.
CATEGORY OF CITED DOCUMENTS X : particularly relevant if taken alone Y : particularly relevant if combined with another document of the same category A : technological background O : non-written disclosure P : intermediate document		T : theory or principle underlying the invention E : earlier patent document, but published on, or after the filing date D : document cited in the application L : document cited for other reasons & : member of the same patent family, corresponding document	