

(19) World Intellectual Property Organization
International Bureau



(43) International Publication Date
19 March 2009 (19.03.2009)

PCT

(10) International Publication Number
WO 2009/033272 A1

(51) International Patent Classification:
B66B 23/24 (2006.01) *B32B 27/12* (2006.01)

(74) Agent: **BERESKIN & PARR**; 40 King Street West, Suite 4000, Toronto, Ontario M5H 3Y2 (CA).

(21) International Application Number:
PCT/CA2008/001599

(81) Designated States (unless otherwise indicated, for every kind of national protection available): AE, AG, AL, AM, AO, AT, AU, AZ, BA, BB, BG, BH, BR, BW, BY, BZ, CA, CH, CN, CO, CR, CU, CZ, DE, DK, DM, DO, DZ, EC, EE, EG, ES, FI, GB, GD, GE, GH, GM, GT, HN, HR, HU, ID, IL, IN, IS, JP, KE, KG, KM, KN, KP, KR, KZ, LA, LC, LK, LR, LS, LT, LU, LY, MA, MD, ME, MG, MK, MN, MW, MX, MY, MZ, NA, NG, NI, NO, NZ, OM, PG, PH, PL, PT, RO, RS, RU, SC, SD, SE, SG, SK, SL, SM, ST, SV, SY, TJ, TM, TN, TR, TT, TZ, UA, UG, US, UZ, VC, VN, ZA, ZM, ZW.

(22) International Filing Date:
10 September 2008 (10.09.2008)

(25) Filing Language: English

(26) Publication Language: English

(30) Priority Data:
60/971,163 10 September 2007 (10.09.2007) US

(71) Applicant (for all designated States except US): **EHC Canada, Inc.** [CA/CA]; 1287 Boundary Street, Oshawa, Ontario L1J 6Z7 (CA).

(84) Designated States (unless otherwise indicated, for every kind of regional protection available): ARIPO (BW, GH, GM, KE, LS, MW, MZ, NA, SD, SL, SZ, TZ, UG, ZM, ZW), Eurasian (AM, AZ, BY, KG, KZ, MD, RU, TJ, TM), European (AT, BE, BG, CH, CY, CZ, DE, DK, EE, ES, FI, FR, GB, GR, HR, HU, IE, IS, IT, LT, LU, LV, MC, MT, NL, NO, PL, PT, RO, SE, SI, SK, TR), OAPI (BF, BJ, CF, CG, CI, CM, GA, GN, GQ, GW, ML, MR, NE, SN, TD, TG).

(72) Inventors; and

(75) Inventors/Applicants (for US only): **HAIDER, Viqar** [CA/CA]; 7 Irenemount Crescent, Markham, Ontario L3S 3C7 (CA). **KENNY, Andrew Oliver** [CA/CA]; 242 Hounslow Avenue, Toronto, Ontario M2N 2B6 (CA). **CAUNCE, Alexander Stuart** [CA/CA]; 3510 Cornish Hollow Road, RR6, Cobourg, Ontario K9A 4J9 (CA).

Published:
— with international search report

(54) Title: MODIFIED HANDRAIL

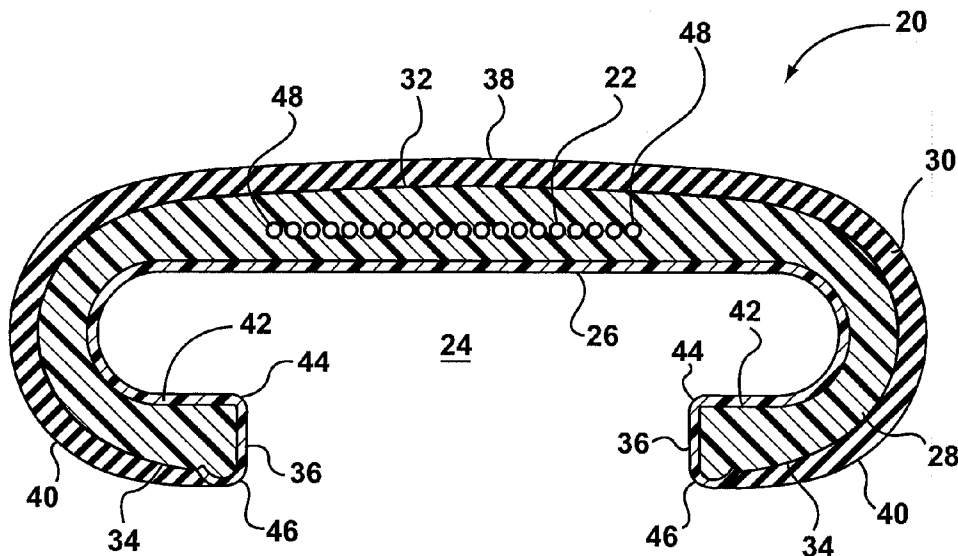

FIG. 2

(57) Abstract: Modified handrails for use in escalators, moving walkways and other transportation apparatus are provided. Handrail can include a configuration for a cable array as a stretch inhibitor that reduces cable buckling under severe flexing conditions. Handrail can also include a configuration for first and second thermoplastic layers in the lip portions that reduces strain and bending stresses and increases fatigue failure life under cyclic loading conditions. Handrail can also include, for the stretch inhibitor, the use of cables comprising large outer strands and small inner strands that enable penetration and adhesion within the first layer and can reduce incidence of fretting or corrosion.

WO 2009/033272 A1

TITLE: MODIFIED HANDRAIL**FIELD**

[0001] This specification relates generally to the field of handrails for escalators, moving walkways and similar transportation apparatus.

5 BACKGROUND

[0002] United States Patent No. 6,237,740 to Weatherall et al. discloses a moving handrail construction, for escalators, moving walkways and other transportation apparatus having a generally C-shaped cross-section and defining an internal generally T-shaped slot. The handrail is formed by
10 extrusion and comprises a first layer of thermoplastic material extending around the T-shaped slot. A second layer of thermoplastic material extends around the outside of the first layer and defines the exterior profile of the handrail. A slider layer lines the T-shaped slot and is bonded to the first layer. A stretch inhibitor extends within the first layer. The first layer is formed from
15 a harder thermoplastic than the second layer, and this has been found to give improved properties to the lip and improved drive characteristics on linear drives.

INTRODUCTION

[0003] A handrail is provided, the handrail having a generally C-shaped
20 cross-section and defining an internal generally T-shaped slot, the handrail comprising: thermoplastic material extending around the T-shaped slot defining semi-circular lip portions having generally opposing end walls, and defining the exterior profile of the handrail; a slider layer lining the T-shaped slot and bonded to the thermoplastic material; and a cable array for inhibiting
25 stretch, the cable array consisting of a plurality of longitudinal cables disposed along a central plane within the thermoplastic material, wherein outside cables of the cable array are offset inwardly in relation to the end walls of the lip portions.

[0004] Each of the plurality of cables can have a diameter of 0.5 to 2 mm. The cable array can have a width of 30 to 35 mm and a pitch of 1.5 to 2 mm.

[0005] The slider layer can include edge portions extending out of the T-shaped slot and around the end walls of the lip portions.

[0006] Another handrail is provided, the handrail having a generally C-shaped cross-section and defining an internal generally T-shaped slot, the handrail comprising: a first layer of thermoplastic material extending around the T-shaped slot defining inner walls of semi-circular lip portions; a second layer of thermoplastic material extending around the outside of the first layer and defining the exterior profile of the handrail and generally opposing end walls of the lip portions; a slider layer lining the T-shaped slot and bonded to the first layer; and a stretch inhibitor disposed along a plane within the first layer.

[0007] The first layer can taper in thickness around the lip portions and may not extend substantially below a bottom plane of the T-shaped slot. The first layer can terminate along the inner walls of the lip portions. The handrail can comprise an upper portion above the T-shaped slot and within the upper portion the first layer can be thicker than the second layer. The first layer can comprise at least 60% of the thickness of the handrail in the upper portion. The upper portion can have a thickness of approximately 10 mm and the first layer is at least 6 mm thick.

[0008] The first layer can be formed from a harder thermoplastic than the second layer. The first layer can have a hardness in the range 40 to 50 Shore 'D', the second layer can have a hardness in the range 70 to 85 Shore 'A' and the slider layer can have a modulus of 150 to 250 MPa.

[0009] The slider layer can include edge portions extending out of the T-shaped slot and around the end walls of the lip portions.

[0010] Another handrail is provided, the handrail having a generally C-shaped cross-section and defining an internal generally T-shaped slot, the

handrail comprising: a first layer of thermoplastic material extending around the T-shaped slot defining inner walls of semi-circular lip portions; a second layer of thermoplastic material extending around the outside of the first layer and defining the exterior profile of the handrail and generally opposing end walls of the lip portions; a slider layer lining the T-shaped slot and bonded to the first layer; and a cable array for inhibiting stretch, the cable array consisting of a plurality of longitudinal cables arranged along a central plane within the first layer, wherein outside cables in the cable array are offset inwardly in relation to the end walls of the lip portions.

10 [0011] Yet another handrail is provided, the handrail having a generally C-shaped cross-section and defining an internal generally T-shaped slot, the handrail comprising: a first layer of thermoplastic material extending around the T-shaped slot; a second layer of thermoplastic material extending around the outside of the first layer and defining the exterior profile of the handrail; a
15 slider layer lining the T-shaped slot and bonded to the first layer; and a cable array for inhibiting stretch, the cable array consisting of a plurality of longitudinal cables arranged along a central plane within the first layer, wherein each of the longitudinal cables including a plurality of relatively larger outer strands and a plurality of relatively small inner strands.

20 [0012] Each cable can have an outer diameter of about 1.15 mm. Each cable can consist of 6 outer stands and 3 inner strands. The outer strands can have a diameter of approximately 0.36 mm. The inner strands can have a diameter of approximately 0.2 mm. The cables can be formed of high tensile steel, and can be brass plated.

25 [0013] An escalator handrail, having a generally C-shaped cross-section and defining an internal generally T-shaped slot, comprises: a first layer of thermoplastic material extending around the T-shaped slot defining inner walls of semi-circular lip portions; a second layer of thermoplastic material extending around the outside of the first layer and defining the
30 exterior profile of the handrail and generally opposing end walls of the lip portions; a slider layer lining the T-shaped slot and bonded to the first layer;

and a cable array for inhibiting stretch, the cable array consisting of a plurality of longitudinal cables disposed along a central plane within the first layer, wherein outside cables of the cable array are offset inwardly in relation to the end walls of the lip portions, and wherein each of the longitudinal cables including a plurality of relatively larger outer strands and a plurality of relatively small inner strands.

[0014] These and other features of the applicant's teachings are set forth herein.

DRAWINGS

10 [0015] A detailed description of one or more embodiments is provided herein below by way of example only and with reference to the following drawings, in which:

[0016] FIG. 1 is a cross-sectional view of a known handrail;

[0017] FIG. 2 is a cross-sectional view of a modified handrail;

15 [0018] FIG. 3 is a cross-sectional view of another modified handrail;

[0019] FIG. 4 is a cross-sectional view of yet another modified handrail;

[0020] FIG. 5 is a cross-sectional view of a known handrail illustrating simulated stresses according to finite element analysis;

[0021] FIG. 6 is a pie chart illustrating the contribution of handrail components to the overall handrail stiffness in reverse bend conditions;

[0022] FIG. 7 is a graph illustrating the stiffness of handrails in reverse bend with and without the slider fabric;

[0023] FIGS. 8A and 8B are cross-sectional views of handrails having 45 and 33 mm cable arrays, respectively, and illustrate simulated stresses therein;

[0024] FIG. 9 is a cross-sectional view of a modified handrail illustrating simulated stresses therein;

[0025] FIG. 10 is a graph illustrating the results of dynamic handrail testing; and

[0026] FIGS. 11A and 11B illustrate cross-sections of a cable structure.

DESCRIPTION OF VARIOUS EMBODIMENTS

5 [0027] Various apparatuses or methods will be described below to provide an example of an embodiment of each claimed invention. No embodiment described below limits any claimed invention and any claimed invention may cover apparatuses or methods that are not described below. The claimed inventions are not limited to apparatuses or methods having all
10 of the features of any one apparatus or method described below or to features common to multiple or all of the apparatuses described below. One or more inventions may reside in a combination or sub-combination of the apparatus elements or method steps described below or in other parts of this document. It is possible that an apparatus or method described below is not an
15 embodiment of any claimed invention. The applicant(s), inventor(s) and/or owner(s) reserve all rights in any invention disclosed in an apparatus or method described below that is not claimed in this document and do not abandon, disclaim or dedicate to the public any such invention by its disclosure in this document.

20 [0028] An example of this known handrail construction is shown in FIG. 1. The handrail 10 may include a stretch inhibitor 12, which in this case is illustrated as an array of longitudinal steel cables but can instead comprise steel tape, KEVLAR™ or other suitable tensile elements. As shown, the stretch inhibitor 12 can be supplied embedded in a first or inner layer 14, and
25 can be adhered thereto with a suitable adhesive. The inner layer 14 can be formed of a relatively hard thermoplastic and an outer layer 16 can be formed of a relatively soft thermoplastic. The layers 14, 16 bond directly to one another at an interface to form a continuous thermoplastic body. The T-shaped slot is lined by slider fabric 18. The slider fabric can be an
30 appropriate cotton or synthetic material, with a suitable texture.

- 6 -

[0029] Applicant's teachings relate to modified handrail configurations that take into account dynamics and interaction of different materials and layers during flex conditions.

[0030] Referring to FIG. 2, an example of a modified handrail construction is generally designated by the reference 20. The handrail 20 includes a cable array 22 as a stretch inhibitor, discussed more fully below. Surrounding the T-slot 24, the handrail includes a slider 26 bonded to at least the first or inner layer 28. The slider 26 may include end portions wrapped around downwardly facing ribs of the first layer, as illustrated. The inner layer 28 comprises an upper portion or web 32 of generally uniform thickness, which continues into two semi-circular lip portions 34. Correspondingly, the outer layer 30 also comprises an upper portion or web 38 of generally uniform thickness, which continues into two semi-circular lip portions 40. The lip portions 34 include inner walls 42 and the lip portions 34 terminate at generally opposing end walls 36. Each end wall includes an inside edge 44 and an outside edge 46.

[0031] The two layers 28, 30 can have different characteristics or hardnesses. In some examples, the outer layer 30 is a softer grade of thermoplastic than the inner layer 28. Example properties of the two layers are given in the Table 1.

TABLE 1

	Inner Layer 28	Outer Layer 30
Hardness	40-50 Shore 'D'	70-85 Shore 'A'
100% tensile modulus	11 MPa	5.5 MPa
Flexural modulus	63 MPa	28 MPa
Shear modulus	6-8 MN/m ²	4-5 MN/m ²

[0032] The inner layer 28 can be harder and generally stiffer, and can serve to retain the lip dimension, i.e. the spacing across the bottom of the T-

shaped slot 24. The inner layer 28 can also serve to protect the stretch inhibitor 22, in this case steel cables provided in a cable array, and the bond between these cables and the thermoplastic material of inner layer 28 can be provided by a layer of adhesive. Each cable can comprise a number of
5 individual steel wires or strands and overall can have a diameter in the range 0.5 to 2 mm, for example.

[0033] It should be understood that handrails typically do not have a flat top surface, but instead there is usually a minor convex curve. Many commercially available transportation apparatus, especially escalators, utilize
10 a reverse bend drive to propel the endless handrail in a particular direction. Under tight reverse bend drive conditions (e.g., with a radius of 275 mm or less) the outer cables within the cable array can be forced out of the neutral axis when in a reverse bend because of the lip portions, or the curved handrail top surface, or both, while the middle cables remain generally in the
15 same plane. With the outer cables pushed away from the neutral flexing plane, buckling can occur. This buckling can cause breakage even after only a few flexes, depending upon the reverse bend radius and the slider modulus.

[0034] In some examples, the stretch inhibitor 22 can be disposed within a central plane within the first layer 28, and end cables of the cable
20 array are offset inwardly in relation to the end walls 36 of the lip portions 34. In other words, the handrail 20 has a relatively narrow cable array 22. This feature should be clear to the reader by comparing FIG. 1 to FIG. 2. In operation, having the end cables 48 spaced away from the regions of lip stress can affect the outer cables 48 ability to retain a neutral plane during
25 flexing, lessening chance of outer cables buckling, as further discussed below.

[0035] Referring to FIG. 3, another example of a modified handrail construction is generally designated by the reference 60. For simplicity, like components are given the same reference numeral as in FIG. 2, and the
30 description of the components is not repeated.

[0036] In apparatus 60, the inner layer 28 extends around the T-shaped slot 24 defining inner walls of semi-circular lip portions 62. The inner layer 28a tapers around the lip portions 62 and terminates along the inner walls 64 of the lip portions 62. Correspondingly, the outer layer 30 has semi-circular end portions 68 having increasing thickness towards the end walls 66. This compensates for the tapering of the inner layer 28a. As illustrated in FIG. 3, the inner layer 28a preferably does not extend below a bottom plane L of the T-shaped slot 24, the bottom plane L being below the slider fabric 14 portions defining the bottom of the upper part of the T-shaped slot 24.

10 [0037] It should be understood that this configuration of the inner layer 28a, which can be 25% stiffer than second layer 30, for example, and having a higher modulus than the material of the second layer 30, moves the inner layer 28a out of the strained location to a relatively lower strained location when under the load of a reverse bend drive. This change can result in a lower overall bending modulus and in a slightly lower or non-existing change in the lip strength. This configuration can also increase the fatigue failure life under cyclic loading conditions.

[0038] Referring to FIG. 4, another example of a modified handrail construction is generally designated by the reference 80. Handrail 80 is essentially a hybrid combination of handrails 20, 60. In other words, the handrail 80 features (i) a relatively narrow cable array and (ii) a tapered inner layer that does not extend below a bottom plane of the T-shaped slot.

[0039] Finite element analysis (FEA) and physical testing was conducted to examine the behavior of various handrails, particularly under severe flexing conditions. One test is a three point reverse bend deformation of 1 m of handrail (80 mm wide with a 45 mm wide cable array comprising 20 cables) supported by two supports spaced apart by 615 mm; a 50 mm diameter round piece is used to deform the handrail 100 mm at a located approximately equidistant from the cylindrical supports.

30 [0040] An FEA model was used to simulate a three point reverse bend in accordance with the parameters mentioned above. FIG. 5 is a cross

sectional view of a conventional handrail showing the Von Mises stress under deformation. As shown therein, under tensile and bending load the cable array experiences the highest bending stress (indicated by the darker shading), followed by the slider and then the thermoplastic layers.

5 [0041] FEA modeling has lead to the discovery that the slider layer may be the single largest contributing factor in the modulus of a handrail in reverse bend stress scenarios. For this reason, it can be beneficial to pretreat the slider layer prior to forming so as to minimize tension. An example of a method and apparatus for slider layer pretreatment is disclosed in the
10 Applicant's United States Provisional Application No. 60/971,156, filed on 10 September 2007 and entitled "METHOD AND APPARATUS FOR PRETREATMENT OF A SLIDER LAYER FOR EXTRUDED COMPOSITE HANDRAILS", and the corresponding PCT Application filed on 10 September 2008, the entire contents of both are incorporated herein by reference.

15 [0042] FIG. 6 is a representation of the results obtained from a FEA model with no handrail tension. This shows the contribution of various components of the handrail in regards to the overall handrail stiffness. INSTRON™ testing of handrails, with and without sliders, in accordance with the parameters mentioned above, confirmed that the slider can be the main
20 contributor in handrail's stiffness (FIG. 7). In this test, a regular handrail was subjected to 100 mm deformation (a complete cycle) with and without the slider. The graph illustrates that a handrail without the slider is significantly less stiff in reverse bending.

[0043] Given this discovery, it is preferable to be use a lower modulus
25 slider. A lower modulus slider reduces handrail stiffness in reverse bending and also improves the overall Von Mises stress in the handrail, thus improving product fatigue life. The slider layer undergoes tensile loading during handrail bending, so a modulus value should be chosen that provides sufficient structural strength with a low overall handrail bend modulus. FEA studies
30 showed that slider layer having a modulus of around 150-250 MPa is suitable for handrail according to the configuration mentioned above, noting that the

maximum strain on the slider layer during flexing in most escalator units is up to 6%.

[0044] FEA models were further developed to understand the handrail composite behavior mostly in reverse bending, also with the help of INSTRON™ tests validation method. These analyses showed that although the steel cables in current handrail configurations may contribute 19% in reverse bend stiffness, this could increase depending on particular deformation conditions, such as reverse bend radius and the amount of slider stretch. At higher deformations, the lips start to displace the end cables and force them to move out of the plane of rest of the cables. This results in higher ultimate bending modulus, and under severe bending causes the outermost cables to buckle. Steel cables tend to be relatively hard, having a hardness of up to 67 Rockwell C-Scale, for example, and therefore buckling can occur relatively easily. This phenomenon is more pronounced under certain conditions, such as when the handrail is in reverse bending without the outer surface being supported by a pulley or drive roller, which is possible if the handrail is running loose on the escalator. Under this condition, if the handrail outer surface is not supported, the lip portions can exert excessive stresses on outer cables and can cause them to buckle very quickly.

[0045] To avoid the outermost cable buckling phenomenon under severe flexing conditions causing (a) the potential cable failures and (b) higher bending stiffness, FEA studies were conducted to review the particular solution proposed to an aspect of the present invention, namely, narrowing the cable array such that the outer cables are offset inwardly in relation to the lip portions. This can be achieved by reducing the cable pitch within the cable array in the composite structure, which maintaining the same number of cables.

[0046] As an example, a known handrail may comprise a cable array having 20 longitudinal cables with a cable pitch of 2.3 mm, which gives a 45 mm wide cable array. Models were developed with 1.65 mm pitch which gives 33 mm wide cable array. The studies showed a significant

improvement in both cable buckling behavior and reduction in overall handrail bending stiffness with a lower pitch distance. Specifically, it was found that around 15% less force was required for a 33 mm cable array handrail than for a 45 mm wide cable array handrail to achieve a reverse bend radius of 250 mm, under identical conditions. These results were also validated by INSTRON™ testing and the handrail with a narrower cable array width exhibited a lower reverse bend stiffness.

[0047] The higher Von Mises and the outer cable movement could also be seen in sections of FEA models when handrails with both a 45 mm wide cable array and a 33 mm wide cable array were deformed under similar conditions. As shown in FIGS. 8A and 8B, the outer cables in the 45 mm cable array (FIG. 8A) have a higher bending stress (darker shading) than the outer cables in the 33 mm cable array (FIG. 8B). Moving outer cables away from the lip stress line significantly affects the outer cables ability to retain their original plane during flexing and therefore lessening the chances of outer cables buckling.

[0048] FEA studies were also conducted to examine the location and ratios of the two layers of thermoplastic material under severe flexing conditions. As discussed above, conventional handrail designs where the inner layer extends or reaches to the end wall of the lip portion may result in good lip strength but leads to higher strain and overall higher bending stresses in the lip portions of the handrail. As a particular aspect of the present invention, this is improved by reconfiguring the inner layer so that it tapers and terminates along the inner wall of the lip portion, not below a bottom plane of the T-shaped slot.

[0049] With reference to FIG. 9, the modifications to the cross sectional configuration of the handrail design can be seen in the stress diagram (no slider is shown). This hybrid model depicts a conventional handrail design on the left and a modified handrail on the right, the modified handrail including a narrowed cable array (33 mm in width) and the modified first and second layer profile. Illustrated therein is a higher distribution of Von Mises stress in the lip

portion of the conventional handrail design, which is shown to be much darker than the same region in the modified lip portion.

[0050] In addition, it should be understood that another feature that may be important for the performance of the handrail is the radii of the lip portions. The inventors have discovered, through FEA analysis, that a
5 smaller lip portion radii may correlate with an increase in the stiffness of the handrail during bending and may also create high stresses. Because of this, it is preferable that both the inside and outside radii of the lip portions be increased rather than decreased when determining handrail design. For
10 example, for an 80 mm wide handrail a lip portion with an inner radius of about 2.0 mm and an outer radius of about 2.0 to 2.25 mm may be suitable.

[0051] With reference to FIG. 10, dynamic handrail testing was performed on a escalator drive mechanism test rig, including a 267 mm radius reverse bend, which was run at high speeds (approximately 255 m/min).
15 These tests were performed to validate modifications to the handrail design. Test handrails A and B represent conventional designs (80 mm wide with a 45 mm wide cable array comprising 20 cables; the inner layer extending to end walls of the lip portions). Test handrails C and D represent modified designs (80 mm wide with a 33 mm wide cable array comprising 20 cables; inner layer
20 tapers and terminates along inner walls of the lip portions, not below a bottom plane of the T-shaped slot; slider layer with modulus 200 to 250 MPa).

[0052] As shown, the modified designs C and D exhibited superior performance, with the handrails capable of achieving more than two million cycles minimum without failure.

[0053] An example of a typical cable cross sectional configuration is shown in FIG. 11A. Such a conventional steel cable, comprised of small individual strands, e.g., in a "7+4" pattern, may suffer from poor penetration of rubber/thermoplastic/adhesive. As a general problem, fretting and/or corrosion may occur in a steel cable if individual wires are not protected and
25 shielded from one another by rubber, thermoplastic, adhesive, etc. If fretting
30

or corrosion occurs, the handrail may shrink which is undesirable and can lead to failure of the handrail.

[0054] A stretch inhibitor with a particular cross-sectional configuration is provided as illustrated in FIG. 11B. As shown therein, the "3+6" pattern
5 comprises large outer strands and small inner strands of steel cable. This configuration can allow for good penetration of rubber, thermoplastic, adhesive, etc. For example, given the handrail construction described above, the first layer of thermoplastic material can be able to substantially penetrate and protect the cables, and the high adhesion results in a product that is
10 resistant to length change. This penetration can be achieved by extruding the thermoplastic and steel cables together under suitable pressure conditions that promote penetration of the thermoplastic into the interstices between the individual strands. An example of a method and apparatus for extrusion of thermoplastic handrail is disclosed in the Applicant's United States Provisional
15 Application No. 60/971,152, filed on 10 September 2007 and entitled "METHOD AND APPARATUS FOR EXTRUSION OF THERMOPLASTIC HANDRAIL", and the corresponding PCT Application filed on 10 September 2008, the entire contents of both are incorporated herein by reference.

[0055] Table 2 below provides example specifications for a suitable
20 stretch inhibitor cable with a cross-section as illustrated in FIG. 11B. Suitable cable in line with these example specifications can be obtained from Bekaert SA, of Kortrijk, Belgium.

TABLE 2

Type	-	High tensile steel cord, brass plated
Construction	mm	3X0.20 +/- 0.01 + 6X0.36 +/- 0.01
Twist (lay length)	1 turn per	9.5 +/- 0.5 mm Z + 18.0 +/- 0.9 mm S
Linear density	g/m (lb/ft)	5.59 +/- 0.28 (0.00376 +/- 0.00019)
Diameter	mm (in)	1.15 +/- 0.06 (0.045 +/- 0.0024)
Strength – minimum individual	N (lb)	1870 (420)
Strength – aim	N (lb)	1990 (447)

[0056] It will be appreciated by those skilled in the art that other variations of the one or more embodiments described herein are possible and may be practised without departing from the scope of the present invention as claimed herein.

- 15 -

CLAIMS

We claim:

1. A handrail having a generally C-shaped cross-section and defining an internal generally T-shaped slot, the handrail comprising:
 - a) thermoplastic material extending around the T-shaped slot defining semi-circular lip portions having generally opposing end walls, and defining the exterior profile of the handrail;
 - b) a slider layer lining the T-shaped slot and bonded to the thermoplastic material; and
 - c) a cable array for inhibiting stretch, the cable array consisting of a plurality of longitudinal cables disposed along a central plane within the thermoplastic material, wherein outside cables of the cable array are offset inwardly in relation to the end walls of the lip portions.
2. The handrail of claim 1 wherein each of the plurality of cables has a diameter of 0.5 to 2 mm.
3. The handrail of claims 1 or 2 wherein the cable array has a width of 30 to 35 mm and a pitch of 1.5 to 2 mm.
4. The handrail of any one of claims 1 to 3 wherein the slider layer includes edge portions extending out of the T-shaped slot and around the end walls of the lip portions.
5. A handrail having a generally C-shaped cross-section and defining an internal generally T-shaped slot, the handrail comprising:
 - a) a first layer of thermoplastic material extending around the T-shaped slot defining inner walls of semi-circular lip portions;
 - b) a second layer of thermoplastic material extending around the outside of the first layer and defining the exterior profile of the handrail and generally opposing end walls of the lip portions;
 - c) a slider layer lining the T-shaped slot and bonded to the first layer; and

- 16 -

d) a stretch inhibitor disposed along a plane within the first layer.

6. The handrail of claim 5 wherein the first layer tapers in thickness around the lip portions and does not extend substantially below a bottom plane of the T-shaped slot.

7. The handrail of claims 5 or 6 wherein the first layer terminates along the inner walls of the lip portions.

8. The handrail of any one of claims 5 to 7 wherein the handrail comprises an upper portion above the T-shaped slot and within the upper portion the first layer is thicker than the second layer.

9. The handrail of claim 8 wherein the first layer comprises at least 60% of the thickness of the handrail in the upper portion.

10. The handrail of claims 8 or 9 wherein the upper portion has a thickness of approximately 10 mm and the first layer is at least 6 mm thick.

11. The handrail of any one of claims 5 to 10 wherein the first layer is formed from a harder thermoplastic than the second layer.

12. The handrail of any one of claims 5 to 11 wherein the first layer has a hardness in the range 40 to 50 Shore 'D', the second layer has a hardness in the range 70 to 85 Shore 'A' and the slider layer has a modulus of 150 to 250 MPa.

13. The handrail of any one of claims 5 to 12 wherein the slider layer includes edge portions extending out of the T-shaped slot and around the end walls of the lip portions.

14. A handrail having a generally C-shaped cross-section and defining an internal generally T-shaped slot, the handrail comprising:

a) a first layer of thermoplastic material extending around the T-shaped slot defining inner walls of semi-circular lip portions;

- 17 -

b) a second layer of thermoplastic material extending around the outside of the first layer and defining the exterior profile of the handrail and generally opposing end walls of the lip portions;

c) a slider layer lining the T-shaped slot and bonded to the first layer; and

d) a cable array for inhibiting stretch, the cable array consisting of a plurality of longitudinal cables arranged along a central plane within the first layer, wherein outside cables in the cable array are offset inwardly in relation to the end walls of the lip portions.

15. A handrail having a generally C-shaped cross-section and defining an internal generally T-shaped slot, the handrail comprising:

a) a first layer of thermoplastic material extending around the T-shaped slot;

b) a second layer of thermoplastic material extending around the outside of the first layer and defining the exterior profile of the handrail;

c) a slider layer lining the T-shaped slot and bonded to the first layer; and

d) a cable array for inhibiting stretch, the cable array consisting of a plurality of longitudinal cables arranged along a central plane within the first layer, wherein each of the longitudinal cables including a plurality of relatively larger outer strands and a plurality of relatively small inner strands.

16. The handrail of claim 15 wherein each cable has an outer diameter of about 1.15 mm.

17. The handrail of claims 15 or 16 wherein each cable consists of 6 outer strands and 3 inner strands.

18. The handrail of claim 17 wherein the outer strands have a diameter of approximately 0.36 mm.

- 18 -

19. The handrail of claims 17 or 18 wherein the inner strands have a diameter of approximately 0.2 mm.

20. The handrail of any one of claims 15 to 19 wherein the cables are formed of high tensile steel.

21. The handrail of any one of claims 15 to 20 wherein the cables are brass plated.

22. A handrail having a generally C-shaped cross-section and defining an internal generally T-shaped slot, the handrail comprising:

a) a first layer of thermoplastic material extending around the T-shaped slot defining inner walls of semi-circular lip portions;

b) a second layer of thermoplastic material extending around the outside of the first layer and defining the exterior profile of the handrail and generally opposing end walls of the lip portions;

c) a slider layer lining the T-shaped slot and bonded to the first layer; and

d) a cable array for inhibiting stretch, the cable array consisting of a plurality of longitudinal cables disposed along a central plane within the first layer, wherein outside cables of the cable array are offset inwardly in relation to the end walls of the lip portions, and wherein each of the longitudinal cables including a plurality of relatively larger outer strands and a plurality of relatively small inner strands.

23. A handrail substantially as hereinbefore described with reference to or as shown in the accompanying drawings.

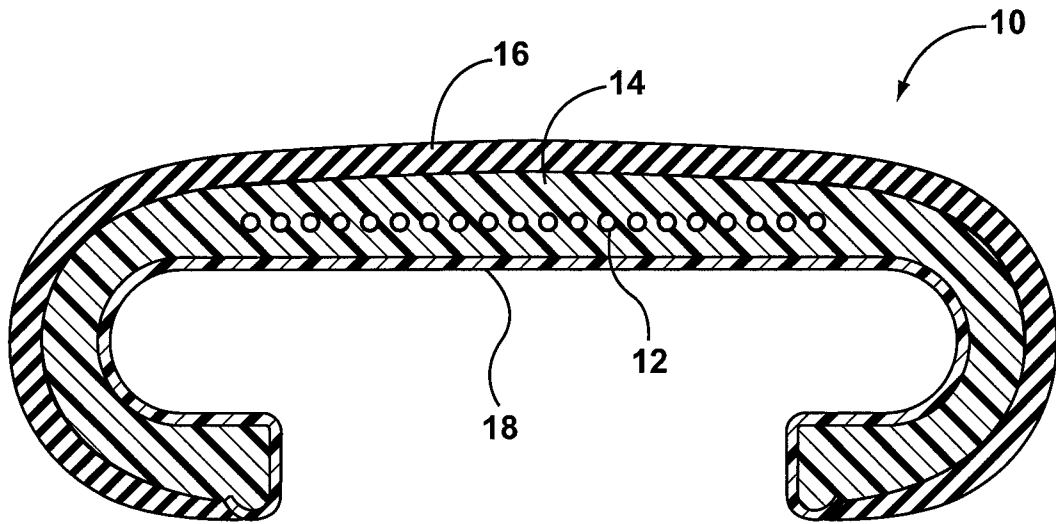

FIG. 1 (Prior Art)

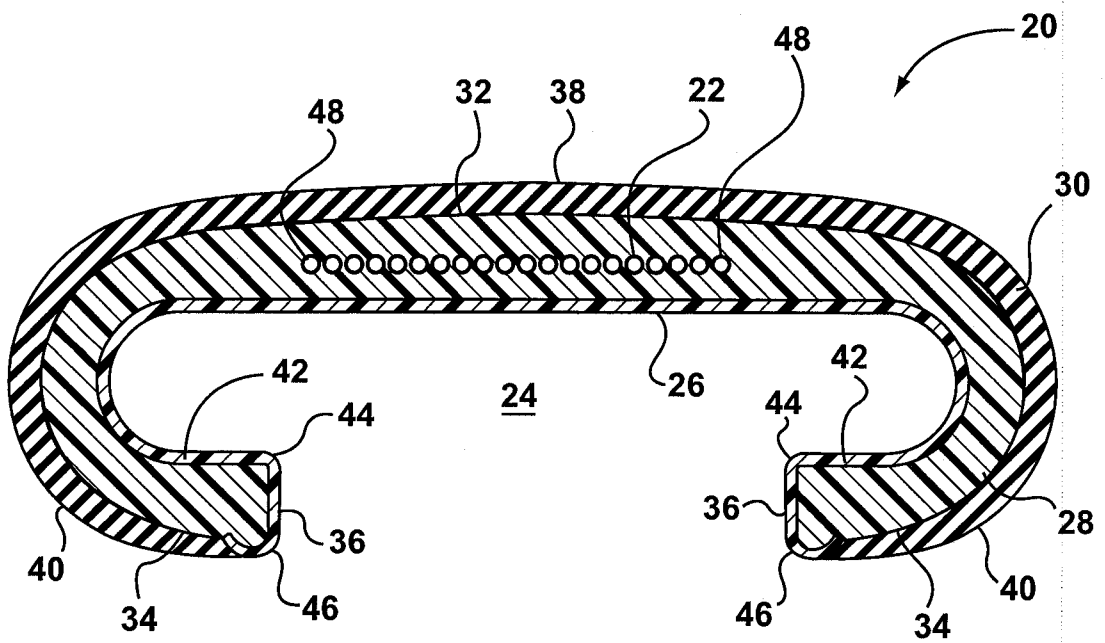

FIG. 2

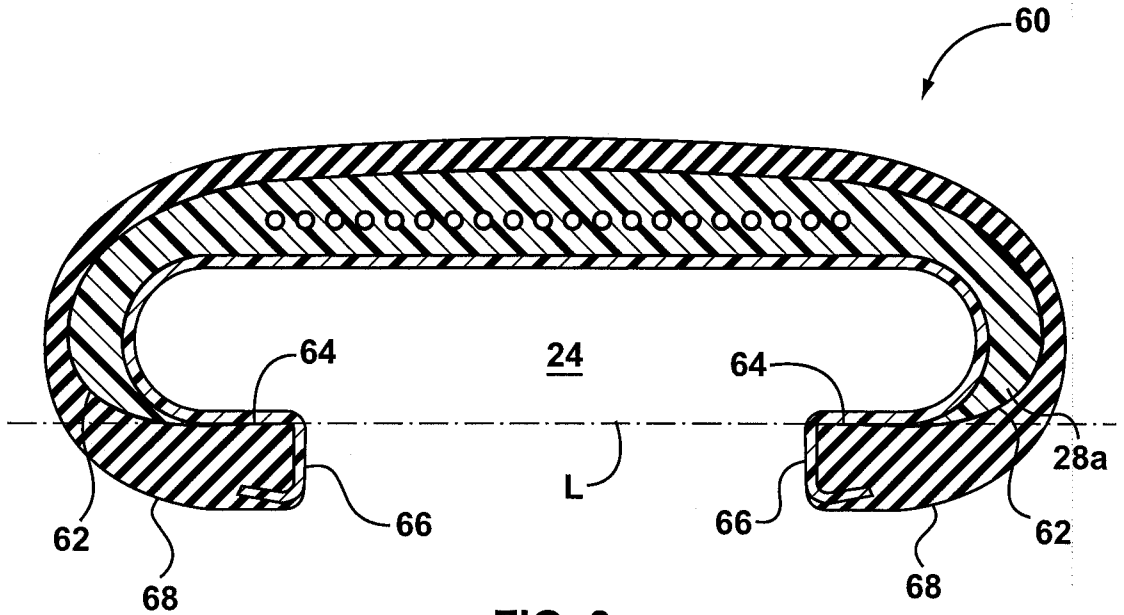

FIG. 3

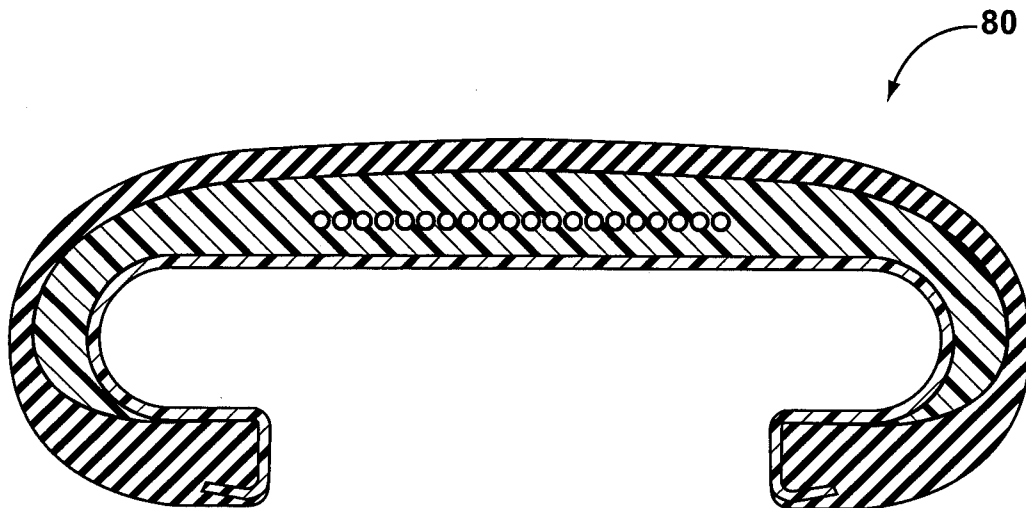

FIG. 4

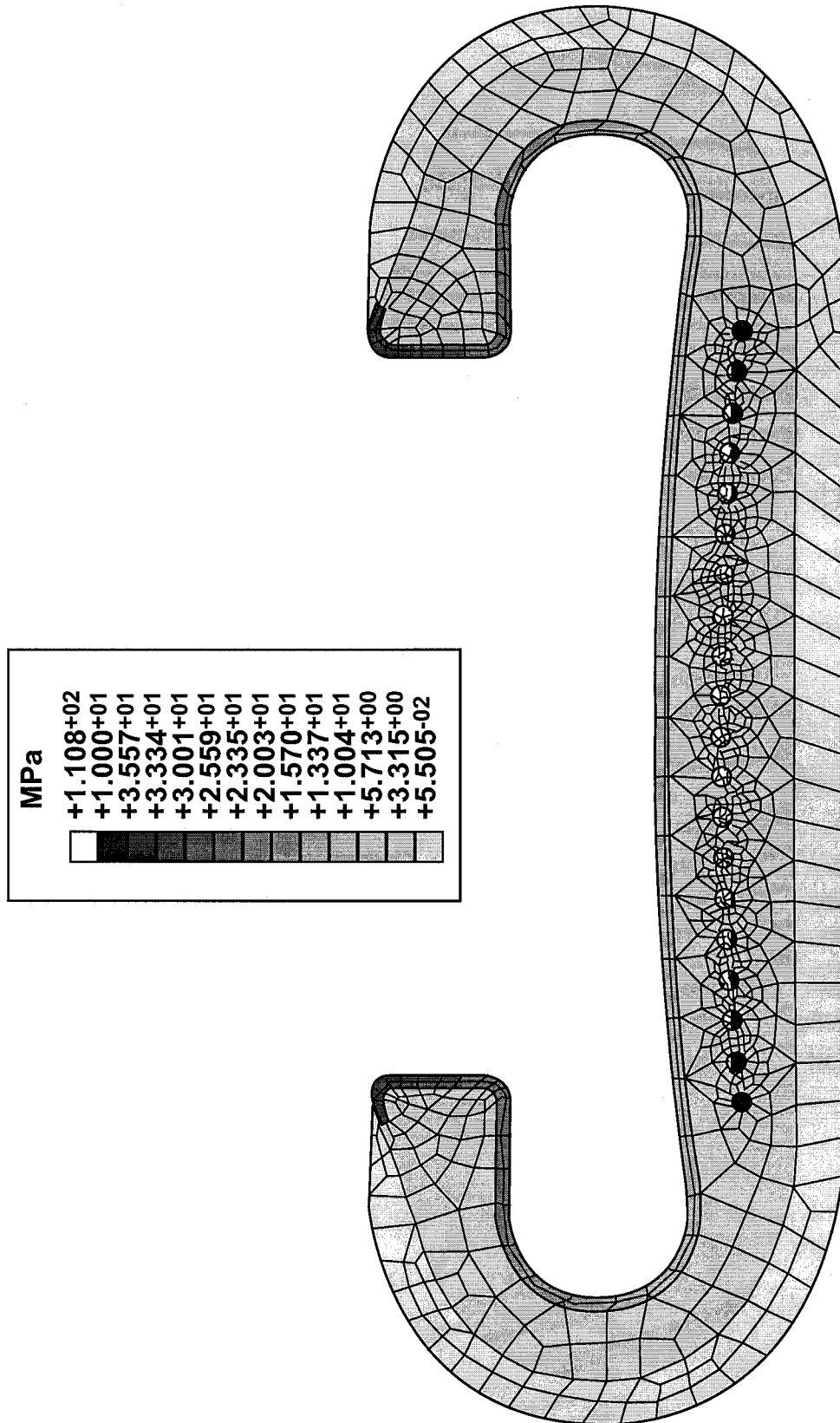

FIG. 5

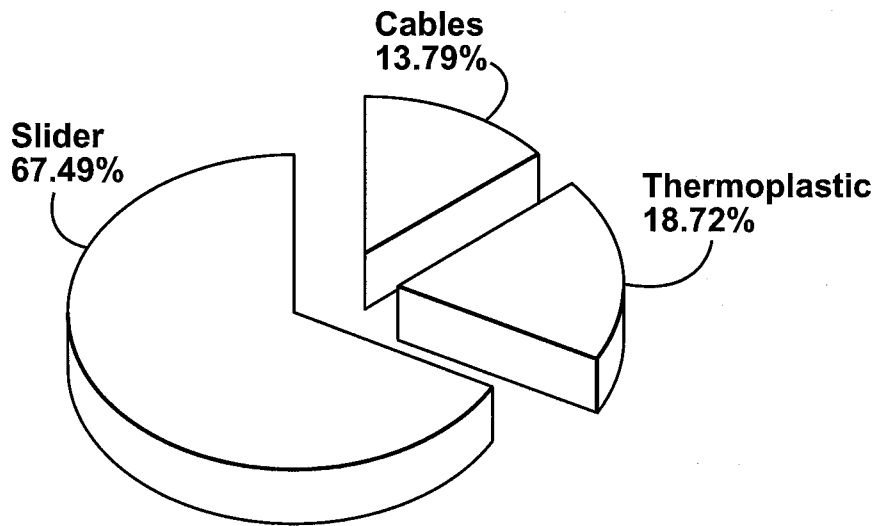
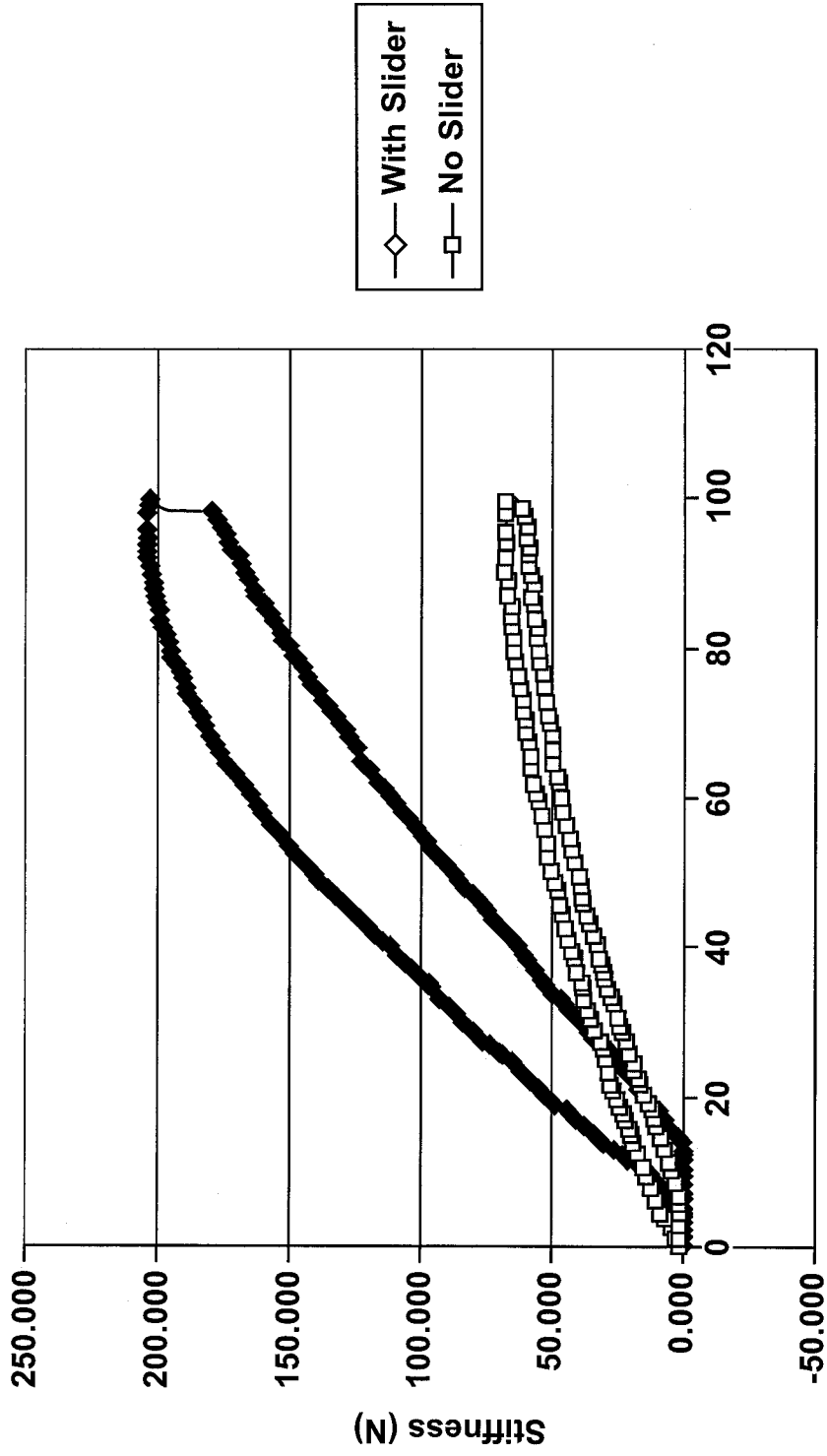

FIG. 6



Deformation (mm)

FIG. 7

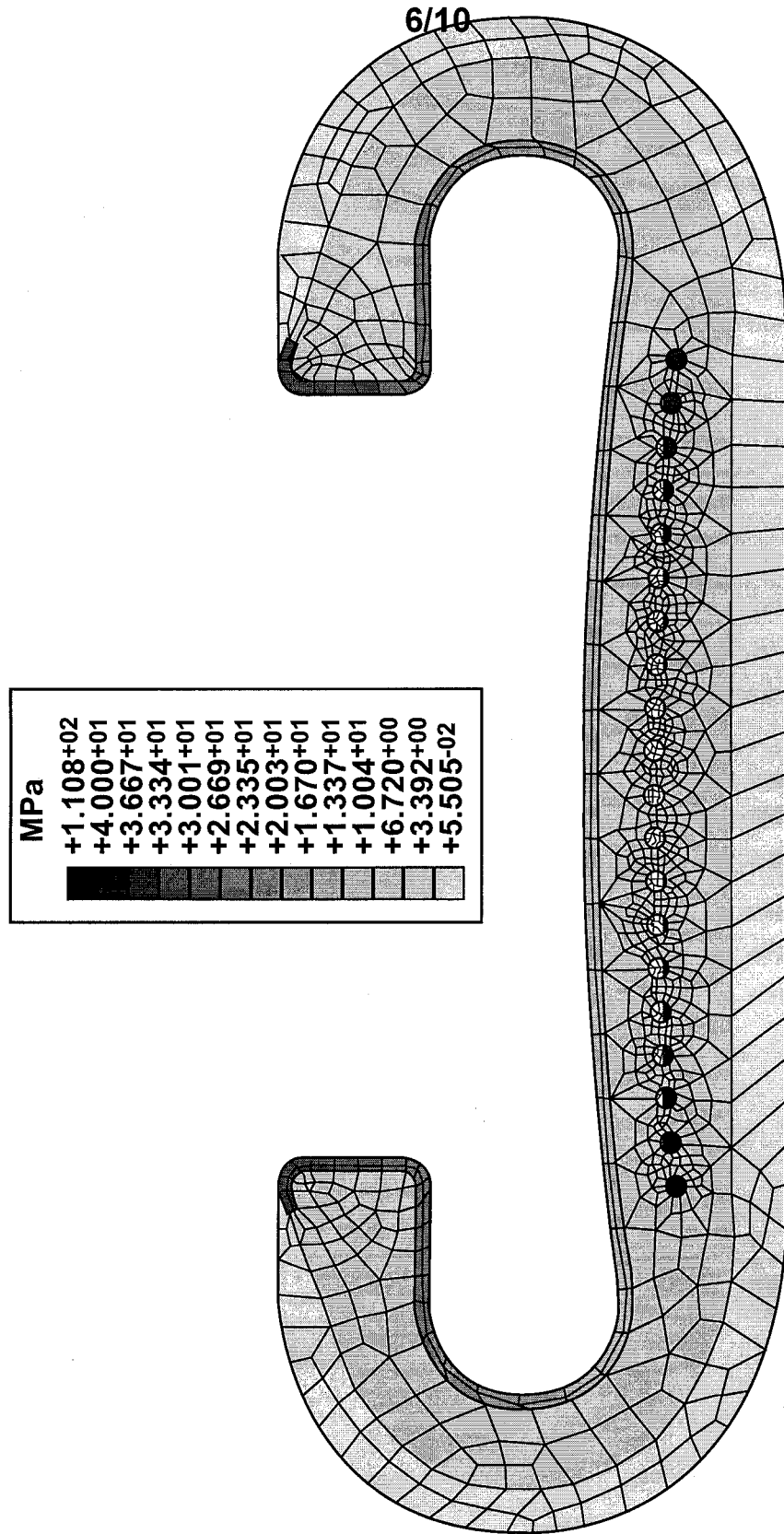

FIG. 8A

7/10

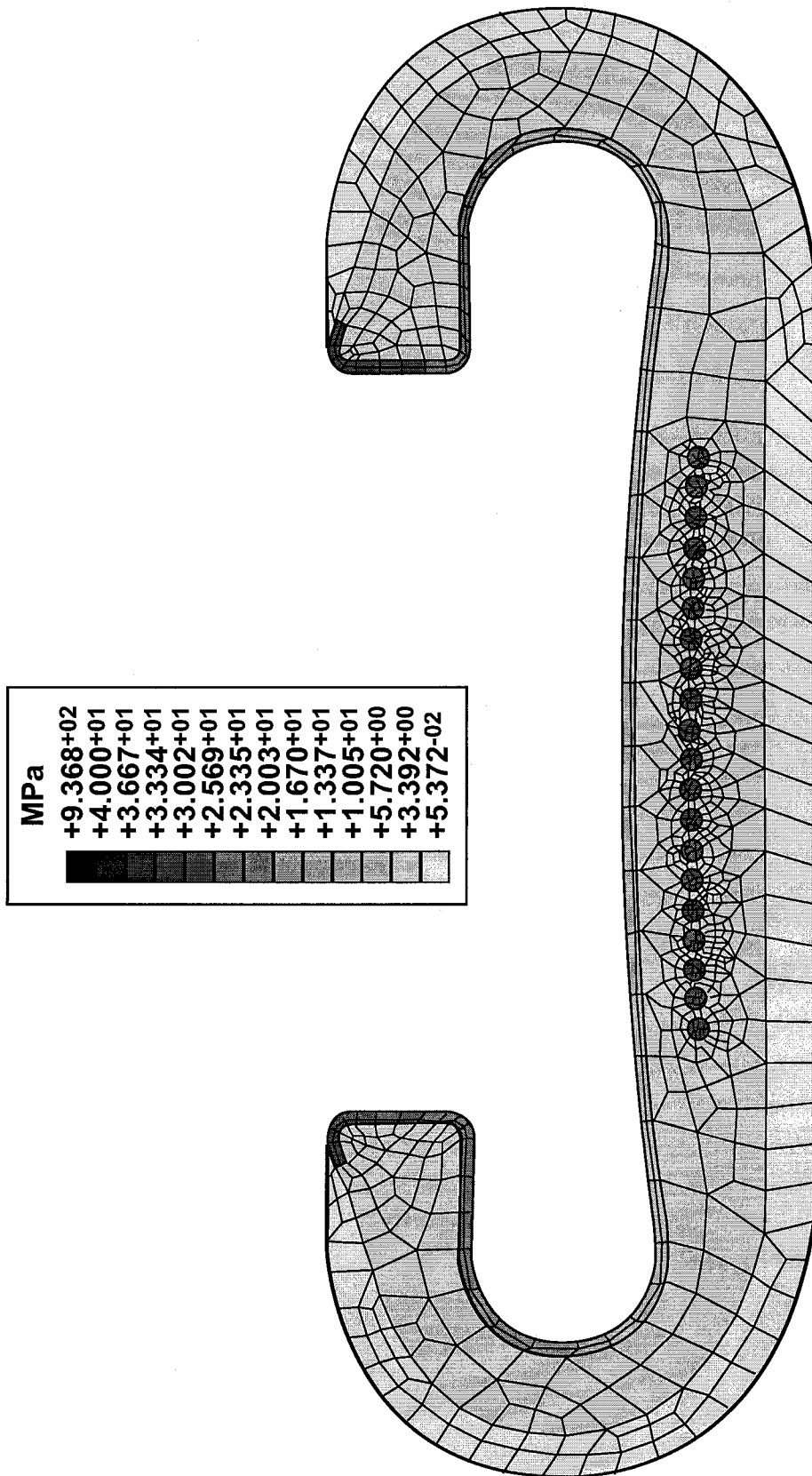

FIG. 8b

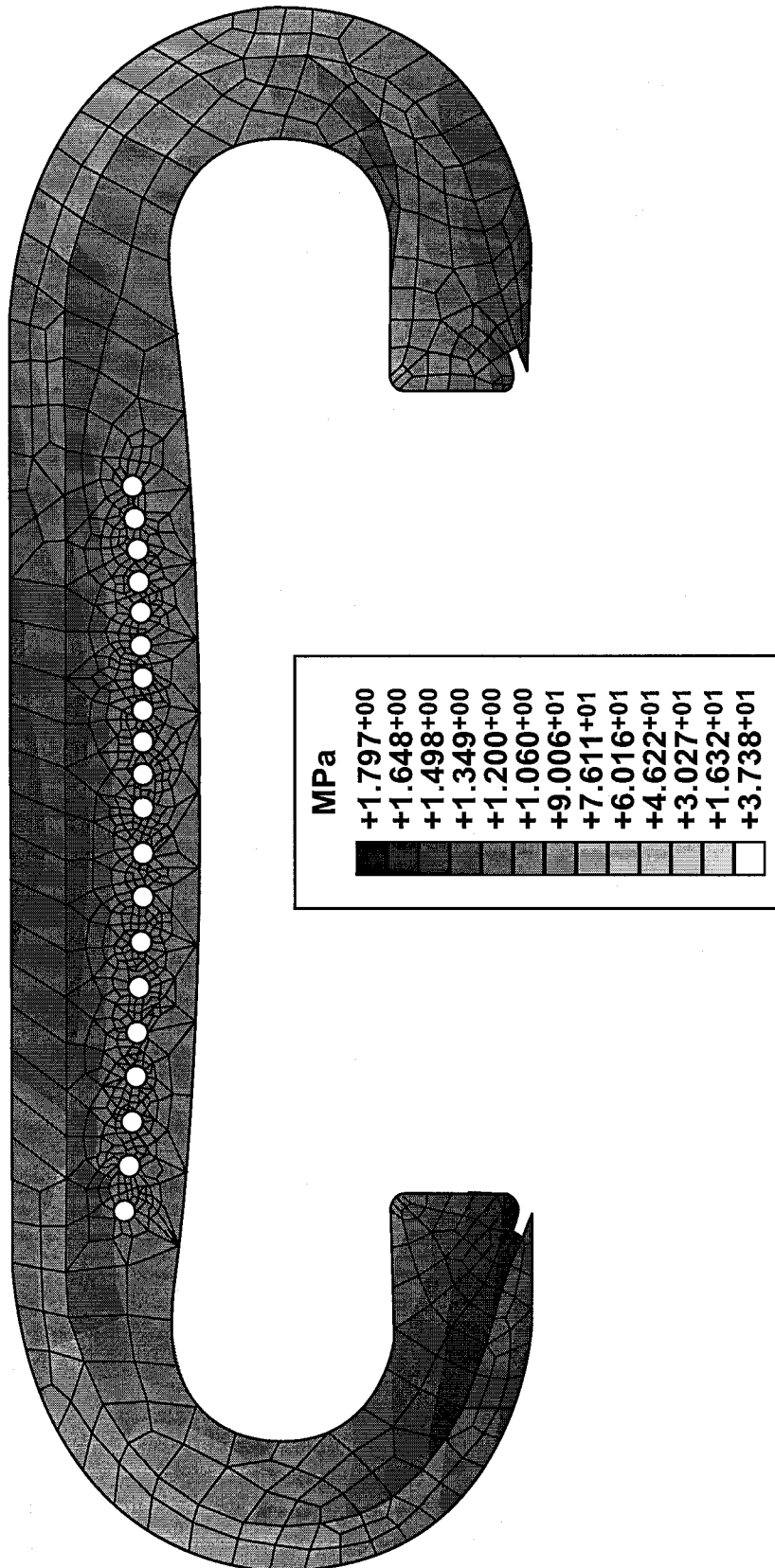

FIG. 9

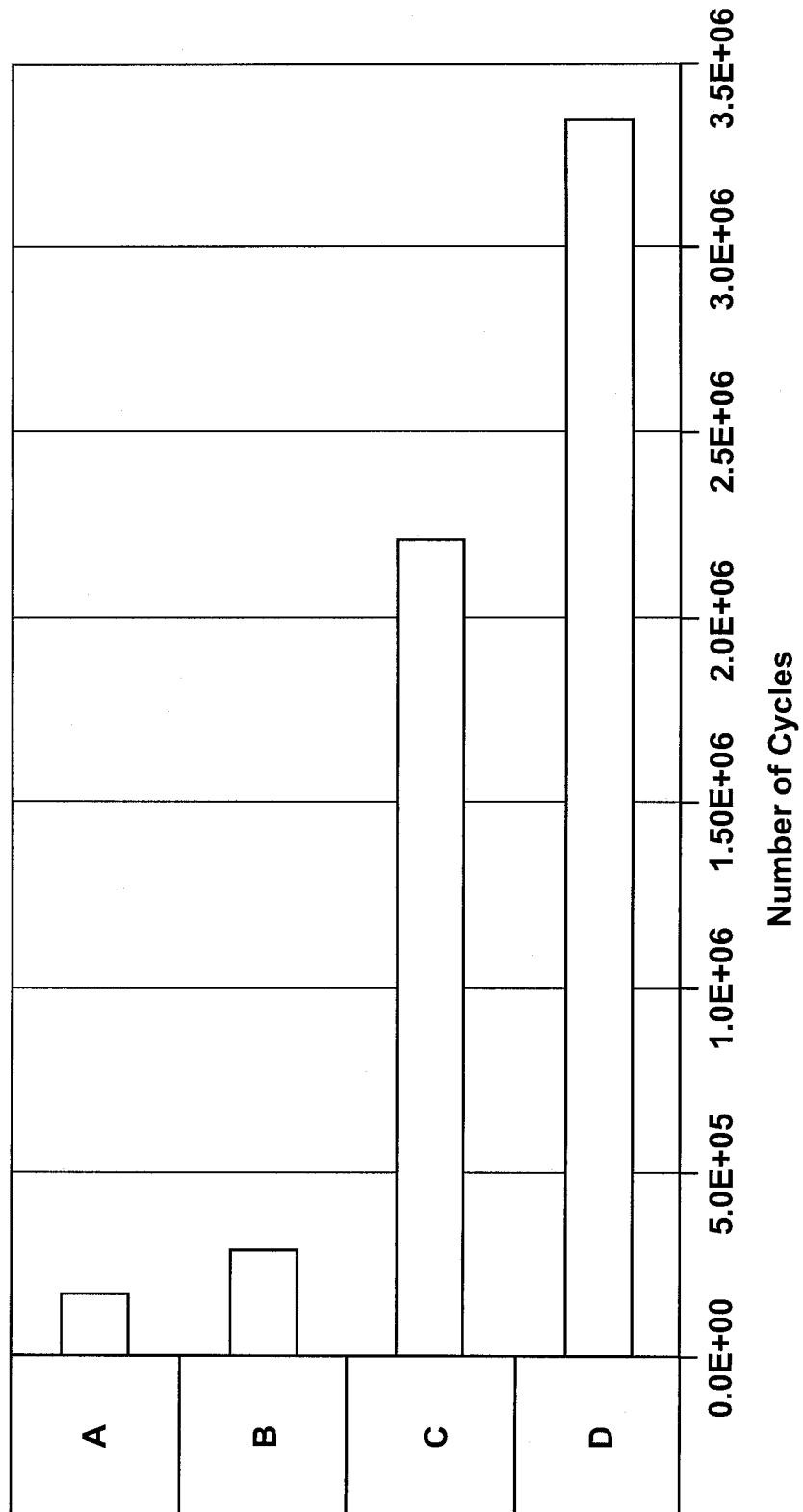

FIG. 10

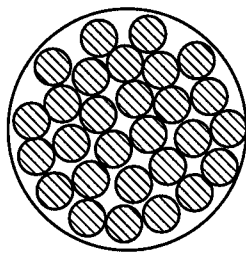

FIG. 11A

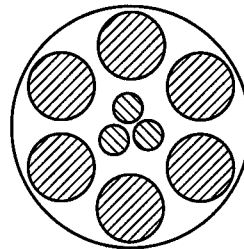

FIG. 11B

INTERNATIONAL SEARCH REPORT

International application No.
PCT/CA2008/001599

A. CLASSIFICATION OF SUBJECT MATTER IPC: B66B 23/24 (2006.01) , B32B 27/12 (2006.01) According to International Patent Classification (IPC) or to both national classification and IPC		
B. FIELDS SEARCHED		
Minimum documentation searched (classification system followed by classification symbols) IPC: B66B 23/24 (2006.01) , B32B 27/12 (2006.01) USPC: 198/337, 198/335		
Documentation searched other than minimum documentation to the extent that such documents are included in the fields searched		
Electronic database(s) consulted during the international search (name of database(s) and, where practicable, search terms used) Canadian Patent Database, Espacenet, WEST (stretch*, cable*, wire*, strand*, handrail, escalator, walkway)		
C. DOCUMENTS CONSIDERED TO BE RELEVANT		
Category*	Citation of document, with indication, where appropriate, of the relevant passages	Relevant to claim No.
X	CA2333553 A1 (CAUNCE, A. et al.) 13 January 2000 (13-01-2000) * fig 1, 2A, 2B, pg. 9 para. 3, pg.7 para.4, TABLE 1	1-14
A	CA2482620 A1 (KEUN, C.) 25 March 2005 (25-03-2005) * fig 1.	1-4, 14
A	US5160009 A (IYODA, H. et al.) 03 November 1992 (03-11-1992) * fig 2	5-13
A	US7404477 B1 (TOENNISSON H. et al.) 29 July 2008 (29-07-2008) * fig. 3	5-13
A	CA2343037 A1 (LEDZINSKI, J.) 23 March 2000 (23-03-2000) *fig. 2	5-13
A	JP2007084979 A (MIZUMA, K. et al.) 05 April 2007 (05-04-2007) * fig 5	15-22
[X] Further documents are listed in the continuation of Box C. [X] See patent family annex.		
* Special categories of cited documents :	"T"	later document published after the international filing date or priority date and not in conflict with the application but cited to understand the principle or theory underlying the invention
"A" document defining the general state of the art which is not considered to be of particular relevance	"X"	document of particular relevance; the claimed invention cannot be considered novel or cannot be considered to involve an inventive step when the document is taken alone
"E" earlier application or patent but published on or after the international filing date	"Y"	document of particular relevance; the claimed invention cannot be considered to involve an inventive step when the document is combined with one or more other such documents, such combination being obvious to a person skilled in the art
"L" document which may throw doubts on priority claim(s) or which is cited to establish the publication date of another citation or other special reason (as specified)	"&"	document member of the same patent family
"O" document referring to an oral disclosure, use, exhibition or other means		
"P" document published prior to the international filing date but later than the priority date claimed		
Date of the actual completion of the international search 11 December 2008 (11-12-2008)	Date of mailing of the international search report 18 December 2008 (18-12-2008)	
Name and mailing address of the ISA/CA Canadian Intellectual Property Office Place du Portage I, C114 - 1st Floor, Box PCT 50 Victoria Street Gatineau, Quebec K1A 0C9 Facsimile No.: 001-819-953-2476	Authorized officer Matthew Chisholm 819- 997-8812	

Box No. II Observations where certain claims were found unsearchable (Continuation of item 2 of the first sheet)

This international search report has not been established in respect of certain claims under Article 17(2)(a) for the following reasons :

1. Claim Nos. :
because they relate to subject matter not required to be searched by this Authority, namely :

2. Claim Nos. :
because they relate to parts of the international application that do not comply with the prescribed requirements to such an extent that no meaningful international search can be carried out, specifically :

3. Claim Nos. :
because they are dependent claims and are not drafted in accordance with the second and third sentences of Rule 6.4(a).

Box No. III Observations where unity of invention is lacking (Continuation of item 3 of first sheet)

This International Searching Authority found multiple inventions in this international application, as follows :

Group A: Claims 1-4 and 14 are directed to a hand rail with a thermoplastic material, a slider layer, and a cable array wherein outside cables of the cable array are offset inwardly in relation to the end walls of a lip portion.

Group B: Claims 5-13 are directed to a hand rail with a first layer of thermoplastic material, a second layer of thermoplastic material around the first layer, a slider layer, and a stretch inhibitor.

Group C: Claims 15-22 are directed to a hand rail with a first layer of thermoplastic material, a second layer of thermoplastic material around the first layer, a slider layer, and a cable array with a plurality of relatively larger outer strands and a plurality of relatively smaller inner strands. * *note, claim 23 is not included in these groups, see Box VII*

1. As all required additional search fees were timely paid by the applicant, this international search report covers all searchable claims.
2. As all searchable claims could be searched without effort justifying additional fees, this Authority did not invite payment of additional fees.
3. As only some of the required additional search fees were timely paid by the applicant, this international search report covers only those claims for which fees were paid, specifically claim Nos. :
4. No required additional search fees were timely paid by the applicant. Consequently, this international search report is restricted to the invention first mentioned in the claims; it is covered by claim Nos. :

Remark on Protest The additional search fees were accompanied by the applicant's protest and, where applicable, the payment of a protest fee.

The additional search fees were accompanied by the applicant's protest but the applicable protest fee was not paid within the time limit specified in the invitation.

No protest accompanied the payment of additional search fees.

INTERNATIONAL SEARCH REPORTInternational application No.
PCT/CA2008/001599

C (Continuation). DOCUMENTS CONSIDERED TO BE RELEVANT		
Category*	Citation of document, with indication, where appropriate, of the relevant passages	Relevant to claim No.
A	JP2007246176 A (KANAI, T. et al.) 27 September 2007 (27-09-2007) * figures	15-22
A	CA1261583 A1 (FISHER, M. et al.) 26 September 1989 (26-09-1989) *fig 12, 12A	15-22
A	CA898726 A (CAUNCE, A. et al.) 25 April 1972 (25-04-1972) * fig. 2	15-22

INTERNATIONAL SEARCH REPORT
Information on patent family members

International application No.
PCT/CA2008/001599

Patent Document Cited in Search Report	Publication Date	Patent Family Member(s)	Publication Date
CA 2333553A1	13-01-2000	AT 274466T	15-09-2004
		AU 4595299A	24-01-2000
		CA 2333553C	20-05-2008
		CN 1097027C	25-12-2002
		CN 1307537A	08-08-2001
		CZ 296854B6	12-07-2006
		CZ 20004436A3	11-07-2001
		DE 69919719D1	30-09-2004
		DE 69919719T2	01-09-2005
		EP 1098833A1	16-05-2001
		EP 1098833B1	25-08-2004
		ES 2228060T3	01-04-2005
		JP 3604687B2	22-12-2004
		JP 3645812B2	11-05-2005
		JP 2002519271T	02-07-2002
		JP 2004217431A	05-08-2004
		TW 460405B	21-10-2001
US 6237740B1	29-05-2001		
WO 0001607A1	13-01-2000		
CA 2482620A1	25-03-2005	DE 10344468A1	14-04-2005
		EP 1518816A2	30-03-2005
		EP 1518816A3	13-12-2006
		US 7200915B2	10-04-2007
		US 2005066500A1	31-03-2005
US 5160009A	03-11-1992	JP 2295888A	06-12-1990
		JP 2691028B2	17-12-1997
		JP 3106792A	07-05-1991
US 7404477B1	29-07-2008	None	
CA 2343037A1	23-03-2000	AT 153698A	15-07-2000
		AT 239664T	15-05-2003
		AT 407377B	26-02-2001
		BR 9913628A	22-05-2001
		CN 1113802C	09-07-2003
		CN 1316972A	10-10-2001
		DE 59905487D1	12-06-2003
		EP 1112219A1	04-07-2001
		EP 1112219B1	07-05-2003
		ES 2193743T3	01-11-2003
		JP 2002524372T	06-08-2002
		US 6673431B1	06-01-2004
		WO 0015536A1	23-03-2000
		JP 2007084979A	05-04-2007
JP 2007246176A	27-09-2007	None	
CA 1261583A1	26-09-1989	US 4618387A	21-10-1986
CA 898726A	25-04-1972	None	