

(19)
(12)

(KR)
(B1)

(51) 。 Int. Cl. ⁶
G11C 7/06

(45)
(11)
(24)

2002 09 05
10 - 0335397
2002 04 23

(21) 10 - 1998 - 0018884
(22) 1998 05 25

(65) 1999 - 0086095
(43) 1999 12 15

(73) 136 - 1

(72) 149 - 1 3 301 - 1707

(74)
:

(54)

1

2

1

2

3

1

2

3 1

4 2

10 : 20, 21 :

30 35 : 40 43 :

50 54 :

,
 (rambus DRAM) (synclink DRAM)
 / 가 .
 1
 (WL) 가 .
 2 (DRAM) (activation) (row address strobe : /RA
 S) (10) (WL_en)
 (20)가 (SE) ,
 (rto, /s) (30)가
 , (rto, /s)
 512 가 .
 , (sensing peak current)가 .
 , 가 (sensing peak current) rto /s
 , .
 , 가 가

1 2

1 2

3 (WL_en)

(21) n (40, 41, ...) (rto, /s) 가 (21) (SE) (SE) (21) n (40, 41, ...) (31, 32, 33, ...) (50, 51, 52, ...) (31, 32, 33, ...)

(SE)가 (SE)가 (rto, /s) 가 가 가

4 2 (MSB) n 2

2

(WL_en) (22) 가 (SE) (row address strobe : /RAS) (MSB) (y)

(NAND1, NAND2) (/y) 1 2 (NAND1, NAND2) 1 2 (42, 43) 1/ 2

(NAND, NAND2) 2/ 1 (43, 42) 3 4
(NAND3, NAND4) , 3 4 (NAND3, NAND4)
(rto, /s) 1 2 (34, 35) , 1 2
(34, 35) 1 2 (53,

54)

(42, 43)

가 가

(y)

(MSB)

(random column access)

, 2
3, 54)

1

(34, 35)

(5

(/RAS)가

(MSB)

가 가

n

n

가

가

가

가 가

(57)

1.

1

1

2

2

2.

1 ,

3.

1 ,

2 1 2 ,

1 2

1 2 ,

1 2

2 1

3 4

3 4

1 2

4.

3 ,

1 4

5.

3 ,

1 2

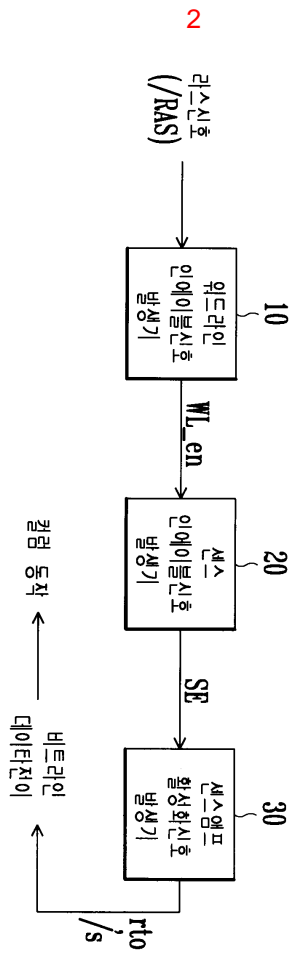
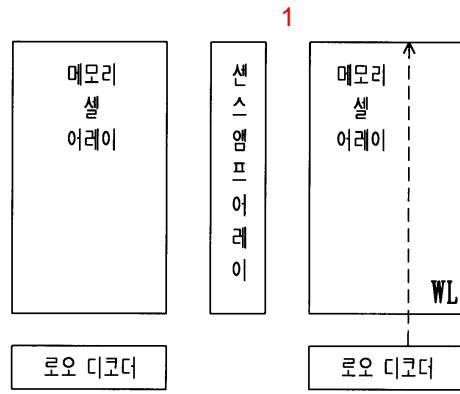

3

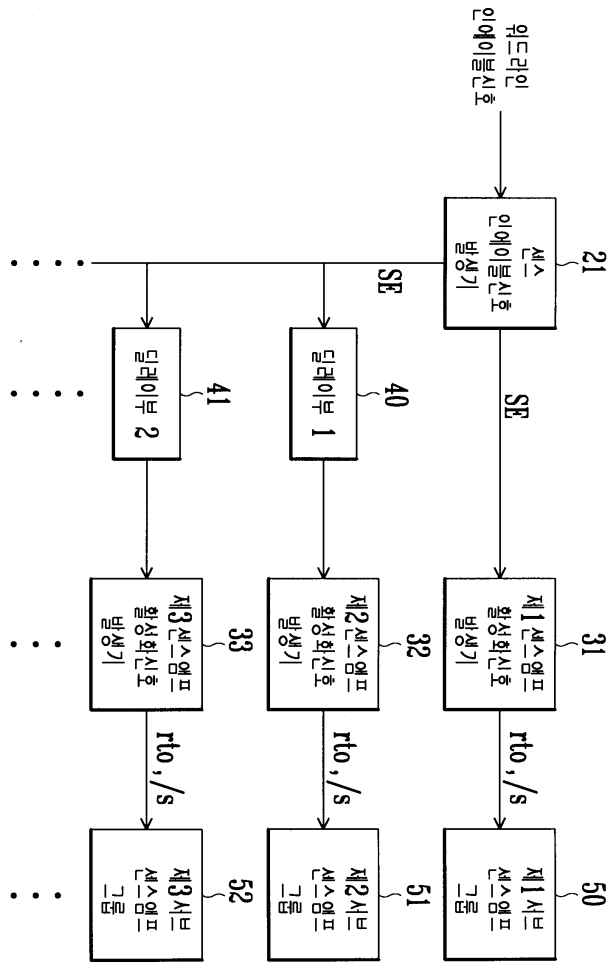

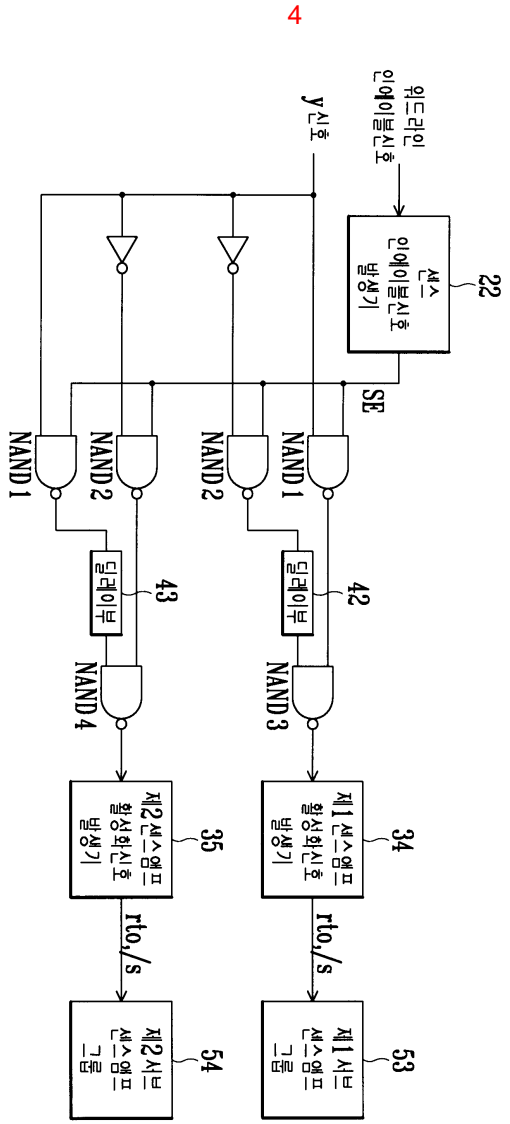

4