



US 20200080168A1

(19) **United States**

(12) **Patent Application Publication**

**Lee et al.**

(10) **Pub. No.: US 2020/0080168 A1**

(43) **Pub. Date: Mar. 12, 2020**

(54) **COOLING SYSTEM**

(30) **Foreign Application Priority Data**

(71) Applicant: **POSCO**, Pohang-si, Gyeongsangbuk-do (KR)

Dec. 16, 2016 (KR) ..... 10-2016-0172449

**Publication Classification**

(72) Inventors: **Pil-Jong Lee**, Pohang-si, Gyeongsangbuk-do (KR); **Jae-Jyung Seo**, Pohang-si, Gyeongsangbuk-do (KR); **Seong-Hyun Ko**, Pohang-si, Gyeongsangbuk-do (KR); **Jong-Hoon Kang**, Pohang-si, Gyeongsangbuk-do (KR); **Gwan-Sik Min**, Pohang-si, Gyeongsangbuk-do (KR)

(51) **Int. Cl.**  
*C21D 11/00* (2006.01)  
*C21D 9/52* (2006.01)  
*C21D 1/62* (2006.01)  
(52) **U.S. Cl.**  
CPC ..... *C21D 11/005* (2013.01); *C21D 1/62* (2013.01); *C21D 9/52* (2013.01)

(57) **ABSTRACT**

A cooling system according to an embodiment of the present invention may comprise: a cooling part which supplies a cooling fluid to a strip; and a boiling film removal part, which physically comes into contact with the strip and removes a boiling film formed by the cooling fluid. The boiling film removal part according to the embodiment may be disposed at a position where a nuclear boiling and a film boiling are mixed together along a widthwise direction of the strip.

(21) Appl. No.: **16/469,797**

(22) PCT Filed: **Dec. 15, 2017**

(86) PCT No.: **PCT/KR2017/014889**

§ 371 (c)(1),

(2) Date: **Jun. 14, 2019**

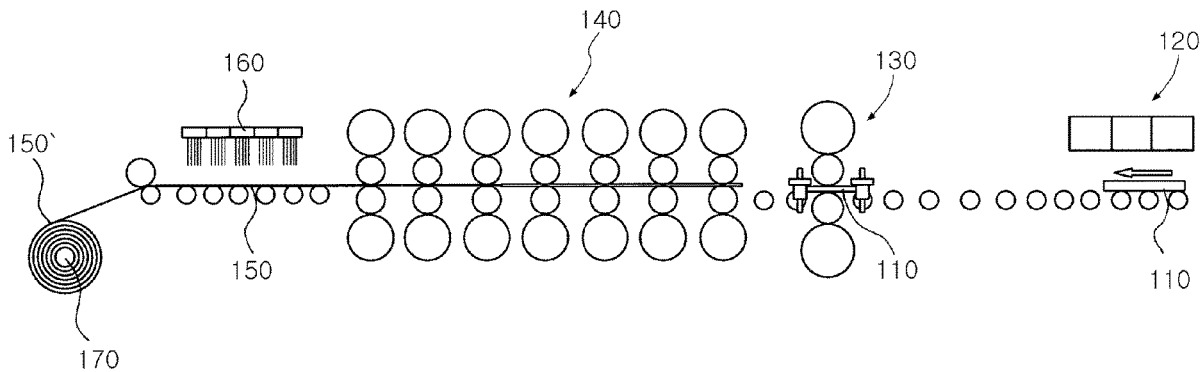

[FIG. 1]

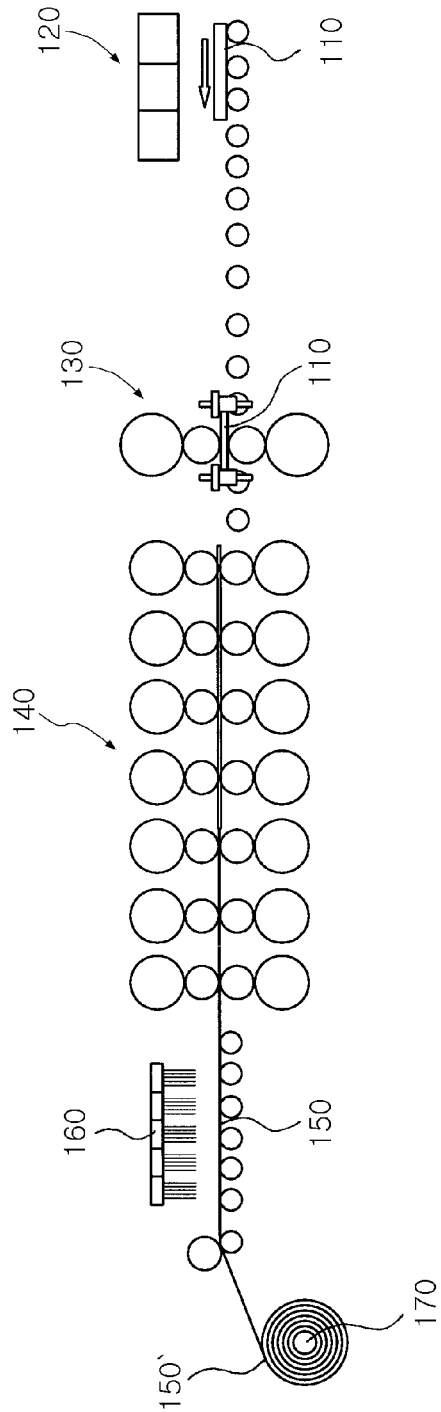

[FIG. 2]

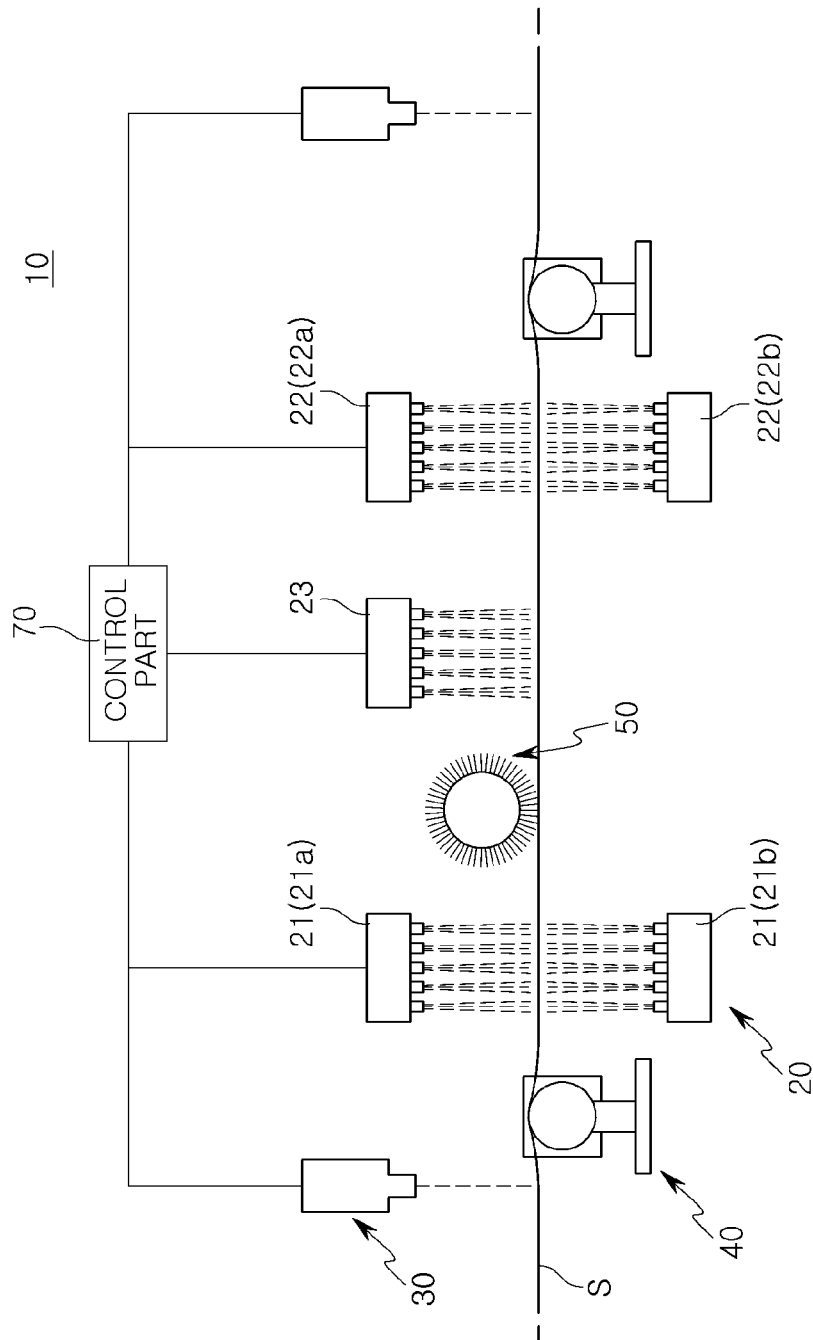

[FIG. 3]

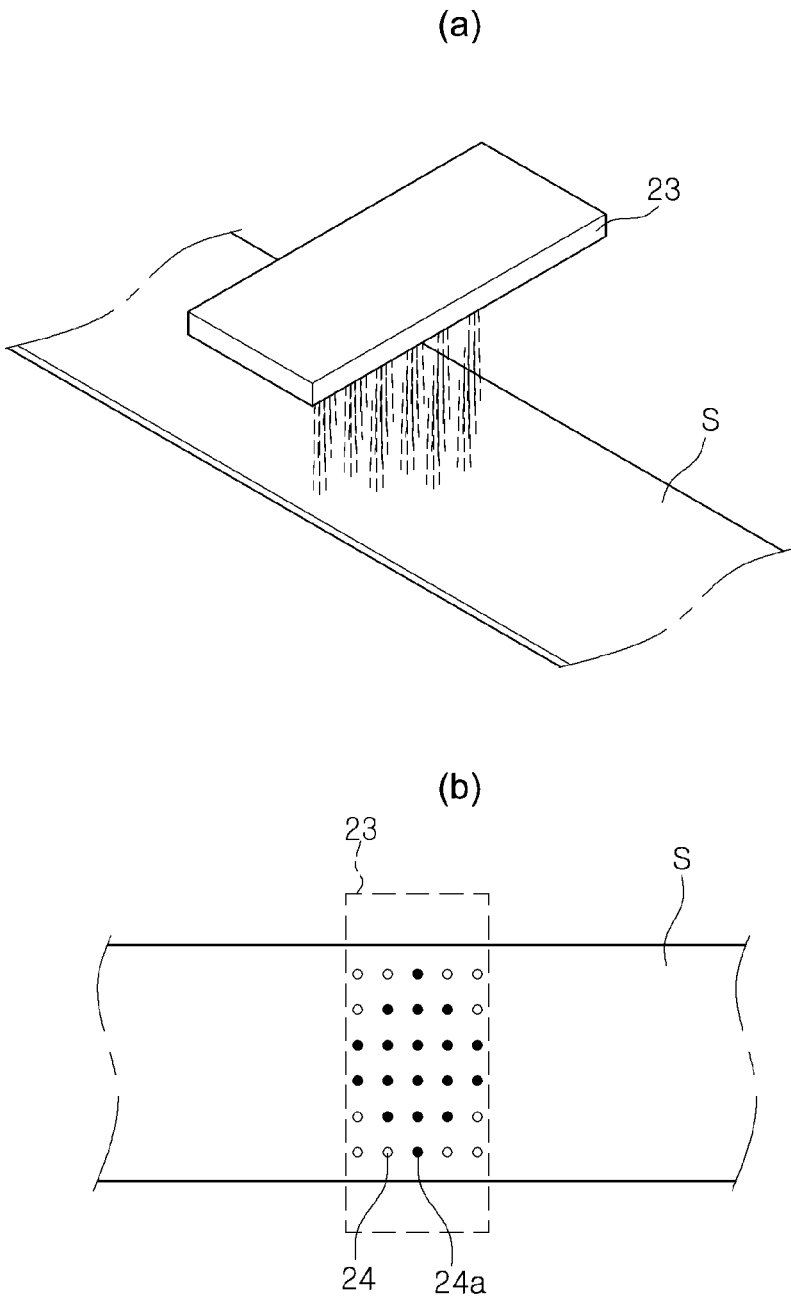

[FIG. 4]

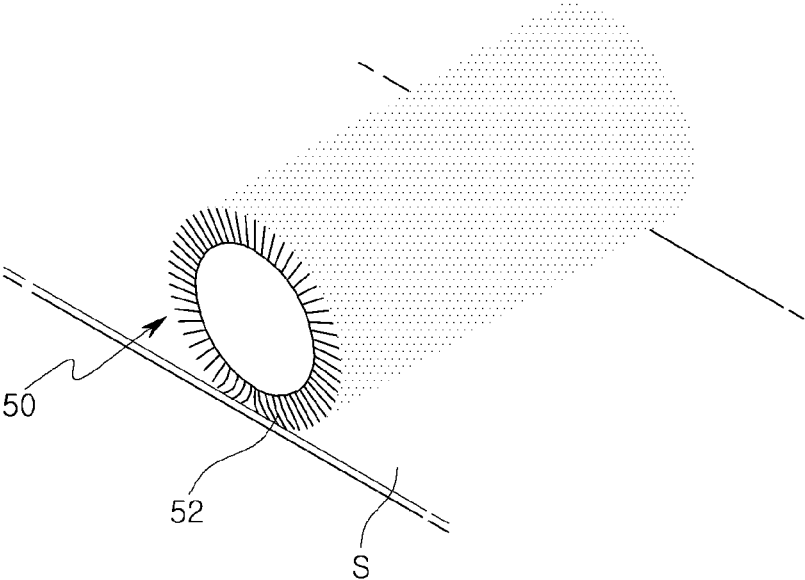

[FIG. 5]

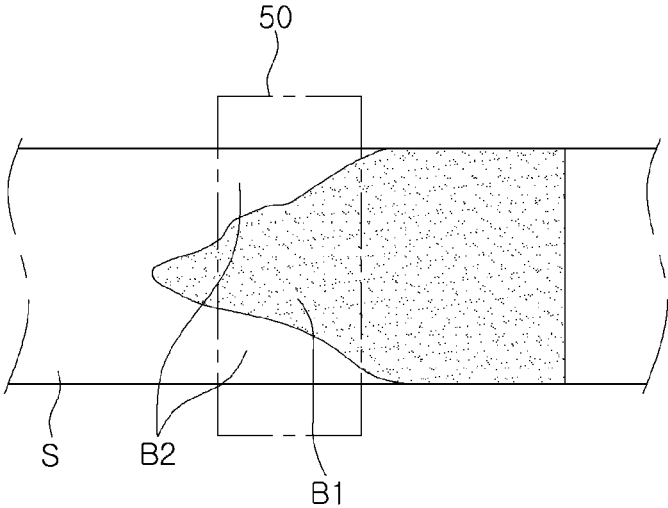

[FIG. 6]

10a

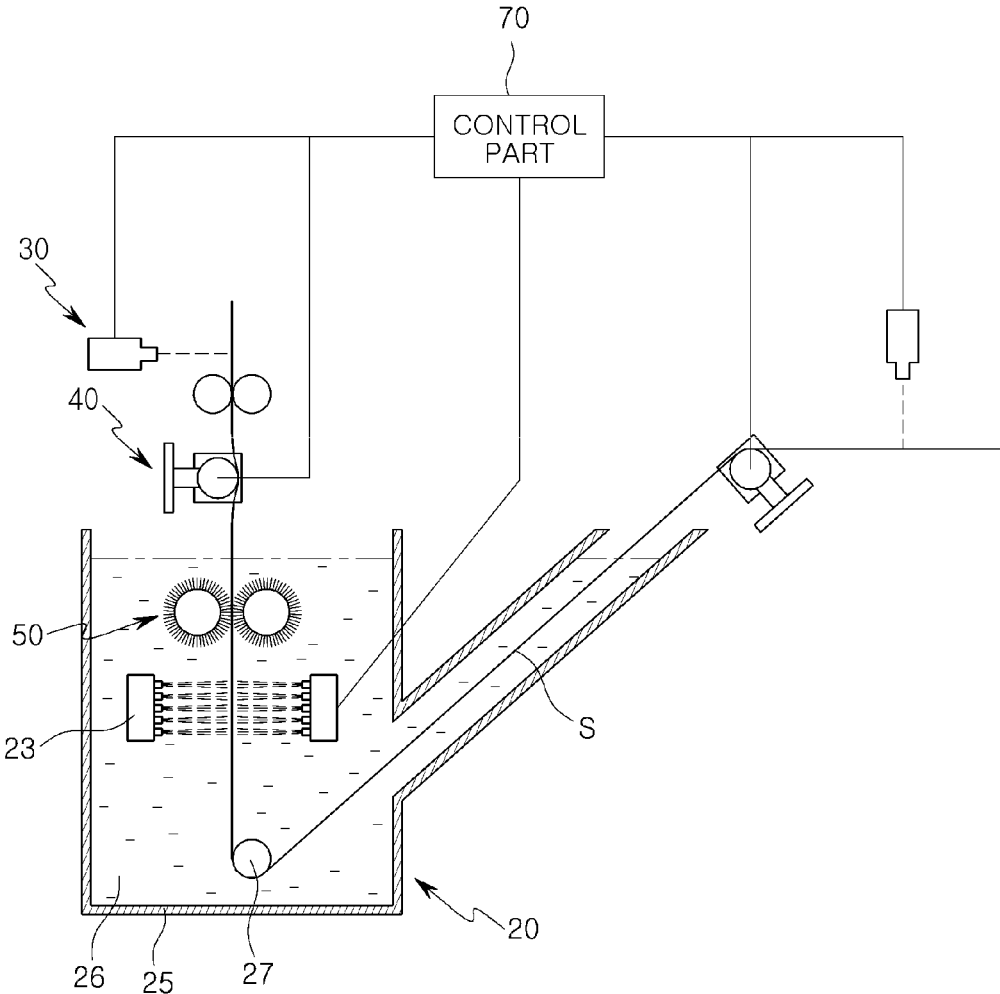

[FIG. 7]

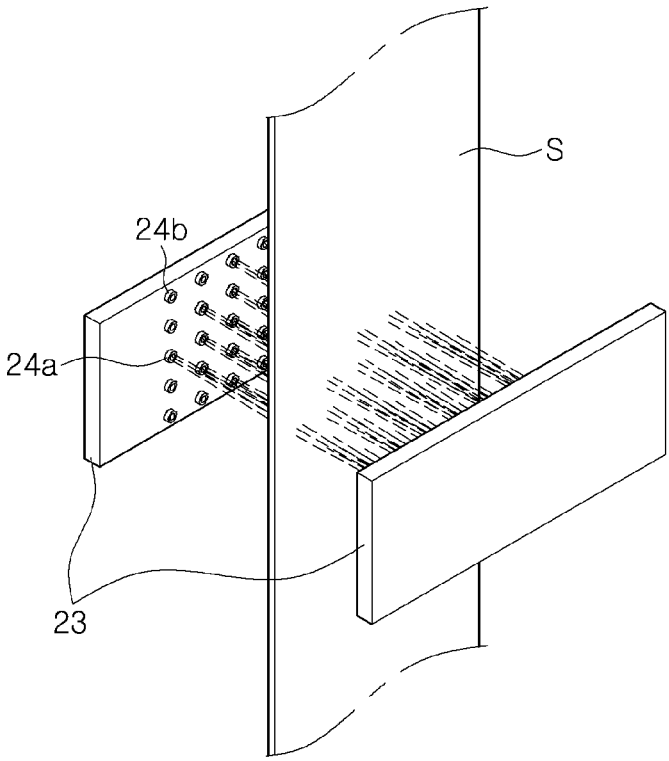

## COOLING SYSTEM

### TECHNICAL FIELD

**[0001]** The present disclosure relates to a cooling system of a strip.

### BACKGROUND ART

**[0002]** FIG. 1 illustrates a hot rolling process according to the related art.

**[0003]** As illustrated in FIG. 1, a slab **110**, a rolled material, is heated in a heating furnace **120** to a temperature appropriate for rolling, for example, 1100 to 1200 degrees Celsius. The heated slab **110** is rolled through a roughing mill **130** and a finishing mill **140** to be a strip **150** having a desired thickness.

**[0004]** The strip is cooled to a predetermined temperature, while passing through a run-out table **160**, to have required mechanical properties. The cooled strip is produced as a product in the form of a hot-rolled coil **150'** by a rewinder (a downcoiler) **170**, and a hot rolling process is completed.

**[0005]** For example, the hot-rolled slab **110**, heated in the heating furnace **120**, is changed in thickness and width by roughing rolling and finishing rolling. After being cooled on the run-out table **160**, the hot-rolled slab **110** is manufactured in a coil form **150'**.

**[0006]** Most quality of a hot-rolled steel sheet is determined during hot rolling. In the case of the related art, a run-out table injects cools a steel sheet by injecting cooling water onto the steel sheet as uniformly as possible through cooling nozzles mounted above and below the steel sheet.

**[0007]** However, in a cooling method using cooling water, an edge of a steel sheet in a widthwise direction is generally cooled first. Therefore, a great temperature deviation occurs in the widthwise direction to cause poor flatness of the steel sheet.

**[0008]** Additionally, in the case of a related art, a boiling film is formed due to vapor at the same time as a cooling phenomenon when a hot-rolled steel sheet is cooled using cooling water. In the case in which film boiling and nuclear boiling are mixed, a temperature deviation occurs in a cooling process to degrade quality of the hot-rolled steel sheet.

### DISCLOSURE

#### Technical Problem

**[0009]** An aspect of the present disclosure is to provide a cooling system which may significantly reduce temperature deviations of a steel sheet.

**[0010]** An aspect of the present disclosure is to provide a cooling system which may uniformly maintain flatness of a steel sheet.

#### Technical Solution

**[0011]** According to an aspect of the present disclosure, a cooling system includes a cooling part, supplying a cooling fluid to a strip, and a boiling film removal part physically coming into contact with the strip and removing a boiling film formed by the cooling fluid.

**[0012]** The boiling film removal part may have a shape of a roller.

**[0013]** The boiling film removal part may include a brush, disposed on an external circumferential surface of the roller,

and the brush may be partially brought into contact with the strip to remove the boiling film.

**[0014]** The boiling film removal part may be disposed in a position in which nuclear boiling and film boiling are mixed together in a widthwise direction of the strip.

**[0015]** The brush of the boiling film removal part may be formed of an acrylic material.

**[0016]** The cooling part may include a flow control cooling device disposed on a back end of the boiling film removal part and configured to control a flow rate based on a temperature deviation in the widthwise direction of the strip.

**[0017]** The cooling system may further include a temperature measurement part, disposed on at least one of a front end and a back end of the cooling part to measure a temperature of the strip, and a control part configured to control the flow control cooling device based on the temperature measured by the temperature measurement part.

**[0018]** The cooling system may further include a flatness measurement part, disposed on at least one of a front end and a back end of the cooling part to apply tension to the strip and to measure flatness of the strip, and a control part configured to control the flow control cooling device based on the flatness measured by the flatness measurement part.

**[0019]** The cooling part may include a cooling tank, in which a cooling fluid is contained, and the boiling film removal part may be disposed inside of the cooling fluid.

**[0020]** The boiling film removal part may be disposed in a location adjacent to a liquid surface of the cooling fluid in the cooling fluid.

**[0021]** According to an aspect of the present disclosure, a cooling system includes a measurement part, measuring a temperature deviation in a widthwise direction of a strip and flatness of the strip, and a flow control cooling device controlling a flow rate based on the temperature deviation or the flatness, measured by the measurement part, and injecting a cooling fluid onto the strip.

**[0022]** The measurement part may be disposed on both a front end and a back end of the flow control cooling device.

#### Advantageous Effects

**[0023]** As set forth above, a cooling system according to an example embodiment of the present disclosure cools a boiling film, formed on a strip, using a boiling film removal part. Flatness and temperature deviation of the strip are detected on an input side and an output side through a flatness measurement part and a temperature measurement part, respectively. Based on the flatness and the temperature deviation, an elongated portion or a high-temperature portion is selectively cooled using a cooling device which may adjust a flow distribution in a widthwise direction. As a result, the flatness of the strip may be improved.

### DESCRIPTION OF DRAWINGS

**[0024]** FIG. 1 illustrates of a hot rolling process according to a related art.

**[0025]** FIG. 2 is a schematic diagram of a cooling system according to an example embodiment of the present disclosure.

**[0026]** FIG. 3 illustrates a flow control cooling device in FIG. 2.

**[0027]** FIG. 4 illustrates the flow control cooling device in FIG. 2.

[0028] FIG. 5 illustrates a position in which a boiling film removal part is disposed on a strip.

[0029] FIG. 6 is a schematic diagram of a cooling system according to another example embodiment of the present disclosure.

[0030] FIG. 7 is a perspective view of a flow control cooling device in FIG. 6.

#### BEST MODE FOR INVENTION

[0031] Before describing the present disclosure in detail, it will be appreciated that terms or words used in the specification and claims should not be limited and construed as having common or dictionary meanings, and should be construed as having meanings and concepts according to the technical spirit of the present disclosure, based on the principle that the inventor can appropriately define the concept of each term for describing the present disclosure in the best manner. The example embodiment described in the present disclosure and the configuration illustrated in the drawings are merely the most preferred embodiment of the present disclosure, rather than representing all the technical concepts of the present disclosure, so the present disclosure is meant to cover all modifications, similarities and alternatives included in the spirit and scope of the present disclosure at the time of the filing of the present disclosure.

[0032] Hereinafter, example embodiments of the present disclosure will be described in detail with reference to the accompanying drawings. In each drawing, like reference numerals refer to like elements. Also, detailed descriptions of known functions and elements which unnecessarily obscure the important points of the descriptions will be omitted. Also, for the same reasons, in the drawings, some elements may be exaggerated, omitted, or schematically illustrated, and the size of each element does not entirely reflect an actual size.

[0033] Referring to FIG. 2, a cooling system 10 according to an example embodiment is configured to cool a rolled strip S and includes a cooling part 20, a temperature measurement part 30, a flatness measurement part 40, and a boiling film removal part 50. In this embodiment, the strip S includes a hot-rolled steel sheet, a high-temperature material.

[0034] The cooling part 20 injects cooling water to the strip S, conveyed from a finishing mill, to cool the strip S.

[0035] In this embodiment, the cooling part 20 includes a first cooling device 21, a second cooling device 22, and a flow control cooling device 23.

[0036] The first cooling device 21 is disposed on an input side of a cooling section, and the second cooling device 22 is disposed on an output side of the cooling section. The flow control cooling device 23 is disposed between the first cooling device 21 and the second cooling device 22.

[0037] The first cooling device 21 may include upper cooling devices 21a and 22a configured to inject a cooling fluid (hereinafter referred to as "cooling water") onto a top surface of the strip S. The second cooling device 22 may include lower cooling devices 21b and 22b configured to inject cooling water onto a bottom surface of the strip S. In this embodiment, the flow control cooling device 23 is disposed to inject cooling water onto only the top surface of the strip S. However, the configuration of the present disclosure is not limited thereto and, as necessary, the flow

control cooling device 23 may be configured to inject cooling water onto both top and bottom surfaces of the strip S.

[0038] The first cooling device 21 and the second cooling device 22 inject cooling water onto the entirety of the strip S. Thus, a cooling header according to a related art may be used as the first and second cooling devices 21 and 22.

[0039] On the other hand, the flow control cooling device 23 injects cooling water to a portion of the strip S to correspond to a temperature deviation of the strip S. Thus, a cooling header, capable of selectively driving a cooling nozzle configured to inject cooling water, may be used as the flow control cooling device 23.

[0040] FIG. 3 illustrates a flow control cooling device in FIG. 2.

[0041] Referring to FIG. 3, the flow control cooling device 23 may control a flow rate of cooling water injected in a widthwise direction of the strip S. Accordingly, the flow control 23 may inject a large amount of cooling water to a high-temperature portion of the strip S, and may inject a small amount of cooling water onto a low-temperature portion of the strip S or may stop injecting the cooling water.

[0042] Flow rate control may be performed by controlling nozzles 24a and 24b provided on a cooling header. The nozzles 24a and 24b may be disposed to have at least one row and at least column in the widthwise direction of the strip S. After a plurality of nozzles 24a and 24b are divided into a plurality of groups, nozzles 24a and 24b of each group may be opened and closed to inject a cooling fluid to a predetermined region.

[0043] In this case, a control part 70 may open at least one of the groups to selectively inject a cooling fluid 26 to a specific region. However, the configuration of the present disclosure is not limited thereto.

[0044] FIG. 3 illustrates a case in which cooling water is injected through only the specific nozzles 24a, among all nozzles 24a and 24b, and is not injected through the other nozzles 24b. In addition, FIG. 3 illustrates an operating example of the flow control cooling device 23 when temperature of a central portion of the strip S is high and temperature is decreased toward an edge of the strip S.

[0045] The temperature measurement part 30 may include a thermometer or a temperature sensor. The temperature measurement part 30 is disposed at an input side and an output side of a cooling section. For example, the temperature measurement part 30 may be disposed on at least one of a front end and a back end.

[0046] In this embodiment, the temperature measurement part 30 measures a temperature of the strip S at both a starting point and an ending point of the cooling section. However, the disposition of the temperature measurement part 30 is not limited thereto and, as necessary, the temperature measurement part 30 may be disposed on only the back end of the cooling part 20.

[0047] The temperature measurement part 30 is disposed in the widthwise direction of the strip S to measure a temperature of the strip S in the widthwise direction. Thus, a temperature deviation, depending on the widthwise direction of the strip S, may be continuously measured.

[0048] The flatness measurement part 40 includes a contact flatness meter brought into contact with the strip S to measure flatness of the strip S.

[0049] The flatness measurement part 40 is disposed below the strip S and is brought into contact with a bottom

surface of the strip S to elevate the strip S in an upward direction by a certain distance.

[0050] Accordingly, the strip S maybe brought into contact with the flatness measurement part 40 while tension is applied to the flatness measurement part 40. As a result, the flatness measurement part 40 may more precisely measure the flatness of the strip S.

[0051] In this embodiment, similarly to the temperature measurement part 30, the flatness measurement part 40 may be disposed on the input side and the output side of the cooling section. For example, the flatness measurement part 40 may be disposed on at least one of the front end and the back end of the cooling part 20. More specifically, the flatness measurement part 40 may be disposed between the temperature measurement part 30 and the cooling part 20.

[0052] Thus, the temperature and the flatness of the strip S are measured while the strip continuously passes through the temperature measurement part 30 and the flatness measurement part 40. However, the disposition of the flatness measurement part 40 is not limited thereto, and the flatness measurement part 40 may be disposed on only the back end of the cooling part 20.

[0053] The control part 70 is connected to the temperature measurement part 30 and the flatness measurement part 40 to receive temperature data from the temperature measurement part 30 and to receive flatness data from the flatness measurement part 40. The control part 70 controls a cooling header of the cooling part 20 based on the receive data to control an injection location, a flow rate, and the like of cooling water injected in the widthwise direction of the strip S.

[0054] Similarly to this embodiment, when the temperature measurement part 30 and the flatness measurement part 40 are mounted on the respective input and output sides of the cooling section, the control part 70 may control the flow control cooling device 23 by combining temperature distribution and flatness information of the strip S, entering the cooling section, with temperature distribution and flatness information of the strip S discharged from the cooling section.

[0055] For example, the control part 70 may continuously compare a state of the strip S, entering the cooling section, with a state of the strip S discharged from the cooling section, and may derive an optimal flow rate injection condition to correspond to various states of the strip S when the strip S enters the cooling section.

[0056] The boiling film removal part 50 is disposed between the first cooling device 21 and the flow control cooling device 23.

[0057] FIG. 4 illustrates the flow control cooling device in FIG. 2, and FIG. 5 illustrates a position in which a boiling film removal part is disposed on a strip.

[0058] Referring to FIG. 4, the boiling film removal part 50 is in the form of a roller having an external circumferential surface on which a brush 52 is disposed. For example, the brush 52 is formed to have a shape in which a plurality of brushes are densely arranged. For example, the brush 52 may be formed of an acrylic material. However, a material of the brush 52 is not limited thereto, and various materials may be used as the material of the brush 52 as long as they are not easily deformed at high temperature and do not deform the strip S even in contact with the strip S.

[0059] An external surface of the boiling film removal part 50 is not limited to a shape of the brush 52. The external

surface of the boiling film removal part 50 may have various shapes as along as a material of the boiling film removal part 50 may be brought into contact with the strip S to remove a boiling film on the strip S, for example, an external circumferential surface is in the form of foam or several sheets of mesh are wound on a roller.

[0060] When a cooling fluid 26 is injected to the strip S by the first cooling device 21, the strip S is cooled first. Thus, a boiling film such as film boiling, nuclear boiling or the like may be formed on a top surface of the strip S.

[0061] When temperature of the strip S reaches temperature at which film boiling and nuclear boiling are formed together (for example, 300 to 500 degrees Celsius), film boiling B1 and nuclear boiling B2 are irregularly mixed on the strip S, as illustrated in FIG. 5.

[0062] Since cooling speed of a portion, in which the film boiling B1 is formed, is different from cooling speed of a portion in which the nuclear boiling B2 is formed, a difference in cooling speed of the strip S occurs when the film boiling B1 and the nuclear boiling B2 are mixed. Accordingly, a cooling deviation occurs during a cooling process to have an effect on flatness of the strip S.

[0063] To address the above issue, the cooling device according to this embodiment includes the boiling film removal part 50.

[0064] The boiling film removal part 50 is brought into physical contact with the strip S, on which a boiling film is formed, while rotating and removing a boiling film in a manner of brushing off a boiling film formed on a top surface of the strip S.

[0065] The boiling film removal part 50 may be disposed in a location where the boiling film transitions from the film boiling B1 to the nuclear boiling B2 on the strip S.

[0066] Accordingly, the boiling film removal part 50 may remove a boiling film of a portion in which the film boiling B1 and nuclear boiling B2 are mixed. As a result, a temperature deviation, caused by the film boiling B1 and the nuclear boiling B2 in a widthwise direction of the strip S, may be significantly reduced.

[0067] The above-described flow control cooling device 23 is disposed on a back end of the boiling film removal part 50. Thus, the flow control cooling device 23 injects the cooling fluid 26 on the strip S on which the boiling film is significantly reduced, and injects a large amount of cooling water to a high-temperature portion and injects a small amount of cooling water to a low-temperature portion to correspond to a temperature deviation.

[0068] As a result, a cooling effect may be significantly improved and a temperature deviation in the widthwise direction of the strip S may be efficiently reduced.

[0069] A case, in which the cooling system 10 includes both the temperature measurement part 30 and the flatness measurement part 40, has been described in this embodiment. However, the configuration of the cooling system 10 is not limited thereto, and the cooling system 10 may be configured to include only one of the temperature measurement part 30 and the flatness measurement part 40.

[0070] The above-configured cooling system 10 removes a boiling film, formed on the strip S, using the boiling film removal part 50 and cools the strip S. In addition, the cooling system 10 detects flatness and temperature deviation of the strip S on an input side and an output side through the flatness measurement part 40 and the temperature measurement part 30 and selectively cools an elongated portion or a

high-temperature portion, based on the flatness and the temperature deviation, using a cooling device which may adjust a flow distribution in a widthwise direction.

[0071] Accordingly, a strip S, having an entirely uniform temperature distribution and improved flatness, may be manufactured.

[0072] A cooling system according to the present disclosure is not limited to the above-described embodiment, and may be variously modified.

[0073] FIG. 6 is a schematic diagram of a cooling system according to another example embodiment of the present disclosure, and FIG. 7 is a perspective view of a flow control cooling device in FIG. 6.

[0074] Referring to FIGS. 6 and 7, a cooling system 10a is configured to cool a strip S while vertically moving the strip S and is disposed in such a manner that the strip S passes through a cooling tank 25 in which a cooling liquid 26 is contained.

[0075] To this end, similarly to the above-described embodiment, the cooling system 10a includes a cooling part 20, a temperature measurement part 30, a flatness measurement part 40, a boiling film removal part 50, and a cooling tank 25. The temperature measurement part 30, the flatness measurement part 40, and the boiling film removal part 50 are disposed, similarly to the above-described embodiment, on the basis of a moving direction of a strip S to perform the same functions as those in the above-described embodiment. Therefore, detailed descriptions of the above components will be omitted and only differences thereof will be described in detail. In this embodiment, the strip S may include a cold-rolled steel sheet.

[0076] The cooling part 20 includes a cooling tank 25 in which a cooling fluid 26 is contained. The strip S is vertically moved, and is introduced into the cooling tank 25 and is drawn out of the cooling tank 25 after being moved by a predetermined distance. Accordingly, inside of the cooling tank 25 is provided with a plurality of guide rolls 27 supporting and guiding the strip S to achieve smooth movement of the strip S.

[0077] As necessary, the cooling part 20 may further include a cooling device, not illustrated, configured to inject the cooling fluid 26 to the strip S. The cooling device may be disposed inside or outside of the cooling fluid 26. The cooling device may have a configuration similar to the configuration of each of the first and second cooling devices according to the above-described embodiment, and detailed description thereof will be omitted.

[0078] In this embodiment, the boiling film removal part 50 may be disposed inside the cooling tank 25.

[0079] When the strip enters inside of the cooling fluid 26 of the cooling tank 25, film boiling and nuclear boiling may be apt to be mixed on a surface of the strip S. Therefore, in this embodiment, the boiling film removal part 50 may be disposed inside of the cooling fluid 26 and disposed in a location adjacent to a liquid surface of the cooling liquid 26. More specifically, similarly to the above-described embodiment, the boiling film removal part 50 is disposed in a location where a boiling film transitions from film boiling to nuclear boiling on the strip S.

[0080] Similarly to the above-described embodiment, the boiling film removal part 50 may remove a boiling film of a portion, in which film boiling and nuclear boiling are

mixed, to significantly reduce a temperature deviation caused by the film boiling and nuclear boiling in a widthwise direction of the strip S.

[0081] In this embodiment, the boiling film removal part 50 is disposed on both surfaces of the strip S. However, a configuration of the boiling film removal part 50 is not limited thereto.

[0082] A flow control cooling device 23 is disposed on a back end of the boiling film removal part 50 and partially injects cooling water or cooling gas to the strip S according to control of a control part 70.

[0083] In this embodiment, the flow control cooling device 23, disposed on both surfaces of the strip S to simultaneously inject cooling water onto both surfaces of the strip S, is illustrated. However, a disposition of the flow control cooling device 23 is not limited thereto and, similarly to the above-described embodiment, the flow control cooling device 23 may be disposed on only one surface of the strip S.

[0084] A case, in which a cooling device is used to cool a hot-rolled steel sheet and a cold-rolled steel sheet, has been described in the above embodiments. However, as necessary, the cooling device may be used to cool various materials such as an electrical steel sheet, a stainless steel (STS), a thick steel sheet, and the like.

[0085] While embodiments have been shown and described above, it will be apparent to those skilled in the art that modifications and variations could be made without departing from the scope of the present disclosure as defined by the appended claims.

1. A cooling system comprising:

a cooling part which supplies a cooling fluid to a strip; and  
a boiling film removal part which physically comes into contact with the strip and removes a boiling film formed by the cooling fluid.

2. The cooling system of claim 1, wherein the boiling film removal part has a shape of a roller.

3. The cooling system of claim 2, wherein the boiling film removal part includes a brush, disposed on an external circumferential surface of the roller, and the brush is partially brought into contact with the strip to remove the boiling film.

4. The cooling system of claim 1, wherein the boiling film removal part is disposed in a position where a nuclear boiling and a film boiling are mixed together along a widthwise direction of the strip.

5. The cooling system of claim 3, wherein the brush of the boiling film removal part is formed of an acrylic material.

6. The cooling system of claim 1, wherein the cooling part includes a flow control cooling device disposed on a back end of the boiling film removal part and configured to control a flow rate based on a temperature deviation in the widthwise direction of the strip.

7. The cooling system of claim 6, further comprising:

a temperature measurement part disposed on at least one of a front end and a back end of the cooling part to measure a temperature of the strip; and

a control part configured to control the flow control cooling device based on the temperature measured by the temperature measurement part.

- 8.** The cooling system of claim **6**, further comprising:  
a flatness measurement part disposed on at least one of a front end and a back end of the cooling part to apply tension to the strip and to measure flatness of the strip;  
and  
a control part configured to control the flow control cooling device based on the flatness measured by the flatness measurement part.
- 9.** The cooling system of claim **1**, wherein the cooling part includes a cooling tank in which a cooling fluid is contained,  
and  
the boiling film removal part is disposed inside of the cooling fluid.
- 10.** The cooling system of claim **9**, wherein the boiling film removal part is disposed in a location adjacent to a liquid surface of the cooling fluid in the cooling fluid.
- 11.** A cooling system comprising:  
a measurement part measuring a temperature deviation in a widthwise direction of a strip and flatness of the strip;  
and  
a flow control cooling device controlling a flow rate based on the temperature deviation or the flatness, measured by the measurement part, and injecting a cooling fluid to the strip.
- 12.** The cooling system of claim **11**, wherein the measurement part is disposed on both a front end and a back end of the flow control cooling device.

\* \* \* \* \*