

(19) World Intellectual Property Organization
International Bureau



(43) International Publication Date
13 December 2007 (13.12.2007)

PCT

(10) International Publication Number
WO 2007/142996 A2

- (51) International Patent Classification:
B25C 1/06 (2006.01)
- (21) International Application Number:
PCT/US2007/012783
- (22) International Filing Date: 31 May 2007 (31.05.2007)
- (25) Filing Language: English
- (26) Publication Language: English
- (30) Priority Data:
60/809,368 31 May 2006 (31.05.2006) US
- (71) Applicant (for all designated States except US): STANLEY FASTENING SYSTEMS, L.P. [US/US]; Route 2, Briggs Drive, East Greenwich, RI 02818 (US).
- (72) Inventors; and
- (75) Inventors/Applicants (for US only): MILLER, Keven [US/US]; 97 New London Turnpike, Wyoming, RI 02898 (US). SIMONELLI, David [US/US]; 35 Clark Mill St., Coventry, RI 02816 (US). HEWITT, Charles, W.

- [US/US]; 406 Sea View Drive, Warwick, RI 02889 (US). PALM, William [US/US]; 545 Mt. Auburn Street, #1, Watertown, MA 02472 (US).
- (74) Agents: VAN DYKE, Raymond et al.; Nixon Peabody LLP, 401 9th Street, N.W., Suite 900, Washington, DC 20004 (US).
- (81) Designated States (unless otherwise indicated, for every kind of national protection available): AE, AG, AL, AM, AT, AU, AZ, BA, BB, BG, BH, BR, BW, BY, BZ, CA, CH, CN, CO, CR, CU, CZ, DE, DK, DM, DO, DZ, EC, EE, EG, ES, FI, GB, GD, GE, GH, GM, GT, HN, HR, HU, ID, IL, IN, IS, JP, KE, KG, KM, KN, KP, KR, KZ, LA, LC, LK, LR, LS, LT, LU, LY, MA, MD, ME, MG, MK, MN, MW, MX, MY, MZ, NA, NG, NI, NO, NZ, OM, PG, PH, PL, PT, RO, RS, RU, SC, SD, SE, SG, SK, SL, SM, SV, SY, TJ, TM, TN, TR, TT, TZ, UA, UG, US, UZ, VC, VN, ZA, ZM, ZW.
- (84) Designated States (unless otherwise indicated, for every kind of regional protection available): ARIPO (BW, GH, GM, KE, LS, MW, MZ, NA, SD, SL, SZ, TZ, UG, ZM, ZW), Eurasian (AM, AZ, BY, KG, KZ, MD, RU, TJ, TM),

[Continued on next page]

(54) Title: FASTENER DRIVING DEVICE WITH A PLANETARY GEAR CABLE LIFT AND RELEASE MECHANISM

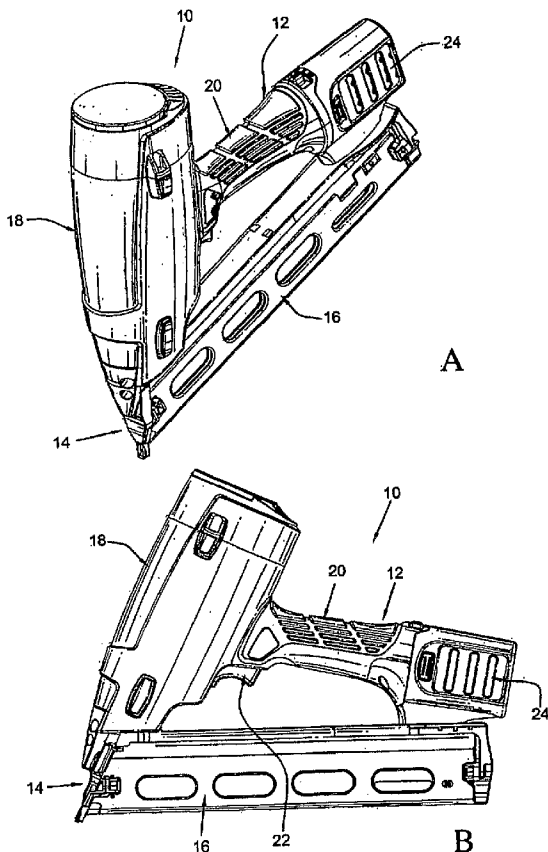

(57) Abstract: A fastener driving device including a fastener driver displaceable to drive a fastener, a spring adapted to move the fastener driver through a drive stroke, and a cable for compressing the spring and moving the fastener driver through a retraction stroke. The cable may be connected to a drum and a motor is used to rotate the drum to pull the cable and compress the spring. A set of planetary gears and a clutch may be used to connect the motor to the drum.

WO 2007/142996 A2



European (AT, BE, BG, CH, CY, CZ, DE, DK, EE, ES, FI, FR, GB, GR, HU, IE, IS, IT, LT, LU, LV, MC, MT, NL, PL, PT, RO, SE, SI, SK, TR), OAPI (BF, BJ, CF, CG, CI, CM, GA, GN, GQ, GW, ML, MR, NE, SN, TD, TG).

For two-letter codes and other abbreviations, refer to the "Guidance Notes on Codes and Abbreviations" appearing at the beginning of each regular issue of the PCT Gazette.

Published:

- *without international search report and to be republished upon receipt of that report*

FASTENER DRIVING DEVICE WITH A
PLANETARY GEAR CABLE LIFT AND RELEASE MECHANISM

[0001] This application claims priority to U.S. Provisional Application No. 60/809,368 filed May 31, 2006, the contents of which are incorporated herein by reference.

BACKGROUND OF THE INVENTION

Field of the Invention

[0002] The present invention is directed to a fastener driving device that utilizes a spring to drive a fastener. In particular, the present invention is directed to such a fastener driving device having a mechanism to compress, and release, the spring.

Description of Related Art

[0003] Fastener driving tools are designed to drive fasteners very quickly into a workpiece. Typically, fastener driving devices use energy sources such as compressed air, flywheels, and chemicals (fuel combustion & gun powder detonation) to provide the energy required to drive the fasteners. In some fastener driving tools, springs are used to provide the required drive energy. For example, U.S. Patent No. 6,899,260 to Sun discloses a small, cordless brad tool that utilizes a steel spring to provide the drive energy. U.S. Patent No. 6,997,367 to Hu also discloses a hand held nailing tool for firing small nails, the nailing tool utilizing a spring to provide the drive energy. Of course, in such fastener driving tools, some mechanism is required to compress, and release, the spring that is used. In this regard, the '260 patent discloses use of gear wheels, while

-2-

the '367 patent discloses a transmission gear set that engages a striking mechanism.

[0004] It is desirable for fastener driving devices to provide sufficient energy to effectively drive the fastener, but with minimum recoil. Recoil negatively impacts a tool's ability to drive a fastener, and, it may also increase user fatigue. Recoil is a function of, among other things, the tool weight/driver weight ratio, and driver velocity (drive time). It is also desirable for the tool to be of low weight so that it may be used with one hand, and not cause excessive fatigue to the user.

[0005] The above described fastener driving devices can only drive small fasteners such as brad nails and finishing nails, and are not suitable for driving larger fasteners such as structural nails. This is, in part, due to the fact that the spring that can drive larger fasteners must be very strong and robust, while at the same time, capable of releasing energy very rapidly. Correspondingly, the mechanism for lifting and releasing of the spring also has to be strong and robust, which undesirably adds to the size and weight of the fastener driving device.

[0006] U.S. Patent Nos. 7,137,541 and 7,138,595 are peripherally related to the present invention in that each discloses a portable fastener driving device having an energy storage device. However, the energy storage device is a flywheel which provides the energy to drive the fastener. Such fastener driving devices have been found to be inefficient in portable implementations in that they are heavy and waste energy to maintain the stored energy in the flywheel as required to drive the fastener.

[0007] Therefore, there exists an unfulfilled need for a fastener driving device that utilizes a spring to efficiently drive fasteners, including larger fasteners. There also exists an unfulfilled need for such a fastener driving device having a mechanism for efficiently compressing and releasing the spring.

-3-

SUMMARY OF THE INVENTION

[0008] In view of the foregoing, an advantage of the present invention is in providing a fastener driving device in which a spring is used to drive the fastener.

[0009] Another advantage of the present invention is in providing a fastener driving device with a mechanism for compressing and releasing the spring in an efficient manner.

[0010] Still another advantage of the present invention is in providing such a fastening device that is mechanically efficient, to thereby allow a high number of operational cycles in those implementations where the fastener driving tool is portable.

[0011] Yet another advantage of the present invention is in providing a fastener driving device with a cable lift and release mechanism, having planetary gear assemblies, that compresses and releases the spring.

[0012] These and other advantages and features of the present invention will become more apparent from the following detailed description of the preferred embodiments of the present invention when viewed in conjunction with the accompanying drawings.

BRIEF DESCRIPTION OF THE DRAWINGS

[0013] Figure 1A is a perspective view of a fastener driving device in accordance with one embodiment of the present invention.

[0014] Figure 1B is a side perspective view of the fastener driving device of Figure 1A.

[0015] Figure 2 is a front view of the cable lift and release mechanism in accordance with one implementation of the present invention.

[0016] Figure 3 is a top view of the cable lift and release mechanism of Figure 2.

-4-

[0017] Figure 4 is a cross-sectional view of the cable lift and release mechanism of Figures 2 and 3, as viewed along A-A of Figure 3.

[0018] Figure 5A and 5B are partial sectional views of the cable lift and release mechanism of Figure 2 that more clearly show first planetary gear assembly.

[0019] Figure 6A and 6B are partial sectional views of the cable lift and release mechanism of Figure 2 that more clearly show the second planetary gear assembly.

[0020] Figure 7 is an enlarged elevation view of the latch being engaged by the spring carriage.

DETAILED DESCRIPTION OF THE PREFERRED EMBODIMENT

[0021] Figures 1A and 1B illustrate a perspective view of a fastener driving device 10 in accordance with one embodiment of the present invention. As will be evident from the discussion below, the fastener driving device 10 is implemented to utilize a spring for driving a fastener into a workpiece. The fastener driving device 10 is implemented with a mechanism for rapidly compressing and releasing the spring. In this regard, the fastener driving device 10 is mechanically efficient to allow high number operational cycles in those implementations where the fastener driving tool is made to be portable, such as in the embodiment shown in Figures 1A and 1B.

[0022] As shown, the fastener driving device 10 includes a housing assembly 12, a nose assembly 14, and a magazine 16 that is operatively connected to the nose assembly 14 and supported by the housing assembly 12. The housing assembly 12 also includes a handle portion 20 that extends away from the main housing portion 18, as shown. The handle portion 20 is configured to be gripped by the user of the fastener driving device 10. The device 10 also includes a cable lift and release mechanism that is housed in the main housing portion 18 of the housing assembly 12, the mechanism being constructed and arranged to drive

-5-

fasteners supplied by the magazine 16 into a workpiece in the manner described herein.

[0023] The nose assembly 14 includes a drive track (not shown) that is configured to receive a fastener driver (not shown). The drive track is constructed and arranged to receive fasteners, such as nails, staples, and the like, from the magazine 16 so that they may be driven by the fastener driver, one by one, into the workpiece. A trigger 22 is provided for actuating the fastener driving device 10 to drive the fasteners. These features are known in the art, and not critical to understanding the present invention. Thus, details of these features are omitted herein.

[0024] As noted, in the illustrated embodiment, the fastener driving device 10 is implemented to be portable and cordless. Thus, a source of energy is also provided on the fastener driving device 10 such as battery 24 in the illustrated implementation. However, it should be understood that the present invention is not limited in any way to portable implementations, and other types of power sources may be used for powering the motor in other implementations. For example, the fastener driving device may be electrically operated with a power cord connected to an outlet, or be pneumatically operated. In addition, a fuel cell may be utilized to allow the fastener driving device to be implemented in a portable manner. Of course, these are examples only, and the power source may be implemented differently in other embodiments.

[0025] Figures 2 to 7 show various views of the cable lift and release mechanism 30 in accordance with one preferred implementation of the present invention which is housed within the main housing portion 18. Referring to these figures, and in particular, to the cross sectional view of Figure 4, the cable lift and release mechanism 30 includes a spring carriage 32, and a spring 34 that is partially received in the spring carriage 32. A fastener driver 35 (not shown) that engages a fastener to drive the fastener into the workpiece is connected to the spring carriage 32 in a manner known. The spring carriage 32 is also connected to a cable 36, the pulling and retraction of the cable 36 causing the

-6-

lifting of the spring carriage 32 in a retraction or return stroke, and corresponding compression of the spring 34, to thereby store energy therein. In this regard, one end of the cable 36 is fixed to the spring carriage 32 via a pinch plate 37. As clearly shown in Figure 4, the cable 36 is preferably positioned on the line of action of spring 34 to minimize eccentric compression of the spring 34 as the spring carriage 32 is lifted. The top of the spring 34 is restrained by a spring seat 38.

[0026] As discussed in detail below, the energy stored in the spring 34 is released by releasing the tension in the cable 36, which allows the spring 34 to decompress, and displace the spring carriage 32 (downwardly in Figure 4), so that the fastener driver attached to the spring carriage 32 moves through a drive stroke to drive the fastener through the nose assembly 14, and into the workpiece. Thus, when the tension in the cable 36 is released, the spring carriage 32 axially translates freely along the line of action of the spring 34 as the spring decompresses. In the illustrated embodiment, the displacement of the spring carriage 32 is restrained by the bumper 39 which is fixed within the main housing portion 18.

[0027] As most clearly shown in Figure 4, the cable 36 is routed over sheaves 40 which are free to rotate as the cable 36 moves thereon during lifting and releasing of the spring carriage 32. The other end of cable 36 is fixed to a cable drum 42 which rotates about its own axis. In the illustrated embodiment, the cable drum 42 and the sheaves 40 have appropriately designed grooves to keep the cable 36 properly aligned thereon. In the illustrated embodiment, the diameter of the cable drum 42 is such that less than 360 degrees of rotation of cable drum 42 is required to achieve spring compression required for a full drive stroke. Preferably, approximately 270 degrees of rotation is used to take up approximately 3.5" of the cable 36, so that the spring carriage 32 is correspondingly lifted to compress the spring 34. A drum stop pin 44 shown in Figure 2 is fixed to the cable drum 42, and engages the drum bumper 46 to stop

-7-

the rotational momentum of the cable drum 42 after the release of the spring carriage 32.

[0028] The lifting of the spring carriage 32 and the corresponding compression of the spring 34 in the manner discussed above, is attained by the motor 50 most clearly shown in Figures 3, and 5A to 6B. The motor 50 converts the electrical energy provided by the battery 24, to mechanical work, to rotate the cable drum 42, to thereby retract the cable 36, and lift the spring carriage 32 to compress the spring 34 during the retraction or return stroke. In the preferred implementation, the motor 50 is a DC motor.

[0029] To mechanically connect the motor 50 to the cable drum 42 to allow rotation thereof, the cable lift and release mechanism 30 includes a clutch 54 which is most clearly shown in the top view Figure 3. The cable lift and release mechanism 30 of the illustrated embodiment also includes a first stage planetary gear assembly 60 also shown in Figure 3, and a gear housing 56 which houses a second stage planetary gear assembly 70 and the cable drum 42 shown in Figure 5A. These planetary gear assemblies are also clearly shown in Figures 6A and 6B with their ring gears removed for clarity purposes. These planetary gear assemblies are used in the cable lift and release mechanism 30 to achieve high gear reductions in a small, compact assembly, and to provide differing gear ratios depending on the relative motion of the different gears, i.e. which gear is the input, which gear is the output, and which gear is stationary.

[0030] In particular, in the illustrated embodiment, the motor 50 is coupled to the clutch 54, which in turn, is coupled to the planetary gear assemblies. The clutch 54 functions to lock the output shaft of the planetary gear assemblies when the shaft of the motor 50 is stationary, the motor shaft essentially functioning as the input sun gear for the first planetary gear assembly 60. The ring gear 62 for the first planetary gear assembly 60 shown in Figure 3 (but not shown for clarity purposes in Figures 5A to 6B) is held fixed by the housing 56. The first stage planets 64 of the first planetary gear assembly 60 are free to

-8-

rotate. The first stage planet carrier 66 shown in Figure 6A is also free to rotate, and serves as the sun input gear for the second planetary gear assembly 70.

[0031] The rotation of the second stage ring gear 72 shown in Figures 5A and 5B is controlled by a release latch 80 that engages the teeth 74 provided on the outer periphery of the second stage ring gear 72 as shown in Figures 5A and 5B. In this regard, the release latch 80 is biased by a bias spring 82 towards the second stage ring gear 72 as clearly shown Figures 5A to 7. The second stage planets 76 are also free to rotate, the axles of the second stage planets 76 being fixed to the cable drum 42 to control the rotation thereof. In this regard, the cable drum 42 effectively serves as the planet carrier and the output gear of the second planetary gear assembly 70.

[0032] Thus, the cable lift and release mechanism 30 of the illustrated embodiment of Figures 2 to 7 described above utilizes the first planetary gear assembly 60 to achieve the desired gear reduction, so that the torque of the motor 50 can be substantially increased. In addition, the second planetary gear assembly 70 is also used to rotate the cable drum 42 to wind up the cable 36 thereon, to thereby lift the spring carriage 32 and compress the spring 34, as well as to allow the release of the cable 36 so that the energy stored in the spring 34 can be released to drive a fastener.

[0033] The detailed operation of the cable lift and release mechanism 30 of the above described embodiment is discussed herein below with reference to Figures 2 to 7. To compress the spring 34, the release latch 80 is engaged to a tooth 74 of the second stage ring gear 72 as shown in Figures 5A and 5B, thereby preventing the second stage ring gear 72 from rotating. With the position of the second stage ring gear 72 fixed, the driven gear of the second planetary gear assembly 70 is the cable drum 42. The torque of the motor 50 acting through the gear reduction provided by the first planetary gear assembly 60, turns the second stage sun gear clockwise, and resultantly, rotates the cable drum 42 clockwise in the illustration of the cable lift and release mechanism 30 shown Figures 2 and 4. This clockwise rotation of the cable drum 42 wraps the

-9-

cable 36 around the cable drum 42, thereby lifting the spring carriage 32, and compressing the spring 34 to store energy therein.

[0034] At a predetermined stroke length, the spring carriage 32 engages one end of the release latch 80 opposite to the end that engages the teeth 74 of the second stage ring gear 72 as most clearly shown in Figure 7, thereby rotating the release latch 80 out of engagement with second stage ring gear 72. Thus, the second stage ring gear 72, and the cable drum 42, are free to rotate in the gear housing 56, since they are no longer coupled to the motor 50. This allows the energy stored in the compressed spring 34 to be freely released as the spring carriage 32 is instantaneously accelerated by the spring 34 as the spring 34 uncompresses, resulting in spinning the cable drum 42 in a counter clockwise direction (ccw) in the illustration of Figure 4. The fastener driver connected to the spring carriage 32 engages a fastener provided from the magazine 16, and drives the fastener into a workpiece using the energy from the spring 34 as it uncompresses.

[0035] At the end of the drive stroke when the spring 34 has substantially uncompressed, further displacement of the spring carriage 32 is stopped by the bumper 39. However, the cable drum 42 may still have significant rotational velocity. Correspondingly, this rotation of the cable drum 42 is stopped by a drum stop pin 44 that engages the bumper 46, as previously noted.

[0036] It should be understood that in accordance with the illustrated embodiment of the cable lift and release mechanism 30, the motor 50 continues to drive the second stage sun gear during the release of the spring 34, which has the effect of trying to rotate the cable drum 42 in the clockwise direction opposing the force of the spring 34 that pulls on the cable 36. However, because the second stage ring gear 72 is free to rotate, the cable drum 42 that functions as the planet carrier, and the planets 76 of the second planetary gear assembly 70, are independent from the sun gear and do not impede the uncompressing spring 34 to any appreciable degree. Thus, the sun gear's rotation has the effect of

-10-

increasing the planets' rotational velocity above the velocity attributable to the counter-clockwise motion of the planet carrier, i.e. the cable drum 42.

[0037] In the illustrated embodiment of the cable lift and release mechanism 30, when the release latch 80 is disengaged from the second stage ring gear 72, the release latch 80 cannot re-engage the teeth 74 of the second stage ring gear 72 until the ring gear has rotated approximately 270 degrees past that re-engagement space 77 (i.e. the portion of the ring gear 72 that is not provided with teeth 74) most clearly shown in Figure 5A, and a tooth 74 is aligned with the latch 80. Once aligned, the bias spring 82 causes the release latch 80 to re-engage with the tooth 74 on the second stage ring gear 72. When the release latch 80 re-engages the tooth 74 on the ring gear 72, the rotational position of the ring gear 72 is again fixed, and the cable drum 42 functions as the output (driven) gear, i.e. a planet carrier.

[0038] The second stage ring gear's 72 natural rotation when released is in the counter-clockwise direction in the illustration shown in Figures 2 and 4 by the virtue of the spring carriage 32 pulling on the cable 36. Equation (1) below describes the relationship between the cable drum 42 and sun gear velocities. Counter-clockwise rotation is a negative value, while clockwise rotation is a positive value, N representing the number of teeth of the specified gear.

$$\omega_{ring} = -\frac{N_{sun}}{N_{ring}} \cdot \omega_{sun} + \omega_{Drum} \left(1 + \frac{N_{sun}}{N_{ring}} \right) \quad (1)$$

[0039] During the release, the cable drum's 42 rotation is counter-clockwise (negative), and acts to increase the velocity of the second stage ring gear 72 in the counter-clockwise direction. When the cable drum 42 stops at the end of the drive stroke, the rotational position of the cable drum 42 is essentially fixed by the drum stop pin 44 and the bumper 46 in the counter-clockwise direction, and restrained by the preload force of the spring 34 in the clockwise direction in the illustration shown in Figures 2 and 4. The cable drum's 42 velocity is zero so

-11-

the second stage ring gear 72 is then driven in the counter-clockwise direction in Figures 1 and 2 by the motor 50.

[0040] Of course, the diameter of the cable drum 42 and the gear ratios of the planetary gear assemblies should be implemented to ensure proper positioning of the cable drum 42, and proper positioning and timing of the second stage ring gear 72 to ensure adequate time for the latch 80 to re-engage. During the drive stroke when the energy stored in the spring 34 is released, the rotational inertia of the cable drum 42 and the second planetary gear assembly 70 may reduce the drive energy. However, such loss can be minimized by carefully implementing the cable drum 42, the sheaves 40, and the second stage planets 76, to have low moments of rotational inertia.

[0041] The operation of fastener driving device 10 and the cable lift and release mechanism 30 described above, may be controlled by a controller (not shown) for the fastener driving device 10 which is in communication with the motor 50. The controller may be implemented such that upon receiving a signal from the trigger 22 and/or a contact trip assembly for bump actuation (not shown) as described below, the controller signals the motor 50 to energize for a predetermined amount of time to operate the cable lift and release mechanism 30 in the manner described above to compress the spring 34 and initiate a drive stroke.

[0042] In the above regard, it should be understood that the fastener driving device 10 may be implemented with a contact trip assembly (not shown) to allow for bump actuation. The contact trip assembly is commonly found on pneumatic fastener driving devices, and is described, for example, in U.S. Patent No. 6,186,386, which is incorporated herein by reference. Thus, the fastener driving device 10 is preferably implemented for operation in the trigger 22 and/or bump actuation modes. Of course, the contact trip assembly may be implemented differently than as described in the '386 patent in other embodiments of the present invention.

-12-

[0043] After completion of the drive stroke, the fastener driving device 10 is preferably implemented to signal the motor 50 to energize for a short time so that the cable drum 42 is rotated a predetermined amount to partially pre-compress the spring 34, for example, 70-95% of compression required for a full drive stroke, prior to initiating the drive sequence. Thus the motor operates, or is controlled, for example, by a controller, to rotate the drum and pull the cable to partially compress the spring, and to stop compression of the spring at partial compression, and to continue to compress the spring further upon initiation of a subsequent drive sequence. Such partial, pre-compressing of the spring 34 is advantageous in that it reduces the amount of time needed to fully compress the spring 34 for actuation during the subsequent drive stroke, especially when the fastener driving device 10 is utilized in a bump actuation mode. Preferably, the fastener driver is implemented such that it does not engage the head of the fastener in this pre-compressed position so that if there is a mechanical failure in the fastener driving device 10 which results in the spring 34 freely releasing its energy, no fastener is driven. Also, clutch 54 operates to prevent the system from back driving the motor in the pre-compressed position. Moreover, in such an implementation where a controller is provided, the controller is further preferably programmed so that after a predetermined amount of time in which the fastener driving device 10 has not been used, the spring carriage 32 is allowed to return to a position in which there is no substantial pre-compressing of the spring 34.

[0044] The fastener driving device 10 of the present invention with the cable lift and release mechanism 30 of the illustrated embodiment as described above has the advantage of high overall mechanical efficiency for compressing the spring 34 to store energy therein, when compared with other spring compression mechanisms. Energy consuming sliding friction is substantially eliminated in compressing the spring 34 within the fastener driving device 10, and the inefficiencies that remain such as gear and bearing losses, other than a very small amount of cable stretch, are common to other spring compression

-13-

mechanisms. Such efficiency minimizes the required power so that in portable implementations of the fastener driving device 10, the source of power, such as the battery 24, provides higher number of operational cycles before requiring a recharge than less efficient mechanisms.

[0045] Because the energy that is used to drive the fastener during the drive stroke is temporarily stored in the spring 34, the power and drive time of the fastener driving device 10 is a function of, among other things, the design of the spring 34 itself. Correspondingly, in accordance with the preferred embodiment of the present invention, the spring 34 is made of a composite material in order to derive enhanced efficiency and power, in comparison with prior art metal springs. The spring 140 is preferably made of fiberglass and epoxy, and most preferably, the fibers are continuous through the spring. In particular, the fiberglass may be Owens Corning SE 1200 Type 30 and/or Owens Corning 346 Type 30, 600 or 1200 Tex (grams/kilometer line weight), 600 Tex being preferred. The epoxy may be Huntsman: Araldite LY3505 hardeners XB3403 / XB3404/ XB3405 or Huntsman: Araldite LY556 hardener 22962. Various common additives may also be used to improve wetout, preclude aeration, and improve processing. Fiberglass and epoxy is a very good material because of its blend of economics and performance, including modulus of elasticity and tensile strength characteristics. Of course, other fibers and resins may be utilized for the spring in other embodiments of the present invention. For instance, carbon, aramid, boron, basal, and synthetic spider silk, etc. may be used, or in still other embodiments, combinations of fiber materials and other resins may be used, such as polyester, vinyl ester, urethanes, as well as thermoplastic resins, ABS, nylon, polypropylene, peek, etc. Depending on the particular usage parameters, a spring made from such materials may achieve better performance than the fiberglass composite described. However, in view of the blend of economics and performance, the preferred implementation of the spring utilizes fiberglass composite as described above.

-14-

[0046] Such glass epoxy and carbon epoxy composite springs can be manufactured in any appropriate manner and may be available from composite spring manufacturers such as Liteflex, LLC. of Englewood, OH. In accordance with one preferred implementation, a fiberglass core is assembled with multiple fibers being either twisted, braided or bundled together in line and are wetted out individually before bundling or wetted as a bundled assembly. Of course, in other embodiments, composite springs that do not include a core may be used as well. The size of the core can be varied depending on the stiffness of the wire desired and/or the time desired to complete the layup of the wire. The glass epoxy composite spring of the above noted embodiment may be manufactured with core sizes in the range 0.080" to 0.200" in diameter. Wires with smaller cores have been found to yield better fatigue life results. Of course, in other embodiments, the spring may be made of metal instead.

[0047] In such an embodiment when the spring 34 is made of a composite material, the fastener driving device 10 is preferably implemented so that there is a slight spring preload in the home position, even after driving of the fastener, so that the spring is always slightly compressed. Such spring preload improves composite spring life by reducing coil surge and resulting stress reversal, thereby enhancing to the functional benefits of using a composite spring.

[0048] The above discussion sets forth a composite spring fastener driving device in accordance with the present invention. Of course, the fastener driving device is not limited thereto, and the fastener driving device may be implemented using springs made of different materials, although less preferred than composite materials for the reasons set forth above. Moreover, various different composite materials may be used as described above, including glass epoxy and carbon epoxy. In addition, the spring need not be a coil spring as shown and described, but can be any appropriate type of structural spring that is made of any appropriate materials. Correspondingly, the term "spring" as used herein, should be broadly understood to encompass any device that allows storage and release of strain energy, for example, any structural spring, such as a

-15-

coil, Belleville type, leaf, torsion, or sulcated spring. Moreover, the term “spring” as used herein, should be broadly understood to encompass any device that allows storage and release of energy from a volume under pressure that expands to do work, such as a gas spring. However, use of coil springs, and especially such coil springs made of a composite material, allows realization of various advantages to the fastener driving device as discussed hereinabove.

[0049] Therefore, in view of the above, it should now be evident to one of ordinary skill in the art, that the present invention provides a fastener driving device that utilizes a spring to drive a fastener into a workpiece, the fastener driving device including a mechanism for rapidly compressing and releasing the spring. It should also be evident that the fastener driving device of the present invention is mechanically efficient to thereby allow high number operational cycles in those implementations where the fastener driving tool is portable.

[0050] While various embodiments in accordance with the present invention have been shown and described, it is understood that the invention is not limited thereto. The present invention may be changed, modified and further applied by those skilled in the art. Therefore, this invention is not limited to the detail shown and described previously, but also includes all such changes and modifications.

-16-

We claim:

1. A fastener driving device, comprising:
a fastener driver displaceable to drive a fastener;
a structural spring adapted to move the fastener driver through a drive stroke;
and
a cable for compressing the structural spring and moving the fastener driver through a retraction stroke.
2. The fastener driving device of claim 1, further including a drum connected to the cable and a motor adapted to rotate the drum.
3. The fastener driving device of claim 1, wherein said drum is operable to rotate less than 360 degrees to achieve a full retraction stroke.
4. The fastener driving device of claim 2, further including a spring carriage connected to the cable and at least partially receiving the structural spring.
5. The fastener driving device of claim 2, further including a clutch and at least one planetary gear assembly connecting said drum to said motor.
6. The fastener driving device of claim 5, wherein said at least one planetary gear assembly includes a first planetary gear assembly and a second planetary gear assembly.
7. The fastener driving device of claim 4, further including a release latch positioned for engagement by said spring carriage to allow rotation of the drum and movement of the structural spring and fastener driver through the drive stroke.

-17-

8. The fastener driving device of claim 2, wherein the motor is operable to rotate said drum and pull said cable to partially compress said structural spring, to stop compression of said structural spring at partial compression, and to continue to compress said structural spring further upon initiation of a subsequent drive sequence.

9. The fastener driving device of claim 8, wherein partial compression of said structural spring is at least 70% of compression required for a full drive stroke.

10. The fastener driving device of claim 1, wherein the structural spring is a coil spring formed of a composite material including at least one of glass, carbon, aramid, boron, basal, and synthetic spider silk fiber.

11. The fastener driving device of claim 10, wherein the composite material includes at least one of epoxy, polyester, vinyl ester, urethane, a thermoplastic resin, ABS, nylon, polypropylene and peek.

12. A fastener driving device, comprising:
a fastener driver displaceable to drive a fastener;
a spring adapted to move the fastener driver through a drive stroke;
a cable for compressing the spring in a return stroke; and
a drum rotatably mounted to pull the cable to compress the spring in a retraction stroke.

13. The fastener driving device of claim 12, further including a motor adapted to rotate the drum, said drum being connected to the cable.

-18-

14. The fastener driving device of claim 12, wherein said drum is operable to rotate less than 360 degrees to achieve a full retraction stroke.

15. The fastener driving device of claim 12, wherein said spring is a structural spring, further including a spring carriage connected to the cable and at least partially receiving the structural spring.

16. The fastener driving device of claim 13, further including a clutch, a first planetary gear assembly, and a second planetary gear assembly, connecting the motor to the drum.

17. The fastener driving device of claim 13, wherein the motor is operable to rotate said drum and pull said cable to partially compress said spring, to stop compression of said spring at partial compression, and to continue to compress said spring further upon initiation of a subsequent drive sequence.

18. The fastener driving device of claim 17, wherein partial compression of said spring is at least 70% of compression required for a full drive stroke.

19. The fastener driving device of claim 12, wherein the spring is a structural spring formed of a composite material including at least one of glass, carbon, aramid, boron, basal, and synthetic spider silk fiber.

20. The fastener driving device of claim 19, wherein the composite material further includes at least one of epoxy, polyester, vinyl ester, urethane, a thermoplastic resin, ABS, nylon, polypropylene and peek.

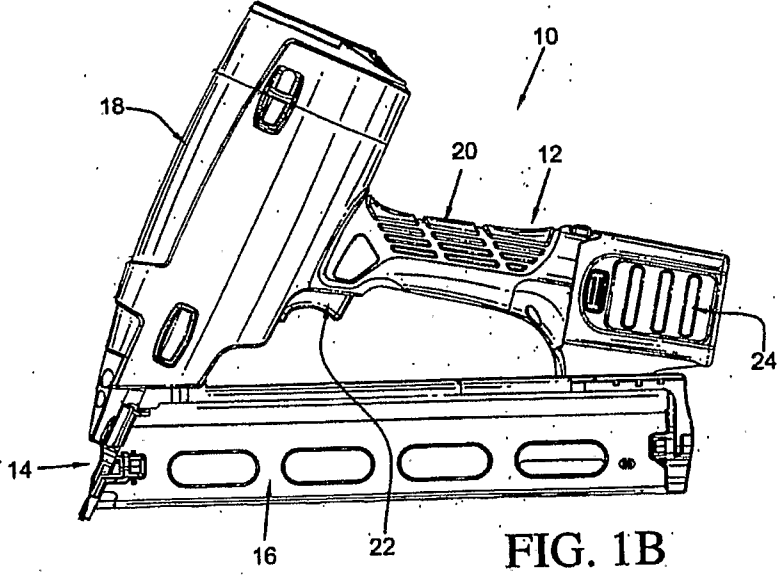
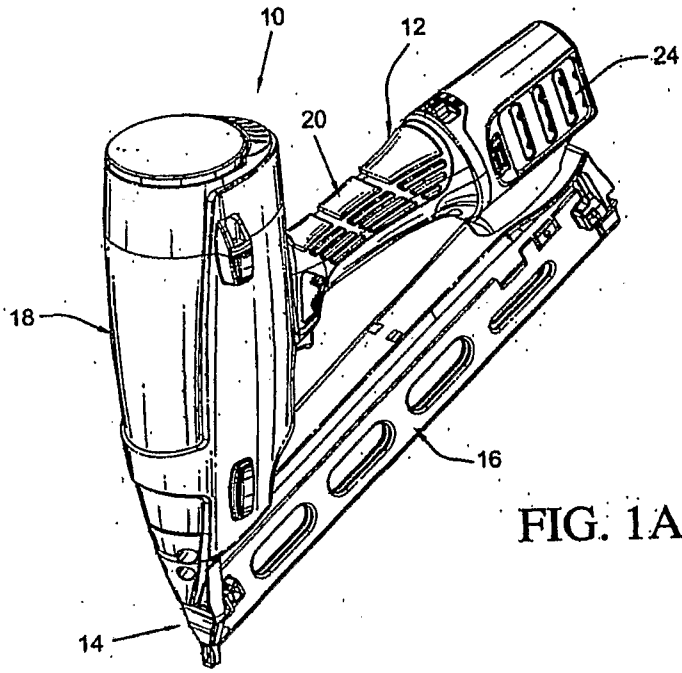

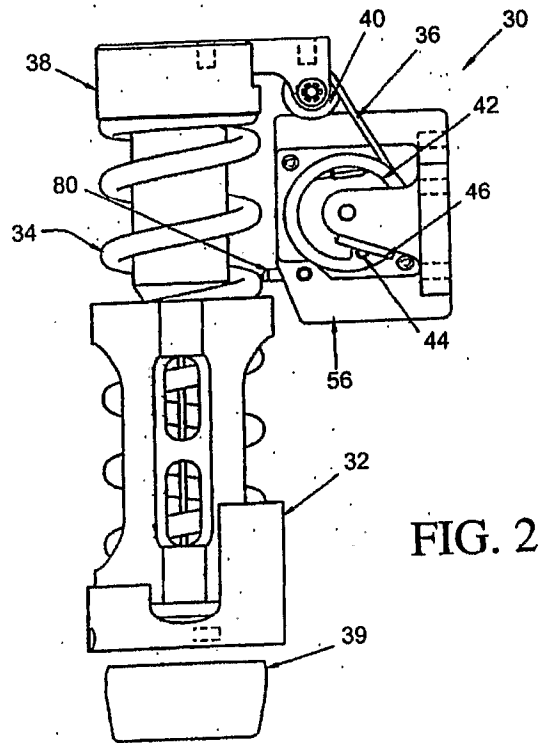
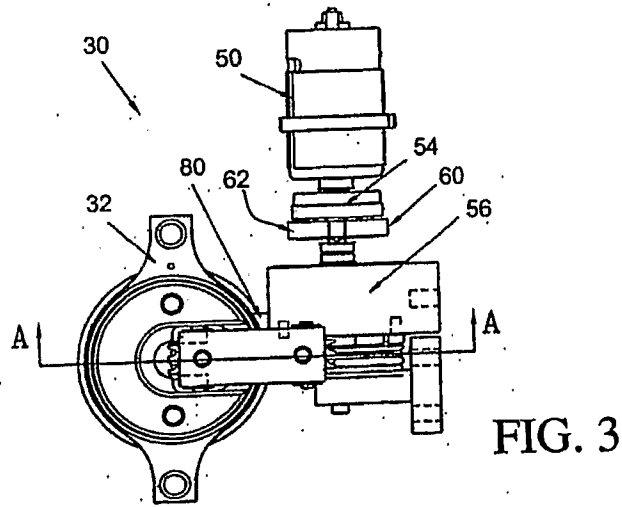

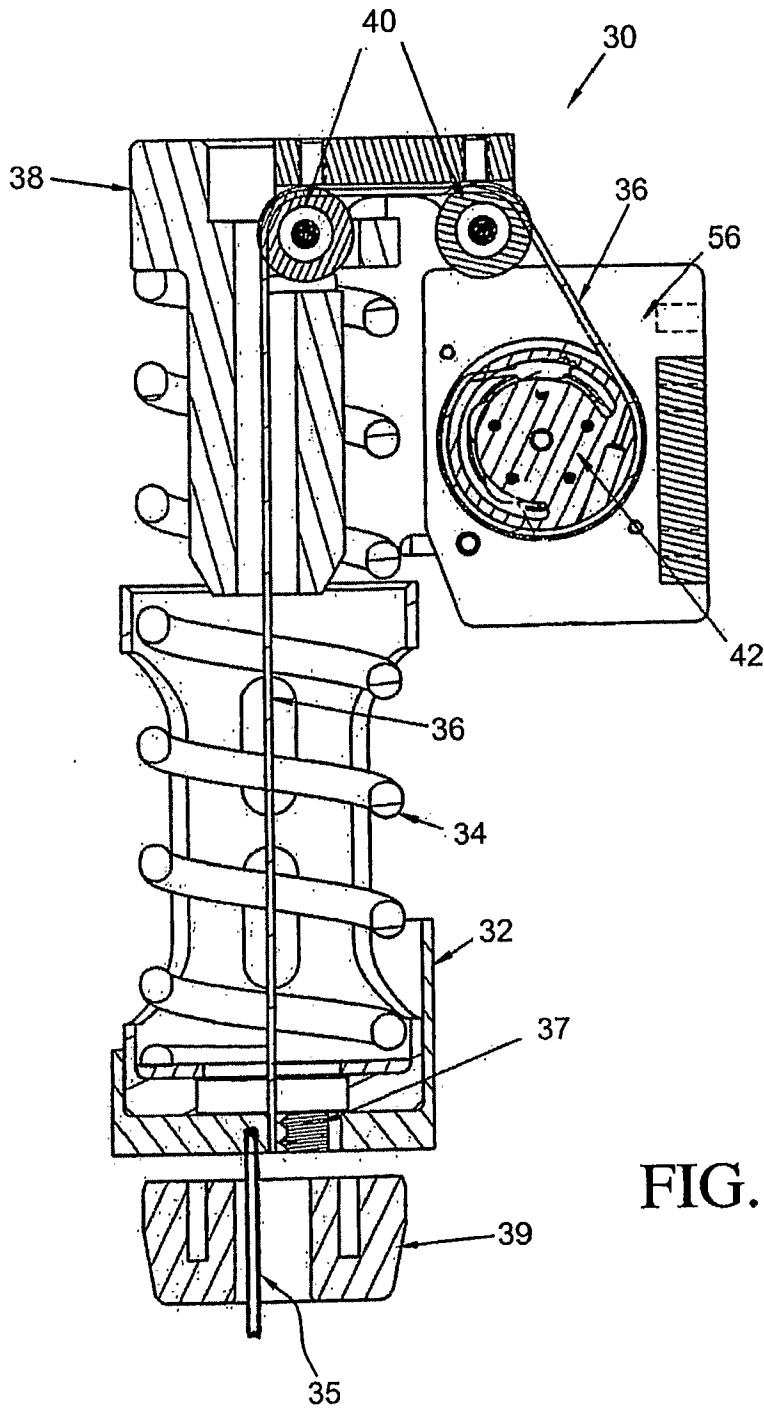

FIG. 4

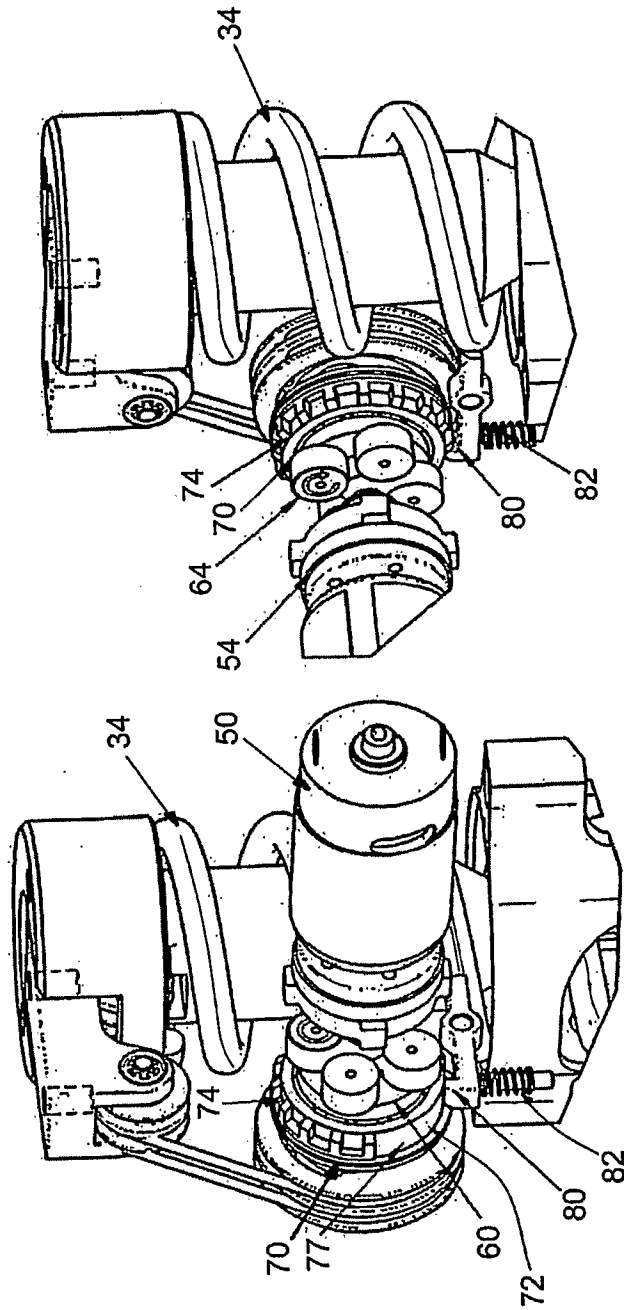

FIG. 5B

FIG. 5A

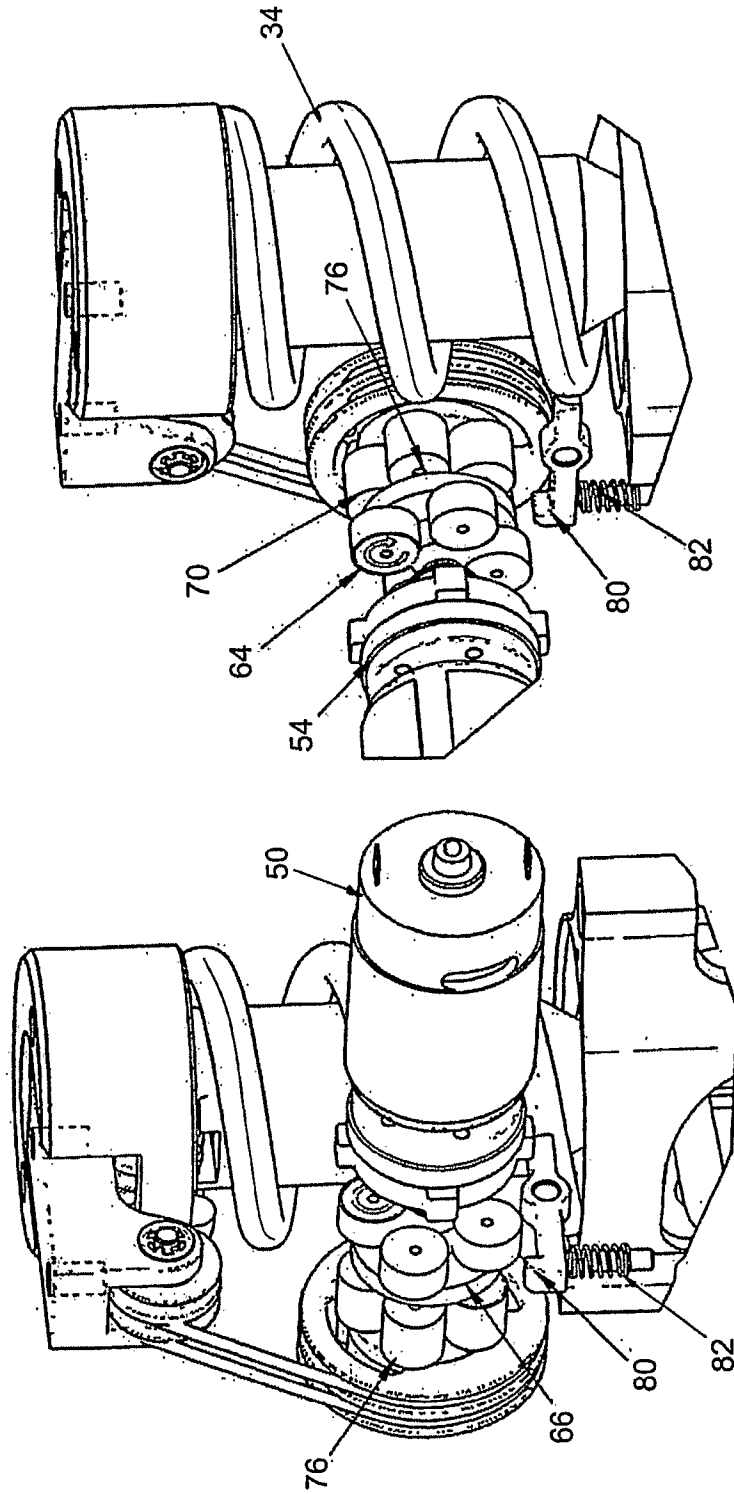

FIG. 6B

FIG. 6A

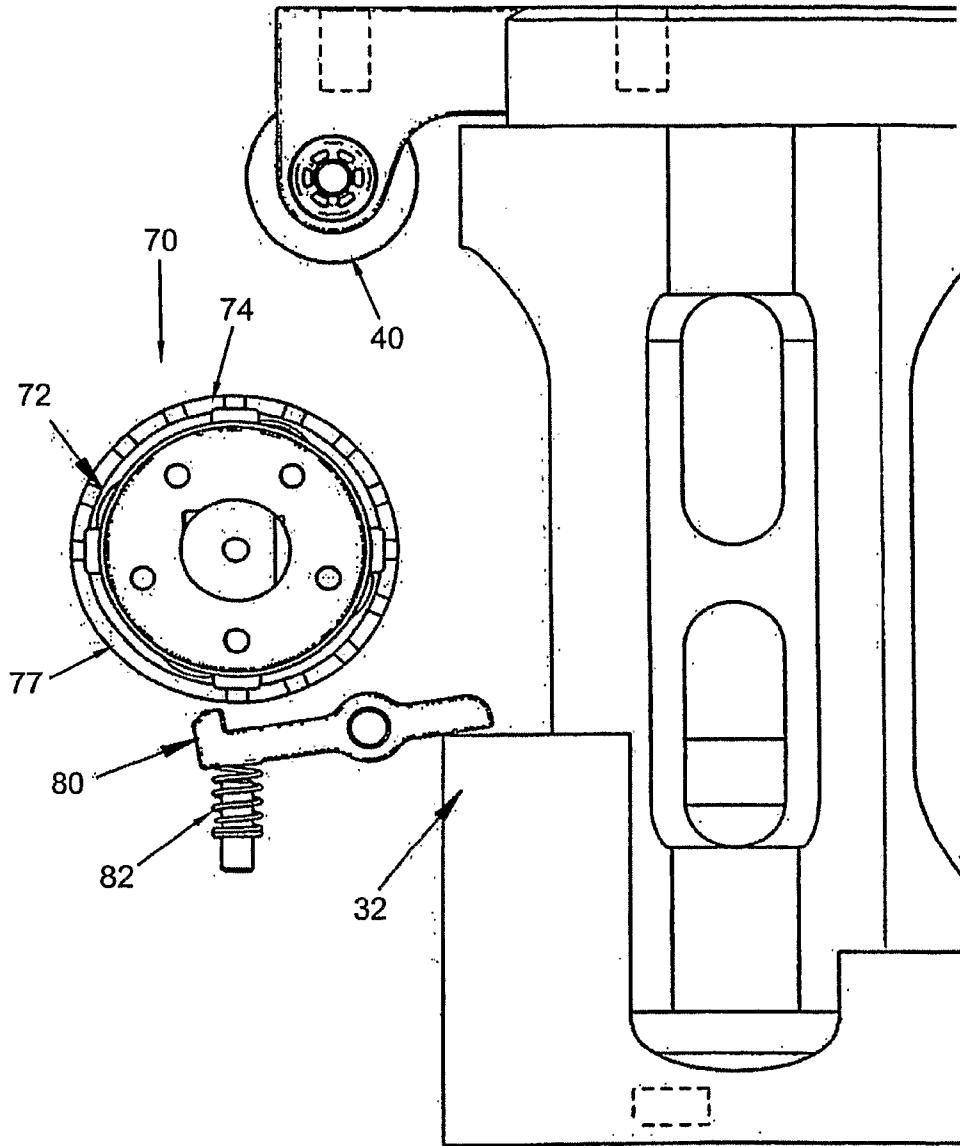

FIG. 7