

(19) World Intellectual Property Organization  
International Bureau



(43) International Publication Date  
20 December 2001 (20.12.2001)

PCT

(10) International Publication Number  
WO 01/96340 A1

- (51) International Patent Classification<sup>7</sup>: C07D 475/14, A61L 2/00, 2/08, 2/10
- (74) Agent: O'CONNOR, Edna, M.; Gambro Patent Dept., 10810 W. Collins Avenue, Lakewood, CO 80215-4439 (US).
- (21) International Application Number: PCT/US01/18752
- (22) International Filing Date: 8 June 2001 (08.06.2001)
- (25) Filing Language: English
- (26) Publication Language: English
- (30) Priority Data: 09/596,429 15 June 2000 (15.06.2000) US
- (81) Designated States (*national*): AE, AG, AL, AM, AT, AU, AZ, BA, BB, BG, BR, BY, BZ, CA, CH, CN, CR, CU, CZ, DE, DK, DM, DZ, EE, ES, FI, GB, GD, GE, GH, GM, HR, HU, ID, IL, IN, IS, JP, KE, KG, KP, KR, KZ, LC, LK, LR, LS, LT, LU, LV, MA, MD, MG, MK, MN, MW, MX, MZ, NO, NZ, PL, PT, RO, RU, SD, SE, SG, SI, SK, SL, TJ, TM, TR, TT, TZ, UA, UG, UZ, VN, YU, ZA, ZW.
- (84) Designated States (*regional*): ARIPO patent (GH, GM, KE, LS, MW, MZ, SD, SL, SZ, TZ, UG, ZW), Eurasian patent (AM, AZ, BY, KG, KZ, MD, RU, TJ, TM), European patent (AT, BE, CH, CY, DE, DK, ES, FI, FR, GB, GR, IE, IT, LU, MC, NL, PT, SE, TR), OAPI patent (BF, BJ, CF, CG, CI, CM, GA, GN, GW, ML, MR, NE, SN, TD, TG).
- (71) Applicant: GAMBRO, INC. [US/US]; Patent Dept., 10810 W. Collins Avenue, Lakewood, CO 80215-4439 (US).
- (72) Inventors: GOODRICH, Raymond, Paul, Jr.; 3500 E. Kentucky Avenue, Denver, CO 80209 (US). HLAVINKA, Dennis; 7365 N. Salvia Court, Arvada, CO 80007 (US).
- Published: — with international search report

[Continued on next page]

(54) Title: METHOD FOR INACTIVATION OF MICROORGANISMS USING PHOTOSENSITIZERS

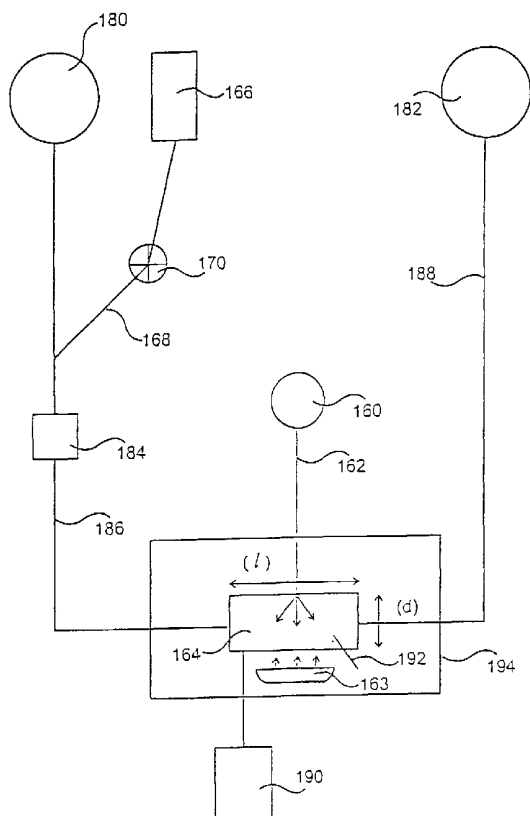

(57) Abstract: Methods and apparatuses for treating fluids to inactivate microorganisms which may be present therein, said fluid containing one or more components selected from the group consisting of protein, blood and blood constituents are provided. The methods comprise adjusting the percentage of plasma in said fluid to a desired value; mixing an inactivation-effective, substantially non-toxic amount of an endogenous photosensitizer or endogenously-based derivative photosensitizer to said fluid; exposing said fluid to photoradiation of sufficient wavelength and energy to activate the photosensitizer, whereby said microorganisms are inactivated.



WO 01/96340 A1



— *before the expiration of the time limit for amending the claims and to be republished in the event of receipt of amendments*

*For two-letter codes and other abbreviations, refer to the "Guidance Notes on Codes and Abbreviations" appearing at the beginning of each regular issue of the PCT Gazette.*

## 5 METHOD FOR INACTIVATION OF MICROORGANISMS USING PHOTSENSITIZERS

## BACKGROUND OF THE INVENTION

0 Contamination of blood supplies with infectious microorganisms such as HIV,  
hepatitis and other viruses and bacteria presents a serious health hazard for those who must  
receive transfusions of whole blood or administration of various blood components such as  
platelets, red cells, blood plasma, Factor VIII, plasminogen, fibronectin, anti-thrombin III,  
cryoprecipitate, human plasma protein fraction, albumin, immune serum globulin,  
prothrombin complex, plasma growth hormones, and other components isolated from blood.  
5 Blood screening procedures may miss contaminants, and sterilization procedures which do  
not damage cellular blood components but effectively inactivate all infectious viruses and  
other microorganisms have not heretofore been available.

10 In addition, a system that uses the same chemistry to inactivate microorganisms in  
different fluids, for example separate blood components, is desired for many reasons,  
including ease of use in a blood bank setting. This type of system has not heretofore been  
available. It is also desired that the inactivation treatment be easily implemented in a blood  
bank setting, and produce inactivation in a short period of time.

15 Some methods of decontaminating blood have been described. Solvent detergent  
methods of blood component decontamination work by dissolving phospholipid membranes  
surrounding viruses such as HIV, and do not damage protein components of blood; however,  
if blood cells are present, such methods cannot be used because of damage to cell  
membranes.

20 The use of photosensitizers, compounds which absorb light of a defined wavelength  
and transfer the absorbed energy to an energy acceptor, has been proposed for blood  
component sterilization. For example, European Patent application 196,515 published  
October 8, 1986, suggests the use of non-endogenous photosensitizers such as porphyrins,  
psoralens, acridine, toluidines, flavine (acriflavine hydrochloride), phenothiazine derivatives,  
25 and dyes such as neutral red and methylene blue, as blood additives. Protoporphyrin, which  
occurs naturally within the body, can be metabolized to form a photosensitizer; however, its  
usefulness is limited in that it degrades desired biological activities of proteins.  
Chlorpromazine is also exemplified as one such photosensitizer; however its usefulness is

limited by the fact that it should be removed from any fluid administered to a patient after the decontamination procedure because it has a sedative effect.

5 Goodrich, R.P., et al. (1997), "The Design and Development of Selective,  
Photoactivated Drugs for Sterilization of Blood Products," *Drugs of the Future* 22:159-171  
provides a review of some photosensitizers including psoralens, and some of the issues of  
importance in choosing photosensitizers for decontamination of blood products. The use of  
texaphyrins for DNA photocleavage is described in U.S. Patent Nos. 5,607,924 issued March  
4, 1997 and 5,714,328 issued February 3, 1998 to Magda et al. The use of sapphyrins for  
10 viral deactivation is described in U.S. Patent No. 5,041,078 issued August 20, 1991 to  
Matthews, et al. Inactivation of extracellular enveloped viruses in blood and blood  
components by Phenthiazin-5-ium dyes plus light is described in U.S. Patent No. 5,545,516  
issued August 13, 1996 to Wagner. The use of porphyrins, hematoporphyrins, and  
merocyanine dyes as photosensitizing agents for eradicating infectious contaminants such as  
15 viruses and protozoa from body tissues such as body fluids is disclosed in U.S. Patent  
4,915,683 issued April 10, 1990 and related U.S. Patent No. 5,304,113 issued April 19, 1994  
to Sieber et al. The mechanism of action of such photosensitizers is described as involving  
preferential binding to domains in lipid bilayers, e.g. on enveloped viruses and some virus-  
infected cells. Photoexcitation of membrane-bound agent molecules leads to the formation of  
20 reactive oxygen species such as singlet oxygen which causes lipid peroxidation. A problem  
with the use of such photosensitizers is that they attack cell membranes of desirable  
components of fluids to be decontaminated, such as red blood cells, and the singlet oxygen  
also attacks desired protein components of fluids being treated. U.S. Patent 4,727,027 issued  
February 23, 1988 to Wiesehahn, G.P., et al. discloses the use of furocoumarins including  
25 psoralen and derivatives for decontamination of blood and blood products, but teaches that  
steps must be taken to reduce the availability of dissolved oxygen and other reactive species  
in order to inhibit denaturation of biologically active proteins. Photoinactivation of viral and  
bacterial blood contaminants using halogenated coumarins is described in U.S. Patent  
5,516,629 issued May 14, 1996 to Park, et al. U.S. Patent 5,587,490 issued December 24,  
30 1996 to Goodrich Jr., R.P., et al. and U.S. Patent No. 5,418,130 to Platz, et al. disclose the  
use of substituted psoralens for inactivation of viral and bacterial blood contaminants. The  
latter patent also teaches the necessity of controlling free radical damage to other blood  
components. U.S. Patent 5,654,443 issued August 5, 1997 to Wollowitz et al. teaches new  
psoralen compositions used for photodecontamination of blood. U.S. Patent 5,709,991 issued  
35 January 20, 1998 to Lin et al. teaches the use of psoralen for photodecontamination of platelet  
preparations and removal of psoralen afterward. U.S. Patent 5,120,649 issued June 9, 1992  
and related U.S. Patent 5,232,844 issued August 3, 1993 to Horowitz, et al., also disclose the

need for the use of “quenchers” in combination with photosensitizers which attack lipid membranes, and U.S. Patent 5,360,734 issued November 1, 1994 to Chapman et al. also addresses the problem of prevention of damage to other blood components.

5           Photosensitizers which attack nucleic acids are known to the art. U.S. Patent 5,342,752 issued August 30, 1994 to Platz et al. discloses the use of compounds based on acridine dyes to reduce parasitic contamination in blood matter comprising red blood cells, platelets, and blood plasma protein fractions. These materials, although of fairly low toxicity, do have some toxicity e.g. to red blood cells. This patent fails to disclose an apparatus for  
10       decontaminating blood on a flow-through basis. U.S. Patent No. 5,798,238 to Goodrich, Jr., et al., discloses the use of quinolone and quinolone compounds for inactivation of viral and bacterial contaminants.

          Binding of DNA with photoactive agents has been exploited in processes to reduce  
15       lymphocytic populations in blood as taught in U.S. Patent No. 4,612,007 issued September 16, 1986 and related U.S. Patent No. 4,683,889 issued August 4, 1987 to Edelson.

          Riboflavin (7,8-dimethyl-10-ribityl isoalloxazine) has been reported to attack nucleic acids. Photoalteration of nucleic acid in the presence of riboflavin is discussed in Tsugita, A,  
20       et al. (1965), “Photosensitized inactivation of ribonucleic acids in the presence of riboflavin,” *Biochimica et Biophysica Acta* 103:360-363; and Speck, W.T. et al. (1976), “Further Observations on the Photooxidation of DNA in the Presence of Riboflavin,” *Biochimica et Biophysica Acta* 435:39-44. Binding of lumiflavin (7,8,10-trimethylisoalloxazine) to DNA is discussed in Kuratomi, K., et al. (1977), “Studies on the Interactions between DNA and  
25       Flavins,” *Biochimica et Biophysica Acta* 476:207-217. Hoffmann, M.E., et al. (1979), “DNA Strand Breaks in Mammalian Cells Exposed to Light in the Presence of Riboflavin and Tryptophan,” *Photochemistry and Photobiology* 29:299-303 describes the use of riboflavin and tryptophan to induce breaks in DNA of mammalian cells after exposure to visible fluorescent light or near-ultraviolet light. The article states that these effects did not  
30       occur if either riboflavin or tryptophan was omitted from the medium. DNA strand breaks upon exposure to proflavine and light are reported in Piette, J. et al. (1979), “Production of Breaks in Single- and Double-Stranded Forms of Bacteriophage  $\Phi$ X174 DNA by Proflavine and Light Treatment,” *Photochemistry and Photobiology* 30:369-378, and alteration of guanine residues during proflavine-mediated photosensitization of DNA is discussed in  
35       Piette, J., et al. (1981), “Alteration of Guanine Residues during Proflavine Mediated Photosensitization of DNA,” *Photochemistry and Photobiology* 33:325-333.

J. Cadet, et al. (1983), "Mechanisms and Products of Photosensitized Degradation of Nucleic Acids and Related Model Compounds," Israel J. Chem. 23:420-429, discusses the mechanism of action by production of singlet oxygen of rose bengal, methylene blue, thionine and other dyes, compared with mechanisms not involving production of singlet oxygen by which nucleic acid attack by flavin or pteron derivatives proceeds. Riboflavin is exemplified in this disclosure as having the ability to degrade nucleic acids. Korycka-Dahl, M., et al. (1980), "Photodegradation of DNA with Fluorescent Light in the Presence of Riboflavin, and Photoprotection by Flavin Triplet-State Quenchers," Biochimica et Biophysica Acta 610:229-234 also discloses that active oxygen species are not directly involved in DNA scission by riboflavin. Peak, J.G., et al. (1984), "DNA Breakage Caused by 334-nm Ultraviolet Light is Enhanced by Naturally Occurring Nucleic Acid Components and Nucleotide Coenzymes," Photochemistry and Photobiology 39:713-716 further explores the mechanism of action of riboflavin and other photosensitizers. However, no suggestion is made that such photosensitizers be used for decontamination of medical fluids.

Apparatuses for decontamination of blood have been described in U.S. Patent No. 5,290,221 issued March 1, 1994 to Wolfe, Jr., et al. and U.S. Patent No. 5,536,238 issued July 16, 1996 to Bischof. U.S. Patent No. 5,290,221 discloses the irradiation of fluid in a relatively narrow, arcuate gap. U.S. Patent 5,536,238 discloses devices utilizing optical fibers extending into a filtration medium. Both patents recommend as photosensitizers benzoporphyrin derivatives which have an affinity for cell walls.

U.S. Patent No. 5,527,704 issued June 18, 1996 to Wolf, Jr., et al. discusses an apparatus to inactivate viruses contained in a body fluid in a container using methylene blue as a photosensitizer. The body fluid is maintained in a static state within the container during irradiation. U.S. Patent No. 5,868,695 issued February 9, 1999 to Wolf, Jr. et al. discloses a system where blood containing a photoactive material is directed in a predetermined flow path such as a serpentine in a narrow gap in a treatment chamber. PCT published application No. WO 96/06647 discloses irradiating a product in an array of light emitting diodes surrounded by a fluid used to prevent overheating of the diodes.

U. S. Patents 5,360,734 issued November 1, 1994 to Chapman et al. and 5,597,722 issued January 28, 1997 to Chapman et al. discuss treating a blood component containing red blood cells and plasma proteins with a photoactive agent such as pyrrolic macrocycles, psoralens or methylene blue after removing a portion of the plasma proteins. The treated blood component is required to be prevented from contacting plasma proteins for a period of time (three to eighteen hours) after treatment to prevent bonding of the treated cells with IgG

proteins in the plasma. The presence of IgG has various negative effects, including interference with commonly used serological and diagnostic testing procedures.

5 United States Patent Application 09/119,666 and continuation-in-part Application 09/357,188, both hereby incorporated by reference to the extent not inconsistent with the disclosure herein, disclose the use of endogenous and endogenously-based photosensitizers including 7,8-dimethyl-10-ribityl isoalloxazine to inactivate microorganisms in a variety of fluids, including blood and blood products, but do not disclose removing plasma from the fluids.

10 U. S. Patent Application 09/420,652 hereby incorporated by reference to the extent not inconsistent with the disclosure herein, discloses isoalloxazine derivatives to neutralize microorganisms, but does not disclose removing plasma from the fluids.

#### 15 BRIEF SUMMARY OF THE INVENTION

Methods and apparatuses are provided for treating a fluid to inactivate at least some of the microorganisms and/or white cells that may be present therein or thereon, said fluid containing one or more components selected from the group consisting of protein, (e.g. biologically active protein such as a therapeutic protein), blood and blood constituents. One such method comprises:

- 20
- (a) adjusting the percentage of plasma in said fluid to a desired value;
  - (b) mixing an inactivation-effective, substantially non-toxic amount of an endogenous photosensitizer or endogenously-based derivative photosensitizer with said fluid; and
  - 25 (c) exposing said fluid to photoradiation of sufficient wavelength and energy to activate the photosensitizer, whereby said microorganisms are inactivated.

30 It has been discovered that reducing the level of plasma in the fluid enhances the microorganism inactivation using endogenous or endogenously-based derivative photosensitizers, requiring a lower level of photosensitizer to achieve the same level of microorganism inactivation, reducing the time required for a desired level of inactivation, reducing the light dose required for a desired level of inactivation, and reducing the need for ultraviolet light to achieve a desired level of inactivation.

35 The adjusting step may be any method useful to adjust the amount of plasma present in a sample, or any method useful to reduce the amount of a particular component of plasma in a sample. One method suitable for the adjusting step is diluting the fluid with a diluting

5 solution. This will reduce the level of all plasma constituents. The diluting solution used to bring the level of plasma to a desired value may be one of many different solutions, including saline; a buffer, which may comprise a variety of different substances; a solution containing glucose, phosphate or both, which may or may not act as a buffer; a solution containing  
10 nutrients for a component of the sample; a cryopreservative; an anticoagulant; a cell storage solution known to the art or developed to provide cells with suitable additives to enable them to be stored or infused; or other suitable solution. The solution should not substantially interfere with the inactivation of microorganisms or substantially destroy the biological activity of the fluid. As long as any interference the solution has with the inactivation  
15 process is not so great as to prevent inactivation from occurring at a desired level, the solution does not “substantially interfere.” As long as the fluid is useful for its intended or natural purpose, the solution does not “substantially destroy” the biological activity. Selected proteins in plasma may be reduced selectively by proper selection of reagents and filtration. Such reagents and methods of filtering are known in the art. One such filter is a hollow fiber  
20 filter. The adjusting step may also be carried out using a mechanical means such as by centrifuging the fluid to separate the components, collecting the desired component or components and resuspending the desired component or components in a suitable solution. The process may be carried out more than once, to achieve the desired level of plasma adjustment. The process may also be carried out using gravity to separate the components.  
25 The adjusting step may also comprise washing the fluid one or more times, as known in the art. Washing is generally adding a solution to reduce the level of plasma in extracellular space between the cells. The fluid may be washed with a detergent solution or saline, for example.

30 In one embodiment of the invention, the amount of one component of plasma, for example, bilirubin or albumin, may be reduced selectively. The amount of bilirubin in a sample may be reduced by filtration through resin cartridges or washing or pre-irradiation with 447 nm light to break down the bilirubin, or any other method known to the art. Alternatively, the amount of the total plasma in the sample may be reduced. Both of these  
35 embodiments are intended to be encompassed by terms such as “reducing the percentage of plasma” and the like.

The mixing step may occur before, after or simultaneously with the adjusting step.

35 The photosensitizer may be a photo-activatable compound whose photolytic products (if any) are of low or no toxicity to humans or animals. The most preferred photosensitizer is 7,8-dimethyl-10-ribityl isoalloxazine.



5 The percentage of plasma in the fluid in the methods of the invention may be adjusted to any desired level that provides the effect of measurably improving the inactivation of microorganisms as compared to a fluid of the same composition if the percentage of plasma had not been reduced. Improving the inactivation of microorganisms means the light dose required for a desired level of inactivation is lower, the wavelength range of light required to inactivate a desired number of microorganism is narrower, the level of photosensitizer required is lower, the time required for a desired level of microorganism inactivation is shorter than required in a fluid of the same composition if the percentage of plasma had not been reduced, or a combination of these effects.

10 Photoradiation may comprise light in the visible spectrum, the ultraviolet spectrum, or light in both the visible and ultraviolet spectra. Any suitable wavelength or wavelengths of light may be used in any proportion and energy that produces the desired level of inactivation of microorganisms. For example, about half the light may be in the visible spectrum and about half the light may be in the ultraviolet spectrum. Alternatively, about one third of light may be in one spectral range and the other two thirds of light in the other spectral range. In one embodiment of the invention, two light sources (or two arrays of light sources) are used, to provide two wavelengths of light. As used herein, "wavelength" does not necessarily mean one discrete wavelength. Wavelength may comprise a range of about  $\pm 100$  nm centered around one wavelength. Preferably, if ultraviolet light is used, the amount of ultraviolet light is kept to a level that minimizes damage to desired fluid components. Generally, this is provided by using 50% or less ultraviolet light relative to the total light energy delivered.

25 The fluid containing the photosensitizer is exposed to photoradiation of the appropriate wavelength to activate the photosensitizer, using an amount of photoradiation sufficient to activate the photosensitizer as described herein, but less than that which would cause non-specific damage to the biological components or substantially interfere with biological activity of other proteins present in the fluid. The wavelength used will depend on the photosensitizer selected and composition of the fluid, as is known to the art or readily determinable without undue experimentation following the teachings disclosed herein. Non-specific damage is damage that damages all components.

35 The photoradiation in both the ultraviolet and visible spectra may be supplied concurrently or sequentially, with the visible portion preferably being supplied first. The photoradiation source may be a simple lamp or may consist of multiple lamps radiating at

differing wavelengths. The photoradiation source should be capable of delivering a sufficient amount of light to activate the photosensitizer, preferably from about 100 to at least about 200 J/cm<sup>2</sup>.

5 Also provided is an apparatus for inactivating microorganisms which may be present in a fluid with an endogenous or endogenously-based derivative photosensitizer, comprising:

- (a) a source of light that emits light of a suitable wavelength and intensity to activate the endogenous or endogenously-based derivative photosensitizer;
- (b) means for maintaining the fluid and an effective amount of an endogenous or

10 endogenously-based derivative photosensitizer in the light path for a sufficient time to achieve the desired level of inactivation.

The means for maintaining the fluid and an effective amount of an endogenous or endogenously-based derivative photosensitizer in the light path may comprise a support

15 surface substantially parallel to said source of light; a cuvette and flow-through system; or other means known in the art.

Also provided is a system for treating a fluid to inactivate microorganisms which may be present therein with an endogenous or endogenously based derivative photosensitizer

20 comprising:

- (a) a container comprising said fluid having a desired level of plasma, at least an effective amount of an endogenous photosensitizer or endogenously-based derivative photosensitizer, and optionally one or more additives, said container having a photopermeable surface sufficient to allow exposure of the fluid
- 25 therein to an amount of photoradiation sufficient to activate the photosensitizer;
- (b) at least one photoradiation source in light communication with said container, said source capable of generating a suitable wavelength and intensity to activate the endogenous photosensitizer or endogenously-based derivative
- 30 photosensitizer whereby microorganisms present are inactivated.

Also provided is a system for inactivation of microorganisms in a fluid containing such microorganisms comprising:

- (a) means for adjusting the plasma content of said fluid;
  - (b) means for mixing an effective amount of an endogenous photosensitizer or
- 35 endogenously-based derivative photosensitizer with said fluid;

- 5
- (c) a photopermeable container for said fluid in fluid communication with said means for adding photosensitizer and said means for adjusting the plasma content having a depth and length selected to allow exposure of the fluid of step (b) therein to an amount of photoradiation sufficient to activate the photosensitizer at a selected flow rate;
  - (d) means for producing said selected flow rate of said fluid through said container; and
  - (e) at least one photoradiation source for providing sufficient photoradiation to the fluid in said container of a type and amount selected to activate the photosensitizer.
- 10

Also provided is a system for treating a fluid to inactivate microorganisms which may be present therein comprising:

- 15
- (a) means for adjusting the percentage of plasma in said fluid;
  - (b) a photosensitizer in powdered form;
  - (c) a photopermeable container for containing said fluid and photosensitizer;
  - (d) means for agitating said container;
  - (e) at least one photoradiation source in light communication with said container, said source capable of providing sufficient photoradiation to the fluid in said container of a type and amount selected to activate the photosensitizer whereby microorganisms are inactivated.
- 20

The photopermeable container may be a transparent plastic bag, a transparent plastic container with rigid walls, or other containers as known to the art. The agitation may be provided by a shaker table, or other means for agitating known to the art.

25

Also provided is a method for collecting a fluid with reduced levels of microorganisms that may be present therein, said fluid containing one or more members of the group consisting of: blood and blood components, comprising:

- 30
- (a) placing said fluid in a photopermeable container;
  - (b) adding an endogenous or endogenously-based derivative photoactive material;
  - (c) adjusting the level of plasma in the blood or blood component to a desired level;
  - (d) exposing said fluid to radiation of a sufficient wavelength and intensity to inactivate microorganisms which may be present in said blood or blood component.
- 35

Also provided is an apparatus for collecting a fluid with reduced levels of microorganisms that may be present therein, said fluid containing one or more members of the group consisting of: blood and blood components, comprising:

- (a) a photopermeable container containing an endogenous or endogenously-based derivative photoactive material and a suitable volume of a solution for adjusting the level of plasma in the blood or blood component to a desired level;
- (b) a light source that emits light of a suitable wavelength and intensity to inactivate microorganisms which may be present in said fluid.

As used herein, the term "inactivation of a microorganism" means totally or partially preventing the microorganism from replicating, either by killing the microorganism or otherwise interfering with its ability to reproduce.

Microorganisms include viruses (both extracellular and intracellular), bacteria, bacteriophages, fungi, blood-transmitted parasites, and protozoa. Exemplary viruses include acquired immunodeficiency (HIV) virus, hepatitis A, B and C viruses, sinbis virus, cytomegalovirus, vesicular stomatitis virus, herpes simplex viruses, e.g. types I and II, human T-lymphotropic retroviruses, HTLV-III, lymphadenopathy virus LAV/IDAV, parvovirus, transfusion-transmitted (TT) virus, Epstein-Barr virus, and others known to the art. Bacteriophages include  $\Phi$ X174,  $\Phi$ 6,  $\lambda$ , R17, T<sub>4</sub>, and T<sub>2</sub>. Exemplary bacteria include *P. aeruginosa*, *S. aureus*, *S. epidermis*, *L. monocytogenes*, *E. coli*, *K. pneumonia* and *S. marcescens*.

Inactivation of white blood cells may be desirable when suppression of immune or autoimmune response is desired, e.g., in processes involving transfusion of red cells, platelets or plasma when donor white blood cells may be present. The process disclosed may be used to inactivate white blood cells.

Materials which may be treated by the methods of this invention include any materials which are adequately permeable to photoradiation to provide sufficient light to achieve microorganism inactivation, or which can be suspended or dissolved in fluids which have such permeability to photoradiation. Examples of such materials are whole blood and aqueous compositions containing biologically active proteins derived from blood or blood constituents. Packed red cells, platelets and plasma (fresh or fresh frozen plasma) are exemplary of such blood constituents. In addition, therapeutic protein compositions containing proteins derived from blood, such as fluids containing biologically active protein

useful in the treatment of medical disorders, e.g. factor VIII, Von Willebrand factor, factor IX, factor X, factor XI, Hageman factor, prothrombin, anti-thrombin III, fibronectin, plasminogen, plasma protein fraction, immune serum globulin, modified immune globulin, albumin, plasma growth hormone, somatomedin, plasminogen streptokinase complex, ceruloplasmin, transferrin, haptoglobin, antitrypsin and prekallikrein may be treated by the decontamination methods of this invention. The activity of a biologically-active protein in said fluid is at a biologically-active level after said exposing step. A therapeutic protein present in said fluid remains able to perform a therapeutic function after the exposing step. Other fluids which could benefit from the treatment of this invention are peritoneal solutions used for peritoneal dialysis which are sometimes contaminated during connection, leading to peritoneal infections.

The term "biologically active" means capable of effecting a change in a living organism or component thereof. "Biologically active" with respect to "biologically active protein" as referred to herein does not refer to proteins which are part of the microorganisms being inactivated. Similarly, "non-toxic" with respect to the photosensitizers means low or no toxicity to humans and other mammals, and does not mean non-toxic to the microorganisms being inactivated. "Substantial destruction" of biological activity means at least as much destruction as is caused by porphyrin and porphyrin derivatives, metabolites and precursors which are known to have a damaging effect on biologically active proteins and cells of humans and mammals. Similarly, "substantially non-toxic" means less toxic than porphyrin, porphyrin derivatives, metabolites and precursors that are known for blood sterilization.

The term "blood product" as used herein includes blood constituents and therapeutic protein compositions containing proteins derived from blood as defined above. Fluids containing biologically active proteins other than those derived from blood may also be treated by the methods of this invention.

Decontamination methods of this invention using endogenous photosensitizers and endogenously-based photosensitizer derivatives do not substantially destroy the biological activity of fluid components other than microorganisms. As much biological activity of these components as possible is retained, although in certain instances, when the methods are optimized, some loss of biological activity, e.g., denaturation of protein components, must be balanced against effective decontamination of the fluid. So long as fluid components retain sufficient biological activity to be useful for their intended or natural purposes, their biological activities are not considered to be "substantially destroyed."

Photosensitizers are known to be useful for inactivating microorganisms. A “photosensitizer” is defined as any compound which absorbs radiation of one or more defined wavelengths and subsequently utilizes the absorbed energy to carry out a chemical process. Examples of such photosensitizers include porphyrins, psoralens, dyes such as neutral red, methylene blue, acridine, toluidines, flavine (acriflavine hydrochloride) and phenothiazine derivatives, coumarins, quinolones, quinones, and anthroquinones. Photosensitizers of this invention may include compounds which preferentially adsorb to nucleic acids, thus focusing their photodynamic effect upon microorganisms and viruses with little or no effect upon accompanying cells or proteins. Other photosensitizers are also useful in this invention, such as those using singlet oxygen-dependent mechanisms. Most preferred are endogenous photosensitizers. The term “endogenous” means naturally found in a human or mammalian body, either as a result of synthesis by the body or because of ingestion as an essential foodstuff (e.g. vitamins) or formation of metabolites and/or byproducts *in vivo*. Examples of such endogenous photosensitizers are alloxazines such as 7,8-dimethyl-10-ribityl isoalloxazine (riboflavin), 7,8,10-trimethylisoalloxazine (lumiflavin), 7,8-dimethylalloxazine (lumichrome), isoalloxazine-adenine dinucleotide (flavine adenine dinucleotide [FAD]), alloxazine mononucleotide (also known as flavine mononucleotide [FMN] and riboflavine-5-phosphate), vitamin Ks, vitamin L, their metabolites and precursors, and naphthoquinones, naphthalenes, naphthols and their derivatives having planar molecular conformations. The term “alloxazine” includes isoalloxazines. Endogenously-based derivative photosensitizers include synthetically derived analogs and homologs of endogenous photosensitizers which may have or lack lower (1-5) alkyl or halogen substituents of the photosensitizers from which they are derived, and which preserve the function and substantial non-toxicity thereof. When endogenous photosensitizers are used, particularly when such photosensitizers are not inherently toxic or do not yield toxic photoproducts after photoradiation, no removal or purification step is required after decontamination, and treated product can be directly returned to a patient's body or administered to a patient in need of its therapeutic effect.

Non-endogenous photosensitizers based on endogenous structures, such as those described in U.S. Patent Application 09/420,652 are also included. These non-endogenous photosensitizers and endogenously-based derivative photosensitizers are referred to herein as endogenously-based derivative photosensitizers.

As used herein, “powder” means dried medium, including powder or pill. When a dried medium of a substance is described herein, it is also intended that a solution or suspension of the powder in a suitable solvent may be used, and vice versa.

The method of this invention requires mixing the photosensitizer with the material to be decontaminated. "Adding" is intended to include mixing the fluid with the photosensitizer. Mixing may be done by simply adding the photosensitizer or a solution containing the photosensitizer to a fluid to be decontaminated. In one embodiment, the material to be decontaminated to which photosensitizer has been added is flowed past a photoradiation source, and the flow of the material generally provides sufficient turbulence to distribute the photosensitizer throughout the fluid to be decontaminated. In another embodiment, the fluid and photosensitizer are placed in a photopermeable container and irradiated in batch mode, preferably while agitating the container to fully distribute the photosensitizer and expose all the fluid to the radiation.

The amount of photosensitizer to be mixed with the fluid will be an amount sufficient to adequately inactivate microorganisms therein, but less than a toxic (to humans or other mammals) or insoluble amount. Excess photosensitizer may be used as long as the concentration is not so high that the photosensitizer prevents light from passing to the desired depth at a useful intensity. As taught herein, optimal concentrations for desired photosensitizers may be readily determined by those skilled in the art without undue experimentation. Preferably the photosensitizer is used in a concentration of at least about 1 micromolar. The optimum concentration of photosensitizer will vary depending on the blood component being treated and the level to which plasma is removed. If red blood cells are being treated, a higher concentration of photosensitizer is desired than if plasma or platelets are being treated. If red blood cells are being treated with riboflavin, a useful concentration of riboflavin is about 1-200 micromolar, and a preferred concentration of riboflavin is about 50 to 150 micromolar when the plasma content is about 0 to 5% of the total volume of the solution. If plasma or platelets are being treated, a useful concentration of riboflavin is about 1-100 micromolar, and a preferred concentration of riboflavin is about 10 to 30 micromolar when the plasma content is about 10 - 90% of the total volume of the solution.

The activated photosensitizer is capable of inactivating the microorganisms present, such as by interfering to prevent their replication. Specificity of action of the photosensitizer is conferred by the close proximity of the photosensitizer to the nucleic acid of the microorganism and this may result from binding of the photosensitizer to the nucleic acid. "Nucleic acid" includes ribonucleic acid (RNA) and deoxyribonucleic acid (DNA). Other photosensitizers may act by binding to cell membranes or by other mechanisms. The photosensitizer may also be targeted to the microorganism to be inactivated by covalently coupling to an antibody, preferably a specific monoclonal antibody to the microorganism.

5 The fluid containing the photosensitizer may be flowed into a photopermeable container for irradiation. The term "container" refers to a closed or open space, which may be made of rigid or flexible material, e.g., may be a bag or box or trough. It may be closed or open at the top and may have openings at both ends, e.g., may be a tube or tubing, to allow for flow-through of fluid therein. A cuvette has been used to exemplify one embodiment of the invention involving a flow-through system. Collection bags, such as those used with the Trima™ Spectra™ and apheresis systems of GAMBRO, Inc., have been used to exemplify another embodiment involving batch-wise treatment of the fluid.

10 The term "photopermeable" means the material of the container is adequately transparent to photoradiation of the proper wavelength for activating the photosensitizer. In the flow-through system, the container has a depth (dimension measured in the direction of the radiation from the photoradiation source) sufficient to allow photoradiation to adequately penetrate the container to contact photosensitizer molecules at all distances from the light source and ensure inactivation of microorganisms in the fluid to be decontaminated, and a length (dimension in the direction of fluid flow) sufficient to ensure a sufficient exposure time of the fluid to the photoradiation. The materials for making such containers, depths and lengths of containers may be easily determined by those skilled in the art without undue experimentation following the teachings herein, and together with the flow rate of fluid through the container, the intensity of the photoradiation and the absorptivities of the fluid components, e.g., plasma, platelets, red blood cells, will determine the amount of time the fluid needs to be exposed to photoradiation.

25 In another embodiment involving batch-wise treatment, the fluid to be treated is placed in a photopermeable container which is agitated and exposed to photoradiation for a time sufficient to substantially inactivate the microorganisms. The photopermeable container is preferably a blood bag made of transparent or semitransparent plastic, and the agitating means is preferably a shaker table. The photopermeable container may be any other container, such as a rigid plastic container. The photosensitizer may be added to the container in powdered or liquid form and the container agitated to mix the photosensitizer with the fluid and to adequately expose all the fluid to the photoradiation to ensure inactivation of microorganisms.

35 Photosensitizer may be added to or flowed into the photopermeable container separately from the fluid being treated or may be added to the fluid prior to placing the fluid



in the container. In one embodiment, photosensitizer is added to anticoagulant and the mixture of photosensitizer and anticoagulant are added to the fluid.

5 After treatment, the blood or blood product may be delivered to a patient, concentrated, or infused directly.

Enhancers may also be added to the fluid to make the process more efficient and selective. Such enhancers include antioxidants or other agents to prevent damage to desired fluid components or to improve the rate of inactivation of microorganisms and are  
10 exemplified by adenine, histidine, cysteine, tyrosine, tryptophan, ascorbate, N-acetyl-L-cysteine, propyl gallate, glutathione, mercaptopropionylglycine, dithiothreitol, nicotinamide, BHT, BHA, lysine, serine, methionine, glucose, mannitol, trolox, glycerol, and mixtures thereof. These enhancers may be added in dried medium, including powder or pill form or in the form of liquids.

15 This invention also comprises fluids comprising biologically active protein, blood or blood constituents and also containing endogenous photosensitizer, endogenously-based derivative photosensitizer, or photoproduct thereof made by the inactivation methods described herein. The fluid may also contain inactivated microorganisms.

20 In addition to decontamination of whole blood, fluids containing blood products and biologically active proteins, this method is useful for treating other fluids including fluids which are meant for nourishment of humans or animals such as water, fruit, juices, milk, broths, soups and the like. The method is also useful for treating peritoneal or parenteral  
25 solutions.

In decontamination systems of this invention, the photoradiation source may be connected to the photopermeable container for the fluid by means of a light guide such as a light channel or fiber optic tube which prevents scattering of the light between the source and  
30 the container for the fluid, and more importantly, prevents substantial heating of the fluid within the container. Direct exposure to the light source may raise temperatures as much as 10 to 15 °C, especially when the amount of fluid exposed to the light is small, which can cause denaturization of blood components. Use of the light guide keeps any heating to less than about 2 °C. The method may also include the use of temperature sensors and cooling  
35 mechanisms where necessary to keep the temperature below temperatures at which desired proteins in the fluid are damaged. Cooling mechanisms include flow of air or fluid, as well as other mechanisms known to the art. Preferably, the temperature is kept between about 0°C

and about 45°C, more preferably between about 22°C and about 45°C, and preferably about 40°C, depending on the composition of the fluid.

5 Any means for adding the photosensitizer to the fluid to be decontaminated and for placing the fluid in the photopermeable container known to the art may be used, such means typically including flow conduits, ports, reservoirs, sterile docking, valves, and the like. The system may include means such as pumps or adjustable valves for controlling the flow of the photosensitizer into the fluid to be decontaminated so that its concentration may be controlled at effective levels as described herein. In one embodiment, photosensitizer is mixed with the  
10 anticoagulant feed to a blood apheresis system. For endogenous photosensitizers and derivatives having sugar moieties, the pH of the solution is preferably kept low enough, as is known to the art, to prevent detachment of the sugar moiety. Preferably the photosensitizer is added to the fluid to be decontaminated in a pre-mixed aqueous solution, e.g., in water or storage buffer solution.

15 The photosensitizer and any optional desired additives may be placed in a container as dried medium, including powder or pill form, or as a solution. Desired additives include nutrients or other materials such as acetate, glucose, dextrose, citrate, pyruvate, which allow the components to retain biological activity or improve the storage lifetime. It may be desirable for platelets to be provided nutrients when the plasma concentration is less than  
20 about 20% of the total volume of the sample in order for the platelets to remain active. Desired additives and the photosensitizer may be sterilized as powders. In one embodiment, the powders desired are placed in the container prior to introduction of the fluid.

25 If the photosensitizer and any desired additives are placed in the container as one or more solutions, the volume and composition of the solution(s) may produce the desired percentage of plasma in the sample, without further additions of solution, or the percentage of plasma may be adjusted before, during or after placing said fluid in said container. Adjustment of the percentage of plasma after placing the fluid in the container may occur by  
30 the introduction of a suitable solution after the fluid is in the container. Adjustment of the percentage of plasma may occur during introduction of the fluid in a container by the introduction of a suitable solution as the fluid is being placed in the container.

35 The photopermeable container for the flow-through system may be a transparent cuvette made of polycarbonate, glass, quartz, polystyrene, polyvinyl chloride, polyolefin, or other transparent material. The cuvette may be enclosed in a radiation chamber having mirrored walls. A photoradiation enhancer such as a second photoradiation source or

reflective surface may be placed adjacent to the cuvette to increase the amount of photoradiation contacting the fluid within the cuvette. The system preferably includes a pump for adjusting the flow rate of the fluid to desired levels to ensure substantial decontamination as described above. The cuvette has a length, coordinated with the flow rate therethrough, sufficient to expose fluid therein to sufficient photoradiation to effect substantial decontamination thereof.

Also preferably the cuvette is spaced apart from the light source a sufficient distance that heating of the fluid in the cuvette does not occur, and light is transmitted from the light source to the cuvette by means of a light guide.

In another embodiment the fluid is placed in a photopermeable container such as a blood bag, e.g. used with the apheresis system described in U.S. Patent No. 5,653,887, and agitated while exposing to photoradiation. Suitable bags include collection bags as described herein. Collection bags used in the Spectra™ system or Trima™ apheresis system of GAMBRO Inc. are especially suitable. Shaker tables are known to the art, e.g. as described in U.S. Patent 4,880,788. The bag is equipped with at least one port or opening for adding fluid thereto. In one embodiment the photosensitizer, preferably 7,8-dimethyl-10-ribityl-isoalloxazine, is added to the fluid-filled bag as dried medium, including powder or pill form. The bag is then placed on a shaker table and agitated under photoradiation until substantially all the fluid has been exposed to the photoradiation. Alternatively, the bag may be prepackaged with the powdered photosensitizer contained therein. The fluid to be decontaminated may then be added through the appropriate port.

Decontamination systems as described above may be designed as stand-alone units or may be easily incorporated into existing apparatuses known to the art for separating or treating blood being withdrawn from or administered to a patient. For example, such blood-handling apparatuses include the GAMBRO Spectra™ or TRIMA® apheresis systems, available from GAMBRO Inc., Lakewood, CO, or the apparatuses described in U.S. Patent 5,653,887 and U.S. Serial No. 08/924,519 filed September 5, 1997 (PCT Publication No. WO 99/11305) of GAMBRO, Inc. as well as the apheresis systems of other manufacturers. The decontamination system may be inserted just downstream of the point where blood is withdrawn from a patient or donor, just prior to insertion of blood product into a patient, or at any point before or after separation of blood constituents. The plasma may be adjusted at any point before fluid is exposed to irradiation. The photosensitizer is added to blood components along with anticoagulant in a preferred embodiment, and separate irradiation sources and cuvettes are placed downstream from collection points for platelets, for plasma

and for red blood cells. The use of three separate blood decontamination systems is preferred to placement of a single blood decontamination system upstream of the blood separation vessel of an apheresis system because the lower flow rates in the separate component lines allows greater ease of irradiation. In other embodiments, decontamination systems of this invention may be used to process previously collected and stored blood products.

When red blood cells are present in the fluid being treated, as will be appreciated by those skilled in the art, to compensate for absorption of light by the cells, the fluid may be thinned, exposed to higher energies of radiation for longer periods, agitated for longer periods or presented to photoradiation in shallower containers or conduits than necessary for use with other blood components.

The endogenous photosensitizers and endogenously-based derivative photosensitizers disclosed herein can be used in pre-existing blood component decontamination systems as well as in the decontamination system disclosed herein. For example, the endogenous photosensitizers and endogenously-based derivative photosensitizers of this invention can be used in the decontamination systems described in U.S. Patent Nos. 5,290,221, 5,536,238, 5,290,221 and 5,536,238.

Platelet additive solutions comprising endogenous photosensitizers and endogenously-based derivative photosensitizers as described above are also provided herein. Platelet additive solutions known to the art may be used for this purpose and include those disclosed in U.S. Patent Nos. 5,908,742; 5,482,828; 5,569,579; 5,236,716; 5,089,146; and 5,459,030. Such platelet additive solutions may contain physiological saline solution, buffer, preferably sodium phosphate, and other components including magnesium chloride and sodium gluconate. The pH of such solutions is preferably between about 7.0 and 7.4. These solutions are useful as carriers for platelet concentrates to allow maintenance of cell quality and metabolism during storage, reduce plasma content and extend storage life. The photosensitizer may be present in such solutions at any desired concentration from about 1  $\mu\text{M}$  to the solubility of the photosensitizer in the solution, and preferably between about 10  $\mu\text{M}$  and about 100  $\mu\text{M}$ , more preferably about 10  $\mu\text{M}$ . In a preferred embodiment, the platelet additive solution also comprises enhancers as described above. A preferred platelet additive solution comprises sodium acetate, sodium chloride, sodium gluconate, 1.5 micromolar magnesium chloride, 1 micromolar sodium phosphate 14  $\mu\text{M}$  7,8-dimethyl-10-ribityl-isoalloxazine and preferably also 6 micromolar ascorbate. These platelet additive solutions may be added in a desired volume to a fluid so that the level of plasma is at a

desired level before irradiation, or platelet additive solutions may be used to resuspend a pellet. Other uses for platelet additive solutions are known to the art.

5 A photoradiation enhancer, such as a reflective surface may also be provided in any method or apparatus of the invention. The light may be guided to impinge on the fluid in any desired manner, including positioning the fluid in the light path of the light source, using a light guide, or other methods. The apparatuses of the invention may also comprise components such as a temperature monitor, temperature controller, means for flowing said fluid into and out of said container, means for agitating said fluid in said container, and other  
10 desired components to control various aspects of the system. The temperature controller may be a fan directed toward the light source, directed on the fluid, or both. One or more temperature controllers may be used to cool different components to different levels.

#### BRIEF DESCRIPTION OF THE FIGURES

15 Figure 1 depicts the riboflavin absorbance spectrum.

Figure 2 depicts a correlation of light absorbance and hematocrit observed and predicted for red blood cells, and predicted for platelets.

20 Figure 3 depicts photodecomposition over time of riboflavin in anticoagulant Acid Citrate Dextrose (ACD) solution. The solid line with circles indicates percent of initial riboflavin remaining at 373 nm. The dotted line with squares indicates percent of initial riboflavin remaining at 447 nm.

25 Figure 4 depicts the transmission profile of various plastic cuvettes as a function of wavelength. The solid line represent a 3.2 mm acrylic cuvette. The dotted line (----) represents a 3.2 mm UV acrylic cuvette. The dashed line (---) represents a 3.2 mm polystyrene (PS) cuvette, and the crossed line indicates a 3.2 mm polycarbonate (PC) cuvette.

30 Figure 5 depicts the light flux required in mW per  $\text{cm}^2$  as a function of flow rate, i.e. the flux required to deliver one joule/ $\text{cm}^2$  to a sample in the cuvette.

35 Figure 6 depicts a blood separation apparatus incorporating the photoradiation device of this invention.

Figure 7 depicts the decontamination assembly of this invention.

Figure 8 depicts inactivation of bacteria in platelet preparations using vitamin K5 as the photosensitizer as a function of energy of irradiation.

5 Figure 9 depicts inactivation of bacteria as a function of platelet preparation and energy of irradiation, using 90% platelets and 10% platelet additive solution (90:10) and 30% platelets with 70% additive solution (30:70).

10 Figure 10 shows the effect on inactivation of virus, bacteriophage and bacteria of adding antioxidants to platelet concentrate.

15 Figure 11 shows the inactivation curve for Herpes Simplex type II virus as a function of concentration of photosensitizer at an energy of irradiation of 20J/cm<sup>2</sup> using half ultraviolet and half visible light.

Figure 12 shows inactivation of *S. epidermidis* at varying concentrations of photosensitizer and energies of irradiation.

20 Figure 13 shows inactivation of  $\Phi$ X174 at varying concentrations of photosensitizer and energies of irradiation.

Figure 14 shows inactivation of *S. aureus* and  $\Phi$ X174 at varying energies of irradiation using a 50:50 mixture of ultraviolet and visible light.

25 Figure 15 shows inactivation of *S. epidermidis* and HSV-II at varying energies of irradiation using a 50:50 mixture of ultraviolet and visible light.

30 Figure 16 shows inactivation of HSV2 virus in blood bags agitated and irradiated at varying energy levels.

Figure 17 compares inactivation results for vaccinia virus in various fluids using ultraviolet light alone or 50:50 visible and ultraviolet light.

35 Figure 18 compares inactivation results with and without sensitizer of vaccinia virus at varying irradiation times.

Figure 19 compares inactivation of extracellular HIV-1 at 5 and 50  $\mu\text{M}$  of photosensitizer and varying irradiation energies.

5 Figure 20 compares inactivation of intracellular HIV-1 at 5 and 50  $\mu\text{M}$  of photosensitizer and varying irradiation energies.

Figure 21 compares inactivation of intracellular HIV-1 at 5 and 50  $\mu\text{M}$  of photosensitizer and varying irradiation energies, using p24 antigen levels.

10 Figure 22 shows inactivation of HSV-II at varying irradiation levels using platelet concentrate and platelet concentrate in media containing platelet additive solution with ascorbate.

15 Figure 23 shows an embodiment of this invention using a blood bag to contain the fluid being treated and photosensitizer and a shaker table to agitate the fluid while exposing to photoradiation from a light source.

20 Figure 24 shows inactivation of Phi-6 (pfu/mL) as a function of hematocrit percent using 447 nm light and 102  $\text{J}/\text{cm}^2$ .

Figure 25 shows inactivation of Phi-6 as a function of plasma content for red blood cells diluted in AS-3 with a final concentration of 100 micromolar riboflavin with 102  $\text{J}/\text{cm}^2$  447 nm light.

25 Figure 26 shows inactivation of Phi-X174 as a function of plasma content for red blood cells diluted in AS-3 with a final concentration of 50 micromolar riboflavin with 102  $\text{J}/\text{cm}^2$  447 nm light.

30 Figure 27 shows inactivation of Phi-6 as a function of energy of light applied for full red cell units with a hematocrit of 35-40% diluted with AS-3 in a 2L bag with a final concentration of 100 micromolar riboflavin using 447 or 470 nm light.

35 Figure 28 shows inactivation of Phi-6 using 447 nm lights at hematocrits of 10%, 40% and 60% with increasing energy applied using 50 micromolar riboflavin.

Figure 29 shows inactivation of Phi-6 in red blood cells with 35 % hematocrit diluted in AS-3 and % hemolysis as a function of time of exposure to 470 nm light and 100 micromolar riboflavin.

5 Figure 30 shows inactivation of Phi-6 in red blood cells with 37 % hematocrit diluted in AS-3 and % hemolysis as a function of time of exposure to 447 nm light and 100 micromolar riboflavin.

10 Figure 31 shows inactivation of BVDV in red blood cells with 35-40% hematocrit with 447 nm light at varying energies.

Figure 32 shows protein factor activity levels as a function of energy levels using a stericon bag, no air, with 10 micromolar riboflavin.

15 Figure 33 shows protein factor activity levels as a function of energy levels using a stericon bag with air and 10 micromolar riboflavin.

Figure 34 shows protein factor activity levels as a function of energy levels using a stericon bag with air, 10 micromolar ascorbate and 10 micromolar riboflavin.

20

Figure 35 shows the spectral output for the "470nm" light used in the experiments.

Figure 36 shows the spectral output for the "420nm" light used in the experiments.

25

#### DETAILED DESCRIPTION OF THE INVENTION

The decontamination method of this invention using endogenous photosensitizers and endogenously-based derivative photosensitizers is exemplified herein using 7,8-dimethyl-10-ribityl isoalloxazine as the photosensitizer, however, any photosensitizer may be used which is capable of being activated by photoradiation to cause inactivation of microorganisms. The photosensitizer must be one which does not substantially destroy desired components of the fluid being decontaminated, and also preferably which does not break down as a result of the photoradiation into products which significantly destroy desired components or have significant toxicity. The wavelength at which the photosensitizer is activated is determined as described herein, using literature sources or direct measurement. Its solubility in the fluid to be decontaminated or in a combination of carrier fluid and fluid to be contaminated is also so determined. The ability of photoradiation at the activating wavelength to penetrate the fluid to be decontaminated must also be determined as taught herein. The desired level of

30  
35



plasma in the fluid is also determined as described herein. Appropriate temperatures for the reaction of the photosensitizer with its substrate are determined, as well as the ranges of temperature, photoradiation intensity and duration and photosensitizer concentration which will optimize microbial inactivation and minimize damage to desired proteins and/or cellular components in the fluid.

Once such system requirements have been determined for flow-through systems, apparatuses may be designed which provide the correct flow rates, photopermeabilities, plasma contents, light wavelengths and light intensities to cause inactivation of microorganisms present in the fluid, as is taught herein. In one embodiment, the plasma content of a fluid to be decontaminated is adjusted, the fluid is mixed with photosensitizer and then irradiated with a sufficient amount of photoradiation to activate the photosensitizer to react with microorganisms in the fluid such that microorganisms in the fluid are inactivated. The amount of photoradiation reaching microorganisms in the fluid is controlled by selecting an appropriate photoradiation source, an appropriate distance of the photoradiation source from the fluid to be decontaminated, which may be increased through the use of light guides to carry the photoradiation directly to the container for the fluid, an appropriate photopermeable material for the container for the fluid, an appropriate depth to allow full penetration of the photoradiation into the container, photoradiation enhancers such as one or more additional photoradiation sources, preferably on the opposite side of the container from the first, or reflectors to reflect light from the radiation source back into the container, appropriate flow rates for the fluid in the container and an appropriate container length to allow sufficient time for inactivation of microorganisms present. Temperature monitors and controllers may also be required to keep the fluid at optimal temperature. Figure 6 depicts a decontamination system of this invention as part of an apparatus for separating blood components, and Figure 7 provides details of a preferred decontamination system.

For batch systems, it is preferred to place the fluid to be decontaminated along with photosensitizer in bags which are photopermeable or at least sufficiently photopermeable to allow sufficient radiation to reach their contents to activate the photosensitizer. Sufficient photosensitizer is added to each bag to provide inactivation, and the bag is preferably agitated while irradiating, for a period of time to ensure exposure of substantially all the fluid to radiation. The photosensitizer may be added in powdered form.

The method preferably uses endogenous photosensitizers, including endogenous photosensitizers which function by interfering with nucleic acid replication. 7,8-dimethyl-10-

ribityl isoalloxazine is the preferred photosensitizer for use in this invention. The chemistry believed to occur between 7,8-dimethyl-10-ribityl isoalloxazine and nucleic acids does not proceed via singlet oxygen-dependent processes (i.e. Type II mechanism), but rather by direct sensitizer-substrate interactions (Type I mechanisms). Cadet et al. (1983) J. Chem., 23:420-429, clearly demonstrate the effects of 7,8-dimethyl-10-ribityl isoalloxazine are due to non-singlet oxygen oxidation of guanosine residues. In addition, adenosine bases appear to be sensitive to the effects of 7,8-dimethyl-10-ribityl isoalloxazine plus UV light. This is important since adenosine residues are relatively insensitive to singlet oxygen-dependent processes. 7,8-dimethyl-10-ribityl isoalloxazine appears not to produce large quantities of singlet oxygen upon exposure to UV light, but rather exerts its effects through direct interactions with substrate (e.g., nucleic acids) through electron transfer reactions with excited state sensitizer species. Since indiscriminate damage to cells and proteins arises primarily from singlet oxygen sources, this mechanistic pathway for the action of 7,8-dimethyl-10-ribityl isoalloxazine allows greater selectivity in its action than is the case with compounds such as psoralens which possess significant Type II chemistry.

7,8-dimethyl-10-ribityl isoalloxazine (Riboflavine or vitamin B2) absorbs light from about 200 to 500 nm. The ring system core of 7,8-dimethyl-10-ribityl isoalloxazine is resistant to photodegradation but the ribityl side chain of riboflavin undergoes photodegradation. Photolysis of 7,8-dimethyl-10-ribityl isoalloxazine may form lumichrome (7,8-dimethylalloxazine) depending on conditions. 7,8-dimethylalloxazine strongly absorbs ultraviolet (UV) light and only weakly absorbs visible light.

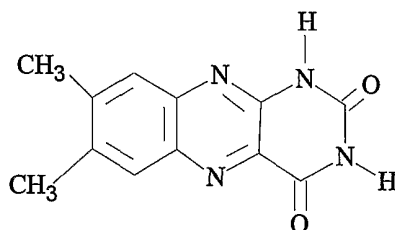

7,8-dimethylalloxazine

As a result of the degradation of 7,8-dimethyl-10-ribityl isoalloxazine upon exposure to light, a combination of visible and ultraviolet light is preferred in decontamination procedures using 7,8-dimethyl-10-ribityl isoalloxazine. Since UV light has a higher energy per photon than visible light, and because UV light is absorbed more strongly than visible light by useful compounds in the biological fluid, more damage to the useful components in

the biological fluid containing the contaminants will occur when ultraviolet light is used in combination with visible light than when visible light can be used alone.

5 Figure 6 shows a blood apparatus device and apheresis system incorporating the photoradiation devices of this invention. Whole blood is withdrawn from a donor/patient 4 and is provided to an apheresis system or blood component separation device 8 where the blood is separated into the various component types and at least one of these blood component types is removed from the device 8. These blood components may then be provided for subsequent use by another or may undergo a therapeutic treatment and be  
10 returned to the donor/patient 4.

In the blood component separation device 8, blood is withdrawn from the donor/patient 4 and directed through an extracorporeal tubing circuit 10 and a blood-processing vessel 12, defining a completely closed and sterile system. The blood component  
15 separation device 8 is connected to a pump (not shown). Blood flows from the donor/patient 4 through the extracorporeal tubing circuit 10 and into rotating blood processing vessel 12. The blood within the blood processing vessel 12 is separated into various blood component types, and these component types (platelets, plasma, red blood cells) are continually removed from the blood processing vessel 12. Blood components which are not being retained for  
20 collection or for therapeutic treatment (e.g., red blood cells, white blood cells, plasma) are also removed from the blood processing vessel 12 and returned to the donor/patient 4 via the extracorporeal tubing circuit 10.

Operation of the blood component separation device is preferably controlled by one or  
25 more computer processors included therein.

Extracorporeal tubing circuit 10 comprises a cassette assembly 14 and a number of tubing assemblies 20, 50, 60, 80, 90, 100 interconnected therewith. Blood removal/return tubing assembly 20 provides a single needle interface between a donor/patient 4 and cassette  
30 assembly 14, and blood inlet/blood component tubing subassembly 60 provides the interface between cassette assembly 14 and blood processing vessel 12. An anticoagulant tubing assembly 50, platelet collection tubing assembly 80, plasma collection tubing assembly 90, red blood cell collection tubing assembly 70 and vent bag tubing subassembly 100 are also interconnected with cassette assembly 14.  
35

The blood removal/return tubing assembly **20** includes a needle subassembly **30** interconnected therewith and anticoagulant tubing **26** connecting to anticoagulant tubing assembly **50** through cassette assembly **14**.

5           Cassette assembly **14** includes front and back molded plastic plates that are hot-welded together to define a rectangular cassette member having integral fluid passageways. The cassette assembly **14** further includes a number of outwardly extending tubing loops interconnecting various integral passageways. The integral passageways are also interconnected to the various tubing assemblies.

10           Specifically, cassette assembly **14** interconnects with anticoagulant tubing **26** of the blood removal/return tubing assembly **20** and with anticoagulant tubing assembly **50**. The anticoagulant tubing assembly **50** includes a spike drip chamber **52** connectable to anticoagulant and photosensitizer source **53** and a sterilizing filter **56**. During use, the  
15           anticoagulant tubing assembly **50** supplies anticoagulant mixed with photosensitizer to the blood removed from donor/patient **4** to reduce or prevent any clotting in the extracorporeal tubing circuit **10**. Many anticoagulants are known to the art, e.g. as disclosed in Chapter 3 of the AABB Technical Manual, 11th edition, 1993, including ACD-A, CPD, CP2D, CPDA-1 and heparin. These as well as cell storage solutions, AS-1, AS-3 and AS-5, are all  
20           compatible with the endogenous photosensitizers and endogenously-based derivative photosensitizers described herein.

          Cassette assembly **14** also includes an interconnection with blood removal tubing of the blood removal/return tubing assembly **20**. Blood passes through pressure sensors, and an  
25           inlet filter in cassette assembly **14** and thence to blood inlet tubing **62**. Blood inlet tubing **62** is also interconnected with blood processing vessel **12** to provide whole blood thereto for processing.

          To return separated blood components to cassette assembly **14**, the blood inlet/blood  
30           component tubing assembly **60** further includes red blood cell (RBC)/plasma outlet tubing, platelet outlet tubing and plasma outlet tubing interconnected with corresponding outlet ports on blood processing vessel **12**. The red blood cell (RBC)/plasma outlet tubing channels the separated red blood cell (RBC)/plasma component through cassette assembly **14** to red blood cell collection tubing assembly **70** through first decontamination system **72**. The platelet  
35           outlet tubing channels separated platelets through cassette assembly **14** to platelet collection tubing assembly **80** through second decontamination system **82**. The plasma outlet tubing channels separated plasma through cassette assembly **14** to plasma collection tubing

assembly **90** through third decontamination system **92**. After irradiation in the decontamination systems **72**, **82** and **92**, to activate the photosensitizer and inactivate microorganisms present, the blood components are collected in red blood cell collection bag **74**, platelet collection bags **84**, and plasma collection bag **94**. Vent bag **104** may be used to vent gases within the system. The plasma level of the fluids may be adjusted at any convenient point in the process.

Figure 7 depicts a stand-alone version of the decontamination assembly of this invention. Blood product **180** (which may be recently collected blood or blood component or stored blood) is connected to blood product line **186** which leads through pump **184** to decontamination cuvette **164**. Photosensitizer reservoir **166** is connected to photosensitizer input line **168** equipped with input pump **170**, and leads into blood product line **186** upstream from decontamination cuvette **164**. Decontamination cuvette **164** is a photopermeable cuvette of a depth (d) and a length (l) selected to ensure decontamination. Cooling system **190** combined with temperature monitor **192** are connected with decontamination cuvette **164** for controlling the temperature of the fluid. Decontamination cuvette **164** is connected via light guide **162** to photoradiation source **160**. A photoradiation enhancer **163** is placed adjacent to (either touching or spaced apart from) decontamination cuvette **164** to increase the amount of photoradiation reaching the blood product in the cuvette. Decontaminated blood product line **188** leads from decontamination cuvette **164** to decontaminated blood product collection **182**.

In operation, blood product **180** is conducted into blood product line **186** where it is joined by photosensitizer from photosensitizer reservoir **166** flowing at a rate controlled by photosensitizer input pump **170** in photosensitizer input line **68** which joins blood product line **186**. The flow rate in blood product line **186** is controlled by pump **184** to a rate selected to ensure decontamination in decontamination cuvette **164**. Temperature monitor **192** measures the temperature of fluid in cuvette **164** and controls cooling system **190** which keeps the temperature in the cuvette within a range required for optimal operation. The blood product in decontamination cuvette **164** is irradiated by photoradiation from photoradiation source **160** conducted in light guide **162**. The photoradiation source may comprise two or more actual lights. The arrows indicate photoradiation from the end of light guide **162** propagating in the blood product inside transparent decontamination cuvette **164**. Adjacent to decontamination cuvette **164** is photoradiation enhancer **163** which may be an additional source of photoradiation or a reflective surface. The arrows from photoradiation enhancer **163** pointing toward decontamination cuvette **164** indicate photoradiation from photoradiation enhancer **163** shining on the blood product material in cuvette **164**.

Decontaminated blood product exits decontamination cuvette **164** via decontaminated blood product line **188** and is collected at decontaminated blood product collection **182**.

In one embodiment using 7,8-dimethyl-10-ribityl isoalloxazine from Sigma Chemical Company as the photosensitizer, a light guide from EFOS Corporation, Williamsville, N.Y. composed of optical fibers is used. The system is capable of delivering a focused light beam with an intensity of 6,200 mW/cm<sup>2</sup> in the region of 355-380 nm. It is also possible to use interchangeable filters with the system to achieve outputs of 4,700 mW/cm<sup>2</sup> in the spectral region of 400-500 nm. In both cases, the output of light in the region of 320 nm and lower is negligible. Light guides of varying dimensions (3, 5 and 8 mm) are available with this system. The light exits the light guide tip with a 21 degree spread. The 8 mm light guide is appropriate, correctly placed, to adequately illuminate the face of the preferred decontamination cuvette which is a standard cuvette used on GAMBRO Spectra<sup>®</sup> disposables sets from Industrial Plastics, Inc., Forest Grove, OR.

The flow rate is variable and is determined by the amount of light energy intended to be delivered to the sample. The flow rate is controlled by means of a peristaltic pump from the Cole-Parmer Instrument Company, Vernon Hills, IL. Flow rates and type of input stream may be controlled via a computer processor as is known to the art.

Figure 23 depicts an embodiment of this invention in which fluid to be decontaminated is placed in a blood bag **284** equipped with an inlet port **282**, through which photosensitizer in powder or solution form **284** is added from flask **286** via pour spout **288**. The fluid may have had the plasma reduced prior to inlet into the bag, the bag may contain appropriate dilution solutions, the appropriate diluting solutions may be added to the bag after the fluid has been added, or the level of plasma may be reduced by any other means. Shaker table **280** is activated to agitate the bag **284** to mix or dissolve photosensitizer **290** while photoradiation source **260** is activated to irradiate the fluid and photosensitizer in bag **284**. Alternatively, the bag can be provided prepackaged to contain photosensitizer and any desired additives and the fluid is thereafter added to the bag.

The methods of this invention do not require the use of enhancers such as "quenchers" or oxygen scavengers, however these may be used to enhance the process by reducing the extent of non-specific cell or protein-damaging chemistry or enhancing the rate of pathogen inactivation. Further preferred methods using non-toxic endogenous photosensitizers and endogenously-based derivative photosensitizers do not require removal of photosensitizers

from the fluid after photoradiation. Test results show little or no damage to other blood components, e.g. platelets remain biologically active five days post-treatment.

Effect of lower plasma content on microorganism inactivation

5 Human blood platelets are typically stored at 20-24°C under gentle agitation in a gas permeable plastic container. The platelets are typically suspended in autologous plasma which may be supplemented with various formulations of additive solutions which provide nutrients, buffers and essential salts. Under these conditions, platelets may be held for 5 days or more before transfusion to a patient. Over the course of this storage period, all platelets  
10 undergo a deterioration in their metabolic status (indicated by the use of fuels and oxygen, and accumulation of lactic acid), and deterioration of their functional capacity as indicated by the loss or response to agonists, release of storage vesicles, appearance of neo-activation antigens on the plasma membrane, loss of plasma membrane molecular receptors, loss of lipid asymmetry, and/or appearance of microparticles. Previous efforts to minimize the in  
15 vitro damage to platelets and maintain their full functional capacity over time have been: change in storage temperature from 4°C to 22°C, use of storage containers with improved gas permeability for O<sub>2</sub> entry and CO<sub>2</sub> egress, exogenous fuel sources such as activation signal pathways with chemicals such as PGE<sub>1</sub> and cytochalasin, and light crosslinking of the cell with fixatives such as paraformaldehyde.

20 Lower plasma content in the microorganism inactivation methods of the invention improves the kinetics of microorganism inactivation and the cell quality because, for example, the time of irradiation and the light dose applied is reduced, and the need for ultraviolet light is reduced. Blood or blood components having lowered plasma content  
25 treated by the methods of this invention also have an enhanced storage time over blood or blood components that do not have lower plasma content.

In deactivation processes using photoactivated riboflavin, it has been determined that a large percent, typically about forty percent of riboflavin added to whole blood binds to  
30 plasma. This results in less riboflavin available to perform inactivation functions. Addition of more riboflavin to the sample does not provide more available riboflavin in a linear manner, due to at least two competing effects. First, the binding sites on the plasma cannot be saturated in whole blood and second, internal quenching of riboflavin occurs. Internal  
35 quenching occurs when the free riboflavin concentration causes an increase in the optical density of the solution.

With high protein concentrations, visible light activation of riboflavin yields a constant but relatively low level of inactivation of microorganisms. Addition of more visible light does not produce any additional inactivation because the riboflavin has been converted to lumichrome, which does not absorb visible light. Addition of ultraviolet light will produce additional inactivation, due to activation of lumichrome. However, as described elsewhere, ultraviolet light damages mitochondria and cell membranes. If the plasma content of a solution is decreased, visible light activation alone will produce a large inactivation without the use of ultraviolet light.

The preferred parameters for inactivating microorganisms in fluids including wavelength of activation, light dose, photosensitizer concentration and plasma percentage vary depending on the composition of the fluid being treated. Methods for optimizing these parameters for a given fluid composition are given herein, or known to those of ordinary skill in the art without undue experimentation.

To inactivate microorganisms in red blood cells with riboflavin as the photosensitizer, it is preferred that a wavelength range of between about 420 and about 500 nm is used. The most preferred wavelength is about 470 nm. Riboflavin in a concentration range of between about 50 and about 150 micromolar is preferred, with a concentration of about 100 micromolar most preferred for the preferred plasma content. A plasma content of between about 0 and about 50 percent of the total volume of the fluid is preferred, with a plasma content less than 20 percent by volume more preferred, with a plasma content less than about 10 percent of the total volume of the fluid being most preferred. The use of a storage and dilution solution such as CPD (Fenwal Labs, Deerfield, IL) or AS-1,2,3 (Fenwal Labs, Deerfield, IL) is preferred. A light intensity range of between about 40 and 100 mW/cm<sup>2</sup> of visible light is preferred, with as high a light intensity as possible being most preferred. 100 to 500 J/cm<sup>2</sup> of light is preferred, with 50 to 200 J/cm<sup>2</sup> being most preferred. A sufficient level of additives may be added to the fluid so that one or more components present in said fluid remain biologically active after exposing the fluid to photoradiation. The components of various diluting solutions and additive solutions are shown in the following tables.



	Molecular Weight	PAS II		PSM1-pH		PlasmaLyte A	
		Concentration (mMol/L)	g/300 mLs	Concentration (mMol/L)	g/300 mLs	Concentration (mMol/L)	g/300 mLs
Sodium Chloride	58.44	115.5	2.02	98	1.72	90	1.58
Potassium Chloride	74.55		0.00	5	0.11	5	0.11
Calcium Chloride	111		0.00		0.00		0.00
Magnesium Chloride	95.21		0.00		0.00	3	0.09
Magnesium Sulfate	120.4		0.00		0.00		0.00
Tri-Sodium Citrate	294.1	10	0.88	23	2.03	23	2.03
Citric Acid	192.1		0.00		0.00		0.00
Sodium Bicarbonate	84.01		0.00		0.00		0.00
Sodium Phosphate	142		0.00	25	1.07		0.00
Sodium Acetate	82.03	30	0.74		0.00	27	0.66
Sodium Gluconate	218.1		0.00		0.00	23	1.50
Glucose	180.2		0.00		0.00		0.00
Maltose	360.3		0.00		0.00		0.00
Total Mass (grams)			3.65		4.92		5.97

Note: Assumes that all salts are anhydrous

	Molecular Weight	SetoSol		PAS III		PAS	
		Concentration (mMol/L)	g/300 mLs	Concentration (mMol/L)	g/300 mLs	Concentration (mMol/L)	g/300 mLs
Sodium Chloride	58.44	90	1.58	77	1.35	110	1.93
Potassium Chloride	74.55	5	0.11		0.00	5.1	0.11
Calcium Chloride	111		0.00		0.00	1.7	0.06
Magnesium Chloride	95.21	3	0.09		0.00		0.00
Magnesium Sulfate	120.4		0.00		0.00	0.8	0.03
Tri-Sodium Citrate	294.1	17	1.50	12.3	1.09	15.2	1.34
Citric Acid	192.1		0.00		0.00	2.7	0.16
Sodium Bicarbonate	84.01		0.00		0.00	35	0.88
Sodium Phosphate	142	25	1.07	28	1.19	2.1	0.09
Sodium Acetate	82.03	23	0.57	42	1.03		0.00
Sodium Gluconate	218.1		0.00		0.00		0.00
Glucose	180.2	23.5	1.27		0.00	38.5	2.08
Maltose	360.3	28.8	3.11		0.00		0.00
Total Mass (grams)			9.29		4.66		6.68

*Note: Assumes that all salts are anhydrous*

Anticoagulant Preservative Solutions

	CPD			CP2D			CPDA-1		
	Conc. (mMol/L)	mg/63 ml	mg/100 ml	Conc. (mMol/L)	mg/63 ml	mg/100 ml	Conc. (mMol/L)	mg/63 ml	mg/100 ml
Sodium Citrate	89.59	1660.00	2634.92	89.59	1660.00	2634.92	89.59	1660.00	2634.92
Citric Acid	15.53	188.00	298.41	15.53	188.00	298.41	15.53	188.00	298.41
Dextrose	141.82	1610.00	2555.56	283.64	3220.00	5111.11	177.05	2010.00	3190.48
Monobasic Sodium phosphate	18.52	140.00	222.22	18.52	140.00	222.22	18.52	140.00	222.22
Adenine	0.00	0.00	0/00	0.00	0.00	0.00	2.03	17.30	27.46
<b>Total Mass (grams)</b>		<b>3.60</b>	<b>5.71</b>		<b>5.21</b>	<b>8.27</b>		<b>4.02</b>	<b>6.37</b>

Additive Solutions

	Molecular Weight	AS-1 (Adsol)		AS-3 (Nutricel)		AS-5 (Optisol)		SAGM		MAP	
		Conc. (mMol/L)	mg/100 ml	Conc. (mMol/L)	MG/100ml	Conc. (mMol/L)	mg/100ml	Conc. (mMol/L)	mg/100 ml	Conc. (mMol/L)	mg/100 ml
Dextrose	180.2	122.09	2200.00	61.04	1100.00	49.94	900.0	49.94	900.00	0.00	0.00
Adenine	135.1	2.00	27.00	2.22	30.00	2.22	30.00	1.25	16.90	0.10	1.30
Monobasic Sodium phosphate	120	0.00	0.00	23.00	276.00	0.00	0.00	0.00	0.00	7.80	93.60
Mannitol	182.2	41.16	750.00	0.00	0.00	28.81	525.00	28.81	525.00	79.91	1456.00
Sodium Chloride	58.45	153.98	900.00	70.15	410.00	150.04	877.00	150.04	877.00	85.03	497.00
Sodium Citrate	294.1	0.00	0.00	19.99	588.00	0.00	0.00	0.00	0.00	6.00	176.40
Glucose	180.2	0.00	0.00	0.00	0.00	0.00	0.00	0.00	0.00	39.96	720.00
Citric Acid	192.1	0.00	0.00	2.19	42.00	0.00	0.00	0.00	0.00	0.00	0.00
<b>Total Mass (grams)</b>			<b>3.88</b>		<b>2.45</b>		<b>2.33</b>		<b>2.32</b>		<b>2.94</b>

Anticoagulants for Apheresis		ACD-A		ACD-B	
		Molecular Weight	Conc. (mMol/L)	mg/100 ml	Conc. (mMol/L)
Dextrose	180.2	135.96	2450.00	81.58	1470.00
Adenine	135.1	0.00	0.00	0.00	0.00
Monobasic sodium phosphate	120	0.00	0.00	0.00	0.00
Mannitol	182.2	0.00	0.00	0.00	0.00
Sodium Chloride	58.45	0.00	0.00	0.00	0.00
Sodium Citrate	294.1	74.80	2200.00	44.88	1320.00
Citric Acid	192.1	41.64	800.00	24.99	480.00
<b>Total Mass (grams)</b>			<b>5.45</b>		<b>3.27</b>

It is preferred that a wavelength range of between about 400 and about 500 nm is used to inactivate the microorganisms in a solution consisting mainly of platelets. The most preferred wavelength is 419 nm. Riboflavin in a concentration range of between about 10 and about 30 micromolar is preferred, with a concentration of about 10 micromolar most preferred when a preferred level of plasma is present. A plasma content of between about 0 and about 50 percent of the total volume of the fluid is preferred, with a plasma content less than 25 percent by volume more preferred, with a plasma content less than about 15 percent of the total volume of the fluid being most preferred. It is preferred that platelets be stored and diluted in a solution such as SETO-sol (Terumo) or PASIII (Fenwal Labs, Deerfield, IL). A light intensity range of between about 40 and 100 mW/cm<sup>2</sup> of visible light is preferred, with as high a light intensity as possible being most preferred. A light dose of between about 100 and about 500 J/cm<sup>2</sup> is preferred, with between about 100 and about 200 J/cm<sup>2</sup> most preferred. A sufficient level of additives may be added to the fluid so that one or more proteins present in said fluid remains biologically active.

It is preferred that a wavelength range of between about 300 and about 500 nm is used to inactivate the microorganisms in fluid consisting mainly of plasma. Both ultraviolet and visible light is currently required. It is presently preferred that a combination of 365, 419 and 447 nm be used. A plasma content between about 50 and 100 percent of the total volume of said fluid is preferred, with a plasma content of about 90 percent of the total volume of said fluid being currently most interesting. A sufficient level of additives may be added to the fluid so that one or more protein present in said fluid remains biologically active after said exposing step. Riboflavin in a concentration range of between about 10 and about 100 micromolar is preferred, with a concentration of about 50 micromolar most preferred for a fluid with the preferred level of plasma. If the plasma is diluted, it is preferably diluted in 0.9% saline. A light intensity of between about 80 and 100 mW/cm<sup>2</sup> of visible + ultraviolet light is preferred, with as high a light intensity as possible being most preferred. A light dose of 100 to 500 J/cm<sup>2</sup> of light is preferred, with 100 to 200 J/cm<sup>2</sup> being most preferred.

#### Apparatus design.

The methods of the invention may be used in a variety of devices. The devices generally comprise: a light source producing light having sufficient wavelength and power to induce inactivation of microorganisms which may be present in a sample; and means for positioning the sample so that it receives energy of sufficient wavelength and power to induce inactivation of microorganisms.

The system preferably includes means for producing<sup>4</sup> movement in the sample. Movement provides many benefits including improving the efficiency of the inactivation reactions by helping mix the photosensitizer with the fluid to be deactivated and providing turnover of sample at the container-light interface, for example. An agitator, such as a Helmer flatbed agitation system (Helmer) may be used. This agitator provides oscillatory motion. Other types of agitators may be used to provide motion normal to the bag. If a bag is used as a container, in combination with a source of movement, a pin or other structure may be placed across or within the bag to provide turbulent eddies in the fluid. The agitator may be connected to a computer or other controller in an inactivation system. Some parameters that may be controlled or monitored include temperature of the fluid, energy output of the lights, agitation motion, light control, timing control or monitoring, and other parameters. The light source and fluid being treated may both move to provide agitation of the fluid, or only the fluid being treated may move while the light source remains stationary.

One particular embodiment of the apparatus is an enclosed photoradiation system where the sample would be placed in an apparatus similar to the Bio-Genic irradiator (Vilber-Lourmat, Cedex, France) that uses the appropriate wavelength or wavelengths. Another embodiment is a conveying apparatus used in a large-scale operation to carry samples through a light field or series of light fields.

Means for positioning the sample so that it receives energy of sufficient wavelength and power to induce inactivation of microorganisms include a shelf or tray for the sample to be disposed upon; a gap between two supports which may be a light or light arrays, where the sample is positioned between the supports; or other means as known in the art. The shelf or tray may move, as in a conveyer line. Fluid-holding shelves may be transparent to one or more of the wavelength(s) of light applied.

The sample may be placed in a suitable container on a support surface between two or more sources of photoradiation, like a sandwich. Alternatively, one of the photoradiation-sources may be a reflective material, to allow the light to contact both sides of the sample. Alternatively, or in combination, the sample may be placed on a support and light may impinge on one surface, with agitation, to allow different portions of the sample to be in contact with the light.

Different sources of photoradiation may be used, depending on the wavelength desired and the power desired at the desired wavelength.

Some examples of light sources that may be used include the following. A 20 watt Philips "Blacklight" F20T12/BL emits wavelengths from about 350 nm to about 400 nm. A Philips "Special Blue" F20T12/BB 20 watt light emits wavelengths from about 400 to 500 nm. Ultraviolet Resources International's URI FR20T12 super actinic/VHO-1 CE U123 lamp emits wavelengths from about 400 nm to about 450 nm. Custom Sea Life "Power Compact" 7100K Blue 28 watt Twin Tube emits wavelengths from about 400 nm to about 520 nm. The Sylvania "Blue" F20T12B 20 watt bulb has a broad emission from about 400 nm to about 640 nm. Other representative light sources that may be used include the Armatron "Bug Lights" BF190 8077 Black Light. Mercury lamps may also be used, and have a spectral range from about 300 nm to about 400 nm. Lamps used in tanning booths generally have a spectral range from about 300 to 400 nm. Super Actinic lamps generally have a spectral range from about 400 to about 440 nm, with a peak at 420 nm. Bilirubin lights used to treat infants suffering from jaundice may also be used. For example, a light from Philips Lighting having a peak output at 447 nm and a range of about 420-460 nm may be used.

Lights that emit in the blue spectral range come from various sources. Lamps with peak emissions around 420 to 450 nm may be purchased from LCD Lighting, Orange, CT; Bulbtronic, Farmingdale, NY; National Biological Corp., Twinsburg, OH; The Fluorescent Co., Saugus, CA; Tek-West, Los Angeles, CA; or Southern NE UV, Bransford, CT, for example. LED (light emitting diodes) may also be used. These LEDs may use a variety of materials to produce the desired spectral output, including silicon carbide (bandwidth around 100 nm; peak spectral output near 466nm) or gallium nitride (bandwidth around 30 - 35 nm; peak spectral output near 470nm). Also, lights made from a combination of different materials can generate different wavelengths of light. For example, gallium nitride on a silicon carbide substrate can generate 430 nm. These LEDs are manufactured or distributed by Panasonic, Chicago Miniature, Nichia, Toyoda Gosei, Hewlett Packard, LEDTronics, for example. LED lights typically do not require any outside cooling.

The lights may be used in different ways, depending the particular apparatus. For example, diodes may be duty cycled to emit light when the sample arrives in a flow cell light path. Arrays of diodes may surround the fluid in any desired configuration. In a flat bed apparatus, light arrays may surround the fluid from top or bottom, or both.

Filters, such as color glass filters, may be used to isolate a desired band of the spectrum. Single wavelength or narrow band sources may also be used.



One embodiment of an apparatus useful in the methods of the invention includes banks of interchangeable lights that produce the desired wavelength of light for the particular fluid being treated. Preferred embodiments include using a HID light source to produce 365 nm light that is useful to inactivate microorganisms in plasma. An HID light source is high intensity discharge. A super actinic lamp or a blue LED may be used to produce 419 nm light that is useful in inactivating microorganisms in platelets. A coral or aquarium light may be used to produce wavelengths between 440 and 470 nm that is useful in inactivating microorganisms in red blood cells. The lamps may be provided with separate power supplies to control the level of light output. These lamps may be sequentially placed in position to impinge light on the sample, or the sample may travel through lights of different wavelengths. Different LEDs emitting each desired wavelength may be combined in one array.

Active (cooling through some applied means) or passive (air cooling) cooling may be used if necessary to cool either the lamps or the blood. Fans may provide cooling. One set of fans may be used to cool both the lamps and blood, or different fans may be used to provide different levels of cooling to both the lamps and the blood. A photopermeable fluid may surround the sample and/or lights to provide active cooling. This fluid may be optionally temperature controlled.

## EXAMPLES

### Example 1 Absorbance Profile of 7,8-dimethyl-10-ribityl isoalloxazine

A sample of 7,8-dimethyl-10-ribityl isoalloxazine (98% purity) was obtained from Sigma Chemical Company. A portion of this sample was submitted for analysis using a scanning UV spectrophotometer. The range studied covered the region of 200 to 900 nm. For analysis, the sample was dissolved in distilled water. A sample spectrum from this analysis is shown in Figure 1.

Results were consistent with those reported in the literature for the absorbance maxima and extinction coefficients for 7,8-dimethyl-10-ribityl isoalloxazine

<u>Literature <math>\lambda_{\max}</math> (<math>\epsilon</math>)</u>	<u>Measured <math>\lambda_{\max}</math> (<math>\epsilon</math>)</u>
267 (32,359)	222 (30,965) 265 (33,159)
373 (10,471)	373 (10,568)
447 (12,303)	445 (12,466)

Appropriate wavelengths for irradiation are 373 and 445 nm. The extinction coefficients observed at these absorbance maxima is sufficient to ensure adequate activation of the sensitizer in solution.

5 Example 2 Solubility of 7,8-dimethyl-10-ribityl isoalloxazine  
Solubility in Isolyte S, pH 7.4 Media

The maximum solubility of 7,8-dimethyl-10-ribityl isoalloxazine in Isolyte S media was determined as follows:

10 7,8-dimethyl-10-ribityl isoalloxazine was mixed with Isolyte S until a precipitate was formed. The mixture was agitated at room temperature for one hour and vortex mixed to ensure complete dissolution of the suspended material. Additional 7,8-dimethyl-10-ribityl isoalloxazine was added until a solid suspension remained despite additional vortex mixing. This suspension was then centrifuged to remove undissolved material. The supernatant from  
15 this preparation was removed and analyzed using a spectrophotometer. The absorbance values of the solution were determined at 447 nm and 373 nm. From the extinction coefficients that were determined previously, it was possible to estimate the concentration of the saturated solution

$$\text{Concentration (373)} = 110 \mu\text{M} = 42 \mu\text{g/mL}$$

20  $\text{Concentration (447)} = 109 \mu\text{M} = 40.9 \mu\text{g/mL}$

Solubility in ACD-A Anticoagulant

The same procedure described above was repeated using ACD-A Anticoagulant. The values obtained from these measurements were as follows:

25  $\text{Concentration (373)} = 166 \mu\text{M} = 63 \mu\text{g/mL}$

$$\text{Concentration (447)} = 160 \mu\text{M} = 60.3 \mu\text{g/mL}$$

The values obtained from these studies indicate an upper limit of solubility of the compound that may be expected.

30 Example 3 Photodecomposition of 7,8-dimethyl-10-ribityl isoalloxazine in Aqueous  
Media

A solution of 7,8-dimethyl-10-ribityl isoalloxazine in Sigma ACD-A was prepared at a concentration of 63  $\mu\text{g/mL}$ . This preparation was taken up into a glass pipette and placed in the path of a UV light source (365 nm  $\lambda_{\text{max}}$  with filters to remove light below 320 nm). The  
35 suspension was irradiated for specific intervals at which aliquots were removed for spectroscopic analysis. The absorbance of the dissolved 7,8-dimethyl-10-ribityl isoalloxazine

was monitored at 373 and 447 nm at each time interval. The results are depicted in Figure 3 and Table 1.

Table 1. Photodecomposition of 7,8-dimethyl-10-ribityl isoalloxazine  
Upon Exposure to UV Light (365 nm) in Acid Solution

Irradiation Time	% of Initial, 373 nm	% of Initial, 447 nm
0	100	100
5	87.3	61.6
10	90.5	76.6
15	100	70

The absorption profile for the solution at 373 nm indicates that no significant decomposition of the reagent occurred over the entire irradiation period. The absorbance of light at this wavelength corresponds to  $n-\pi^*$  electronic transitions. The absence of a decrease in the intensity of this peak over time indicates that the ring structure of the molecule is intact despite prolonged irradiation under these conditions. The absorbance of the molecule at 447 nm is due to  $\pi-\pi^*$  electronic state transitions. The decrease in the absorbance of the molecule at this wavelength with increasing irradiation times is indicative of subtle alterations in the resonance structure of the molecule. This change is most likely due to the loss of ribose from the ring structure of the 7,8-dimethyl isoalloxazine backbone and the formation of 7,8-dimethylalloxazine as a result. These changes are consistent with literature reports on the behavior of the molecule upon irradiation with UV light.

The apparent lack of decomposition of the ring structure of the molecule is in stark contrast to observations with psoralen based compounds under similar conditions. During irradiation, a significant fluorescence of the molecule in solution was observed. This behavior of the molecule is consistent with the resonance features of the ring structure and provides a means for the dissipation of energy in the excited state molecule in a non-destructive fashion.

Example 4 Flow System Concept Evaluation  
Light Transmission Properties of Existing Spectra Cuvette

5 The existing Spectra cuvette is composed of polycarbonate. The light transmission properties of this cuvette were measured at 373 and 447 nm by placing the cuvette in the light path of a UV spectrophotometer. The values obtained were as follows:

	<u>Wavelength of Light</u>	<u>% Transmittance</u>
	373 nm	66%
10	447 nm	80%

15 These results are consistent with those reported in the literature for polycarbonate plastics (see Figure 4). The literature values indicate a steep shoulder for the transmission of light through polycarbonates in the region of 300 nm. For the region above 350 nm, the light transmission properties are adequate for this application.

Light Flux Requirements Calculated as a Function of Flow Rates

20 In order for a flow system to be feasible, the sample must be provided with an adequate flux of light during its presence in the beam path. If the proposed Spectra cuvette were to serve this purpose, then it is possible to estimate the light flux requirements as a function of flow rates through the cuvette as follows:

The volume of solution present in the irradiation zone of the cuvette is ca. 0.375 mls. The transit time for a cell in this region of the cuvette can be determined from the following equation:

$$25 \quad T = \frac{\text{Volume of Cuvette (mls)}}{\text{Flow Rate (mls/min)}}$$

At 100 mls per minute, the transit time (T) would be 0.00375 min = 0.225 seconds.

30 The energy to which a sample is exposed is dependent on the flux according to the following equation:

$$35 \quad \text{Energy (E, Joules/cm}^2\text{)} = \frac{\text{Flux } (\phi, \text{ mW/cm}^2\text{)} * \text{Time (T, sec.)}}{1000}$$

If we assume that 1 Joule/cm<sup>2</sup> is required to activate the sensitizer adequately and the transit time (T) is 0.22 seconds (i.e., flow rate of 100 mls/min through the cuvette), then the required Flux during the sample's transit through the cuvette is 4,545 mW/cm<sup>2</sup>. A graph

depicting the relationship of the required flux from the light source to flow rates through the cuvette is provided in Figure 5.

5 These results indicate that, for a flow system to operate properly, UV sources with outputs in the region of Watts/cm<sup>2</sup> are required.

Figure 2 shows how absorbance should vary with concentration of platelets.

#### Example 5 Absorbance of Red Blood Cells.

10 In order to evaluate the extent to which UV light can penetrate a red cell sample and the effects of sample thickness and hematocrit on the extent of light penetration, several preliminary experiments were carried out using chemical actinometry, a method for determining the actual amount of light intensity emanating from a source by measuring the ability and extent to which absorbed light can effect a chemical reaction. For these studies, a  
15 ferrioxalate solution was utilized in order to measure the source intensity relative to that observed for water. Details of the chemical reaction and the methods utilized for sample preparation are as taught in Gordon, A.J. and Ford, R.A. (1972), "The Chemist's Companion: Handbook of Practical Data, Techniques and References" (John Wiley & Sons), pp. 362-368.

20 Samples of iron (III) oxalate were prepared in the test material (water or blood product at varying red cell hematocrits) at a concentration of 0.15 M. These samples were then loaded into a standard Spectra cuvette and placed in the irradiation assembly. Samples were exposed for pre-determined time intervals corresponding to the desired energy dose level (1 J/cm<sup>2</sup>). The samples were then removed and the amount of conversion of Fe<sup>3+</sup> to Fe<sup>2+</sup> was determined by reading the absorbance of the test article in a 1,10-phenanthroline solution at 510 nm as described in Gordon, A.J. and Ford, R.A., *supra*. Higher absorbance values are indicative of greater light penetration into the sample. The absorbance value observed for water after exposure to 1 J/cm<sup>2</sup> UV radiation was used as the 100%  
25 Transmittance level. All values for red cell samples were determined relative to this standard.  
30

Table 2. Absorbance Readings After Exposure of Samples to a  $1 \mu\text{cm}^2$  UVA Light  
 All Average Values Represent the Mean of 6 Experiments.  
 % Transmittance Values Are Calculated Relative to Water Samples.

Absorbance at 510 nm	Average	Standard Deviation	% Transmittance	Standard Deviation
Water	2.40	0.04	100	0.0
RBC, 1.3% Hematocrit	2.40	0.10	99.5	4.8
RBC, 3.7% Hematocrit	1.46	0.38	60.6	15.4
RBC, 5.07% Hematocrit	0.20	0.26	8.3	10.8
RBC, 6.0% Hematocrit	0.13	0.09	5.2	3.9
RBC, 10.2% Hematocrit	0.23	0.19	9.7	7.9
RBC, 16.3% Hematocrit	0.25	0.11	10.4	4.6
RBC, 21.8% Hematocrit	0.09	0.06	3.6	2.6
RBC, 80.2% Hematocrit	0.01	0.11	0.3	4.4

5

Using these values, it is possible to calculate the penetration depth of UV light by using Beer's Law ( $A = \epsilon b C$ ).

From Lambert's Law,

10

$$\text{Absorbance} = \text{Log} (1/\text{Transmittance})$$

If we let the concentration (C) be equal to the hematocrit of the sample, and since  $b = 0.3$  cm (the path length of the Spectra cuvette), then it is possible to determine a pseudo-extinction coefficient for the samples ( $\epsilon'$ ) by plotting the absorbance values for the red cell samples versus the product of the hematocrit times the path length. The extinction coefficient for the samples is represented by the slope of this line.

15

Table 3: Determination of Extinction Coefficient for Red Cell Samples.

T	B	HCT	B*HCT	Absorbance log (1/T)	$\epsilon$
0.995	0.3	1.3	0.39	0.002	.0051
0.606	0.3	3.7	1.11	0.218	.196
0.0525	0.3	6	1.8	1.280	.71
0.097	0.3	10.2	3.06	1.013	.33
0.104	0.3	16.3	4.89	0.983	.20
0.036	0.3	21.8	6.54	1.444	.22
0.0033	0.3	80.2	24.06	2.481	.10

Using the values obtained as described above, it was possible to determine a pseudo-extinction coefficient for these samples to be 0.08661.

The value for the extinction coefficient permits calculation of the penetration distance of UV light into red cell samples as a function of the sample hematocrit. For this estimation, the penetration depth of the sample in which 90% of the incident light would be absorbed was determined using the following equation:

$$A = \epsilon b C$$

A = 1 (90% Absorbance of Incident Light),  $\epsilon = 0.08661$ , C = Sample hematocrit, b = Path Length.

The values determined using actinometry were compared to those which were calculated previously using estimates taken from UV Spectrophotometric measurements of light absorbance in red cell and platelet samples.

Figure 2 shows how absorbance and distance from the light source varies for red blood cells, comparing predicted with observed values. These results indicate that, for samples at hematocrits in the region of 80%, it is possible, using the preferred configuration of this invention, to get light into the sample to a depth of 0.14 cm. This represents a flow path width that is less than half the width of the current Spectra cuvette.

#### Example 6 Effects of Virus Inactivation Treatment on Platelet *In Vitro* Parameters.

Effects of virus inactivation treatment on platelet *in vitro* parameters were evaluated. Platelet preparations were treated with 7,8-dimethyl-10-ribityl isoalloxazine in combination with UV light. Various *in vitro* parameters were used as monitors of platelet function in

order to determine the extent of changes induced by the treatment conditions. Factors such as energy level of UV light exposure, dose of 7,8-dimethyl-10-ribityl isoalloxazine used, and sample processing conditions were examined for their impact on platelet quality post-treatment. Results from this study are used to establish an appropriate treatment window for inactivation of HIV-1 without compromising platelet function.

Samples were prepared with three different concentrations of 7,8-dimethyl-10-ribityl isoalloxazine. Platelets obtained from a standard Spectra LRS collection were used for these studies.

Starting samples were centrifuged to concentrate the platelet pellet. The pellet was resuspended in a 70:30 (Isolyte S, pH 7.4; McGaw, Inc. Media:Plasma) solution. 7,8-dimethyl-10-ribityl isoalloxazine at the specified concentration, was present in the plasma:media mixture. The platelet suspension was then passed through a UV irradiation chamber at one of three specified flow rates. The flow rates were directly correlated to the energy level of exposure for the cells/media mixture which passes through the irradiation chamber. After flowing through the irradiation chamber, samples were stored in a citrate plasticized sampler bag for subsequent analysis.

Following irradiation, *in vitro* measurements of platelet function, including hypotonic shock response (HSR), GMP-140 expression, pH, pCO<sub>2</sub>, pO<sub>2</sub>, platelet swirl, and cell count, were evaluated in order to determine the effects of the treatment protocol on cell quality.

Platelet quality was monitored as a function of irradiation conditions (sensitizer concentration and flow rates/Energy levels). The platelet quality includes parameters such as HSR response, GMP-140 activation, etc. The flow rates that are studied can be related to the Energy of exposure as follows:

$$\text{Transit Time (T, sec)} = \text{Exposure Time} = \frac{0.375 \text{ mls}}{(F_r/60)}$$

$F_r$  = Flow Rate (mls/min)

0.375 mls = Cuvette Volume (mls)

$$\therefore T \text{ (sec)} = \frac{22}{F_r}$$



$$\text{Energy (Joules/cm}^2\text{)} = \frac{\text{Flux } (\phi, \text{ mW/cm}^2\text{)} * \text{Time (sec)}}{1000}$$

5

$$E = \frac{\phi * 0.022}{F_r}$$

The effect of energy of UV exposure and concentration of 7,8-dimethyl-10-ribityl isoalloxazine on the stability and viability of treated platelets was evaluated. Three energy levels and three concentration levels were evaluated as follows:

10

Energy Levels: 1,5,9 J/cm<sup>2</sup>\*  
 7,8-dimethyl-10-ribityl isoalloxazine  
 Concentrations: 1, 50, 100 μM\*\*

15

\* Levels of total energy exposure were determined by the flow rate of the suspension through the irradiation chamber in accordance with the conversion chart of Table 4.

20

\*\* Since the media is diluted 70:30 (Media:Plasma) the stock concentration of 7,8-dimethyl-10-ribityl isoalloxazine in media alone prior to mixing with the plasma was adjusted appropriately. This required starting concentrations in Isolyte S of 1.43, 71.4, and 143 μM.

Table 4. Energy Exposure Levels as a Function of Flow Rate Through the Irradiation Chamber

Energy Delivered (J/cm <sup>2</sup> )	Flow Rate (mls/min)	Time to process 20 mls (minutes)
1	16.90	1.18
2	8.45	2.37
3	5.83	3.55
4	4.22	4.73
5	3.38	5.92
6	2.82	7.10
7	2.41	8.29
8	2.11	9.47
9	1.88	10.65
10	1.69	11.84

Flux = 3640 mW/cm<sup>2</sup>; chamber volume = 0.117 mls.

25

Values for treated samples were compared to control groups. The control samples included the following:

5                    Untreated Sample in Plasma (Historical Control)  
                      +Flow-UV-7,8-dimethyl-10-ribityl isoalloxazine

### Procedure

10                    A normal donor platelet apheresis product was obtained from an AABB accredited blood banking facility. The sample was collected using standard Spectra LRS procedures. All manipulations or procedures described below were performed with standard laboratory safety procedures and methods. The unit number and blood type were recorded. All samples were used within 24 hours of collection. Aseptic procedure was followed for all sample transfers and processing steps.

15                    The sample was transferred to a 500 mls PVC transfer pack and centrifuged at 5000 x g for five minutes to pack the platelets. Plasma was then removed from the platelet pellet using a standard plasma press. The plasma was retained for further use. The plasma removed from the cell pellet was then mixed with a stock solution of Isolyte S, pH 7.4; McGaw, Inc. This stock solution of media was prepared by adding a pre-determined amount of 7,8-dimethyl-10-ribityl isoalloxazine to Isolyte S to provide final concentrations of 1.43, 20                    71.4, and 143  $\mu\text{M}$ . Following addition of 7,8-dimethyl-10-ribityl isoalloxazine the stock solution was filtered through a 0.22  $\mu\text{M}$  sterile filter. The stock solution was then mixed with autologous plasma in a 70:30 (v:v) ratio to provide final 7,8-dimethyl-10-ribityl isoalloxazine concentrations of 1, 50, and 100  $\mu\text{M}$  respectively. During preparation of the 7,8-dimethyl- 25                    10-ribityl isoalloxazine stock solutions, care was taken to avoid exposure to light. Samples were prepared according as follows:

1 $\mu\text{M}$	2 samples
100 $\mu\text{M}$	2 samples
30                    50 $\mu\text{M}$	1 sample

35                    The platelet pellet was then resuspended in the plasma:media mixture to the original volume of the starting sample. The sample was connected to a flow apparatus comprising a container for cells and photosensitizer, a container for media, said containers being connected via valved lines to a single line for mixed cells/sensitizer and media equipped with a pump. Mixed cells/sensitizer and media were flowed into a cuvette held in a holder with a mirrored

wall, irradiated by a light source. This irradiation chamber was equipped with a temperature probe. After passing through the cuvette, fluid was collected in a product bag.

5 The tubing set was initially primed with Isolyte S media. Five minutes prior to the start of the test sample flow, the light source was activated. Temperature was monitored during this interval and kept lower than 32°C in the irradiation chamber.

10 The flow rate for the sample through the irradiation chamber was determined by the chart of Table 4. Flow rates which provide total irradiation energy levels of 1, 5 and 9 J/cm<sup>2</sup> were utilized according to the following testing matrix:

**Sample Run #1: 7,8-dimethyl-10-ribityl isoalloxazine Concentration = 1 µM**

- A. +7,8-dimethyl-10-ribityl isoalloxazine+ 1 J/cm<sup>2</sup>  
B. +7,8-dimethyl-10-ribityl isoalloxazine+ 9 J/cm<sup>2</sup>

15

**Sample Run #2: 7,8-dimethyl-10-ribityl isoalloxazine= 100 µM**

- A. + 7,8-dimethyl-10-ribityl isoalloxazine+ 1 J/cm<sup>2</sup>  
B. + 7,8-dimethyl-10-ribityl isoalloxazine+ 9 J/cm<sup>2</sup>

20

**Sample Run #3: 7,8-dimethyl-10-ribityl isoalloxazine= 50 µM**

- A. + 7,8-dimethyl-10-ribityl isoalloxazine+ 5 J/cm<sup>2</sup>

**Sample Run #4: Control Sample, 7,8-dimethyl-10-ribityl isoalloxazine= 0 µM**

- A. +Flow-UV-7,8-dimethyl-10-ribityl isoalloxazine

25

All samples were identified by the run number and sample letter designation corresponding to treatment condition (i.e., 1A). Each sample set was run for a total of 2 replicates. The order in which samples were treated was determined by assignment according to a random number generator.

30

A sample volume of 20 mls per run condition was collected for each sample. These samples were collected into citrate plasticized sampling bags (53 mls total volume) and stored for analysis. The temperature of the sample and the irradiation chamber was noted at the start, mid-point, and end of each run.

35

An initial aliquot from each preparation was removed post-treatment for analysis. Parameters for analysis included cell count, pH, pCO<sub>2</sub>, pO<sub>2</sub>, platelet swirl, HSR, and GMP-

140 analysis. The remaining portion of the sample was placed in an end-over-end platelet agitator in a +22 incubator and stored for five days post-treatment. On day 5, a second aliquot was removed and analyzed for the same *in vitro* parameters.

5 The following equipment was used: Nikon Labophot microscope; Serono-Baker System 9000 Hematology Analyzer; analytical balance; platelet incubator (+22 Celsius) and rotator; laboratory refrigerator (+4 Celsius); Mistral 3000i Centrifuge; Corning Blood Gas Analyzer; Becton-Dickinson FACSCALIBUR Flow Cytometer; UV irradiation chamber; UV radiometer (UVX Radiometer, UVP, Inc.); EFOS Ultracure 100SS Plus (365 nm maximum  
10 output and 340 nm bandpass filters); and temperature probe (thermocouple).

Results for each set of test variables were compared for the defined conditions of energy of exposure and concentration of 7,8-dimethyl-10-ribityl isoalloxazine. Direct comparison to the untreated control sample was made and significant differences defined by a  
15 probability  $p > 0.05$  from a paired, one-tailed, Student's T-Test analysis.

The results from these studies were summarized as follows:

4. At sensitizer concentrations in excess of 10  $\mu\text{M}$  and platelet concentrations above 1.5E+06/ $\mu\text{L}$ , there was a drop in sample pH by day 2. The pH declined steadily  
20 beyond day 2 of storage reaching unacceptable levels (<6.5) by day 3 of storage. All other *in vitro* parameters followed the pattern observed with sample pH.
5. This decrease in sample pH occurred regardless of whether or not the sample was exposed to UV light.  
25
6. At platelet concentrations of 5.4E+05/ $\mu\text{L}$ , there was no drop in sample pH after extended storage at any sensitizer concentration studied up to 100  $\mu\text{M}$ .
7. At sensitizer concentrations up to 10  $\mu\text{M}$ , platelet concentrations above 1.5E+06/ $\mu\text{L}$ ,  
30 and UVA levels up to 10  $\text{J}/\text{cm}^2$ , measured platelet properties were comparable to control, untreated cells. These remained comparable to control levels after five or more days of storage post-treatment.

35 These studies on platelet function post-treatment provided a clear window in which cell properties were maintained at levels comparable to untreated cells. The results also indicated that by varying the storage or treatment conditions for the cells this window can be expanded. The observed effect of 7,8-dimethyl-10-ribityl isoalloxazine with or without UV

light on sample pH suggests a metabolic effect of this additive which may be moderated by changes in the storage or processing conditions of the samples.

Example 7    Measurements of Shear Stresses on Red Cells As a Function of Flow Rate and Sample Hematocrit

The low levels of UV light penetration into red cell samples at high hematocrits raised the need to understand the effects of passing red cells through narrow openings in the light path. Reduction in sample thickness in the light path should increase delivery of UV dose at high sample hematocrits. In order to confirm this approach, several pressure drop measurements were undertaken using openings of varying dimensions. A pressure gauge was placed in line with a peristaltic pump both upstream and downstream from the narrowed openings. Whole blood of varying hematocrits was passed through the openings at controlled flow rates. Differences in the pressure readings at both locations permitted direct measurement of the pressure drop across the opening. Using this value and the dimensions of the opening, it was possible to determine the shear stress experienced by the red cells as they passed through the narrowed cell using the following equation:

$$\Delta P = \frac{8\mu l Q}{g d^3 w} \quad \text{Pressure Drop}$$

$$\tau_w = \frac{4\mu Q}{g w d^2} \quad \text{Shear Stress}$$

For blood,

$\mu$  = Viscosity = 0.0125/(1-Hematocrit)

$g$  = gravitational constant = 981

$Q$  = Flow Rate = mls/sec

$l, w, d$  = Dimensions of opening in cm

Table 5: Measurement of Shear Stress on Red Cells As Functions of Flow Rate and Sample Hematocrit

		0.08 X 0.008	Dp <sub>meas</sub> (dynes/c m <sup>2</sup> )	0.08 X 0010	Dp <sub>meas</sub> (dynes/c m <sup>2</sup> )	0.08 X 0.012	Dp <sub>meas</sub> (dynes/cm <sup>2</sup> )
41% HCT	Q=3.38	1.5	95.9	1.0	77.6	0.0	0.0
64% HCT	Q=3.38	4.0	255.8	3.0	232.9	2.0	182.1
41% HCT	Q=16.9	9.7	618.4	7.0	543.4	4.7	425.3
61% HCT	Q=16.9	20.7	1321.9	12.3	957.2	8.7	789.6

		0.10 X 0.008	Dp <sub>meas</sub> (dynes/c m <sup>2</sup> )	0.1 X 0.010	Dp <sub>meas</sub> (dynes/c m <sup>2</sup> )	0.1 X 0.012	Dp <sub>meas</sub> (dynes/cm <sup>2</sup> )
41% HCT	Q=3.38	2.0	93.7	1.0	60.3	1.0	73.5
64% HCT	Q=3.38	4.5	210.8	3.0	180.9	2.0	146.9
41% HCT	Q=16.9	12.7	593.6	7.0	422.1	4.7	343.0
61% HCT	Q=16.9	23.3	1093.0	14.7	884.6	12.0	881.4

		0.15 X 0.008	Dp <sub>meas</sub> (dynes/c m <sup>2</sup> )	0.15 X 0.010	Dp <sub>meas</sub> (dynes/c m <sup>2</sup> )	0.15 X 0.012	Dp <sub>meas</sub> (dynes/cm <sup>2</sup> )
41% HCT	Q=3.38	3.0	97.4	1.2	49.2	1.0	49.0
64% HCT	Q=3.38	6.5	211.0	3.5	143.5	2.0	97.9
41% HCT	Q=16.9	15.3	497.7	8.3	341.6	5.7	277.6
61% HCT	Q=16.9	35.7	1158.1	18.0	738.1	12.7	620.4

5

In previous experiments, it was determined that shear stresses of 1,000-2,000 dynes/cm<sup>2</sup> for intervals of 1-10 minutes or levels of 5,000-7,000 dynes/cm<sup>2</sup> for intervals of approximately 10 msec were sufficient to induce red cell hemolysis. Only in the case of the highest sample hematocrit (61%) and highest flow rate (16.9) did values exceed 1,000 dynes/cm<sup>2</sup>. This occurred only for openings of the narrowest width (0.008 inches).

10

Values for the light penetration depth using the proposed configuration indicate that delivery in sufficient UV energy to drive virus inactivation processes is achievable even for samples with high hematocrits.

15

Results from shear stress analysis on red cell samples subjected to flow indicate that flow path dimensions may be significantly reduced and high flow rates maintained without risking red cell hemolysis.

5 Example 8

A platelet concentrate was mixed with the platelet additive solution Isolyte S at a ratio of 20:80 platelet concentrate:Isolyte S. Mixtures of platelet concentrates and platelet additive solutions are referred to herein as in "media." Platelet concentrate without additive solution is referred to herein as in "plasma." Both were spiked with *Listeria monocytogenes*. Vitamin K5 was then added to each in the amount of 300 µg/mL. Each was then exposed to UV, visible or room light in the cuvette apparatus of Figure 7 with the results shown in Table 6.

Table 6

	Log Inactivation (cfu/mL)	
	K5 in Media	K5 in Plasma
UV, 40 J/cm <sup>2</sup>	4.2 Logs	0.1 Logs
VIS, 40 J/cm <sup>2</sup>	4.2 Logs	0.1 Logs
Room Light	0 Logs	0 Logs

15 UV Light = 365 nm  
 VIS Light = 419 nm  
 Pathogen = *Listeria monocytogenes*  
 Concentration of K5 = 300 µg/mL

20 Example 9

Media and plasma as described above containing vitamin K5 were spiked with bacteria and irradiated or exposed to room light only (K5-light) as shown in Table 7, and growth evaluated after three days of incubation. Inactivation of some species was seen in the absence of irradiation.

Table 7

	Spike Level (cfu/mL)	Media		Plasma	
		K5 + Light	K5 - Light	K5 + Light	K5 - Light
<i>P. aeruginosa</i>	3.4 Logs	-	-	-	-
<i>S. aureus</i>	2.1 Logs	-	-	+	+
<i>S. epidermidis</i>	3.2 Logs	-	+	-	-
<i>L. monocytogenes</i>	3.5 Logs	-	-	+	+
<i>E. coli</i>	3.1 Logs	-	-	+	-

UV Light = 365 nm, 40 J/cm<sup>2</sup>

+ = Growth detected after three days incubation

- = No Growth detected after three days incubation

Concentration of K5 = 300 µg/mL

#### Example 10

Media made using a platelet concentrate as described in Example 8 and Isolyte S at a ratio of Isolyte S:platelet concentrate of 70:30 and containing 300 µg/mL vitamin K5 was spiked with several species of bacteria and irradiated at energy levels of 30 and 60 J/cm<sup>2</sup>. Inactivation as a function of energy of irradiation is set forth in Table 8 and Figure 8.

Table 8

Energy (J/cm <sup>2</sup> )	<i>S. aureus</i>	<i>S. epidermidis</i>	<i>L. monocytogenes</i>	<i>E. coli</i>
0	4.3	2.6	2.8	3.5
30	3.6	2.7	2	2
60	3.2	2.5	1	1

#### Example 11

To platelet concentrate as described in Example 8 and to 70:30 media as described in Example 10 was added 10 µM of 7,8-dimethyl-10-ribityl isoalloxazine. The platelet concentrate and media were spiked with *S. aureus* or *S. epidermidis*, and irradiated at 80 J/cm<sup>2</sup> and 30 J/cm<sup>2</sup> and inactivation measured as above. Results are shown in Figure 9.

#### Example 12

To plasma concentrate as described in Example 8 contained in a standard blood bag was added 25 µM 7,8-dimethyl-10-ribityl isoalloxazine in powder form. The bag was spiked



with bacteria as shown in Table 9, agitated and exposed to 120 J/cm<sup>2</sup> radiation. Inactivation results are set forth in Table 9.

Table 9

Pathogen	Log Inactivation (cfu/mL)
<i>S. aureus</i>	1.7 Logs
<i>S. epidermidis</i>	3.5 Logs
<i>P. aeruginosa</i>	3.6 Logs
<i>E. coli</i>	4.1 Logs

5

Example 13

To platelet concentrate as described in Example 8 was added 7,8-dimethyl-10-ribityl isoalloxazine, alloxazine mononucleotide, or 7-8-dimethyl alloxazine, followed by spiking with *S. aureus* or *S. epidermidis*, and irradiation at 80 J/cm<sup>2</sup>. Inactivation results are shown in Table 10.

10

Table 10

	Log Inactivation (cfu/mL)	
	<i>Staphylococcus aureus</i>	<i>Staphylococcus epidermidis</i>
7,8-dimethyl-10-ribityl isoalloxazine, 10 $\mu$ M	1.9 Logs	4.1 Logs
alloxazine mononucleotide, 10 $\mu$ M	1.6 Logs	5.6 Logs
7-8-dimethyl alloxazine, 7 $\mu$ M	1.6 Logs	2.9 Logs

Example 14

To platelet concentrate of Example 8 was added 10  $\mu$ M 7,8-dimethyl-10-ribityl-isoalloxazine. Aliquots contained no additive, 10 micromolar ascorbate or 10 micromolar KI as a "quencher" or antioxidant. The solutions were spiked with HSV-2,  $\Phi$ X174, *S. epidermidis* or *S. aureus* and irradiated at 80 J/cm<sup>2</sup>. Results are shown in Figure 10.

15

Example 15

To platelet concentrates of Example 8 were added varying concentrations of 7,8-dimethyl-10-ribityl-isoalloxazine. These solutions were spiked with herpes simplex virus type II (HSV-II), a double-stranded DNA envelope virus. Irradiation was done at 80 J/cm<sup>2</sup>. The experiment was replicated three times. In all three trials complete inactivation was achieved. Results are shown in Figure 11.

20  
25

Example 16

The protocol of Example 15 was followed using *S. epidermidis* instead of HSV II at energies of irradiation of 40, 80 and 120 J/cm<sup>2</sup>. Inactivation results are shown in Figure 12.

5 Example 17

The protocol of Example 15 was followed using  $\Phi$ X174, a single stranded DNA bacteriophage, at varying concentrations of 7,8-dimethyl-10-ribityl-isoalloxazine and energies of irradiation. Inactivation results are shown in Figure 13.

10 Example 18

To platelet concentrates of Example 8 was added 10  $\mu$ M 7,8-dimethyl-10-ribityl-isoalloxazine. These were spiked with *S. aureus* or  $\Phi$ X174 and irradiated at varying energies of irradiation with a 50:50 mixture of visible and ultraviolet light. Inactivation results are shown in Figure 14.

15

Example 19

The protocol of Example 18 was followed using *S. epidermidis* and HSV-II as the microorganisms. A 50:50 mixture of ultraviolet and visible light was supplied by DYMAX light source. Inactivation results are shown in Figure 15.

20

Example 20

To platelet concentrate of Example 8 was added 10  $\mu$ M 7,8-dimethyl-10-ribityl-isoalloxazine in powdered form. Tests with and without added ascorbate were conducted. 150 ml of the test solutions were placed in a Spectra<sup>TM</sup> blood bag and shaken and exposed to varying energies of irradiation using 50:50 visible:ultraviolet light. After receiving 40 J/cm<sup>2</sup>, the contents of each bag were transferred to a new bag to avoid errors due to microorganisms which may have remained in the spike port of the bag. Inactivation results are shown in Figure 16. Downward arrows indicate inactivation to the level it was possible to detect (2.5 log titre).

25  
30Example 21

To platelet concentrate of Example 8 and platelet concentrate in Isolyte S at 30:70 platelet concentrate:Isolyte S, was added 20  $\mu$ M 7,8-dimethyl-10-ribityl-isoalloxazine. These were spiked with vaccinia virus, a double stranded DNA envelope virus, and exposed to 60 J/cm<sup>2</sup> visible light or mixed (50:50) visible and ultraviolet light using a DYMAX 2000 UV (Torrington, CT) light source for 30 minutes. The limit of detection was 1.5 logs. Inactivation results are show in Figure 17. Comparisons were done using no photosensitizer,

35

photosensitizer in Isolyte S media alone, platelets in Isolyte S media, platelets in Isolyte S media using 8-methoxy psoralen instead of 7,8-dimethyl-10-ribityl-isoalloxazine, and platelet concentrate in Isolyte media (30:70).

5 Example 22

Samples of platelet concentrate in Isolyte S media 30:70, with and without 10  $\mu\text{M}$  7,8-dimethyl-10-ribityl-isoalloxazine were spiked with vaccinia virus and irradiated at 60  $\text{J}/\text{cm}^2$  with 50:50 visible:UV light for varying periods of time and inactivation results compared as shown in Figure 18.

10

Example 23

To samples of platelet concentrate as described in Example 8 were added 5  $\mu\text{M}$  or 50  $\mu\text{M}$  7,8-dimethyl-10-ribityl-isoalloxazine. Samples were spiked with HIV 1. Using the cuvette flow cell shown in Figure 7, samples were irradiated with 50:50 visible:UV light at varying energies using an EFOS light system. Inactivation results are show in Figure 19.

15

Example 24

HIV-infected ACH-2 cells were added to samples of platelet concentrate described in Example 8. 5 or 50  $\mu\text{M}$  of 7,8-dimethyl-10-ribityl-isoalloxazine were added to the samples. The protocol of Example 23 was followed, and inactivation results are shown in Figure 20. The presence of HIV was assayed by its cytopathic effect on test cells.

20

Example 25

The protocol of Example 24 was followed and the presence of HIV assayed by quantifying the level of P24 antigen production. Inactivation results are show in Figure 21.

25

Example 26

To samples of platelet concentrate as described in Example 8 and media containing 30% platelet concentrate and 70% PASIII<sup>TM</sup> (Fenwal Labs., Deerfield, IL) media were added 6 micromolar ascorbate and 14  $\mu\text{M}$  7,8-dimethyl-10-ribityl-isoalloxazine. Samples were spiked with HSV-II. Inactivation results are show in Figure 22 and Table 11.

30

Table 11

Time (Minutes)	Energy (UV+VIS) J/cm <sup>2</sup>	30:70 PC:Media log virus titre	Energy (UV+VIS) J/cm <sup>2</sup>	90:10 PC:Media log virus titre
0	0	5.6	0	5.6
1.5	5	2.5	40	3.3
3	10	2.5	80	1.5 No Detectable Virus
4.5	15	2.3	120	1.5 No Detectable Virus
6	20	1.8		
9	30	1.6		
12	40			
24	80			
36	120			

Example 27 Inactivation of Phi-6 at varying hematocrit levels of red blood cells

Sample preparation:

5 Red blood cells were spun out from whole blood to >90% hematocrit, the plasma was removed, and the cells were diluted with 0.9% saline.

10 Samples of varying hematocrit levels were placed in a Charter Med PVC bag that contained riboflavin sufficient to provide a final concentration of 100 micromolar, spiked with Phi-6 (6 logs/mL or greater) and irradiated with 447 nm lights (Bililights) to provide an applied energy dose of 102 J/cm<sup>2</sup>. The inactivation of Phi-6 as a function of hematocrit is shown in Figure 24. It is seen that the hematocrit level has a significant effect on the amount of inactivation. Hematocrit levels of less than 40% provide the most inactivation of Phi-6.

15 Example 28 Inactivation as a function of plasma content for red blood cells

The inactivation of Phi-6 and Phi-X174 as a function of plasma content was determined as in Example 27 for red cells suspended in AS-3. 447 nm light was used (Bililights). Results are shown in Figures 25 (100 micromolar riboflavin, Phi-6) and 26 (50 micromolar riboflavin, Phi-X174). For both microorganisms, the level of inactivation  
20 decreased as the plasma content of the red blood cells increased. Also, a higher concentration of riboflavin increased the level of inactivation seen for all levels of plasma.

Example 29 Effect of energy applied on the level of inactivation of Phi-6 and BVDV in red blood cells

The effect that the amount of energy applied to the sample had on the level of inactivation was studied. Samples were prepared as above. Samples were full red cell units prepared at 35-40% hematocrit in AS-3 in a 2L Charter Med Bag, using 100 micromolar riboflavin. Results of the inactivation of Phi-6 are shown in Figure 27 using 447 (Bililights) and 470 nm (Custom Sea Life) light. Inactivation of BVDV was also studied with 447 nm light. The results for BVDV inactivation are shown in Figure 31.

Example 30 Effect of energy applied at varying hematocrit levels for inactivation of Phi-6

The effect of the energy level applied at different levels of hematocrit (10%, 40% and 60%) for inactivation of Phi-6 was studied. Samples were washed three times in saline with 50 micromolar riboflavin. All samples were 20 ml and were treated in 75cm<sup>2</sup> tissue culture flasks. Irradiation was performed from one side with sample mixing with 447 nm bilirubin lights at a flux of 7 mW/cm<sup>2</sup>. Results are shown in Figure 28. The results indicate that a lower hematocrit gives a faster inactivation at a lower energy level than a higher hematocrit.

Example 31 Kinetics of inactivation of Phi-6 in red blood cells

The kinetics of Phi-6 inactivation were studied using 470 nm and 447 nm light. 35% or 37% hematocrit samples in AS-3 with 400 ml volume were placed in a 1L CharterMed bag. Results are shown in Figures 29 (470 nm, 35% hematocrit) and 30 (447 nm, 37% hematocrit). Figures 29 and 30 also report the percent hemolysis of the samples as a function of time of exposure.

Example 32 Sample preparation for inactivation of microorganisms in Platelets

Samples of 30 ml platelet volume in B6 sample bags (bags with a 53ml total volume) were treated with 10 or 20 micromolar riboflavin and 419 nm light and then stored for 7 days. The samples were collected as hyperconcentrates on the SPECTRA™ apparatus and diluted with buffer to a final concentration of 20% of the initial plasma volume.

The buffer was used at a concentration of 20% buffer in 80% RODI water (Reverse Osmosis Deionized water) (pH 7.4) and contained the following:

- 78.3 mM sodium chloride
- 5.7 mM potassium chloride
- 1.7 mM magnesium chloride
- 34.3 mM sodium acetate
- 24.6 mM sodium phosphate (dibasic)
- 5.4 mM sodium phosphate (monobasic)

The plasma concentration may be reduced even further by the use of an appropriate storage solution, such as SETO-sol or other solutions known to those in the art, or developable by those of ordinary skill in the art without undue experimentation. These solutions contain glucose, which may be necessary to provide energy for cellular processes at low plasma concentrations. A lowered protein content would improve the kinetics and cell quality further.

Light was applied with 420 nm actinic light (output from around 400 nm to around 450 nm, peak at 420 nm, shown in Figure 36) for 15 minutes to apply 40 J/cm<sup>2</sup> and 30 minutes to apply 80 J/cm<sup>2</sup>.

#### Example 33 Cell quality data for platelets after treatment

The procedures described above were used to test the quality of the cells after the treatment with riboflavin and light when the cells were stored for seven days.

Table A shows the HSR (Hypotonic Shock Response) v. Storage time for a control solution (no riboflavin and no exposure to light) and the following samples:

- Sample A: control
- Sample B: 10 micromolar riboflavin, 40 J/cm<sup>2</sup> light
- Sample C: 20 micromolar riboflavin, 40 J/cm<sup>2</sup> light
- Sample D: 10 micromolar riboflavin, 80 J/cm<sup>2</sup> light
- Sample E: 20 micromolar riboflavin, 80 J/cm<sup>2</sup> light

Hypotonic shock response is a standard measurement which determines the effect of the treatment on platelet membrane integrity.

Three separate samples were measured for the average values shown in Table 12.

Table 12. Hypotonic Shock Response

Group	Day			
	1	3	5	7
A avg.	87.48%	85.91%	81.53%	70.65%
A st. dev.	0.03%	6.23%	5.85%	3.77%
B avg.	84.29%	80.74%	77.29%	63.29%
B st. dev.	9.95%	1.23%	2.98%	12.14%
C avg.	81.80%	83.45%	66.75%	52.38%
C st. dev.	8.27%	4.18%	18.02%	19.06%
D avg.	83.11%	80.55%	72.90%	47.92%
D st. dev.	7.13%	3.35%	7.71%	18.78%
E avg.	77.79%	68.77%	51.34%	28.06%
E st. dev.	5.04%	12.01%	23.06%	21.97%

5 Table 12 shows that the average hypotonic shock response decreases over seven days storage time for all solutions. The HSR of samples with a higher concentration of riboflavin added (samples B and D) decreased more over seven days than the solutions with a lower concentration of riboflavin added (samples A and C).

Example 34 Change in pH of platelet solution during storage

10 Table 13 shows the change in pH of the samples described above, after storage for seven days.

Table 13. pH Results

Day					Group
0	1	3	5	7	
7.26	7.22	7.24	7.28	7.27	A avg.
0.10	0.10	0.10	0.09	0.11	A st. dev.
7.23	7.17	7.16	7.14	7.15	B avg.
0.12	0.12	0.11	0.11	0.17	B st. dev.
7.19	7.11	7.04	6.98	7.09	C avg.
0.10	0.12	0.15	0.19	0.21	C st. dev.
7.21	7.16	7.15	7.04	7.16	D avg.
0.11	0.11	0.12	0.19	0.17	D st. dev.
7.18	7.12	7.07	7.00	7.10	E avg.
0.11	0.12	0.14	0.18	0.19	E st. dev.

Example 35 pCO<sub>2</sub> v. storage time for platelets

5 Table 14 shows the pCO<sub>2</sub> results for the samples described above.

Table 14. pCO<sub>2</sub> (mm Hg)

Day					Group
0	1	3	5	7	
8.33	10.33	10.00	8.67	8.00	A avg.
0.58	2.08	2.00	2.08	1.00	A st. DEv.
8.33	11.00	10.67	10.00	7.33	B avg.
2.08	2.65	2.52	2.65	2.08	B st. Dev.
10.00	12.33	11.67	9.00	6.00	C. avg.
1.00	1.15	1.53	1.73	1.00	C st. dev.
9.33	11.67	11.67	13.67	9.67	D avg.
1.15	2.31	2.52	6.66	5.51	D st. dev.
9.67	12.00	11.67	9.00	10.00	E. avg.
1.53	1.73	2.52	2.00	8.66	E st. dev.

Example 36 pO<sub>2</sub> and cell count for platelet storage



Table 15 shows the pO<sub>2</sub> results and cell counts as a function of time for the samples described above. The oxygen consumption was measured using standard tests.

Table 15. pO<sub>2</sub> Results (mm Hg) and Cell Count Results

pO <sub>2</sub> (mmHg)		Cell Count								
		Day								
0		1	3	5	7	1	3	5	7	
77.33		73.67	81.33	98.67	101.33	A av.	1203.00	1214.33	1198.00	1184.67
34.27		25.50	13.80	10.97	5.86		A st. dev.	245.71	329.18	234.71
49.33		72.67	78.67	85.67	104.33	B av.	1060.67	1130.33	1128.33	1098.00
8.50		24.54	18.50	23.46	10.21		B st. dev.	309.81	318.53	333.38
57.67		68.33	75.00	92.00	113.67	C av.	1204.67	1231.67	1245.00	1109.00
13.58		17.79	11.53	9.54	7.23		C st. dev.	208.08	223.68	192.54
53.00		64.00	72.00	69.67	81.00	D av.	1126.67	1150.33	1194.67	1091.00
8.72		19.67	17.35	41.02	56.31		D st. dev.	218.21	279.88	244.76
43.67		65.33	73.33	89.00	96.67	E av.	1111.33	1128.00	1057.67	942.33
7.51		22.03	16.20	20.81	62.95		E st. dev.	254.23	215.09	168.17

Example 37 GMP-140 activation in platelets with reduced plasma

Table 16 shows GMP 140 activation as a function of time for the samples described above. GMP-140 is a measure of platelet activation, and is measured by flow cytometry.

5

Table 16. GMP-140 Activation

Day				Group
1	3	5	7	
0.18	0.28	0.29	0.40	A avg.
0.07	0.13	0.09	0.06	A st. dev.
0.34	0.39	0.45	0.57	B avg.
0.16	0.14	0.11	0.06	B st. dev.
0.36	0.43	0.53	0.64	C avg.
0.07	0.06	0.07	0.01	C st. dev.
0.33	0.43	0.51	0.66	D avg.
0.12	0.10	0.06	0.03	D st. dev.
0.43	0.54	0.65	0.77	E avg.
0.11	0.06	0.04	0.07	E st. dev.

Example 38 Swirl Results

The platelet swirl was also tested. Table 17 shows the change in swirl results for the samples described above. In Table 17, the swirl scale where a value of 3 indicates a ++ platelet swirl, a value of 2 indicates a + platelet swirl, a value of 1 indicates a +/- platelet swirl, and a value of 0 indicates a - platelet swirl is used.

10

Table 17 indicates that a 10 micromolar riboflavin and 20 J/cm<sup>2</sup> treatment does not affect that platelet swirl over seven days, whereas a treatment with 20 micromolar riboflavin and 40 J/cm<sup>2</sup> decreases the platelet swirl to 2 over seven days. None of the samples experienced a decrease in platelet swirl score after three days.

15

Table 17. Swirl Results

Day					Group
0	1	3	5	7	
3.00	3.00	3.00	3.00	3.00	A avg.
0.00	0.00	0.00	0.00	0.00	A st. dev.
3.00	3.00	3.00	3.00	3.00	B avg.
0.00	0.00	0.00	0.00	0.00	B st. dev.
3.00	3.00	3.00	2.67	2.67	C avg.
0.00	0.00	0.00	0.58	0.58	C st. dev.
3.00	3.00	3.00	3.00	2.33	D avg.
0.00	0.00	0.00	0.00	1.15	D st. dev.
3.00	3.00	3.00	2.67	2.00	E avg.
0.00	0.00	0.00	0.58	0.00	E st. dev.

Example 39 Lactate results as a function of time for platelet sample with reduced plasma

5 Table 18 shows the lactate concentration as a function of time for the samples described above. Generation of lactate is a measure of anaerobic metabolism. All samples, including the control sample, experienced an increase in the lactate concentration over seven days storage.

Table 18. Lactate (mmol/L)

Group	Day			
	1	3	5	7
A av.	2.00	3.41	5.30	7.86
A st. dev.	0.26	0.39	0.93	1.39
B avg.	2.55	4.50	7.19	9.48
B st. dev.	0.54	1.03	1.55	3.03
C avg.	3.80	7.28	10.90	11.22
C st. dev.	0.53	1.75	2.60	2.56
D avg.	2.58	4.54	8.78	10.09
D st. dev.	0.42	0.92	2.58	2.82
E avg.	3.21	5.93	9.46	9.02
E st. dev.	0.55	1.31	2.38	3.51

Example 40 Morphology of platelets

Table 19 shows the change in morphology score as a function of time for the samples described above.

5

Table 19. Morphology Score

Day				
1	3	5	7	Group
259.00	230.00	223.33	224.67	A avg.
3.46	10.58	2.31	11.93	A st. dev.
242.67	215.67	224.67	210.00	B avg.
26.54	26.31	6.51	19.47	B st. dev.
233.33	219.67	218.67	211.67	C avg.
11.02	12.06	20.98	29.84	C st. dev.
231.67	216.33	224.00	218.33	D avg.
20.55	30.27	3.00	11.93	D st. dev.
230.67	220.67	220.33	203.67	E avg.
5.13	12.34	20.65	10.97	E st. dev.

Example 41 Inactivation of BVDV virus in platelets with reduced plasma

To the samples described above, BVDV virus was added before addition of riboflavin and before exposure to 419 nm light. The starting titre of the BVDV was 4.3 or 3.9 (zero values). The inactivation of the virus was studied as a function of riboflavin concentration added and light applied. The BVDV virus is used as a model for Hepatitis C. At 40 J/cm<sup>2</sup>, complete kill is seen (the sensitivity of the test is 1.3 logs).

10

The average results for three separate samples at each treatment combination are shown below.

15

Table 20. BVDV Inactivation as a function of energy for 10 and 20 micromolar riboflavin

Energy (J/cm <sup>2</sup> )	10 micromolar riboflavin		20 micromolar riboflavin	
	Avg.	Std. Dev.	Avg.	Std. Dev.
0	4.3	0.1	3.9	0.5
40	≤ 1.4	0.2	≤ 1.4	0.2
80	≤ 1.3	0.0	≤ 1.3	0.0

Example 42 Plasma Preparation

For studies of plasma proteins, either stericon bags, CharterMed bags, or tissue culture flasks were used. Light was delivered with a Dymax Source (365, 419, 447 nm). Plasma protein factor activity levels were determined by standard protein activity assays.

Example 43 The effect of air on microorganism inactivation in plasma

The amount of the inactivation of the microorganism *S. epidermidis* using 10 micromolar riboflavin is not dependent on the presence of air in a sample of 18 ml plasma and 2 ml riboflavin solution (unreported results), but air has a significant effect on the amount of protein damage that occurs upon irradiation. Figures 32 and 33 compare the protein factor activity recovery levels as a function of energy level of a sample treated in a stericon bag with 10 mm riboflavin. When ascorbate is added, the effect of air degradation is decreased (see Figure 34).

Shown in Table 21 is the percentage recovery of various proteins treated with 3 micromolar methylene blue with 43 J/cm<sup>2</sup> light applied with a sodium arc lamp. The data is from Transfusion (1998) 38: Abstract S239.

Table 21. Methylene Blue

Protein	% Recovery
Factor II	93
Factor V	88
Factor VII	98
Factor VIII	76
Factor IX	84
Factor X	93
Factor XI	69
Factor XII	-
Protein C	96
Protein S	117
Fibrinogen	71

Example 44 Plasma Protein Studies

Table 22 summarizes various plasma protein treatments using ascorbate in the buffer. These experiments were performed in tissue culture flasks that contain air.

5

Sample A was a 90% plasma/10% media formulation in CAS II-2. 80 J/cm<sup>2</sup> of light (40 J/cm<sup>2</sup> UVA) was applied to sample A with a DYMAX 2000 irradiator. Sample B was a 90% plasma/10% media formulation in CAS II-2. 105 J/cm<sup>2</sup> of light (53 J/cm<sup>2</sup> UVA) was applied to sample B with a DYMAX 2000 irradiator.

10

The CAS II-2 buffer formulation used had 139 mM sodium phosphate dibasic, 43 mM sodium phosphate monobasic, 100 micromolar riboflavin and 100 mM sodium ascorbate. These values were reduced by a factor of 10 after mixing with the plasma. The pH of the buffer before mixing with plasma was 7.4. The pH of the solution after mixing the buffer and plasma was 7.2.

15

Samples C and D were a 90% plasma/10% media formulation. The media was 100 micromolar riboflavin in 0.9% saline with final concentration of ascorbate of 10 micromolar. The pH of the media was initially 5.0, and the pH after mixing with plasma was 7.0. After mixing the media and plasma, the riboflavin concentration was 10 micromolar. 103 J/cm<sup>2</sup> of light was applied (30 J/cm<sup>2</sup> UVA was applied) with a UVP irradiator (365 nm and 419 nm).

20

Table 22: Plasma Protein Studies

Protein	A	B	C	D	Average	STD DEV	Normal Adult Ranges
	% Activity Pre-Treatment	% Activity Pre-Treatment	% Activity Pre-Treatment	% Activity Pre-Treatment			
Factor II	86	88	67	73	78.3	9.9	75.0 - 135.0
Factor V	56	80	69	66	67.8	9.9	70.0 - 150.0
Factor VII	81	49	57	73	65.0	14.6	50.0 - 155.0
Factor VIII	96	123	77	35	82.8	37.0	50.0 - 155.0
Factor IX	78	80	77	67	75.5	5.8	60 - 150.0
Factor X	83	71	71	67	73.0	6.9	65.0 - 135.0
Factor XI	83	78	85	58	76.0	12.4	60.0 - 150.0
Factor XII	81	38	50	41	52.5	19.7	50.0 - 150.0
APTT			32.4	40.6	36.5	5.8	24.0 - 36.0
Fibrinogen			227	212	219.5	10-6	160.0 - 350.0
Euglobulin Lysis Time			5.0	6.5	5.8	1.1	2.0 - 10.0
Plasminogen			86	71	78.5	10.6	65.0 - 150.0
Antithrombin			59	62	60.5	2.1	70.0 - 130.0
Protein C. Antigen			77	79	78.0	1.4	60.0 - 150.0
Protein C Activity			58	68	63.0	7.1	55.0 - 140.0
Protein S. Antigen			81	83	82.0	1.4	60.0 - 150.0
Protein S. Activity (Clot)			82	85	83.5	2.1	50.0 - 140.0
APC Resistance +FV Def.			2.8	2.9	2.9	0.1	2.20 - 4.00

TABLE 22 (Continued)

Protein	% Activity Post-Treatment	% Activity Post-Treatment	% Activity Post-Treatment	% Activity Post-Treatment	% Activity Post-Treatment	Average	STD DEV	% Recovery
Factor II	71	76	58	60	66.2	8.7	84.6	
Factor V	49	61	49	49	52.0	6.0	76.7	
Factor VII	75	45	49	61	57.5	13.5	88.4	
Factor VIII	80	117	67	30	73.4	35.9	88.7	
Factor IX	64	70	62	63	64.8	3.5	85.8	
Factor X	78	64	60	56	64.5	9.6	88.4	
Factor XI	84	70	81	58	73.3	11.8	96.4	
Factor XII	76	34	49	43	50.5	18.1	96.1	
			39	43	40.8	2.5		
			191	185	188.1	4.3	85.7	
			5.8	5.8	5.8	0.0	100.0	
			81	68	74.6	9.3	95.0	
			56	65	60.3	6.7	99.6	
			78	65	71.4	9.0	91.5	
			53	63	58.2	6.8	92.3	
			72	74	73.1	1.3	89.2	
			90.0	96.0	93.0	4.2	111.4	
			2.9	2.7	2.8	0.1	98.1	



When ascorbate was not added to samples C and D, the percent recovery decreased (data not shown). This effect was particularly pronounced for Factors V, VIII, IX, X and Fibrinogen.

5 Table 23 shows plasma protein recovery in samples (in charter Med IL bags) with and without air and with and without ascorbate (ASC). The table shows that a significant amount of protein damage occurs when air is present in the samples. If air is present, the addition of ascorbate assists in minimizing the extent of protein damage.

10 Table 23. Plasma Studies

	FV	FVIII	FIX	FX	FIB	Energy
No Air	96.7	77.5	85.1	91.7	109.3	132
No Air	96.7	73.9	90.4	88.1	105.5	264
No Air	76.0	63.8	84.0	85.3	105.9	396
No Air	85.2	68.3	81.3	88.4	87.3	264
No Air	76.7	62.9	78.4	80.0	83.3	528
No Air	87.3	75.4	80.0	77.3	90.2	528
+Air	13.0	16.1	33.3	30.7	1.7	264
+Air	26.9	24.8	40.4	45.5	2.5	132
+Air	9.3	12.4	28.3	27.7	2.1	396
Flask	11.2	13.6	32.0	30.6	2.2	132
+Air+1 mM ASC	51.5	14.4	64.6	64.4	33.4	132
	24.5	13.5	40.2	43.7	1.3	264
	18.4	13.5	34.1	38.8	1.6	396
+Air+10 mM ASC	64.4	88.2	84.9	85.5	89.6	264
	22.2	76.9	77.0	80.7	70.2	528
	65.0	80.4	76.6	79.5	90.2	528

Example 45 Effect of Container size on inactivation of Phi-6 in plasma

15 The effect of Phi-6 inactivation in different sized containers was also studied. 250 ml plasma with 10 micromolar riboflavin was added to either a 2L CharterMed, a 2L Stericon bag or a 1L stericon bag. The pathogen in the 1L bags was not inactivated to as great an extent as the pathogen in the 2L bags.

Example 46 Inactivation of porcine parvo in plasma

Porcine parvo is similar to a human virus (parvovirus B19) that is hard to detect and remove or inactivate in blood components. Also, parvo is very hard to inactivate using existing methods of microorganism inactivation. To test the effect of removing part of the plasma on the ability of riboflavin to inactivate parvo, samples of plasma containing  $\geq 6$  logs/mL (concentration) of parvo virus were diluted in saline to a final concentration of 20% or less plasma. 10 or 50 micromolar riboflavin was added, and the samples irradiated with 365 + 419 + 447 nm (Dymax Source) light for 30 or 60 minutes. Under these conditions, 6 logs of kill were seen.

Table 24

% Plasma Content	30 Minutes		60 Minutes	
	10 Micromolar	50 Micromolar	10 Micromolar	50 Micromolar
0	6.4	6.5	6.5	6.5
5	6.5	6.5	6.0	5.8
10	6.5	6.5	5.4	4.7
15	2.7	6.5	4.4	3.0
20	2.0	4.5	3.3	2.2

It should be understood that the light source described as “470 nm” used in these experiments has a broad spectral output from around 400 - 520 nm. The spectral output is shown in Figure 35. This light was from Custom Sea Life, and was a 7100 K Blue 28 watt Twin Tube. “419 nm” light was provided by Super Actinic Lights with spectral output shown in Figure 36. “447 nm” light was typically provided from a bililight source. Other sources of radiation may be used, as long as they provide suitable wavelengths and intensities.

It will be readily understood by those skilled in the art that the foregoing description has been for purposes of illustration only and that a number of changes may be made without departing from the scope of the invention. For example, other photosensitizers than those mentioned may be used, preferably photosensitizers which bind to nucleic acid and thereby keep it from replicating, and more preferably those which are not toxic and do not have toxic degradation products. In addition, equivalent structures to those described herein for constructing a flow-through system for decontamination of fluids using photosensitizers may be readily devised without undue experimentation by those skilled in the art following the teachings hereof. In addition, the level of plasma removal in blood or a blood component to achieve the desired level of inactivation of a particular microorganism or microorganisms

may be readily determined using the methods described herein, or methods known to those of ordinary skill in the art without undue experimentation.

5 All references cited herein are incorporated by reference to the extent not inconsistent with the disclosure herein.

## CLAIMS

We claim:

1. A method for treating a fluid to inactivate microorganisms which may be present therein, said fluid containing one or more components selected from the group consisting of protein, blood and blood constituents, said method comprising:
  - (a) adjusting the percentage of plasma in said fluid to a desired value;
  - (b) mixing an inactivation-effective, substantially non-toxic amount of an endogenous photosensitizer or endogenously-based derivative photosensitizer with said fluid;
  - (c) exposing said fluid to photoradiation of sufficient wavelength and energy to activate the photosensitizer, whereby said microorganisms are inactivated.
2. The method of claim 1, wherein said adding step occurs after said adjusting step.
3. The method of claim 1, wherein said adjusting step occurs after said adding step.
4. The method of claim 1, wherein said adjusting step and said adding step occur simultaneously.
5. The method of claim 1, wherein said adjusting step comprises adding a sufficient volume of a diluting solution to the fluid so that the percentage of plasma is at a desired value.
6. The method of claim 5, wherein said diluting solution is saline.
7. The method of claim 5, wherein said diluting solution is a buffer.
8. The method of claim 5, wherein said diluting solution includes nutrients.
9. The method of claim 8, wherein said diluting solution includes phosphate.
10. The method of claim 5, wherein said diluting solution is a cell storage solution.
11. The method of claim 5, wherein said diluting solution is an anticoagulant.
12. The method of claim 5, wherein said diluting solution is a cryopreservative solution.
13. The method of claim 1, wherein said adjusting step comprises washing the fluid.

14. The method of claim 13 including a plurality of washing steps.
- 5 15. The method of claim 1 wherein said photosensitizer is a photo-activatable compound whose photolytic products (if any) are of low or no toxicity to humans or animals.
16. The method of claim 15 wherein said photosensitizer is 7,8-dimethyl-10-ribityl isoalloxazine.
- 10 17. The method of claim 1 wherein said microorganisms are selected from the group consisting of bacteria, bacteriophages, and intracellular and extracellular viruses.
18. The method of claim 1 wherein said microorganisms are bacteria.
- 15 19. The method of claim 1 wherein said microorganisms are selected from the group consisting of HIV viruses, hepatitis viruses, sindbis virus, cytomegalovirus, vesicular stomatitis virus, herpes simplex viruses, vaccinia virus, human T-lymphotropic retroviruses, HTLV-III, lymphadenopathy virus LAV/IDAV, parvovirus, transfusion-transmitted (TT) virus, Epstein-Barr virus, bacteriophages  $\Phi$ X174,  $\Phi$ 6,  $\lambda$ , R17, T<sub>4</sub>, T<sub>2</sub>,  
20 *P. aeruginosa*, *S. aureus*, *S. epidermidis*, *L. monocytogenes*, *E. coli*, *K. pneumoniae* and *S. marcescens*.
20. The method of claim 1 wherein said photoradiation is light in the visible spectrum.
- 25 21. The method of claim 1, wherein said photoradiation is light in the ultraviolet spectrum.
22. The method of claim 1, wherein said photoradiation is light in both the visible and ultraviolet spectra.
- 30 23. The method of claim 22, wherein about half the light is in the visible spectrum and about half the light is in the ultraviolet spectrum.
24. The method of claim 22, wherein about one third of the light is in the visible spectrum  
35 and about two thirds of the light is in the ultraviolet spectrum.

25. The method of claim 22, wherein about two thirds of the light is in the visible spectrum and about one third of the light is in the ultraviolet spectrum.
- 5 26. The method of claim 1, wherein said photoradiation is of sufficient wavelength to activate 7,8-dimethyl-10-ribityl isoalloxazine in the fluid.
- 10 27. The method of claim 1, wherein the percentage of plasma in said fluid is adjusted to be within about 0 to about 50 percent of the total volume of said fluid when said fluid contains platelets, red blood cells, or a combination of both.
- 15 28. The method of claim 1, wherein the percentage of plasma in said fluid is adjusted to be within about 0 to about 20 percent of the total volume of said fluid when said fluid contains platelets, red blood cells, or a combination of both.
- 20 29. The method of claim 1, wherein the percentage of plasma in said fluid is adjusted to be within about 0 to about 10 percent of the total volume of said fluid when said fluid contains platelets, red blood cells, or a combination of both.
- 30 30. The method of claim 1, wherein the percentage of plasma in said fluid is adjusted to be within about 99 to about 80 percent of the total volume of said fluid.
31. The method of claim 1 wherein said photosensitizer is added to anticoagulant and said anticoagulant is added to said fluid.
- 25 32. A method of claim 1 wherein an enhancer is added to said fluid prior to exposing said fluid to photoradiation.
- 30 33. A method of claim 32 wherein said enhancer is selected from the group consisting of adenine, histidine, cysteine, tyrosine, tryptophan, ascorbate, N-acetyl-L-cysteine, propyl gallate, glutathione, mercaptopropionylglycine, dithiothreitol, nicotinamide, BHT, BHA, lysine, serine, methionine, glucose, mannitol, trolox, glycerol, and mixtures thereof.
- 35 34. The method of claim 1 wherein said exposing step comprises flowing the fluid containing said photosensitizer past a source of photoradiation at a rate and depth selected to ensure penetration of the photoradiation through the fluid and inactivation of the microorganisms.

35. The method of claim 1 wherein said fluid and photosensitizer are contained in a container transparent to said photoradiation.
- 5 36. The method of claim 35 further comprising agitating said container during said exposing step.
37. The method of claim 1 wherein said adding step further comprises placing said fluid in a container transparent to said photoradiation, adding said photosensitizer to said fluid in powder form, and agitating said container.
- 10 38. The method of claim 37, wherein said percentage of plasma is adjusted before placing said fluid in said container.
- 15 39. The method of claim 37, wherein said percentage of plasma is adjusted after placing said fluid in said container.
40. The method of claim 37, wherein said percentage of plasma is adjusted simultaneously with placing said fluid in said container.
- 20 41. The method of claim 37, further comprising adding nutrients in powder form to said container.
42. The method of claim 37 wherein said nutrients and photosensitizer are present in the container prior to addition of said fluid.
- 25 43. The method of claim 1 wherein said fluid comprises blood constituents.
44. The method of claim 1 wherein said fluid comprises whole blood.
- 30 45. The method of claim 1 wherein said fluid comprises a separated blood product.
46. The method of claim 1 wherein said fluid consists essentially of platelets.
- 35 47. The method of claim 1 wherein said fluid consists essentially of serum.
48. The method of claim 1 wherein said fluid consists essentially of plasma.

49. The method of claim 1 wherein said fluid consists essentially of red blood cells.
50. A method for treating a fluid containing platelets to inactivate microorganisms which  
5 may be present therein, said method comprising:  
(a) mixing an inactivation-effective, substantially non-toxic amount of an  
endogenous photosensitizer with a fluid which contains platelets and a plasma  
content of between about 0% to about 50% of the total volume of the fluid;  
(b) exposing said fluid to photoradiation of sufficient wavelength and energy to  
10 activate the photosensitizer, whereby said microorganisms are inactivated.
51. The method of claim 50, wherein said fluid contains between about 0 to about 25% of  
the total volume of said fluid.
- 15 52. The method of claim 50, wherein said fluid contains plasma at a volume of less than  
25% of the total volume of said fluid.
53. The method of claim 50, wherein said method further comprises:  
adding sufficient additives to the fluid so that one or more proteins present in said  
20 fluid remains biologically active after said exposing step.
54. The method of claim 50, wherein said photosensitizer is 7,8-dimethyl-10-ribityl  
isoalloxazine.
55. The method of claim 50, wherein said photosensitizer is present at a concentration of  
25 between about 1 to about 200 micromolar.
56. The method of claim 50, wherein said photoradiation is between about 400 and about  
500 nm.
- 30 57. The method of claim 50, wherein said photoradiation is between about 100 and about  
500 J/cm<sup>2</sup>.
58. The method of claim 50, wherein said photoradiation is between about 100 and about  
200 J/cm<sup>2</sup>.
- 35 59. A method for treating a fluid containing red blood cells to inactivate microorganisms  
which may be present therein, said method comprising:



- (a) adding an inactivation-effective, substantially non-toxic amount of an endogenous photosensitizer to a fluid which contains red blood cells and a plasma content of between about 0 % to about 50% of the total volume of said fluid;
- 5 (b) exposing said fluid to photoradiation of sufficient wavelength and energy to activate the photosensitizer, whereby said microorganisms are inactivated.
60. The method of claim 59, wherein said plasma content in said fluid is less than about 10% of the total volume of said fluid.
- 10 61. The method of claim 59, wherein said plasma content is less than about 5% of the total volume of said fluid.
62. The method of claim 59, wherein said photosensitizer is 7,8-dimethyl-10-ribityl isoalloxazine.
- 15 63. The method of claim 59, wherein said photosensitizer is present at a concentration of between about 1 to about 200 micromolar.
- 20 64. The method of claim 59, wherein said photosensitizer is present at a concentration of between about 50 to about 150 micromolar.
65. The method of claim 59, wherein said photoradiation is between about 420 and about 500 nm.
- 25 66. The method of claim 59, wherein said photoradiation is between about 100 and about 500 J/cm<sup>2</sup>.
67. The method of claim 59, wherein said photoradiation is between about 50 and about 200 J/cm<sup>2</sup>.
- 30 68. A method for treating a fluid containing plasma to inactivate microorganisms which may be present therein, said method comprising:
- (a) adding an inactivation-effective, substantially non-toxic amount of an endogenous photosensitizer to a fluid having a plasma content of between about 60 % to about 100% of the total volume of said fluid;
- 35

(b) exposing said fluid to photoradiation of sufficient wavelength and energy to activate the photosensitizer, whereby said microorganisms are inactivated.

- 5 69. The method of claim 68, wherein said fluid contains about 90% or less plasma by volume.
70. The method of claim 68, wherein said photosensitizer is 7,8-dimethyl-10-ribityl isoalloxazine.
- 10 71. The method of claim 68, wherein said photosensitizer is present at a concentration of between about 5 to about 15 micromolar.
72. The method of claim 68, wherein said photoradiation is between about 300 and about 500 nm.
- 15 73. The method of claim 68, wherein said photoradiation is between about 100 and about 500 J/cm<sup>2</sup>.
74. The method of claim 68, wherein said photoradiation is between about 300 and about 500 J/cm<sup>2</sup>.
- 20 75. The method of claim 1 wherein said fluid comprises a therapeutic protein composition.
- 25 76. The method of claim 1 wherein said fluid contains a biologically-active protein selected from the group consisting of: factor VIII, Von Willebrand factor, factor IX, factor X, factor XI, Hageman factor, prothrombin, anti-thrombin III, fibronectin, plasminogen, plasma protein fraction, peritoneal dialysis solutions, immune serum globulin, modified immune globulin, albumin, plasma growth hormone, somatomedin, plasminogen streptokinase complex, ceruloplasmin, transferrin, 30 haptoglobin, antitrypsin and prekallikrein.
77. The method of claim 1 wherein the activity of a biologically-active protein in said fluid is at a biologically-active level after said exposing step.
- 35 78. An apparatus for inactivating microorganisms which may be present in a fluid, said fluid having a portion of the plasma removed, with an endogenous or endogenously-based derivative photosensitizer, comprising:

- (a) a source of light that emits light of a suitable wavelength and intensity to activate the endogenous or endogenously-based derivative photosensitizer;
- (b) means for maintaining the fluid and an effective amount of an endogenous or endogenously-based derivative photosensitizer in the light path for a sufficient time to achieve the desired level of inactivation.

5

79. The apparatus of claim 78, wherein said means for maintaining the fluid and an effective amount of an endogenous or endogenously-based derivative photosensitizer in the light path comprises a support surface substantially parallel to said source of light.

10

80. The apparatus of claim 78, wherein said light source comprises one or more light emitting diodes.

15

81. The apparatus of claim 80, wherein said light emitting diodes emit light in the visible range of the spectrum.

82. The apparatus of claim 78, wherein said fluid comprises blood or blood components.

20

83. The apparatus of claim 78, wherein said photosensitizer is 7,8-dimethyl-10-ribityl isoalloxazine.

84. A system for treating a fluid to inactivate microorganisms which may be present therein with an endogenous or endogenously based photosensitizer comprising:

25

- (a) a container comprising said fluid having a reduced level of plasma, at least an effective amount of an endogenous photosensitizer or endogenously-based derivative photosensitizer, and optionally one or more additives, said container having a surface sufficiently photopermeable to allow exposure of the fluid therein to an amount of photoradiation sufficient to activate the photosensitizer;
- (b) at least one photoradiation source in light communication with said container, said source capable of generating a suitable wavelength and intensity to activate the endogenous photosensitizer or endogenously-based derivative photosensitizer whereby microorganisms present are inactivated.

30

35

85. The system of claim 84, wherein said photosensitizer is 7,8-dimethyl-10-ribityl isoalloxazine.

86. The system of claim 84 wherein said photoradiation source provides light in the visible spectrum.
- 5 87. The system of claim 84, wherein said photoradiation source provides light in the ultraviolet spectrum.
88. The system of claim 84, wherein said photoradiation source provides light in both the visible and ultraviolet spectrum.
- 10 89. The system of claim 84 also comprising a photoradiation enhancer.
90. The system of claim 89 wherein said photoradiation enhancer comprises a reflective surface.
- 15 91. The system of claim 84 comprising a light guide for conducting photoradiation from said photoradiation source to said photopermeable container.
92. The system of claim 84 also comprising a temperature monitor.
- 20 93. The system of claim 84 also comprising one or more temperature controllers.
94. The system of claim 93 wherein said temperature controller is a fan directed so as to cool the light source and/or the fluid.
- 25 95. The system of claim 84 also comprising means for flowing said fluid into and out of said container.
96. The system of claim 84 also comprising means for agitating said fluid.
- 30 97. A system for inactivation of microorganisms in a fluid containing such microorganisms comprising:
- (a) means for adjusting the plasma content of said fluid;
  - (b) means for mixing an effective amount of an endogenous photosensitizer or endogenously-based derivative photosensitizer with said fluid in fluid
- 35 communication with said means for adjusting the plasma content of said fluid;

- 5 (c) a photopermeable container for said fluid in fluid communication with said means for adding photosensitizer and said means for adjusting the plasma content having a depth and length selected to allow exposure of the fluid of step (b) therein to an amount of photoradiation sufficient to activate the photosensitizer at a selected flow rate;
- (d) means for producing said selected flow rate of said fluid through said container; and
- 10 (e) at least one photoradiation source in light communication with said container, said source capable of providing sufficient photoradiation to the fluid in said container of a type and amount selected to activate the photosensitizer.
98. A system for treating a fluid to inactivate microorganisms which may be present therein comprising:
- 15 (a) means for adjusting the percentage of plasma in said fluid;
- (b) means for adding an effective amount of endogenous or endogenously-based photosensitizer to said fluid;
- (c) a photopermeable container for said fluid of depth which allows exposure of the fluid to an amount of photoradiation sufficient to activate the photosensitizer;
- 20 (d) means for agitating said container;
- (e) at least one photoradiation source for providing sufficient photoradiation to the fluid in said container of a type and amount selected to activate the photosensitizer.
- 25 99. The system of claim 98 wherein said photopermeable container is a transparent plastic bag.
100. The system of claim 99 wherein said photopermeable container is a transparent rigid plastic container.
- 30 101. The system of claim 98 wherein said means for agitating said container comprises a shaker table.
102. The system of claim 98 wherein said photopermeable container contains said photosensitizer prior to addition of said fluid.
- 35

103. The system of claim 98 wherein said means for adjusting the level of plasma in said fluid comprises a suitable amount of a solution contained in said container.
104. A method for collecting a fluid with reduced levels of microorganisms that may be present therein, said fluid containing one or more members of the group consisting of: blood and blood components, comprising:
- (a) placing said fluid in a photopermeable container;
  - (b) adding an endogenous or endogenously-based derivative photoactive material to said container;
  - (c) adjusting the level of plasma in said fluid to a desired level;
  - (d) exposing said fluid to radiation of a sufficient wavelength and intensity to activate said photoactive material, whereby microorganisms are inactivated.
105. The method of claim 104 wherein said photoactive material is present in said container prior to placing said fluid therein.
106. An apparatus for collecting a fluid with reduced levels of microorganisms that may be present therein, said fluid containing one or more members of the group consisting of: blood and blood components, comprising:
- (a) a photopermeable container containing an endogenous or endogenously-based derivative photoactive material and a suitable volume of a solution for adjusting the level of plasma in the fluid to a desired level;
  - (b) a light source in light communication with said container that emits light of a suitable wavelength and intensity to inactivate microorganisms which may be present in said fluid.
107. A method for treating a fluid to inactivate microorganisms which may be present therein, said fluid containing one or more components selected from the group consisting of protein, blood and blood constituents, said method comprising:
- (a) removing a desired amount of the bilirubin present in the fluid;
  - (b) adding an inactivation-effective, substantially non-toxic amount of an endogenous photosensitizer or endogenously-based derivative photosensitizer to said fluid;
  - (c) exposing said fluid to photoradiation of sufficient wavelength and energy to activate the photosensitizer, whereby said microorganisms are inactivated.

108. A blood product comprising inactivated microorganisms and endogenous photosensitizer or endogenously-based derivative photosensitizer and a lowered plasma content than occurs naturally, made by the method of claim 1.

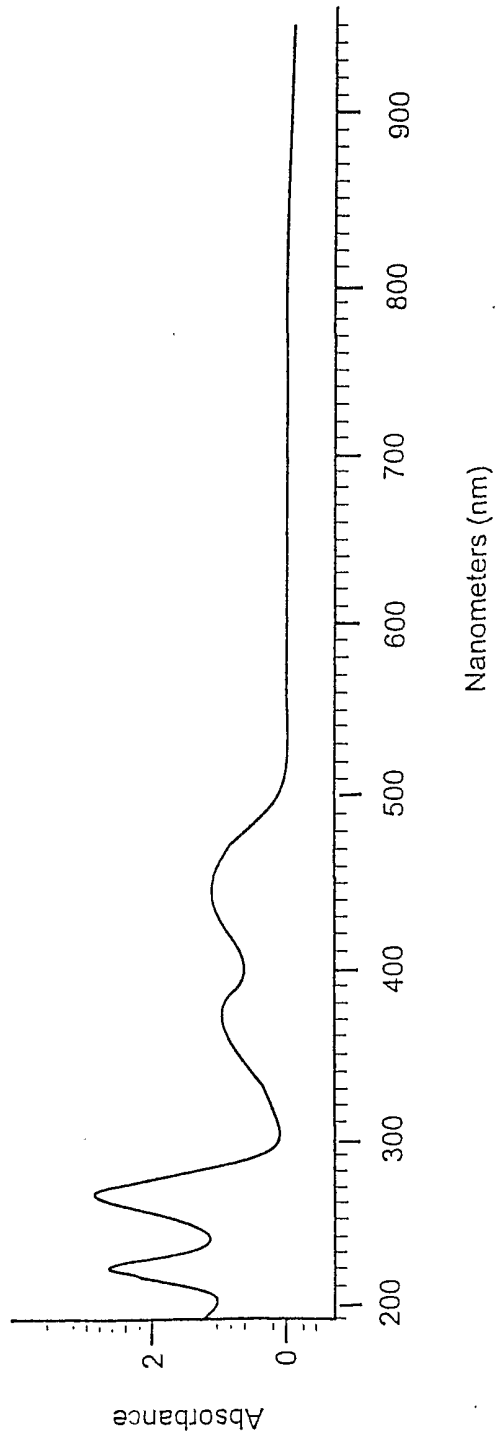

FIG. 1



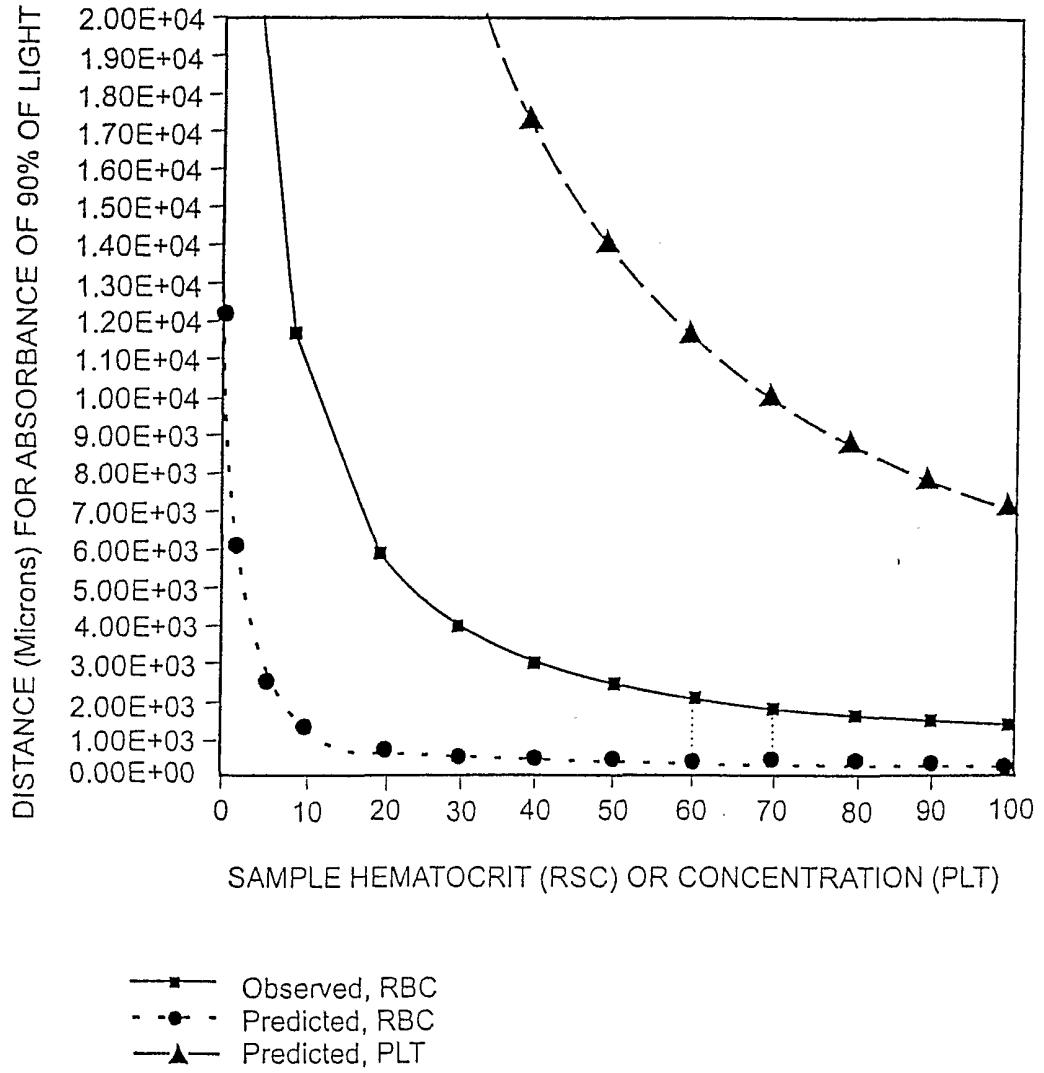

FIG. 2

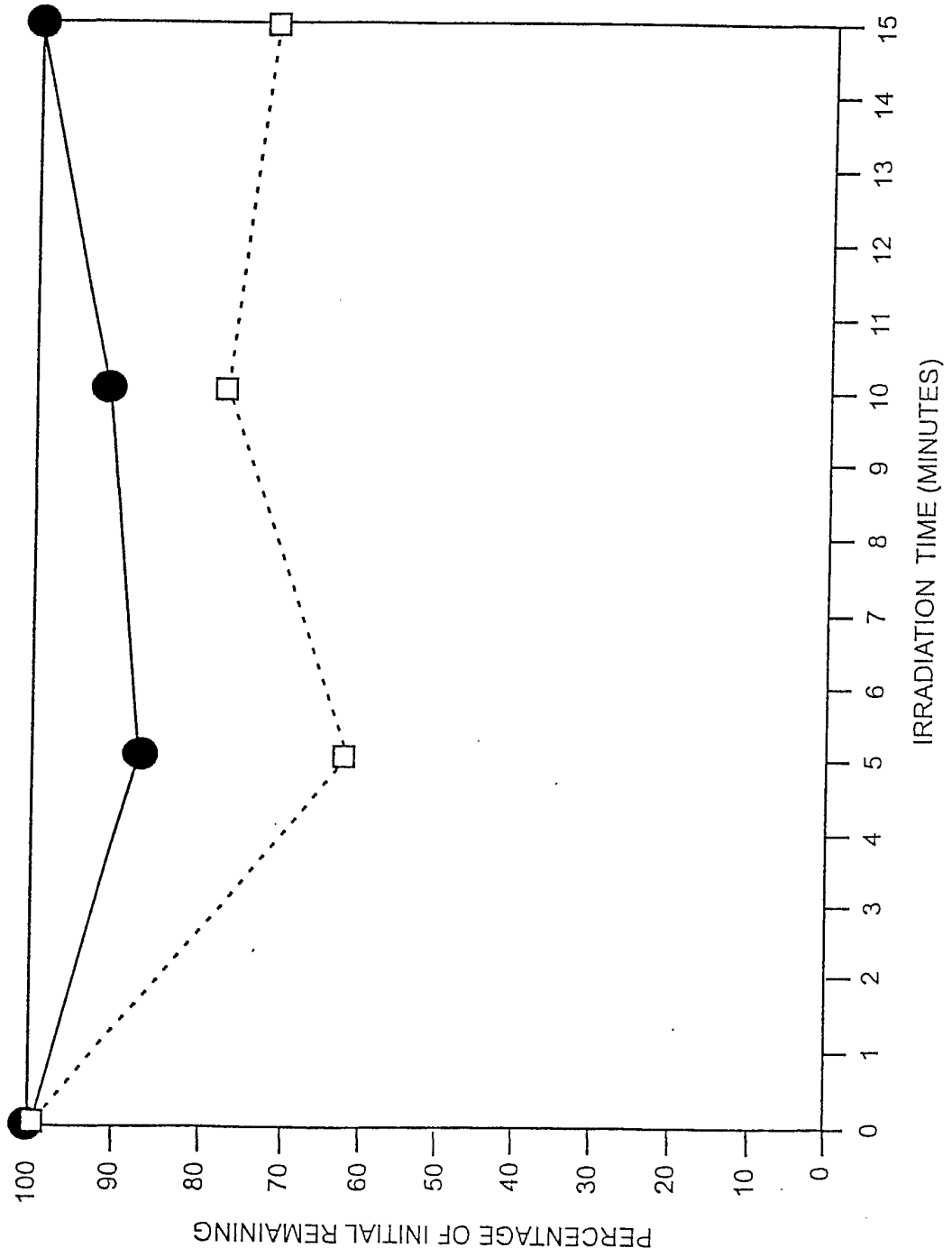

FIG. 3

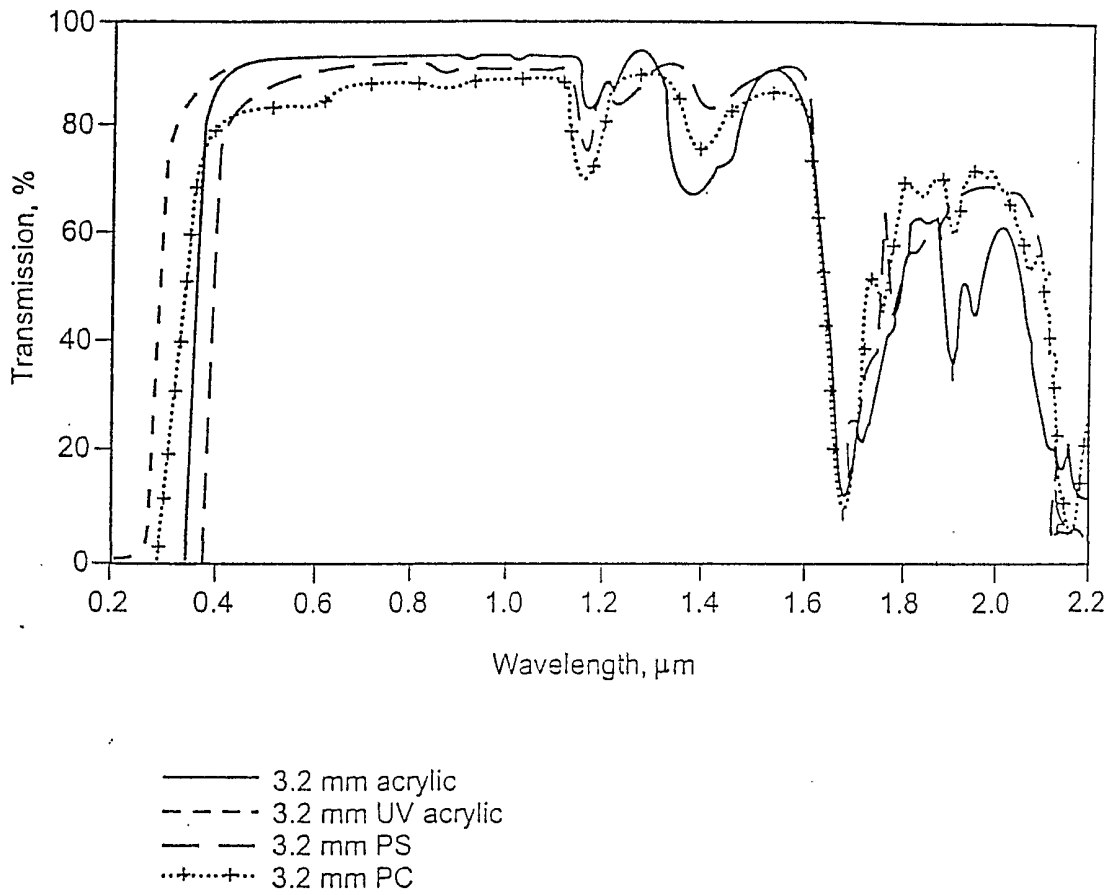

FIG. 4

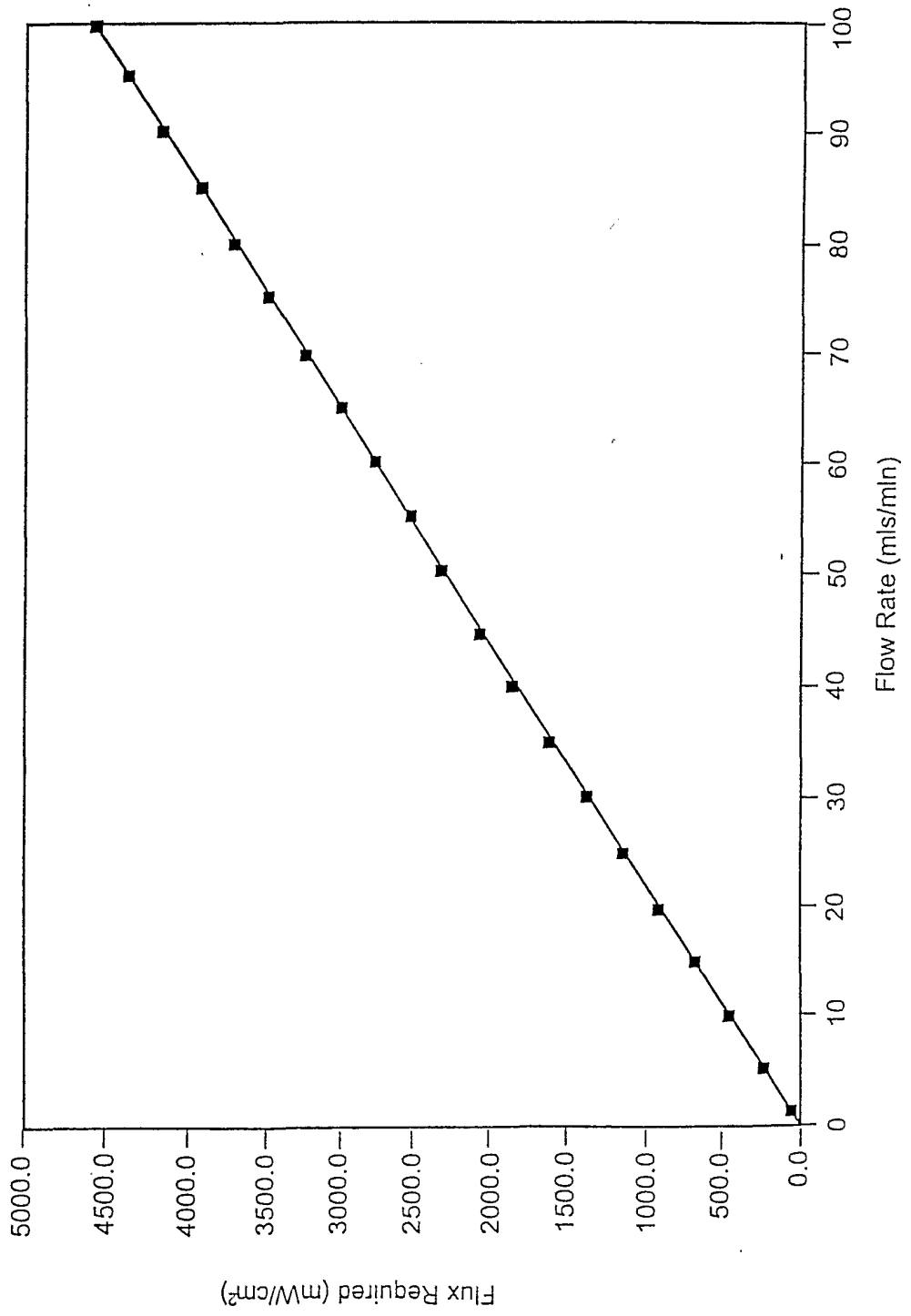

FIG. 5

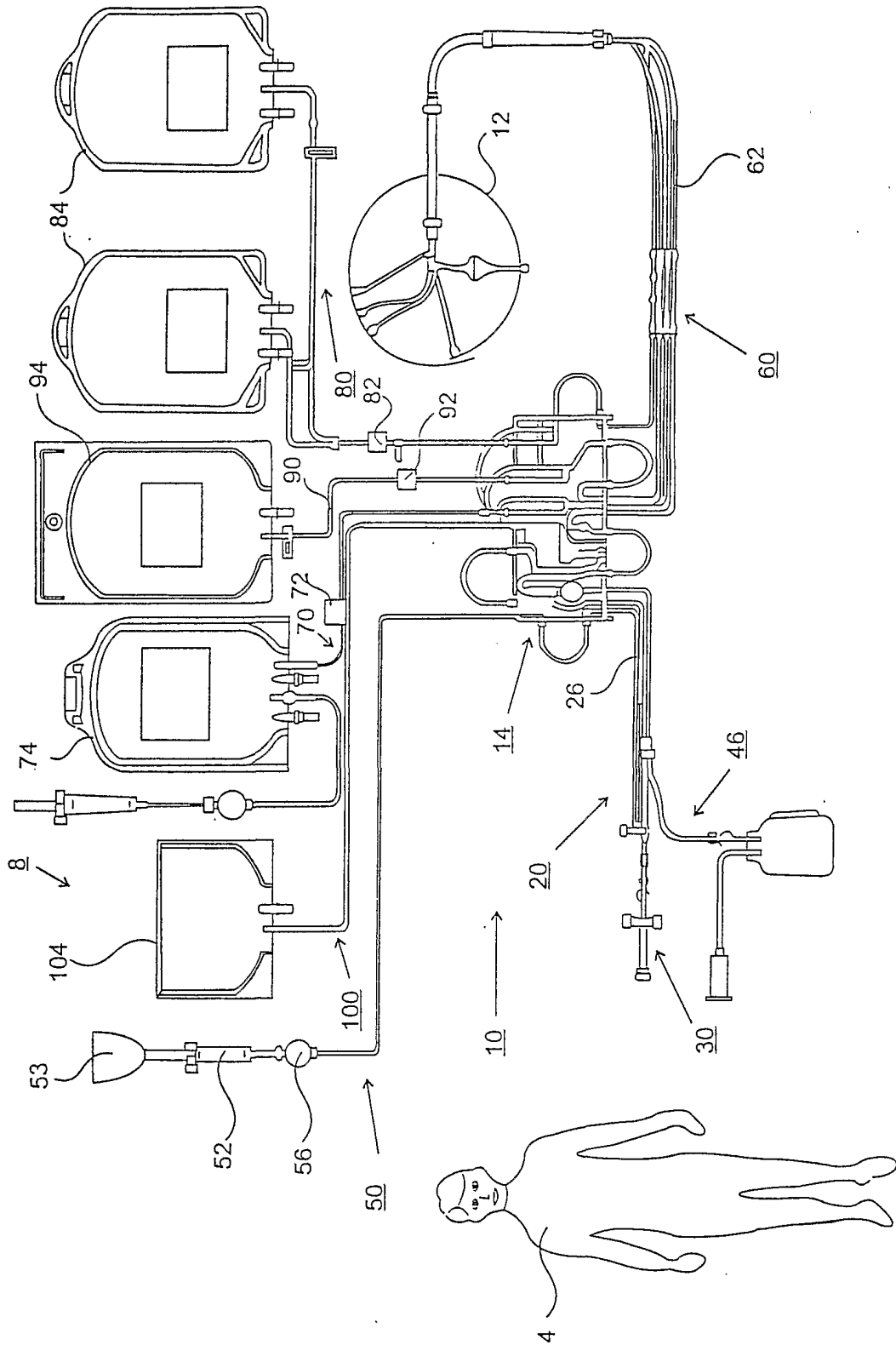

FIG. 6

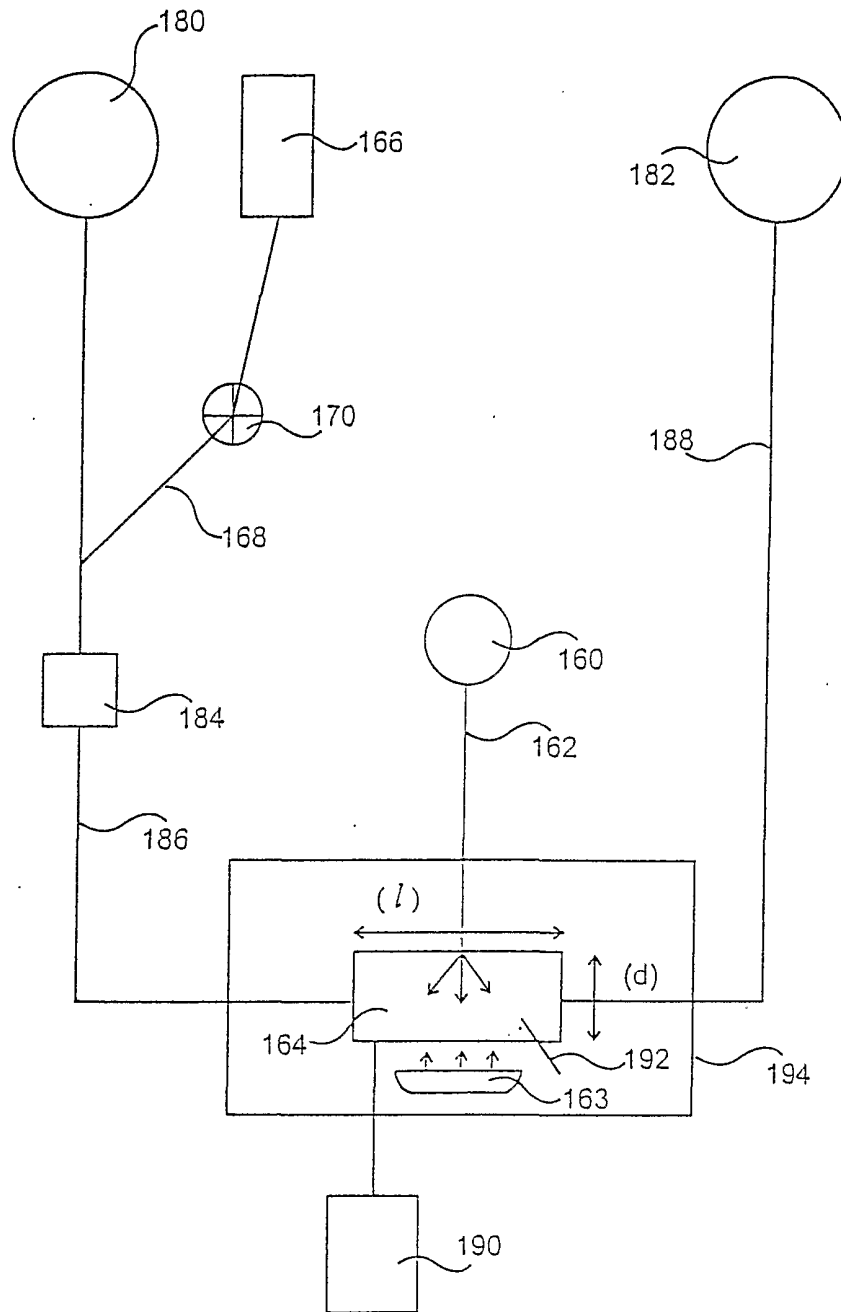

FIG. 7

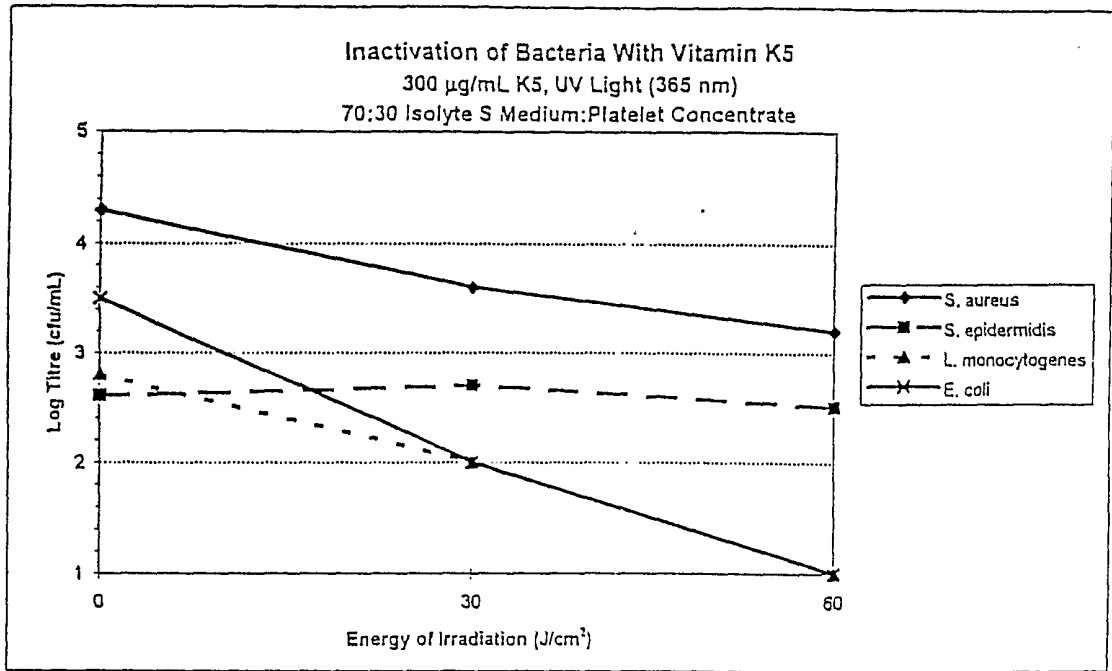

FIG. 8

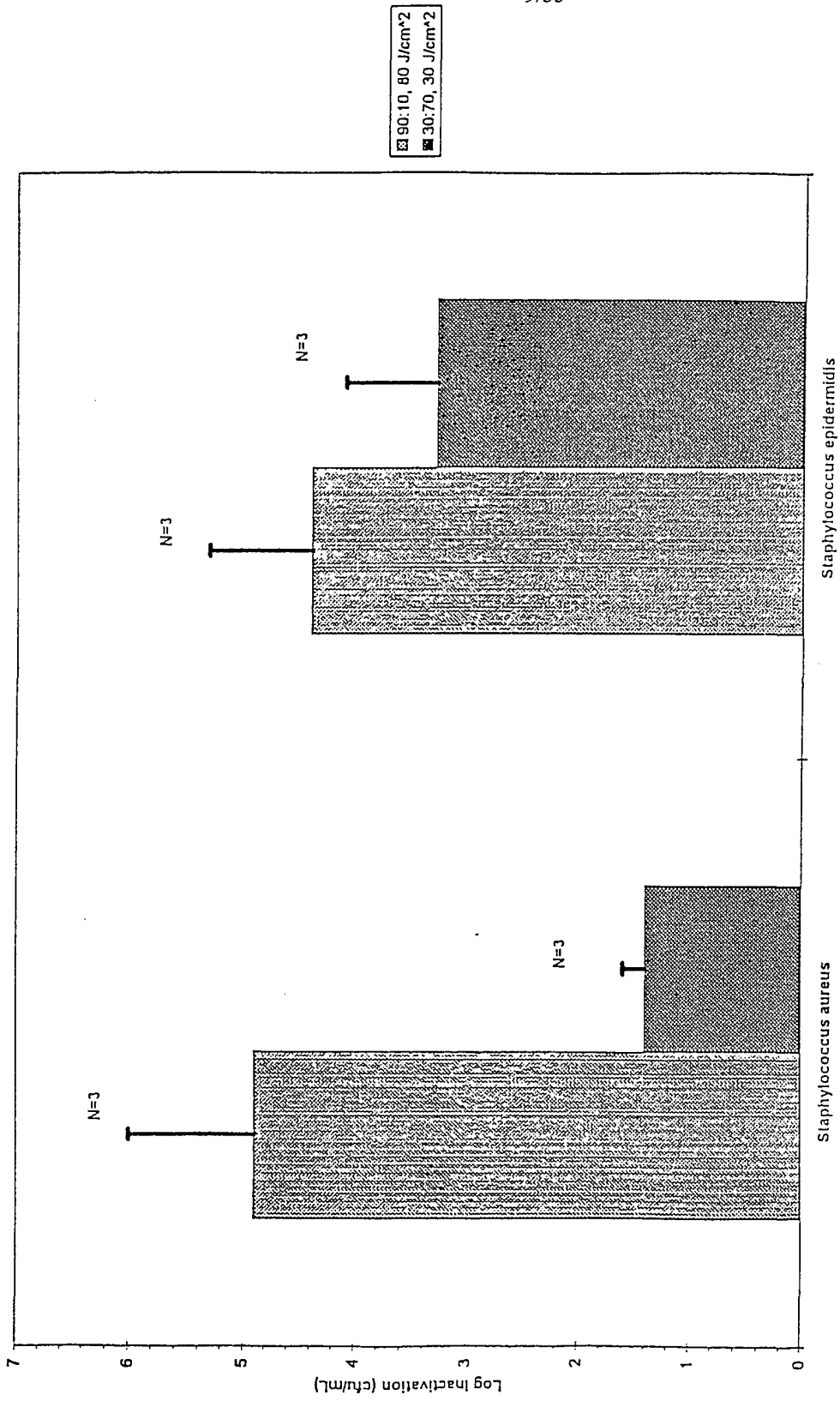

FIG. 9



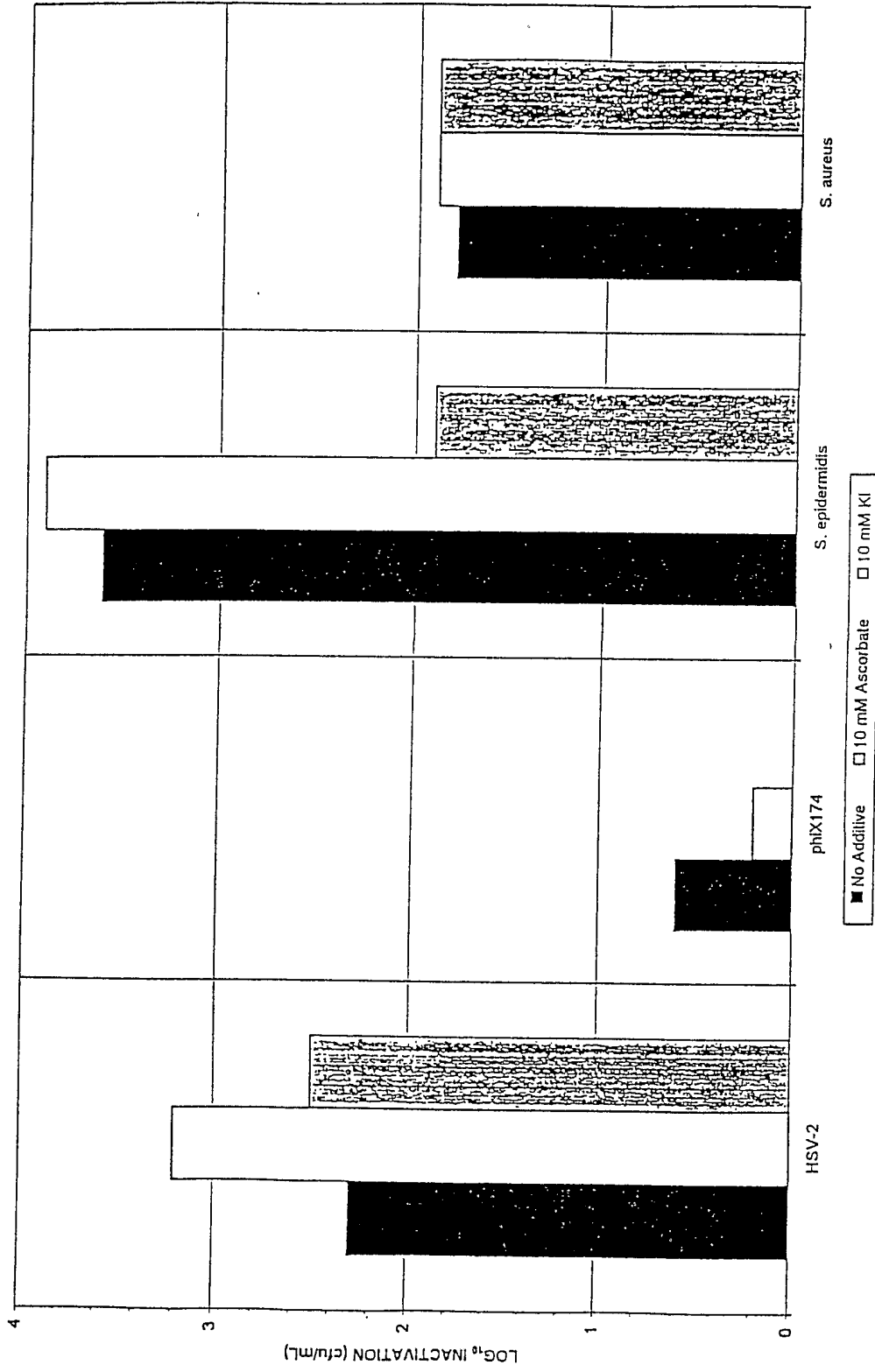

FIG. 10

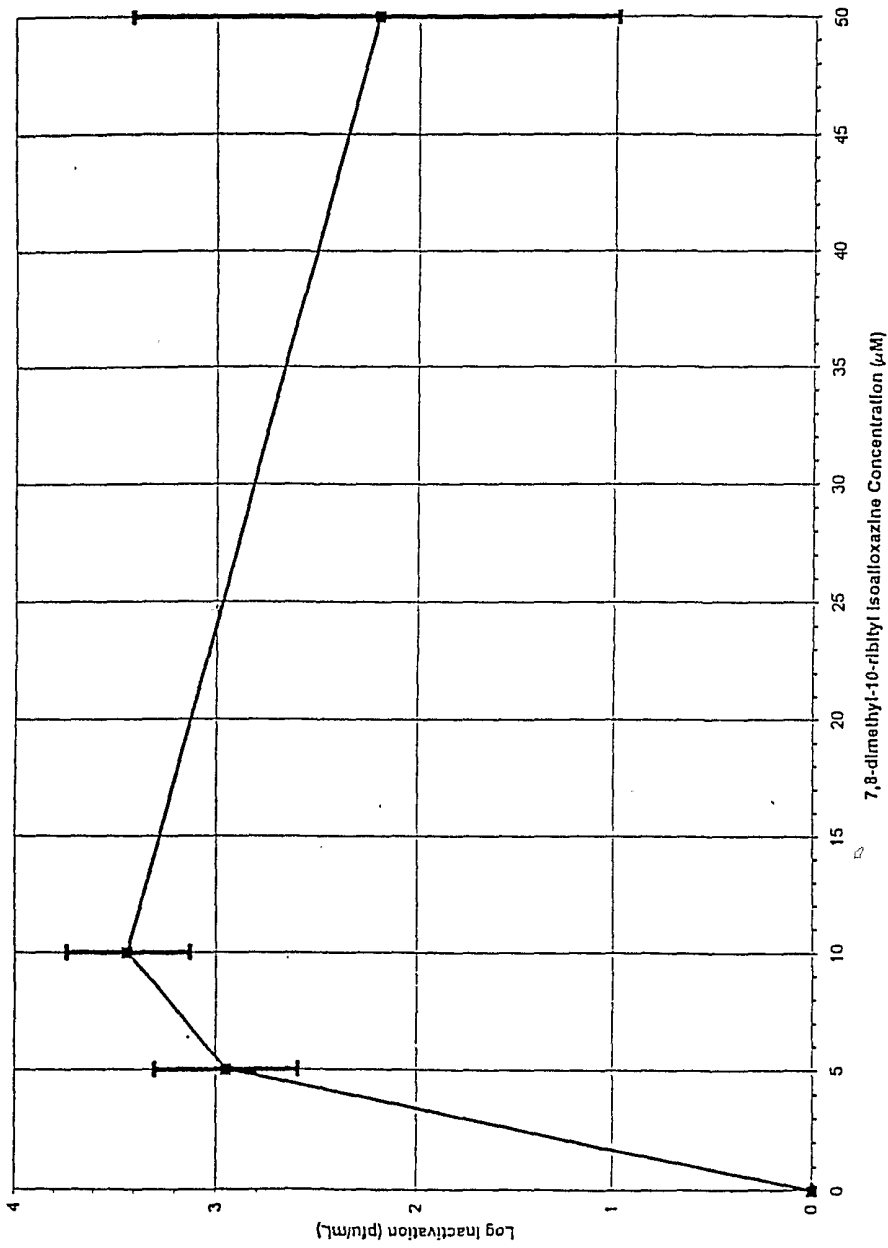

FIG. 11

12/35

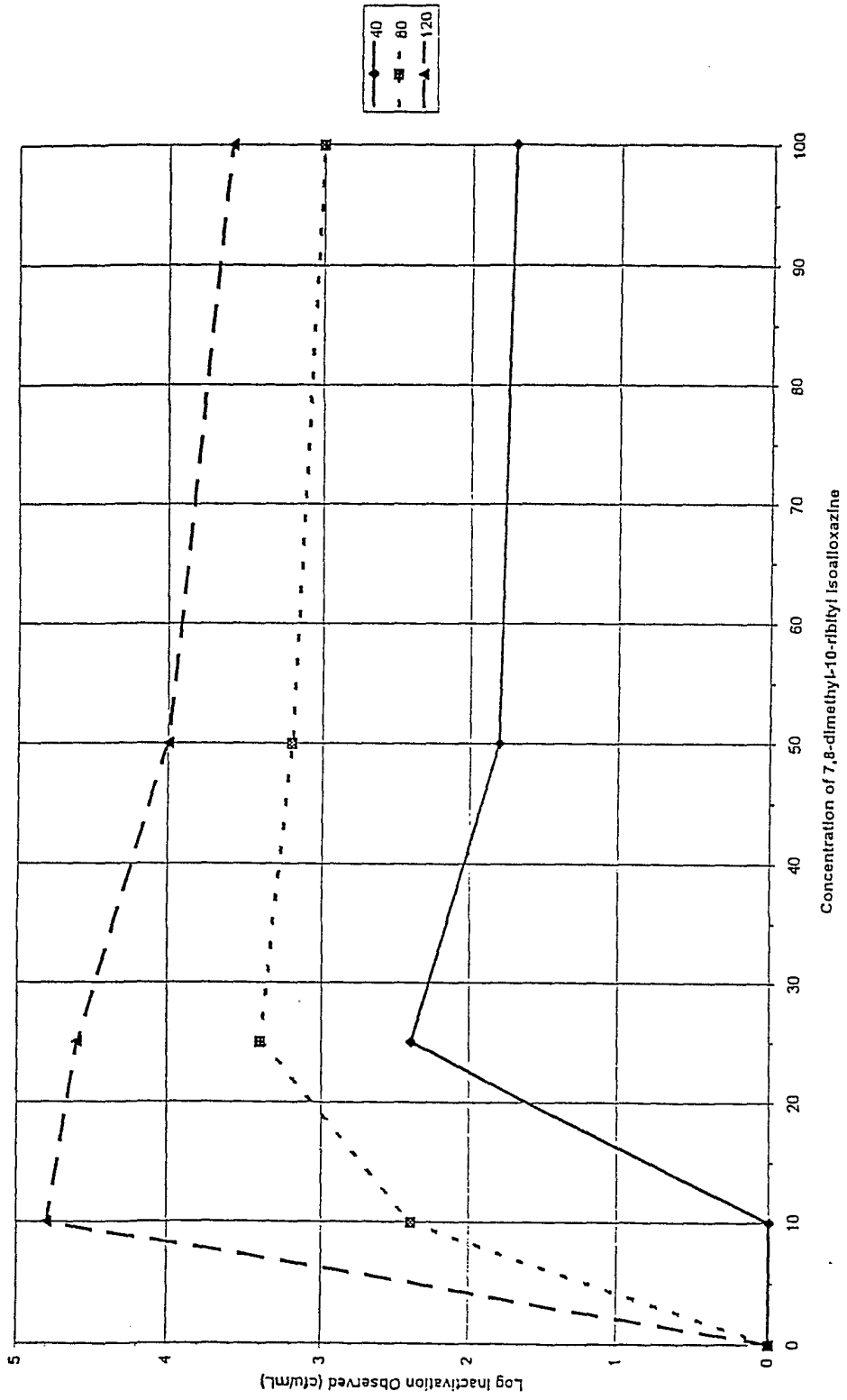

FIG. 12

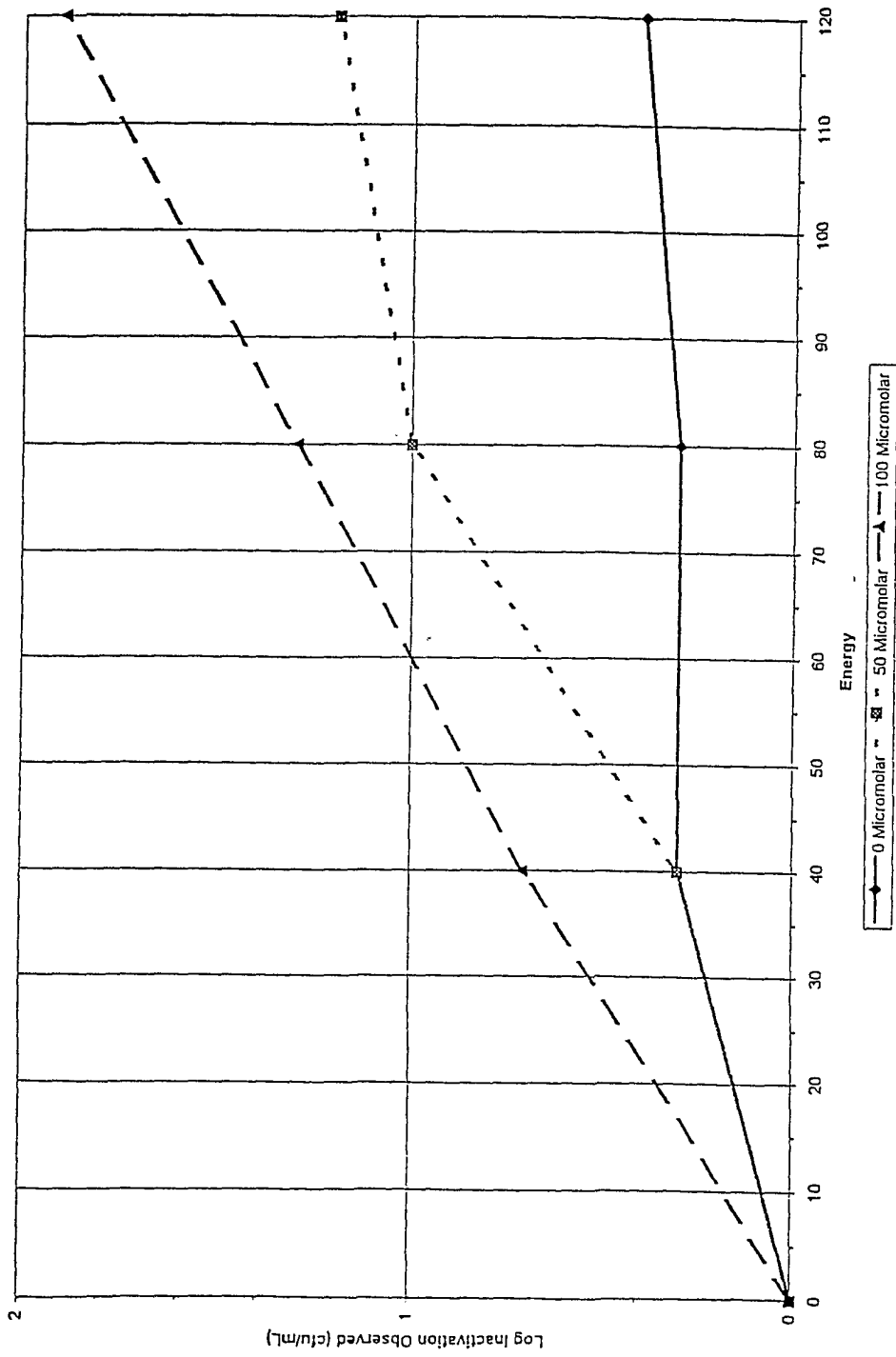

FIG. 13

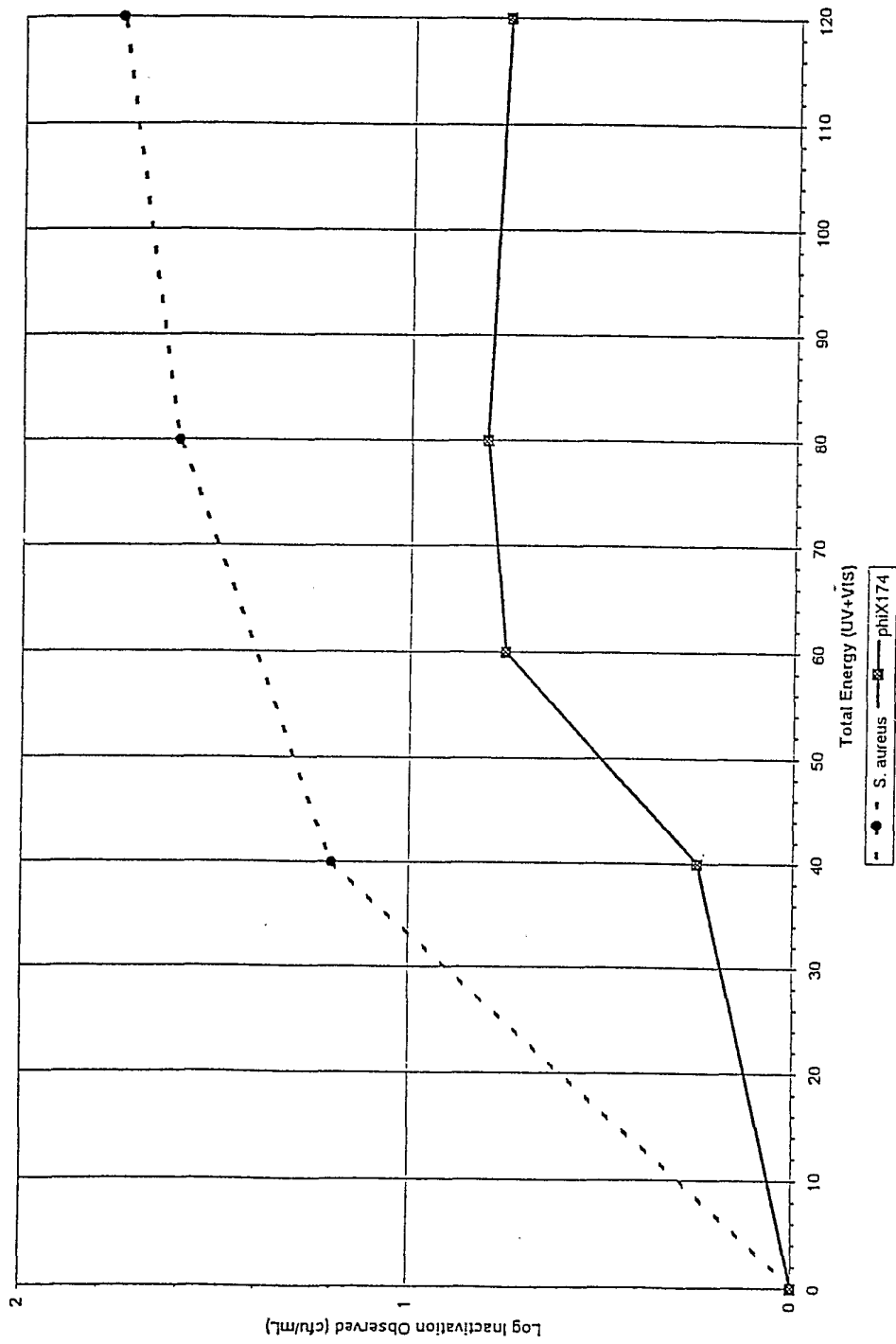

FIG. 14

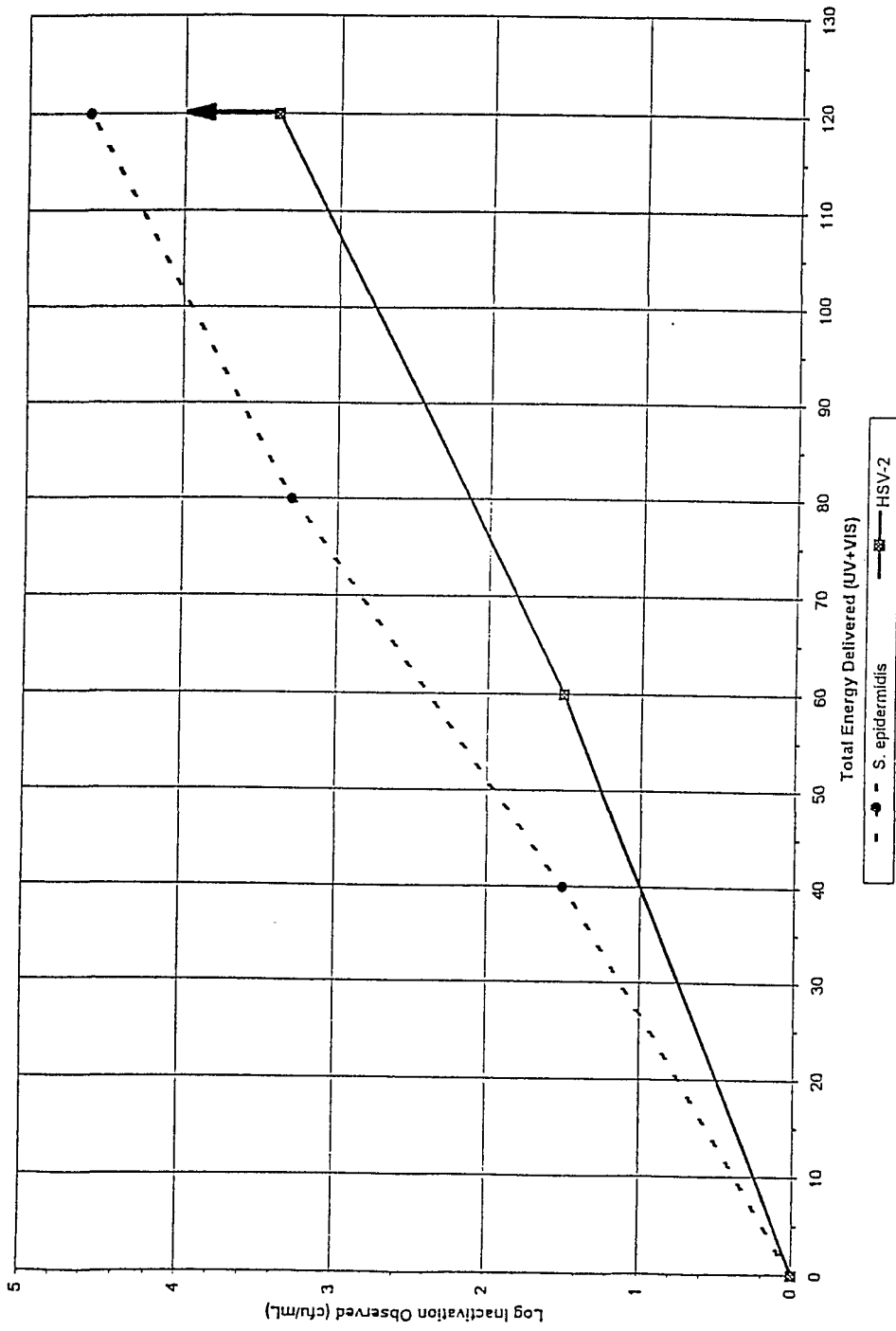

FIG. 15

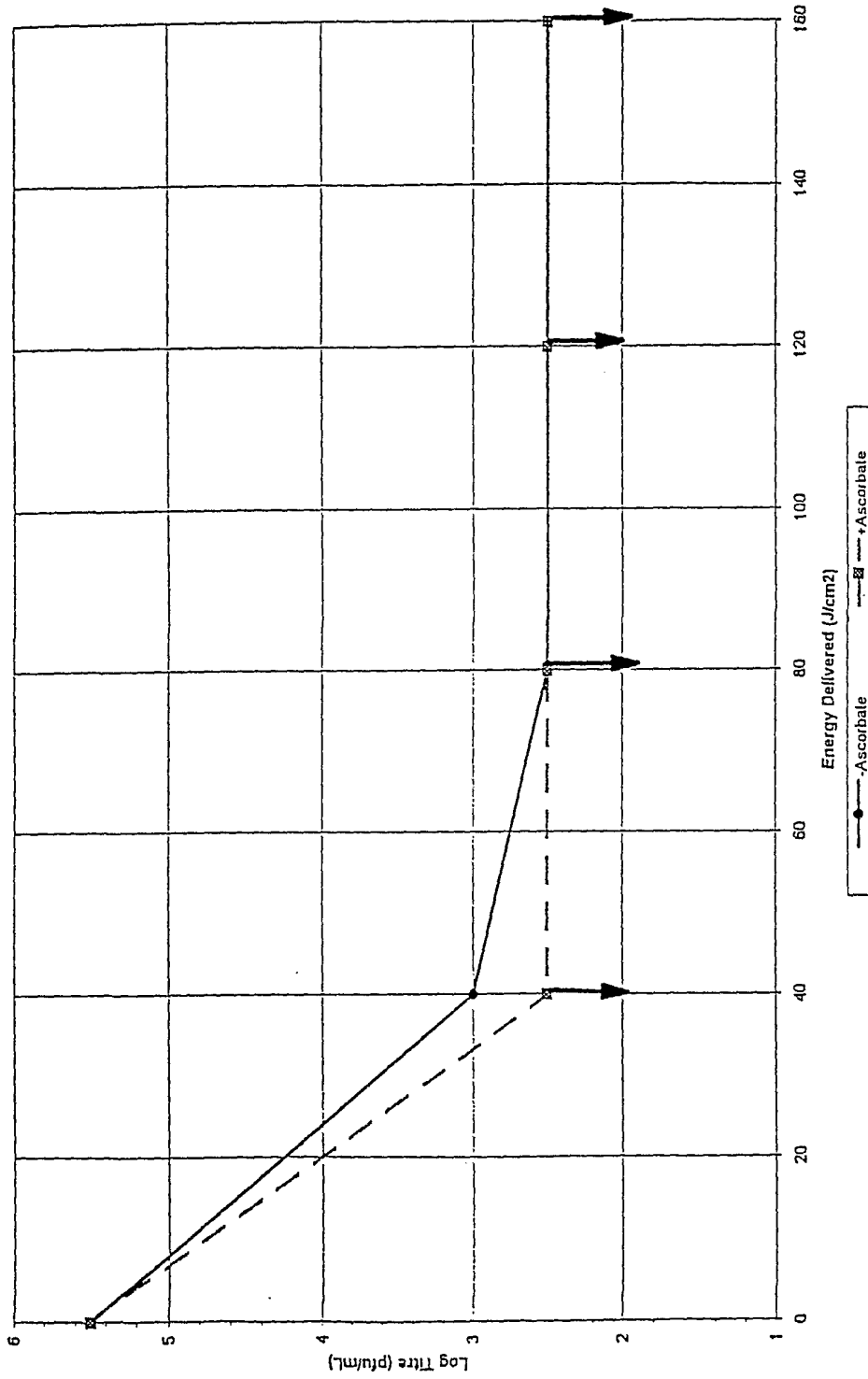

FIG. 16

17/35

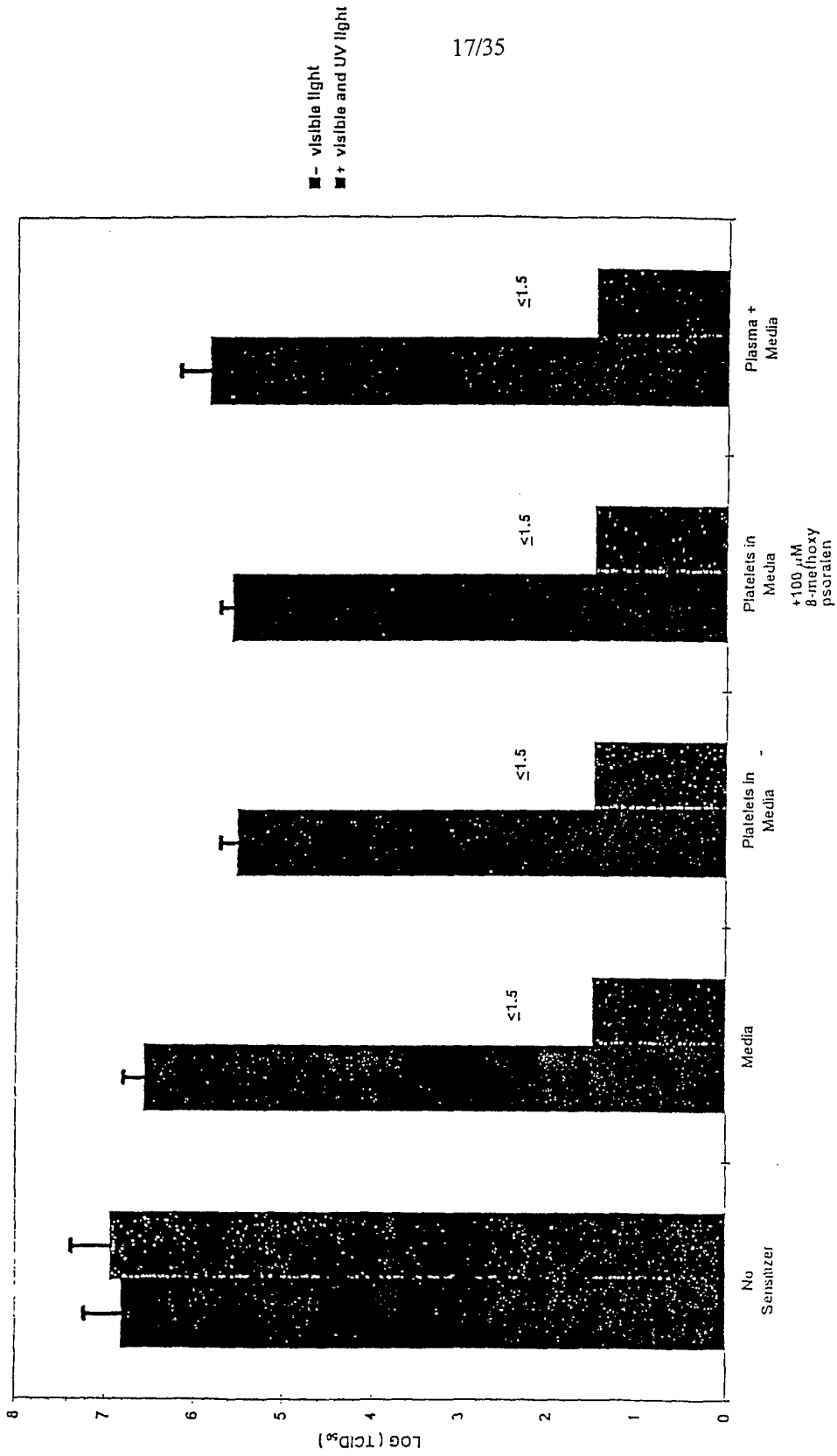

FIG. 17



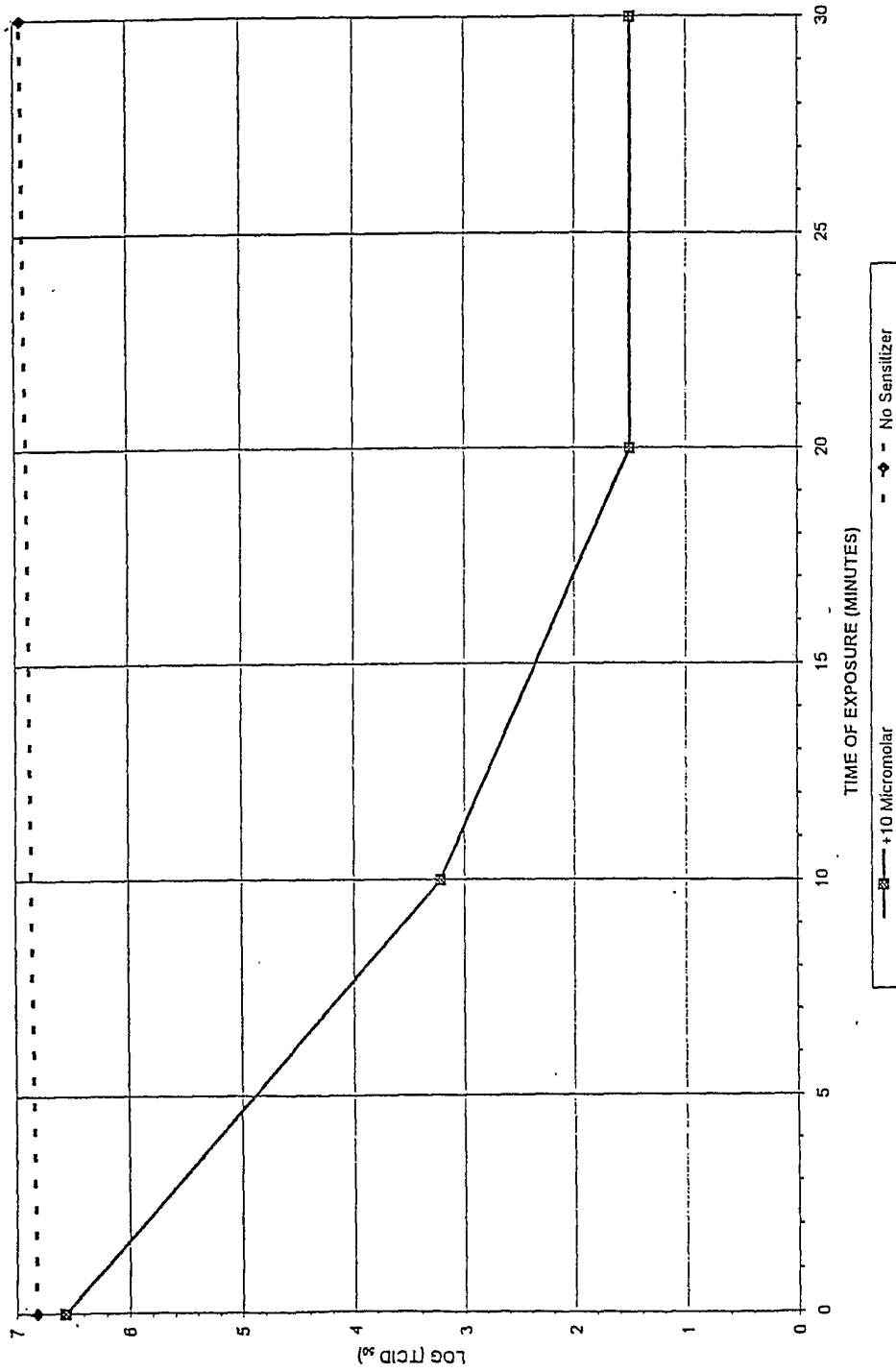

FIG. 18

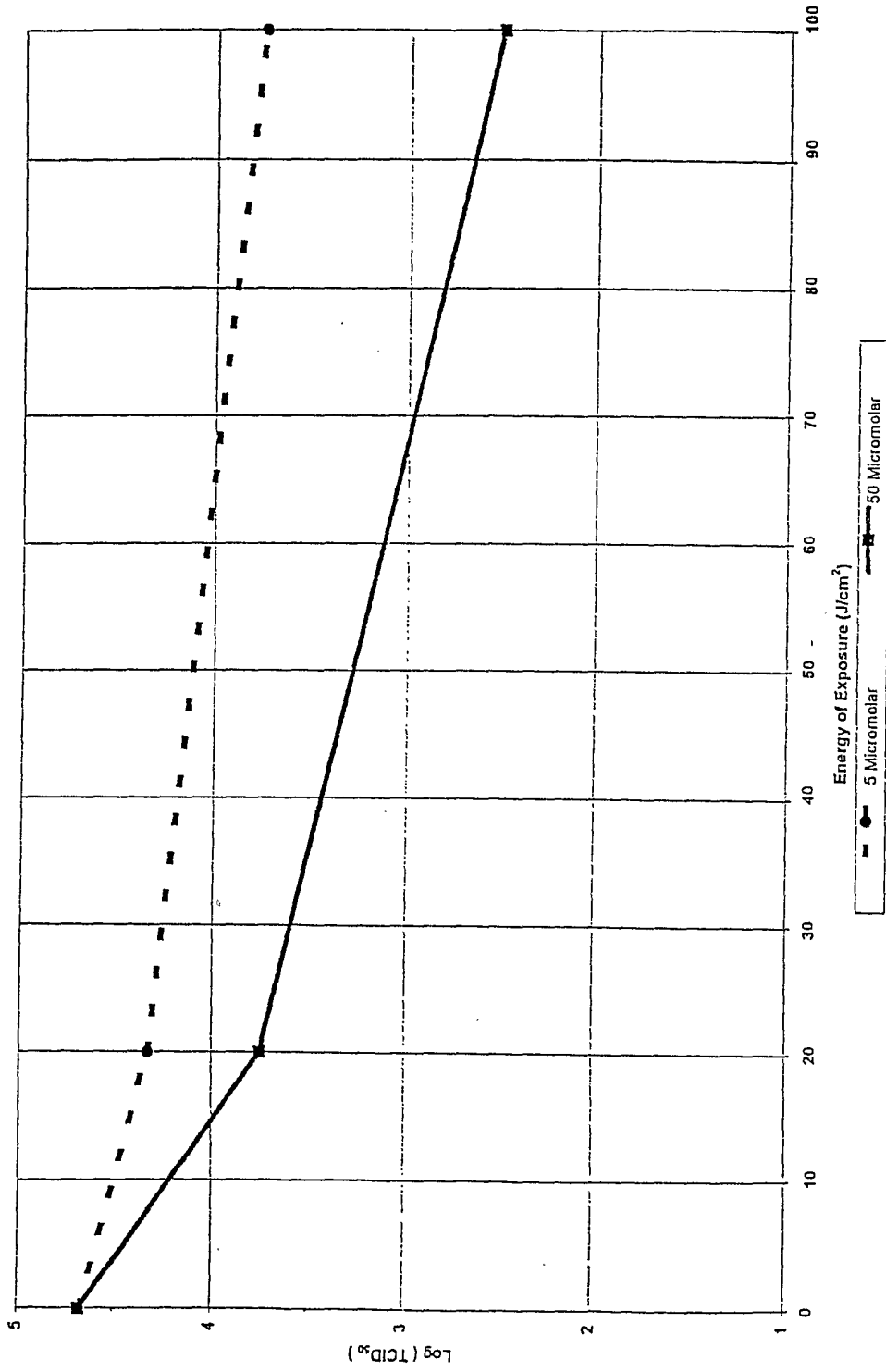

FIG. 19

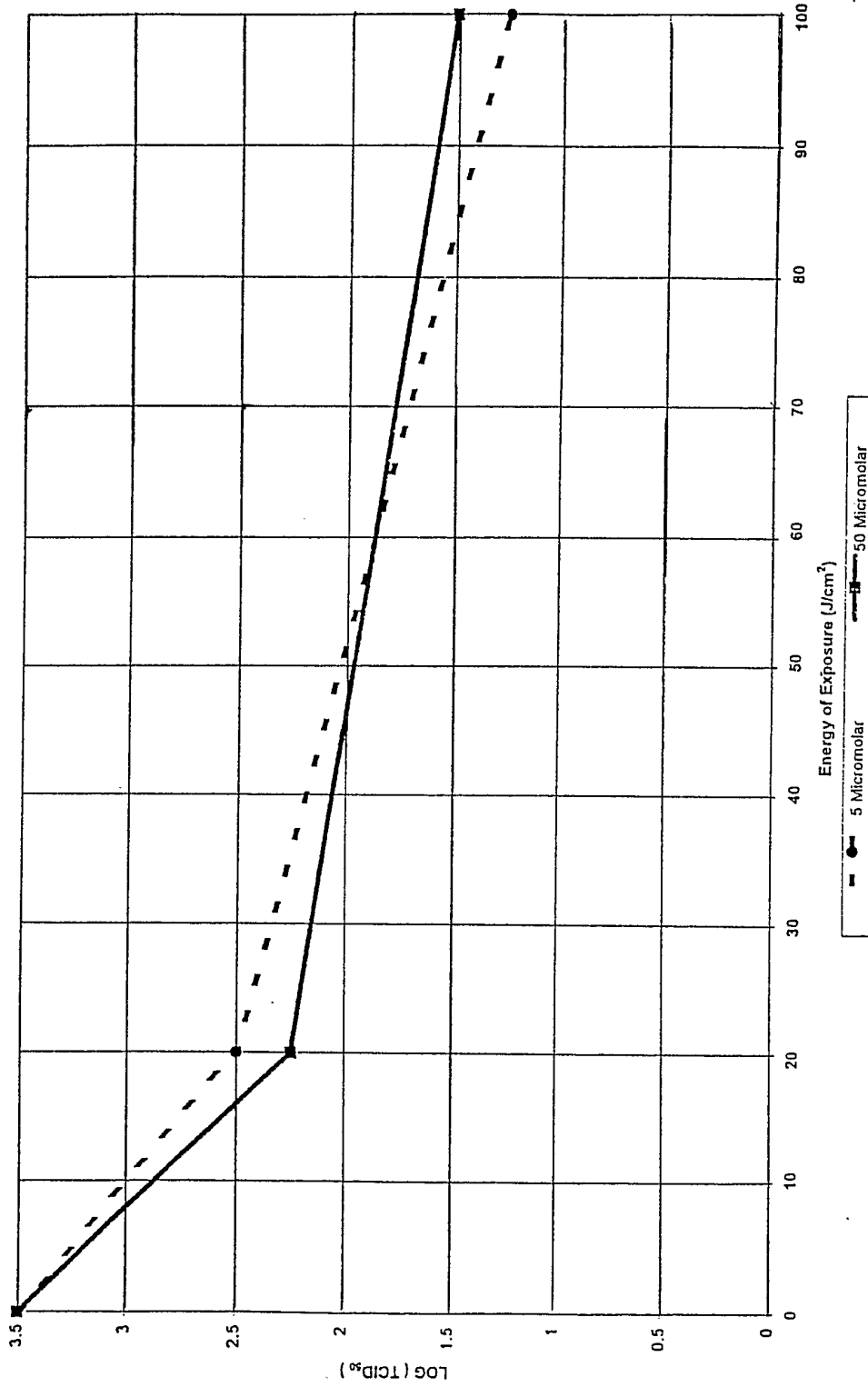

FIG. 20

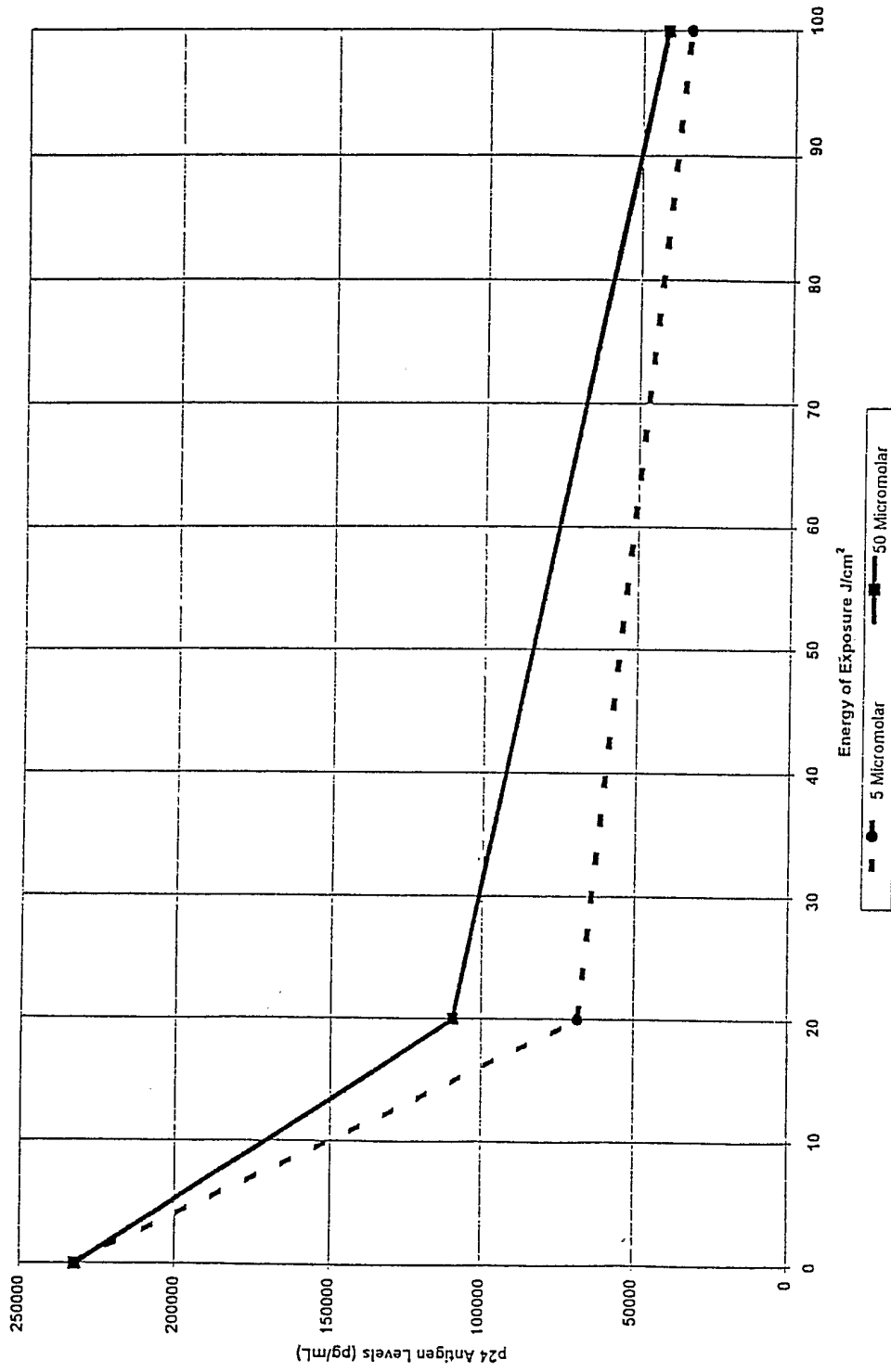

FIG. 21

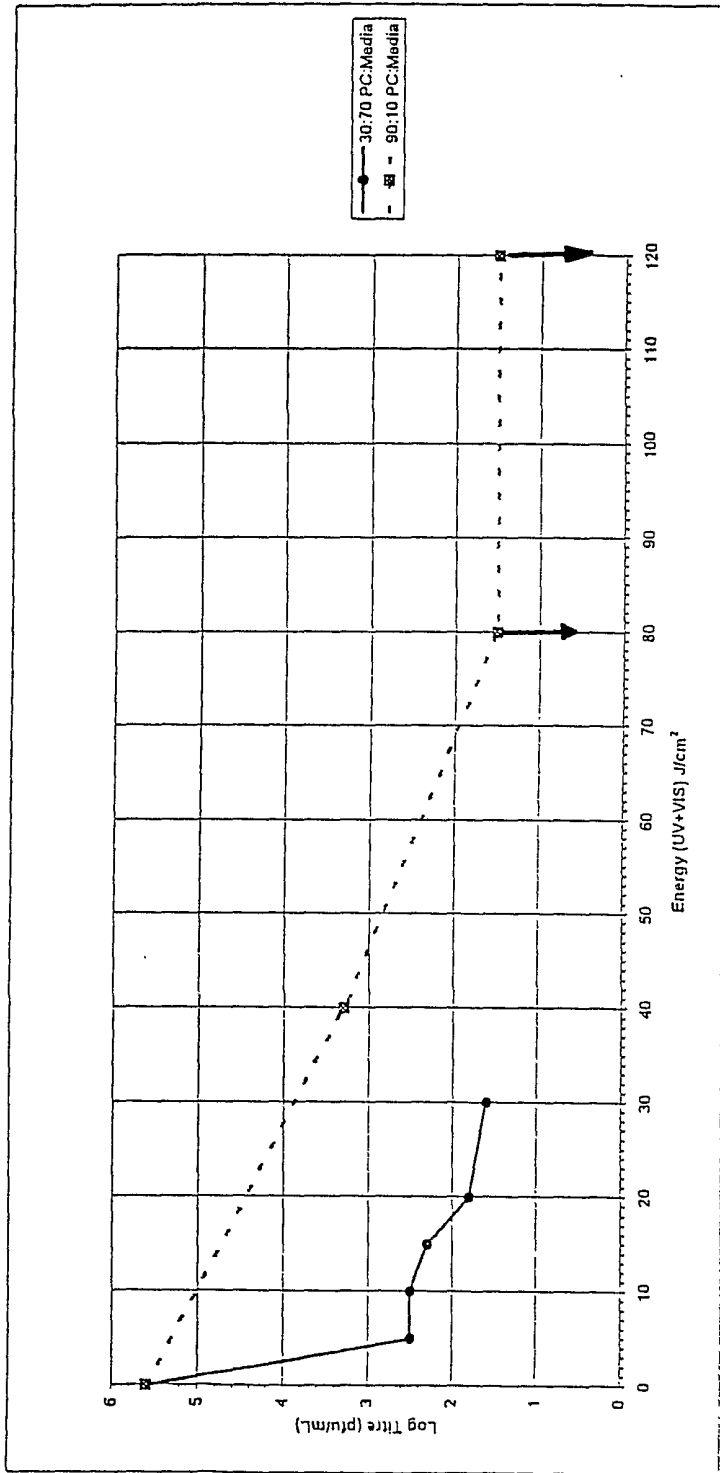

FIG. 22

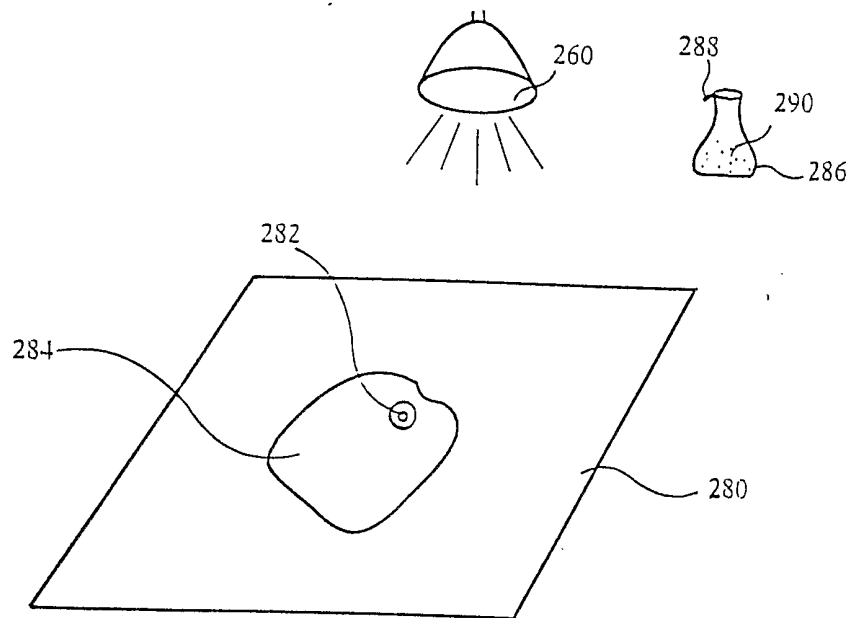

FIG. 23

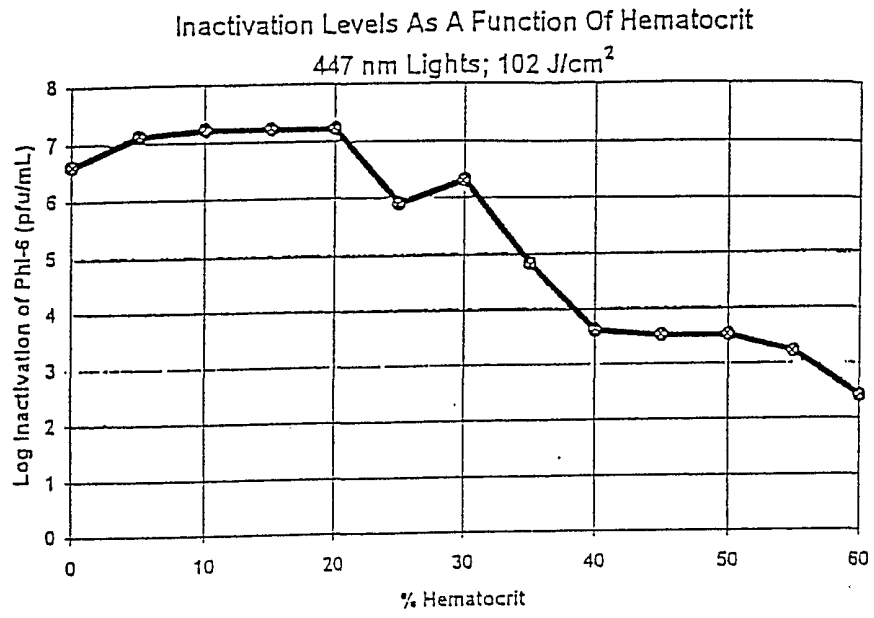

FIG. 24

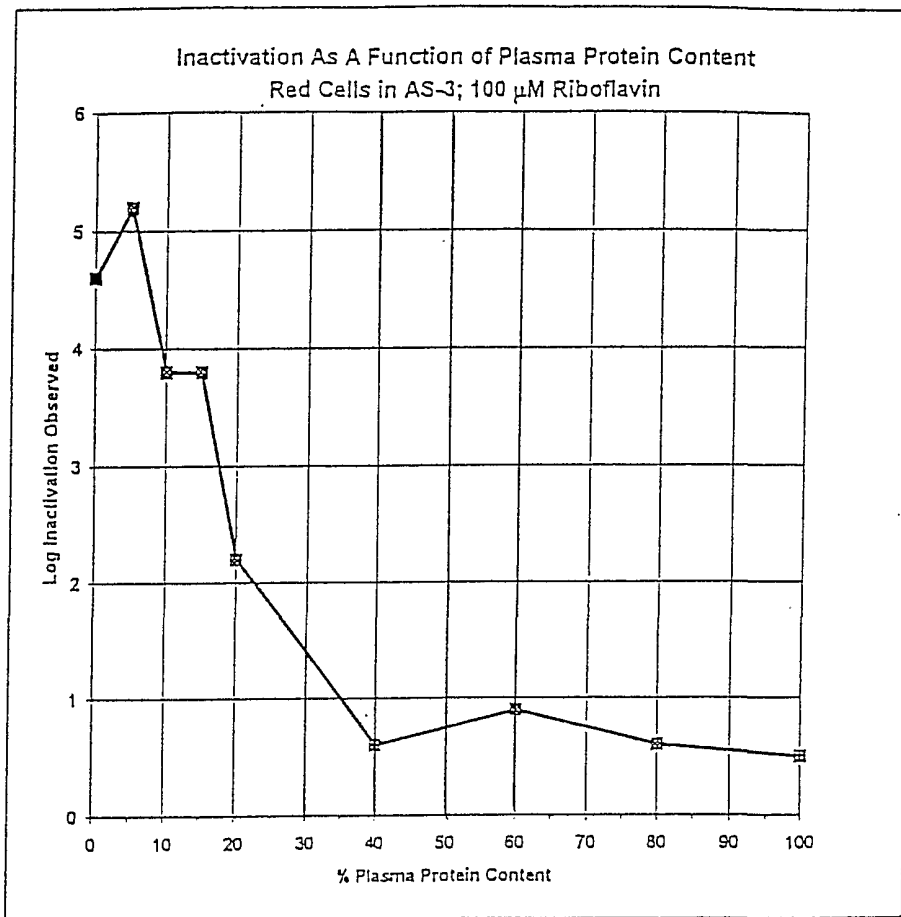

FIG. 25



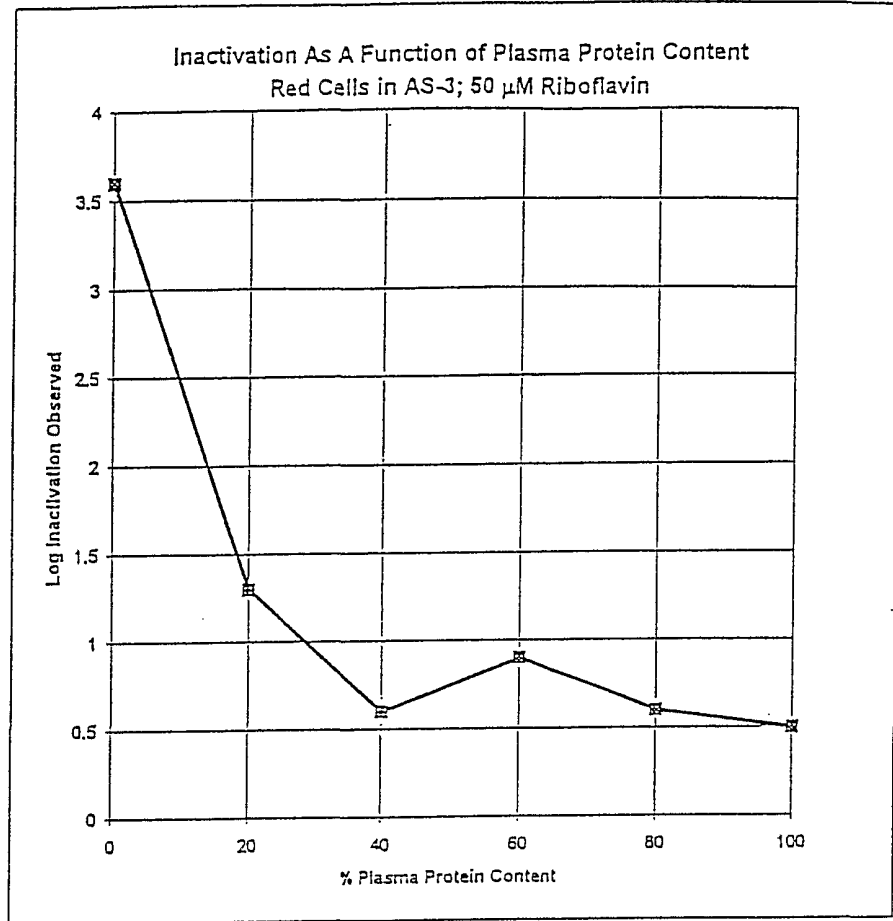

FIG. 26

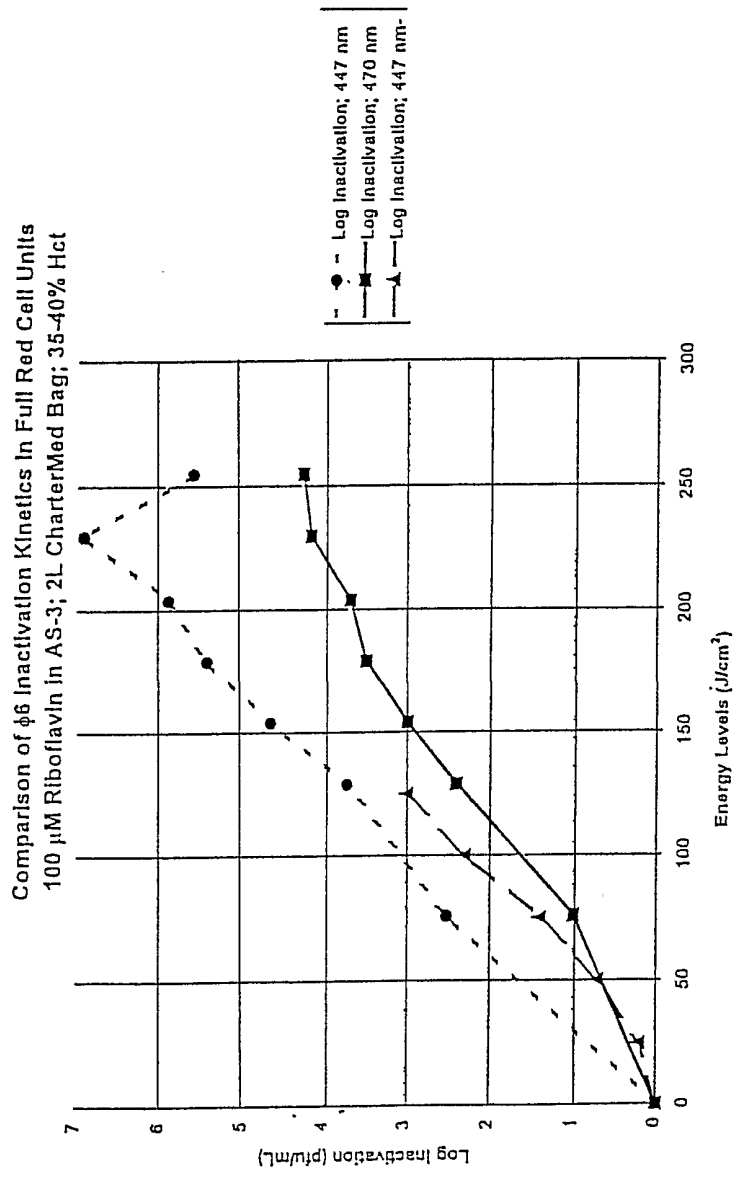

FIG. 27

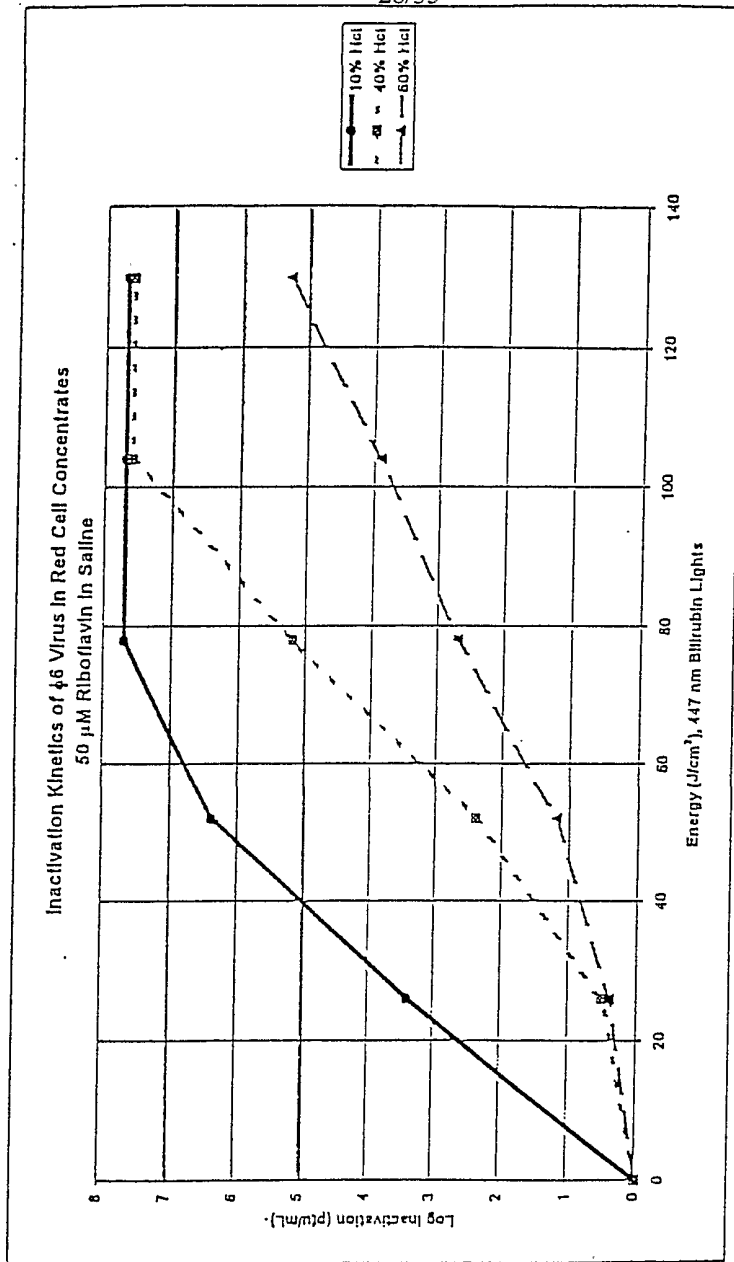

FIG. 28

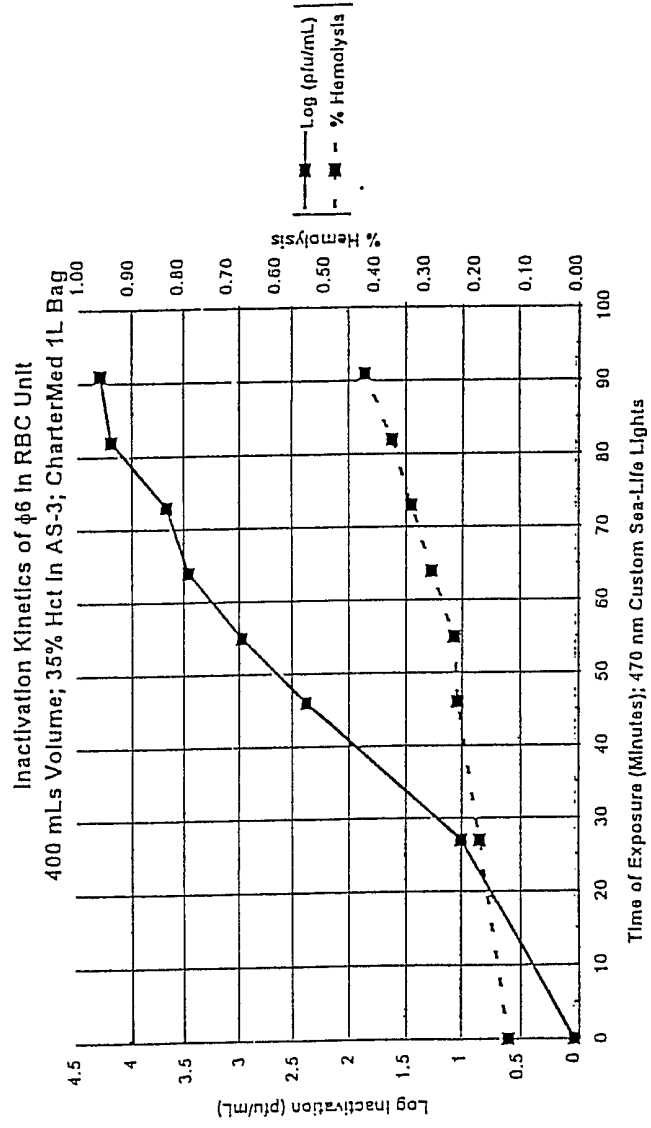

FIG. 29

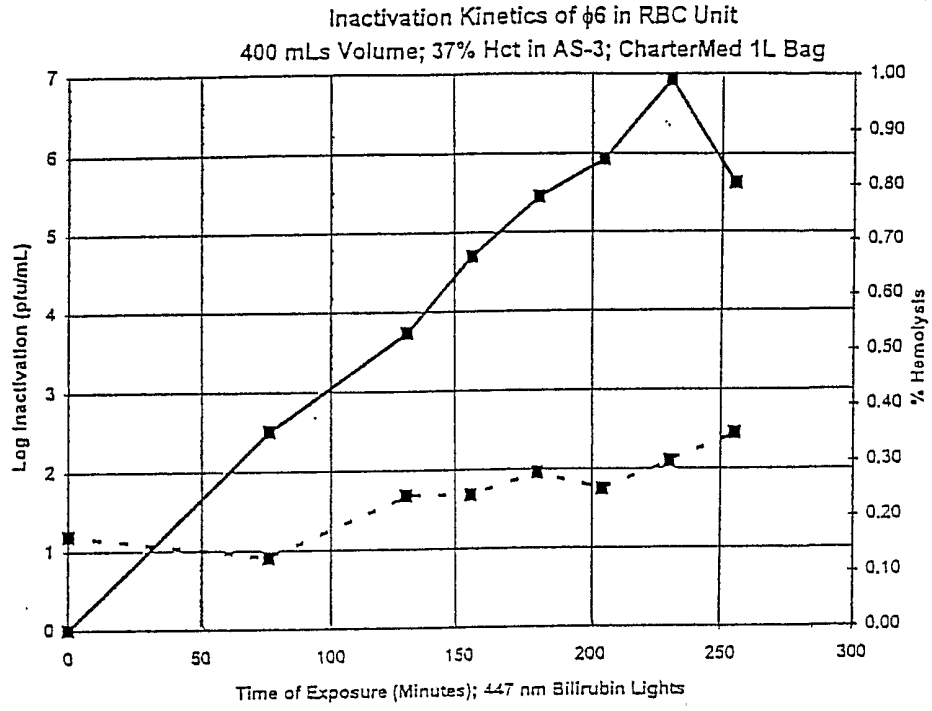

FIG. 30

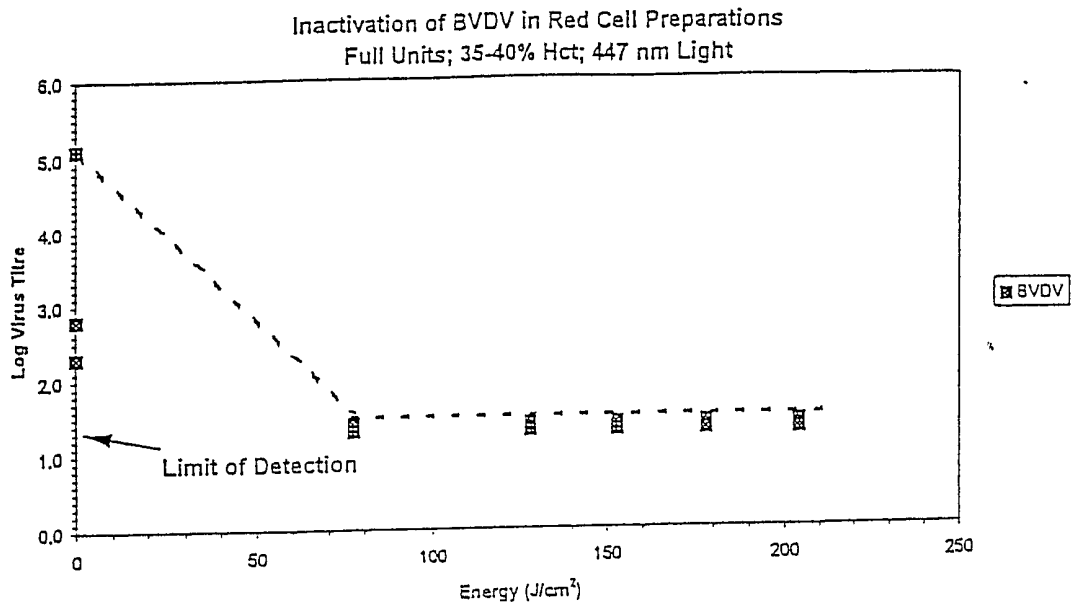

FIG. 31

32/35

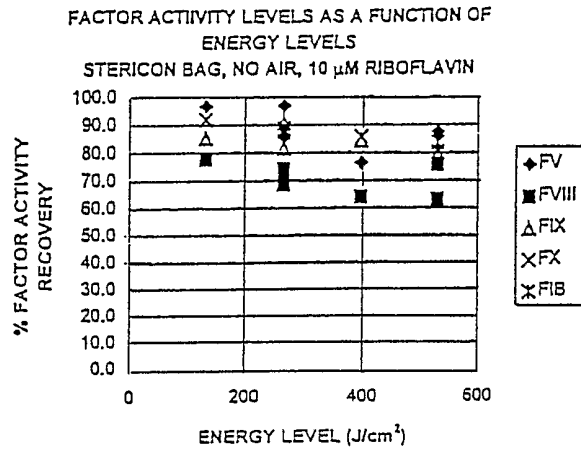

FIG. 32

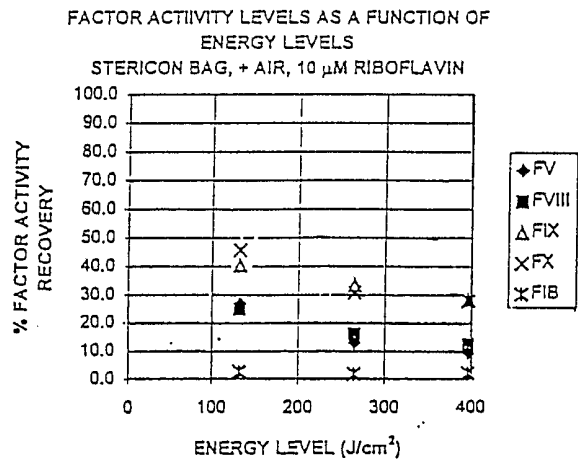

FIG. 33

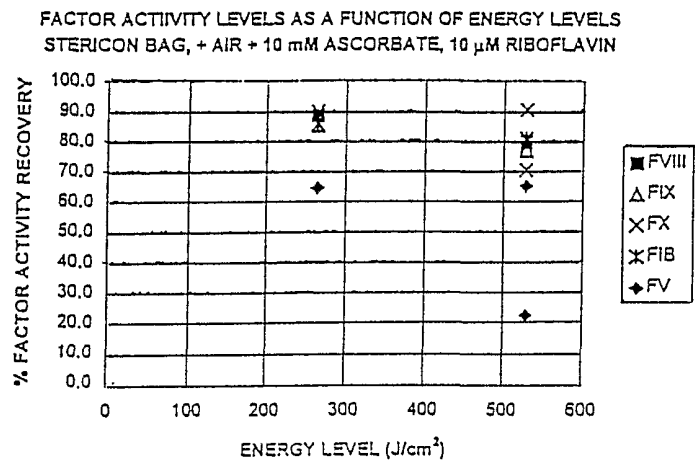

FIG. 34



34/35

Custom Sea Life "Power Compact"  
7100K Blue 28 watt Twin Tube

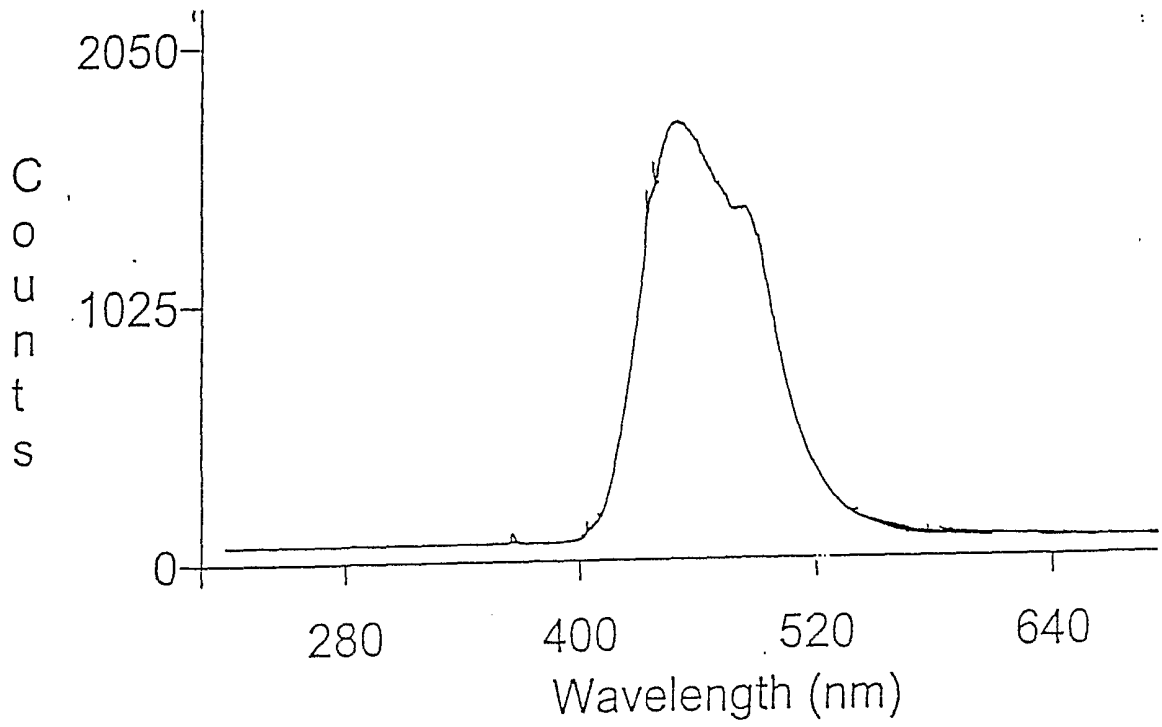

FIG. 35

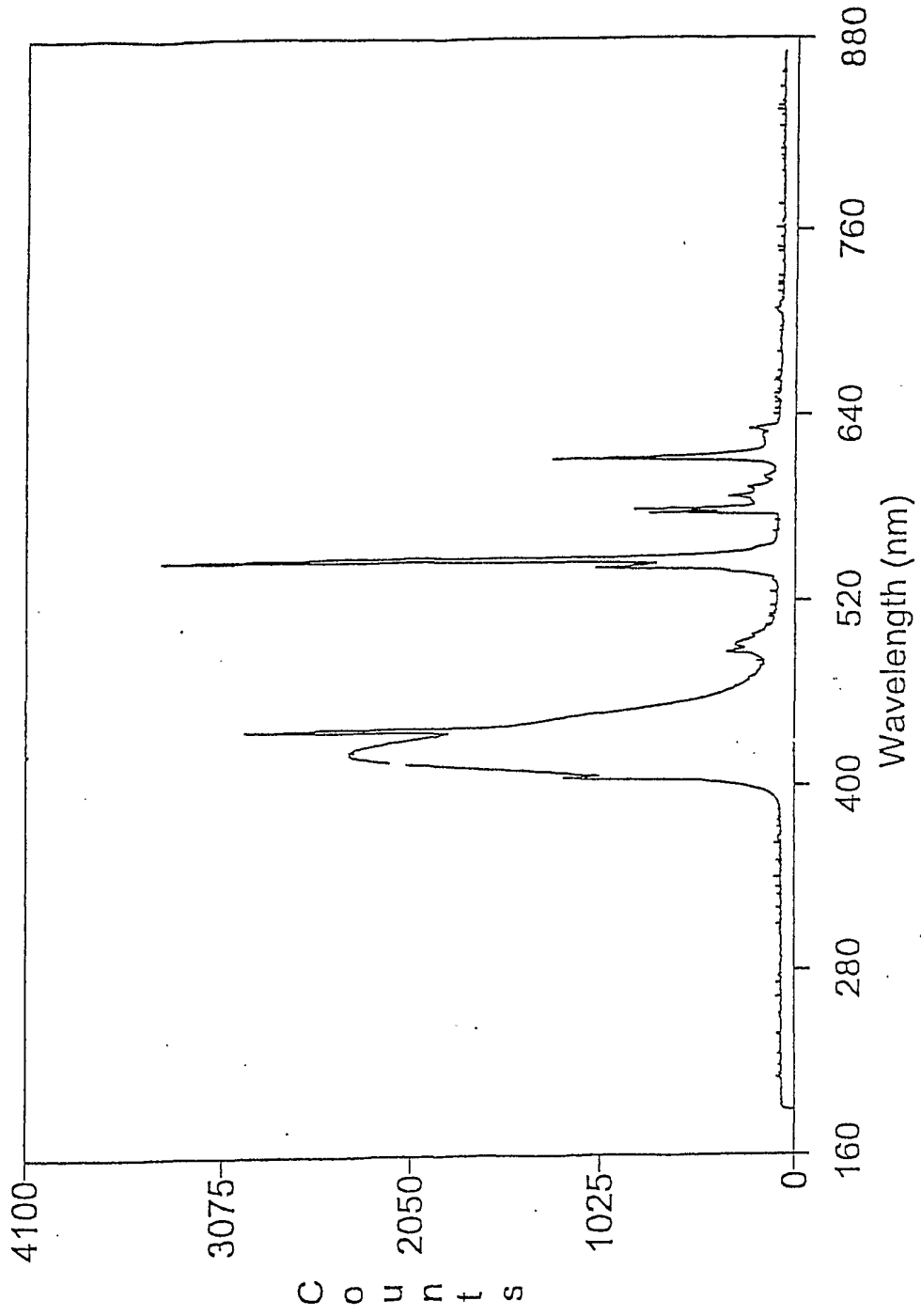

FIG. 36

INTERNATIONAL SEARCH REPORT

International Application No  
PCT/US 01/18752

<b>A. CLASSIFICATION OF SUBJECT MATTER</b> IPC 7 C07D475/14 A61L2/00 A61L2/08 A61L2/10		
According to International Patent Classification (IPC) or to both national classification and IPC		
<b>B. FIELDS SEARCHED</b> Minimum documentation searched (classification system followed by classification symbols) IPC 7 C07D A61L		
Documentation searched other than minimum documentation to the extent that such documents are included in the fields searched		
Electronic data base consulted during the international search (name of data base and, where practical, search terms used) EPO-Internal, WPI Data, PAJ		
<b>C. DOCUMENTS CONSIDERED TO BE RELEVANT</b>		
Category °	Citation of document, with indication, where appropriate, of the relevant passages	Relevant to claim No.
X	WO 00 04930 A (COBE LAB) 3 February 2000 (2000-02-03) cited in the application page 42, line 14 - line 20 page 22, line 10 - line 26 claims	1-108
X	US 5 360 734 A (NEYNDORFF HERMA C ET AL) 1 November 1994 (1994-11-01) cited in the application claims	1-108
<input type="checkbox"/> Further documents are listed in the continuation of box C. <input checked="" type="checkbox"/> Patent family members are listed in annex.		
° Special categories of cited documents :		
<ul style="list-style-type: none"> <li>*A* document defining the general state of the art which is not considered to be of particular relevance</li> <li>*E* earlier document but published on or after the international filing date</li> <li>*L* document which may throw doubts on priority claim(s) or which is cited to establish the publication date of another citation or other special reason (as specified)</li> <li>*O* document referring to an oral disclosure, use, exhibition or other means</li> <li>*P* document published prior to the international filing date but later than the priority date claimed</li> <li>*T* later document published after the international filing date or priority date and not in conflict with the application but cited to understand the principle or theory underlying the invention</li> <li>*X* document of particular relevance; the claimed invention cannot be considered novel or cannot be considered to involve an inventive step when the document is taken alone</li> <li>*Y* document of particular relevance; the claimed invention cannot be considered to involve an inventive step when the document is combined with one or more other such documents, such combination being obvious to a person skilled in the art.</li> <li>*&amp;* document member of the same patent family</li> </ul>		
Date of the actual completion of the international search 2 November 2001		Date of mailing of the international search report 15/11/2001
Name and mailing address of the ISA European Patent Office, P.B. 5818 Patentlaan 2 NL - 2280 HV Rijswijk Tel. (+31-70) 340-2040, Tx. 31 651 epo nl, Fax: (+31-70) 340-3016		Authorized officer Thornton, S

## INTERNATIONAL SEARCH REPORT

Information on patent family members

International Application No

PCT/US 01/18752

Patent document cited in search report		Publication date	Patent family member(s)	Publication date
WO 0004930	A	03-02-2000	US 6258577 B1	10-07-2001
			AU 5219899 A	14-02-2000
			BG 104362 A	30-04-2001
			CN 1287496 T	14-03-2001
			EP 1047458 A2	02-11-2000
			HU 0004907 A2	28-05-2001
			NO 20001440 A	19-05-2000
			PL 340630 A1	12-02-2001
			SK 5832000 A3	18-01-2001
			WO 0004930 A2	03-02-2000
			US 6277337 B1	21-08-2001
US 5360734	A	01-11-1994	US 5597722 A	28-01-1997
			AU 650998 B2	07-07-1994
			AU 2257792 A	25-01-1993
			CA 2089005 A1	22-12-1992
			DE 69221828 D1	02-10-1997
			DE 69221828 T2	09-04-1998
			EP 0544895 A1	09-06-1993
			ES 2110002 T3	01-02-1998
			JP 2811371 B2	15-10-1998
			JP 6500805 T	27-01-1994
			MX 9203042 A1	01-07-1993
			WO 9300005 A1	07-01-1993
			ZA 9204576 A	31-03-1993