

(19) **DANMARK**

(10) **DK/EP 2832992 T3**



Patent- og
Varemærkestyrelsen

(12) **Oversættelse af
europæisk patentskrift**

-
- (51) Int.Cl.: **F 03 D 80/60 (2016.01)**
- (45) Oversættelsen bekendtgjort den: **2018-01-22**
- (80) Dato for Den Europæiske Patentmyndigheds bekendtgørelse om meddelelse af patentet: **2017-12-13**
- (86) Europæisk ansøgning nr.: **13178485.2**
- (86) Europæisk indleveringsdag: **2013-07-30**
- (87) Den europæiske ansøgnings publiceringsdag: **2015-02-04**
- (84) Designerede stater: **AL AT BE BG CH CY CZ DE DK EE ES FI FR GB GR HR HU IE IS IT LI LT LU LV MC MK MT NL NO PL PT RO RS SE SI SK SM TR**
- (73) Patenthaver: **Siemens Aktiengesellschaft, Werner-von-Siemens-Straße 1, 80333 München, Tyskland**
- (72) Opfinder: **Soerensen, Peter Hesselund, Clemens 10, 8740 Brædstrup, Danmark**
- (74) Fuldmægtig i Danmark: **Zacco Denmark A/S, Arne Jacobsens Allé 15, 2300 København S, Danmark**
- (54) Benævnelse: **Vindmølle omfattende et kølesystem**
- (56) Fremdragne publikationer:
EP-A2- 2 302 214
WO-A1-2010/069954
CN-U- 201 908 789
GR-B- 1 005 990
US-A1- 2011 133 483

DESCRIPTION

[0001] This invention discloses an arrangement and a method to cool the air in a nacelle of a wind turbine.

[0002] A wind turbine comprises one or more rotor blades that are connected to a hub. The hub is connected to the nacelle. The nacelle is rotatable arranged on top of a tower.

[0003] The wind interacts with the rotor blades and rotates the hub. The rotation of the hub is transferred to an electric generator to generate electricity.

[0004] In addition, the electric power is converted to the voltage and frequency needed to feed the energy into the grid.

[0005] Electrical and mechanical components like the generator, optionally a gear, electric cabinets for the converter, or the transformer are often arranged in the nacelle of the wind turbine.

[0006] The electrical and mechanical components produce waste heat. To avoid high temperatures that might damage the components in the nacelle, the heat needs to be removed from the nacelle.

[0007] It is known to cool the nacelle and the components in the nacelle by guiding ambient air, from outside of the wind turbine, through the nacelle.

[0008] This shows the disadvantage that dust, humidity, sand or - in the case of an off-shore wind turbine or a wind turbine close to the sea - salt enters the nacelle together with the ambient air.

[0009] It is also known to cool electrical equipment in the nacelle with a closed cooling circuit.

[0010] WO 01/06121 A1 describes a cooling system for a wind energy facility that has a fully or at least partially closed cooling circuit, whereby the heat to be dissipated from the cooling circuit is evacuated by means of the tower or the nacelle of the wind energy facility.

[0011] WO 2010/069954 A1 discloses a wind turbine comprising a tower with an interior enclosed by a tower wall which forms a heat exchange surface in an air cooling circuit wherein the tower interior forms a channel for guiding hot air along a flow path, wherein one or more air flow deflectors are arranged within the flow path for guiding the flow towards the tower wall.

[0012] CN 201908789 U discloses another example of a wind turbine where the air from the nacelle is guided through the tower.

[0013] This solution shows the disadvantage, that the nacelle is arranged rotatable on top of the tower and that the cooling fluid needs to be transferred from the nacelle to the tower through a rotatable connection.

[0014] It is the aim of the invention to provide a cooling system for the equipment in the nacelle of the wind turbine with an easy transfer of the cooling fluid from the nacelle to the tower.

[0015] The aim is reached by the subject matter according to the independent claims. Preferred embodiments of the invention are described in the dependent claims.

[0016] Disclosed is a wind turbine cooling system, whereby a wind turbine comprises a nacelle and a tower, and the nacelle is rotatable arranged on top of the tower. A component is arranged in the nacelle, and the component emits excess heat.

[0017] A first cooling system is coupled with the component in a way to cool the component in the nacelle.

[0018] The tower comprises a chamber that is arranged in the upper part of the tower directly below and in contact with the nacelle. The roof of the chamber is the bottom part of the nacelle and the roof of the chamber is rotatable together with the nacelle in respect to the tower.

[0019] The first cooling system is connected to the chamber through the roof of the chamber, so that the heat from the first cooling system is transferred to the air in the chamber. The chamber is cooled by a second cooling system. The chamber comprises a floor and a second cooling system comprises a connection between the chamber and the tower through the floor.

[0020] The connection is used to guide the warm air from the chamber into the tower so that the warm air flows along the wall of the tower and is cooled by the tower wall, so that the tower is used as a heat sink. The transportation of heat from the first cooling system to the tower is independent from the rotation or orientation of the nacelle in respect to the tower.

[0021] The nacelle is arranged rotatable on top of the tower. This rotation is known as the yaw movement of the nacelle. All cables and pipes connecting the nacelle to components in the tower need to be designed in a way to perform the yaw rotation of the nacelle of a wind turbine.

[0022] A component that emits excess heat is arranged in the nacelle. A component that emits excess heat can be at a generator of the wind turbine, a transformer, an electrical cabinet or a converter. To remove the excess heat, the heat is transferred into the tower and the tower is used as a heat sink. Therefore, a first cooling system is connected to the component.

[0023] The first cooling system may just force air as a cooling medium through the nacelle,

the generator, the base-frame, or the shaft to cool a component present there. The first cooling system may also comprise tubes that guide a cooling fluid to the component to be cooled.

[0024] The tower comprises a chamber that is arranged in the upper part of the tower directly below and in direct contact with the nacelle. The floor of the chamber is a platform in the tower, in general the yaw platform. The wall of the chamber can be identical with the wall of the tower.

[0025] The roof of the chamber is build by the bottom part of the nacelle. Thus, the roof of the chamber rotates together with the nacelle, whereby the wall and the floor of the chamber are a part of the tower and do not rotate in respect to the tower.

[0026] The first cooling system is connected to the component in the nacelle to remove the heat from the component. The first cooling system transfers the heat from the component through the roof of the chamber into the chamber. Thus, the air in the chamber is heated up by the first cooling system.

[0027] The air in the chamber is cooled by a second cooling system that forces the air of the chamber down into the tower. The air in the tower flows along the tower and so also along the tower wall and transfers the thermal energy to the tower wall. The tower wall is then cooled by the wind or the ambient air around the tower.

[0028] The second cooling system comprises a connection between the chamber and the interior of the tower through the floor of the chamber. Thus, the heat of a component in the nacelle is transferred from the nacelle into the chamber and from the chamber into the tower.

[0029] The chamber is cooled by the second cooling system independently from the rotation or the orientation of the nacelle.

[0030] The first cooling system is connected to the component and to the roof of the chamber and rotates together with the roof of the chamber and the nacelle. Thus, the cooling of the chamber by the second cooling system can be performed independently from the rotation of the nacelle in respect to the tower.

[0031] Thus, the heat from the component can be transferred from the nacelle into the tower without the need of a pipe that performs the yaw movement of the nacelle. Thus, no rotatable connection of pipes for a cooling system is needed.

[0032] A rotatable connection in a pipe is normally subject to wear and tear in a wind turbine. A subject of wear and tear in the wind turbine needs a service and exchange on a regular basis.

[0033] No rotatable connection is needed to transfer the heat from the nacelle to the tower. Thus, the time and the money for service and the replacement of a rotatable connection are

saved. Thus, the costs of the operation of the wind turbine are lowered and thus the costs of energy produced are reduced.

[0034] The tower of a wind turbine comprises a yaw platform the separates the upper part of the tower from the rest of the tower. The yaw platform is covered by the bottom part of the nacelle. The room between the yaw platform and the nacelle forms a chamber. This chamber can be used as the chamber to transfer the heat from the nacelle to the tower.

[0035] The chamber comprises a floor. A first opening to allow air from the chamber to flow into the tower and a second opening to allow cool air from the tower to flow into the chamber are arranged in the floor of the chamber.

[0036] Thus, the air from the chamber can be transferred into the interior of the tower and the air from the interior of the tower can be transferred into the chamber. Thus, the air from the chamber can flow into the tower and can there transfer the thermal energy to the tower wall. Thus, the tower can be used as a heat sink.

[0037] An air duct is connected to the first opening to guide the warm air from the chamber down into the tower, so that the air flows along the tower wall on the way up towards the chamber and cools at a tower wall.

[0038] Thus, the warm air is guided down into the tower through the air duct. At the end of the air duct, the warm air exits the air duct. From there, the warm air flows upward inside the tower. The air flows along the tower wall and transfers its thermal energy to the tower wall.

[0039] By using an air duct which guides the air down into the tower, the length of the way of the air along the tower wall can be increased. Thus, the efficiency of the cooling of the air can be increased. Thus, more thermal energy can be transferred to the tower wall. Thus, the cooling is optimized.

[0040] An air duct is connected to the second opening so that the warm air flows through the first opening into the tower, flows down along the power wall, and cools at the tower wall. The cool air in the tower is guided into the chamber through the air duct and a second opening.

[0041] The warm air from the chamber flows through the first opening into the interior of the tower. In the interior of the tower the air flowing along the tower wall transfers thermal energy to the tower wall and cools. A volume of cool air along the tower wall starts flowing downward inside the tower. Thus the cool air collects in the lower parts of the tower.

[0042] The cool air from the lower parts of the tower is guided upwards through an air duct and the opening and the floor of the chamber into the chamber. Thus, cool air from the lower parts of the tower is transferred into the chamber by the air duct.

[0043] A ventilator is arranged at one of the openings so that the air is moved through the

tower. The exchange of air between the chamber and the tower can be increased by the use of a ventilator. The ventilator can be used to force air down into the tower or to suck air from the tower up into the chamber. Thus, the cooling effect of the tower used as a heat sink is increased.

[0044] The air duct is a pipe. The air duct is built as a pipe with a stiff outer wall. The stiff outer wall of a pipe provides a constant diameter of the pipe. Thus, the form of the pipe is not changed by the air flowing through the pipe and aerodynamic effects. Thus, the amount of air moving through the pipe is constant.

[0045] The pipe is more than 20 m long. Thus, the pipe is built to reach through at least one platform level in the tower. Thus, the way of the air inside the tower is prolonged. Thus, the cooling effect is increased.

[0046] The first cooling system comprises a heat exchanger that is arranged in the chamber to transfer the heat from the first cooling system to the air in the chamber.

[0047] The first cooling system transfers heat from the component through the nacelle into the chamber. Inside the chamber a heat exchanger is arranged at the roof of the chamber. Thus, the heat exchanger rotates together with the roof of the chamber and the nacelle of the wind turbine. Thus, the transfer of the heat from the first cooling system into the chamber is independent from the rotation of the nacelle.

[0048] By the use of a heat exchanger, the first cooling system is built as a cooling system with a closed cooling circuit. In the closed cooling circuit, air, water or oil can be used as a cooling medium.

[0049] The first cooling system transfers the heat from the component through the nacelle to the heat exchanger in a chamber. The heat exchanger rotates together with the nacelle. Thus, no rotatable connection is needed to transfer the cooling medium from the first cooling system to the heat exchanger.

[0050] A ventilator is arranged at the heat exchanger to transfer the heat from the first cooling system to the air in the chamber.

[0051] A ventilator is arranged at a heat exchanger to force the air in the chamber through or along the heat exchanger. Thus, the heat from the heat exchanger is transferred to the air in the chamber. By the use of a ventilator, a bigger amount of air is forced through or along the heat exchanger. Thus, the efficiency of the cooling system is increased.

[0052] Air is used as a cooling medium in the first cooling system. The air used as a cooling medium in the first cooling system can directly be exchanged with the air in the chamber. Thus, no heat exchanger is required. By the use of air as a cooling medium, no leakage problems can occur.

[0053] The first cooling system is connected to the chamber in a way that warm air from the first cooling system flows into the chamber through an opening in the roof of the chamber. And air from the chamber flows into the first cooling system of the nacelle through an opening in the roof of the chamber.

[0054] Thus, the air used as a cooling medium in the first cooling system is directly exchanged with the air in the chamber. Thus, no heat exchanger is required. Thus, the heat transfer between the first cooling system and the chamber is optimized.

[0055] The first cooling system comprises a ventilator so that air from the chamber is moved through the first cooling system. Thus, the exchange of air between the chamber and the first cooling system is increased. Thus, the cooling efficiency is increased.

[0056] The bottom of the chamber is the yaw platform of the tower. A tower of a wind turbine comprises a platform in the upper part of the tower that provides access to the yaw bearing for maintenance purpose. This yaw platform can be used as the bottom of the chamber of the cooling system. Thus, no additional platform has to be provided as a floor of the chamber.

[0057] A method is disclosed to cool a component in the nacelle of a wind turbine. A wind turbine comprises a nacelle and a tower, and the nacelle is rotatable arranged on top of the tower. A component is arranged in the nacelle and the component emits excess heat. A first cooling system is coupled with the component in a way to cool the component in the nacelle. The tower comprises a chamber that is arranged in the upper part of the tower directly below and in contact with the nacelle. The roof of the chamber is the bottom part of the nacelle and that the roof of the chamber is rotatable together with the nacelle in respect to the tower.

[0058] The method comprises the step of transferring the heat from the component in the nacelle into the chamber by a first cooling system. The method comprises that further step of cooling the air and the chamber by forcing the air into the tower where the air flows along the tower wall and transfers the heat to the tower wall.

[0059] The invention is shown in more detail by the help of figures. The figures show a preferred configuration and do not limit the scope of the invention.

FIG 1

shows a wind turbine with a cooling system,

FIG 2

shows a second embodiment of the cooling system,

FIG 3

shows a third embodiment of the cooling system.

[0060] FIG 1 shows a wind turbine with a cooling system. FIG 1 shows a wind turbine 1 with a

cooling system. The wind turbine comprises a nacelle 2 and a tower 3, whereby the nacelle 2 is arranged rotatable on top of the tower 3.

[0061] A component 4 is arranged in the nacelle 2, whereby the component 4 produces excess heat and needs to be cooled. The component 4 can either be the generator of the wind turbine or an electric cabinet, like a converter or a transformer.

[0062] The tower 3 comprises a chamber 6. The chamber 6 is arranged in the other part of the tower 3. The chamber 6 is in direct contact to the nacelle 2, whereby the roof 7 of the chamber 6 is the lower part of the nacelle 2. Thus, the roof 7 of the chamber 6 rotates together with the nacelle 2.

[0063] The floor 18 of the chamber 6 is a platform in the tower 3, preferably the yaw platform of the wind turbine 1.

[0064] A first cooling system 5 is connected to the component 4 in a way that it transfers the heat from the component 4 into the chamber 6.

[0065] The first cooling system 5 uses air as a cooling medium. The air flows through an opening 16 from the chamber 6 to the component 4. The air picks up the heat of the component and flows through a pipe and an opening 17 back into the chamber 6.

[0066] Thus, the heat of the component 4 is transferred to the chamber 6. A ventilator 15 is arranged at the opening 17 to move the air from the component 4 into the chamber 6.

[0067] The heat in the chamber 6 is removed by a second cooling system 8. The second cooling system 8 comprises an opening 9 in the floor 18 of the chamber 6.

[0068] A pipe 11 is connected as an air-duct to the opening 9. A ventilator 12 is arranged within the air duct. A ventilator 12 moves the warm air from the chamber 6 through the duct 11 into the tower 3. Preferably, the air duct 11 is more than 20 m long.

[0069] The warm air that exits the air duct 11 at a lower level in the tower 3, flows upwards inside the tower 3 and is cooled as it flows along the wall of the tower 3. The air enters the chamber 6 through an opening 10 in the floor 18 of the chamber 6.

[0070] Thus, the heat of the component 4 is transferred through the chamber 6 into the tower 3 and the tower 3 is used as a heat sink. In the tower 3, the heat of the warm air is transferred to the tower wall and the tower wall is cooled by the wind and the ambient air.

[0071] FIG 2 shows a second embodiment of the cooling system. FIG 2 shows a second embodiment of the cooling system in the wind turbine 1. The wind turbine 1 comprises a nacelle 2 that is arranged rotatable on top of a tower 3.

[0072] A component 4 is arranged in the nacelle 2. The component 4 can be a generator, a transformer, a converter or an electrical cabinet inside the nacelle 2. The component 4 produces excess heat that need to be cooled.

[0073] The first cooling system 5 is installed to cool the component 4. The tower 3 comprises a chamber 6, whereby the roof of the chamber is the lower part of the nacelle 2. Thus, the roof of the chamber 6 rotates together with the nacelle 2.

[0074] The floor 18 of the chamber 6 is a platform in the tower in general the yaw platform. The wall of the chamber 6 is built by the wall of the tower 3.

[0075] Air from the chamber is flowing through an opening 6 and the roof 7 of the chamber to the component 4 in the nacelle 2. The air removes the heat from the component 4 and flows through a tube and the opening 15 back into the chamber 6. A ventilator 17 is arranged at the opening 15 to move the air through the first cooling system.

[0076] The hot air in the chamber 6 is moved by a ventilator 12 through an opening 9 in the floor 18 of the chamber 6. The ventilator 12 forces the air from the chamber 6 into the lower part of the tower 3. On the way down into the tower, the air flows along the tower wall and transfers its thermal energy to the tower wall.

[0077] Further down in the tower 3, the air flows through a pipe 11, that is used as an air-duct, back through an opening 10 in the floor 18 of the chamber 6 into the chamber.

[0078] The ventilator 12, the pipe 11 and the openings 9 and 10 form a second cooling system 8. The second cooling system 8 transfers the warm air from the chamber 6 into the tower 3. The tower 3 is used as a heat sink for the warm air of the chamber 6. Thus, the air in the chamber 6 gets cooled by the second cooling system 8.

[0079] FIG 3 shows a third embodiment of the cooling system. FIG 3 shows a third embodiment of the cooling system of a wind turbine 1. The wind turbine 1 comprises a nacelle 2 and a tower 3, whereby the nacelle 2 is arranged rotatable on top of the tower 3.

[0080] A component 4 is arranged in the nacelle 2. The component 4 produces excess heat and needs to be cooled. A first cooling system 5 is connected to the component 4 to transfer the heat from the component 4 into the tower 3.

[0081] The tower 3 comprises a chamber 6 in the upper part of the tower, whereby the roof 7 of the chamber 6 is the lower part of the nacelle 2. Thus, the roof 7 of the chamber 6 rotates together with the nacelle 2. The wall of the chambers 6 is built by the wall of the tower 3.

[0082] The floor 18 of the chamber 6 is a platform in the tower, in general the yaw platform.

[0083] The first cooling system 5 comprises a heat exchanger 13 that transfers the heat from

the component 4 into the chamber 6 in the tower 3.

[0084] A ventilator 14 is arranged to move the air along the heat exchanger 13 to transfer the heat from the first cooling system 5 to the air in the chamber 6. The air in the chamber 6 is cooled by a second cooling system 8.

[0085] The second cooling system 8 comprises an opening 9, a ventilator 12, a pipe 11, the tower 3, and an opening 10. The warm air of the chamber 6 is flowing through the opening 9 and through the pipe 11. A ventilator 12 is arranged within the pipe 11 to move the air from the chamber 6 through the pipe 11 into the tower 3.

[0086] The air that exits the pipe 11 flows upward inside the tower 3 and transfers its thermal energy to the tower wall. The tower wall is then cooled by the wind and the ambient air outside of the tower. Thus, the tower 3 is used as a heat sink in the second cooling system 8. The cool air from the tower moves through the opening 10 back into the chamber 6.

[0087] The first cooling system 5 is built as a closed cooling circuit. As a cooling fluid in the first cooling system 5 air, water or oil can be used.

[0088] Although the present invention has been described in detail with reference to the preferred embodiment, it is to be understood that the present invention is not limited by the disclosed examples, and that numerous additional modifications and variations could be made thereto by a person skilled in the art without departing from the scope of the invention.

[0089] It should be noted that the use of "a" or "an" throughout this application does not exclude a plurality, and "comprising" does not exclude other steps or elements. It should also be noted that reference signs in the claims should not be construed as limiting the scope of the claims.

REFERENCES CITED IN THE DESCRIPTION

This list of references cited by the applicant is for the reader's convenience only. It does not form part of the European patent document. Even though great care has been taken in compiling the references, errors or omissions cannot be excluded and the EPO disclaims all liability in this regard.

Patent documents cited in the description

- [WO0106121A1 \[0010\]](#)
- [WO2010069954A1 \[0011\]](#)

- CN201908789U [0012]

Patentkrav

1. Vindmølle, som omfatter et kølesystem,

5 - hvor en vindmølle (1) omfatter en nacelle (2) og et tårn (3), og nacellen (2) er roterbart anbragt øverst på tårnet (3),

- hvor en komponent (4) er anbragt i nacellen (2), og komponenten (4) afgiver overskudsvarme, og et første kølesystem (5) er koblet med komponenten (4) på en sådan måde, at det køler komponenten (4) i nacellen (2),

10 - hvor tårnet (3) omfatter et kammer (6), som er anbragt i den øvre del af tårnet (3), direkte under og i kontakt med nacellen (2),

- hvor taget (7) af kammeret (6) er den nedre del af nacellen (2), og taget (7) af kammeret (6) er roterbart sammen med nacellen (2) i forhold til tårnet (3),

kendetegnet ved, at det første kølesystem (5) er forbundet med kammeret (6) gennem taget (7) af kammeret (6), således at varmen fra det første kølesystem (5) overføres til luften i kammeret (6),

15 - hvor kammeret (6) køles af et andet kølesystem (8),

- hvor kammeret (6) omfatter et gulv, og det andet kølesystem (8) omfatter en forbindelse (9, 10) mellem kammeret (6) og tårnet (3) gennem gulvet, hvor en første åbning (9) til at gøre det muligt for luft fra kammeret (6) at strømme ind i tårnet (3) og en anden åbning (10) til at gøre det muligt for køleluft fra tårnet (3) at strømme ind i kammeret (6) er anbragt i kammerets gulv for at lede varmluften fra kammeret (6) ind i tårnet (3), således at varmluften strømmer langs tårnets væg og køles af tårnvægen, således at tårnet (3) anvendes som et kølelegeme,

25 - således at transporteringen af varme fra det første kølesystem til tårnet er uafhængig af rotationen eller orienteringen af nacellen (2) i forhold til tårnet (3).

30 **2.** Vindmølle ifølge krav 1, hvor en luftkanal (11) er forbundet med den første åbning (9) for at lede varmluften fra kammeret ned i tårnet (3), således at luften strømmer langs tårnvæggen på vej op mod kammeret og køles ved tårnvæggen.

35 **3.** Vindmølle ifølge krav 1, hvor en luftkanal (11) er forbundet med den anden åbning (10), således at varmluften strømmer gennem den første åbning (9)

ind i tårnet, strømmer ned langs tårnvæggen og køles ved tårnvæggen, og at køleluften i tårnet ledes ind i kammeret (6) gennem luftkanalen (11) og den anden åbning (10).

5 **4.** Vindmølle ifølge et af kravene 1 eller 2, hvor en ventilator (12) er anbragt ved en af åbningerne (9, 10), således at luften bevæges gennem tårnet (3).

5. Vindmølle ifølge et af kravene 1 til 3, hvor luftkanalen (11) er et rør.

10 **6.** Vindmølle ifølge krav 5, hvor røret er mere end 20 meter langt.

7. Vindmølle ifølge et af de foregående krav, hvor det første kølesystem (5) omfatter en varmeveksler (13), som er anbragt i kammeret (6), til overførsel af varmen fra det første kølesystem (5) til luften i kammeret (6).

15

8. Vindmølle ifølge krav 7, hvor der er anbragt en ventilator (14) ved varmeveksleren (13) til overførsel af varmen i det første kølesystem til luften i kammeret (6).

20

9. Vindmølle ifølge et af kravene 1 til 4, hvor der anvendes luft som et kølemedium i det første kølesystem (5).

10. Vindmølle ifølge krav 9, hvor det første kølesystem (5) er forbundet med kammeret (6) på en sådan måde, at varmluft fra det første kølesystem (5) strømmer ind i kammeret (6) gennem en åbning (15) i taget (7) af kammeret (6), og luft fra kammeret (6) strømmer ind i det første kølesystem (5) af nacellen (2) gennem en åbning (16) i taget (7) af kammeret (6).

25

11. Vindmølle ifølge et af kravene 9 eller 10, hvor det første kølesystem (5) omfatter en ventilator (17), således at luft fra kammeret (6) bevæges gennem det første kølesystem (5).

30

12. Vindmølle ifølge et af de foregående krav, hvor bunden af kammeret (6) er krøjningsplatformen (18) af tårnet (2).

35

13. Fremgangsmåde til køling af en komponent (4) i nacellen (2) af en vindmølle (1),

- hvor en vindmølle (1) omfatter en nacelle (2) og et tårn (3), og nacellen (2) er roterbart anbragt øverst på tårnet (3),

5 - hvor en komponent (4) er anbragt i nacellen (2), og komponenten (4) afgiver overskudsvarme, og et første kølesystem (5) er koblet med komponenten (4) på en sådan måde, at det køler komponenten (4) i nacellen (2),

10 - hvor tårnet (3) omfatter et kammer (6), der er anbragt i den øvre del af tårnet (3), direkte under og i kontakt med nacellen (2), således at taget (7) af kammeret (6) er den nedre del af nacellen (2), og at taget (7) af kammeret (6) er roterbart sammen med nacellen (2) i forhold til tårnet (3),

omfattende trinnene med

- at føre varmen fra komponenten (4) i nacellen (2) ind i kammeret (6) ved et første kølesystem (5),

15 - at køle luften i kammeret (6) ved at tvinge luften ind i tårnet (3), hvor en første åbning (9) til at gøre det muligt for luft fra kammeret (6) at strømme ind i tårnet (3) og en anden åbning (10) til at gøre det muligt for køleluft fra tårnet (3) at strømme ind i kammeret (6) er anbragt i kammerets gulv, hvor luften strømmer langs tårnvæggen og overfører varmen til tårnvæggen.

20

DRAWINGS

FIG 1

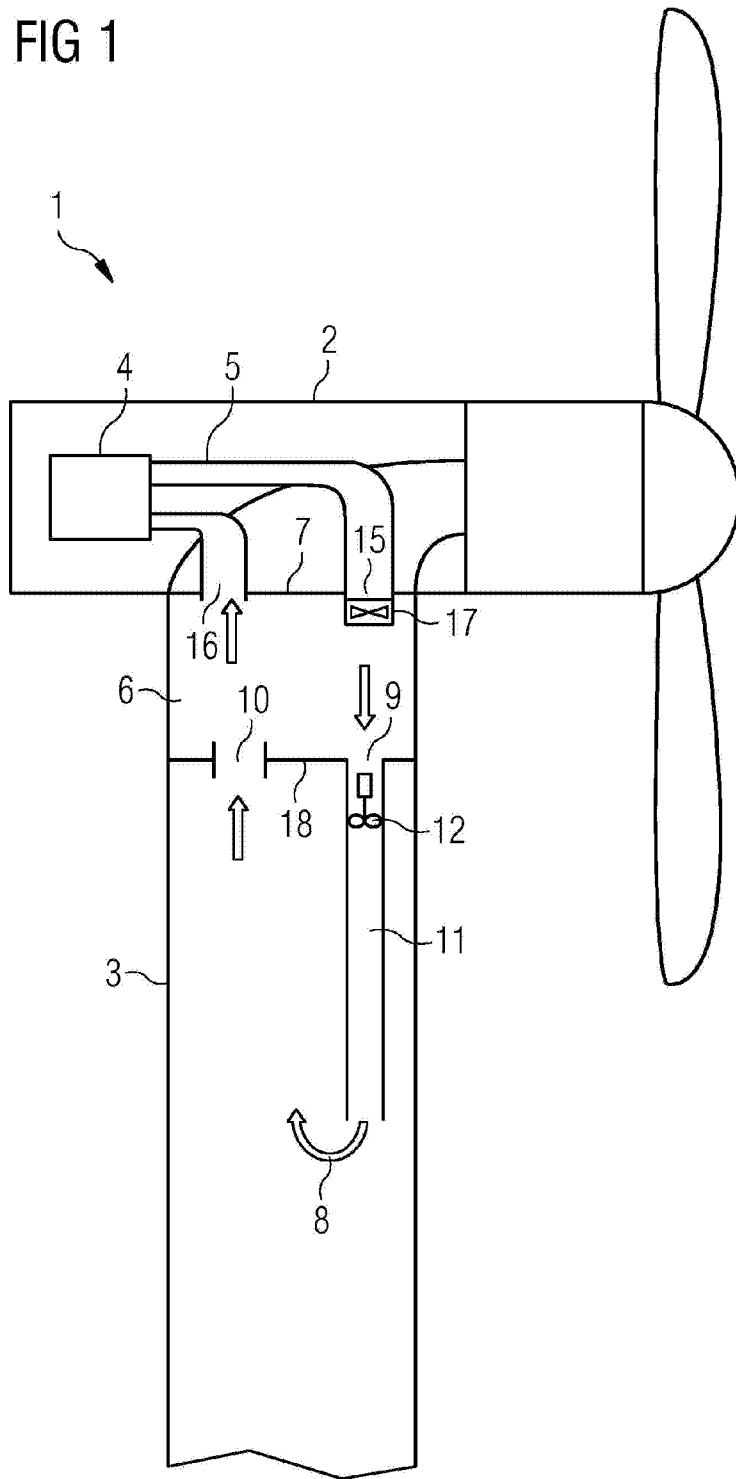

FIG 3

