

March 14, 1933.

M. J. MILMOE

1,901,832

STARTER MECHANISM FOR FEEDING BLANKS OR THE LIKE

Filed March 10, 1930

2 Sheets-Sheet 1

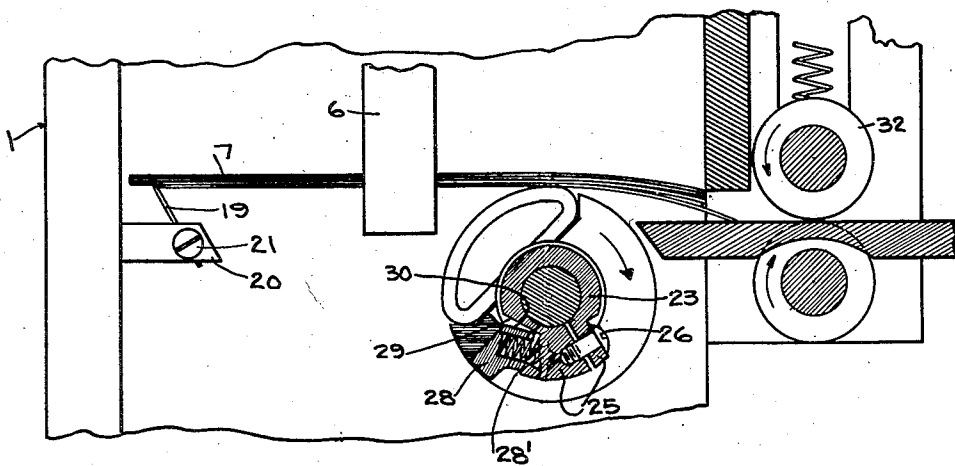
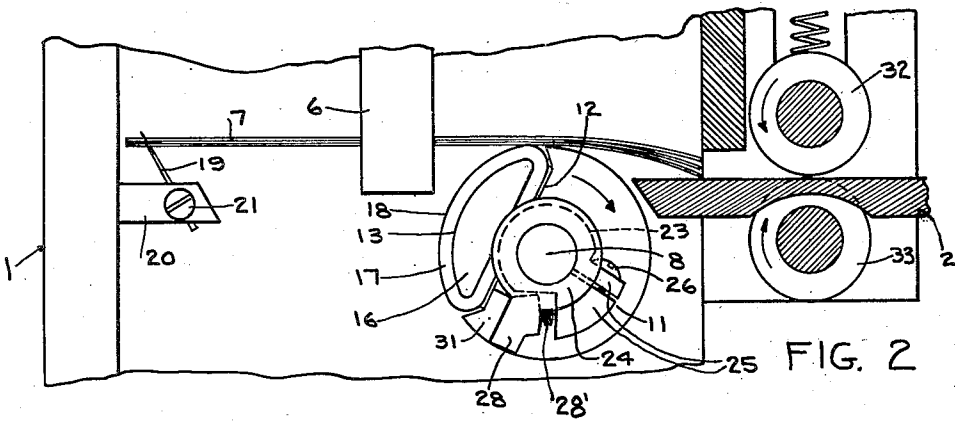
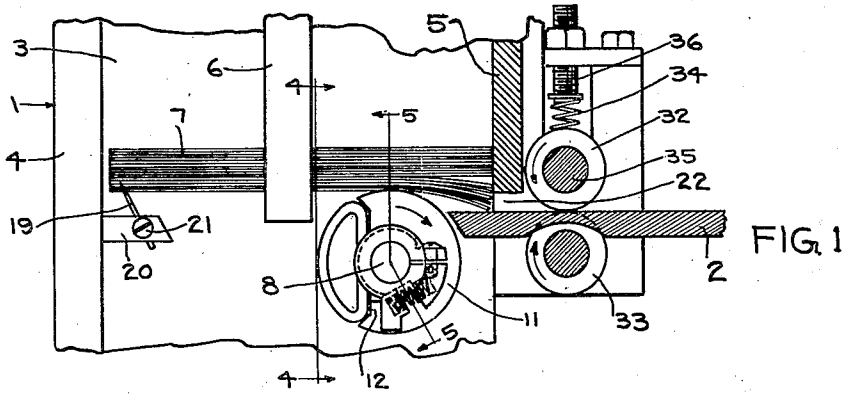

FIG. 3

INVENTOR:
Michael J. Milmoel,
BY Chas. M. Tison,
ATTORNEY.

March 14, 1933.

M. J. MILMOE

1,901,832

STARTER MECHANISM FOR FEEDING BLANKS OR THE LIKE

Filed March 10, 1930

2 Sheets-Sheet 2

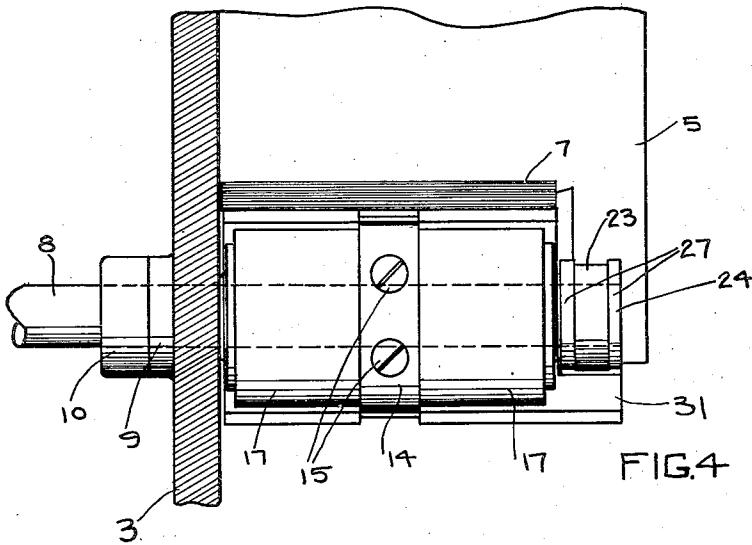

FIG. 4

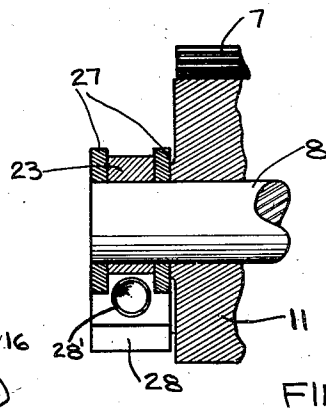

FIG. 5

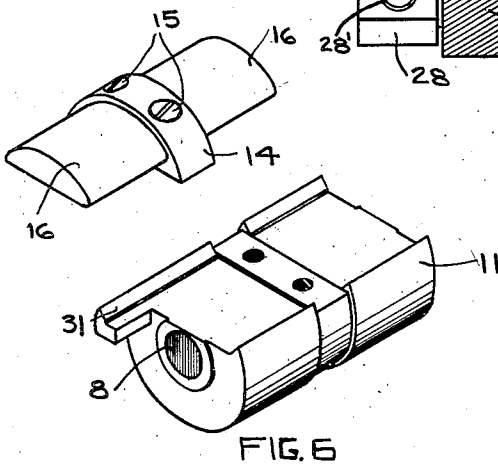

FIG. 6

INVENTOR:
Michael J. Milmoë,
BY Chas. M. Nissen,
ATTORNEY

UNITED STATES PATENT OFFICE

MICHAEL J. MILMOE, OF CHICAGO, ILLINOIS, ASSIGNOR TO F. B. REDINGTON CO., OF CHICAGO, ILLINOIS, A CORPORATION OF ILLINOIS

STARTER MECHANISM FOR FEEDING BLANKS OR THE LIKE

Application filed March 10, 1930. Serial No. 434,616.

This invention relates to packaging machines and more particularly to that class of machines in which a wrapper in the form of a flat sheet of paper is fed out of a hopper or magazine into a position where the same is wrapped about the article. More specifically this invention pertains to the means for feeding one blank at a time out of the magazine.

One object of this invention is the provision of suitable feeding means for feeding the blanks out of the magazine without tearing the same.

Another object of this invention resides in providing a uniform amount of feed for each of the blanks as they are fed out of the magazine.

A still further object resides in providing a means for feeding the blanks out of the magazine which comprises a yielding means which insures that rolling friction instead of sliding friction is the force which moves the blanks out of the magazine. It is well known that rolling friction is a greater force than sliding friction, and therefore if the blanks are fed out of the machine by rolling friction instead of sliding friction, it is more certain that the blanks will be fed out of the magazine properly.

A more specific object of this invention resides in the provision of a two-part feeding mechanism, the parts being movable relatively to each other and one of the parts being driven at a constant speed.

A still further object of this invention resides in providing a friction feeding device in which the friction surface has its motion retarded as it strikes the blank which is to be fed from the magazine and as the blank is being fed out of the magazine this friction surface again increases its speed.

Other objects of this invention will appear as the description of this invention proceeds.

In the drawings—

Fig. 1 represents a side elevational view of a device embodying my invention, this device being shown partly in section for the sake of clearness;

Fig. 2 is a view similar to Fig. 1 but showing the parts in a slightly different position;

Fig. 3 is a view similar to Figs. 1 and 2,

but showing the parts in still another position and with additional parts in section for the sake of clearness;

Fig. 4 is a section taken along the line 4—4 of Fig. 1;

Fig. 5 is a section taken substantially along the line 5—5 of Fig. 1; and

Fig. 6 is a perspective view of the feed roller.

My invention is shown embodied in a device for feeding a series of blanks out of a magazine 1 onto a support 2, these blanks being delivered onto the support 2 one at a time. The magazine may be of any suitable construction, but the magazine illustrated comprises the side wall 3, rear wall 4 and front wall 5. The side of magazine opposite to the wall 3 is open and an agitating bar 6 which is movable horizontally and engages the edges of the blanks 7 within the magazine, insures that the blanks will be always fed downwardly towards the bottom of the magazine.

A shaft 8 extends through the wall 3 of the magazine and is rotatably supported by suitable bearings, one of which is shown in Fig. 4 at 9, a collar 10 being used to prevent endwise displacement of the shaft 8. I mount a cylindrical member 11 freely upon the shaft 8 so that the same may rotate about the shaft 8 except that I provide means which limits the amount of rotation of the member 11 about the shaft 8. This mechanism I will describe shortly.

The cylindrical member 11 has one side thereof recessed at 12 to receive a member designated generally as 13. This member has the central portion 14 thereof adapted to be secured by means of screws 15 to the cylindrical part 11, and this central part 14 carries oppositely disposed portions 16 which have an outer curved surface of lesser radius than radius of curvature of the outer surface of the member 11. The flat surfaces of the portion 16 (see particularly Figs. 1, 2 and 3) are spaced from the bottom of the recess 12. Friction elements 17 preferably formed of rubber are in the form of closed loops as best illustrated in Figs. 1, 2 and 3. These loops are placed over the portion 16 and the thick-

ness of the material which forms the loops is sufficiently great to give a radius of curvature to the outer surfaces of the friction members when they have been placed on the portion 5 16, which is greater than the radius of curvature of the cylindrical surface of the member 11 and this friction surface which I shall designate as 18 therefore will lie farther away from the axis of the shaft 8 than will the 10 outer surface of the cylindrical member 11.

A sharp needle like member 19 is secured in a bracket 20 by means of a screw 21 and this needle penetrates the lowermost ones of the blanks within the magazine and has a 15 tendency to prevent movement of the blanks out of the opening 22 which is formed by the space between the wall 5 and the support 2.

If we were to consider first that the member 11 were secured to the shaft 8 it will readily 20 be seen that when the friction surface 18 engages the lowermost one of the blanks in the magazine, there will be a tendency at least at first, for the friction surface to slide over the surface of the blank so that the blank is 25 not moved forward through the opening 22 or at least is not moved forward as quickly as may be desired nor as uniformly as is required for the correct operation thereof. This is due to the fact that when the friction surface 30 18 engages the blanks the same tends to slide thereover, and it is well known that sliding friction is not the greatest force which may be exerted between surfaces which roll on each other and yet are capable of sliding 35 movement relatively to each other. Therefore, if some means is provided for insuring that rolling friction instead of sliding friction causes the blanks to move out of the magazine, a result will be accomplished that 40 is far superior to a starting roller which is fixed on a rotating shaft such as the shaft 8.

My present invention relates to a machine for insuring that rolling friction instead of 45 sliding friction causes the blanks to be moved out through the opening 22 onto the support 2. This means comprises a pair of members 23 and 24, the former of which is provided with a pair of ears 25 through which the screw 26 extends. By tightening the 50 screw 26 the ears 25 are drawn together and in this manner a member 23 is securely clamped on the shaft 8 and is constrained to move therewith. The member 24 has two cylindrical portions 27 which lie on opposite 55 sides of the member 23, and these bearing portions are connected by the cross piece 28. The member 24 is free to rotate on the shaft 8 except as hereinafter provided. The cross piece 28 and one of the lugs 25 each have 60 recesses in opposed faces thereof for the reception of a spring 28' best illustrated in Fig. 3. This spring has a tendency to move the member 24 in a clockwise direction about the shaft 8 as viewed in Fig. 3, and this 65 movement is limited by a stop-shoulder 29 on

the member 23, this stop-shoulder engaging the flat side 30 of the cross-member 28. The cylindrical portion 11 carries an extension 31 which extends outwardly into the path of the cross-member 28 and is engaged thereby as 70 the shaft 8 rotates.

The outer surface of the member 11 is comparatively smooth so that as the blanks rest on this surface during the rotation of the shaft 8, there is very little tendency for the 75 blanks to be moved out of the magazine. However, the friction surface 18 has a higher coefficient of friction than the surface on the member 11 and tends to move the blanks out of the magazine when the friction 80 surface 18 engages the blanks. Let us assume that the parts are in the position shown in Fig. 1, with the blanks resting on the needle 19, and the surface of the cylindrical member 11. The needle will overcome all 85 of the frictional force exerted between the member 11 and the blanks 7 and the blanks will not move out of the magazine, however, as the shaft 8 continues to rotate in the direction of the arrow the friction surface 18 en- 90 gages the lower blank of the stack of blanks in the magazine and the friction between the friction surface 18 and the lowermost blank tends to retard the movement of the member 17 and also the friction surface 18 and due 95 to the spring 28' which is arranged between the members 23 and 24, the member 13 which carries the friction element is enabled to yield and have its motion retarded even though the shaft 8 and the member 11 con- 100 tinue to rotate at a constant speed. However, it will be understood that the friction is still maintained between the member 18 and the lowermost blank and tends always to move the blank out of the magazine. The 105 blank is started from its position of rest in a more or less gradual manner due to the yielding engagement between the friction surface and the blank and instead of the friction surface sliding over the blank the same 110 is soon rolling over the surface of the blank and this rolling continues during the entire movement of the blank out of the magazine and onto the support 2. In this manner a greater amount of friction is used to move the 115 blank out of the magazine than is the case where sliding friction is depended upon for moving the blanks out of the magazine.

My invention is particularly important for feeding the last of a series of blanks out of 120 the magazine for at that time the weight of the blanks has decreased a considerable extent, and therefore it is necessary to use the maximum available amount of friction in moving the blanks out of the magazine. 125 Since rolling friction and not sliding friction is the greater of the two, my device will work more efficiently than the devices which have been in use prior to my invention.

Another feature of my invention is that 130

the position of the friction surface relatively to the shaft 8 may be very quickly changed merely by loosening the screw 26 and moving the member 23 about the shaft the desired amount. In this manner the time at which the blank is fed out of the magazine may be regulated. This is a very desirable feature of my invention in view of the fact that the blanks must be fed from the magazine in a predetermined timed relation to the movements of the other parts of the mechanism which are not shown. In other words, a slight delay in feeding the blank out of the magazine is apt to result in a serious delay in the operation of the machine, and if the blank is fed out of the magazine too soon, the previous blank may not have cleared or the rest of the mechanism may not be ready to receive the blank and thus cause delay.

When the blanks are fed out of the magazine they pass between the rollers 32 and 33 which rotate in the direction shown by the arrows in Figs. 1, 2 and 3. The spring 34 presses against the shaft 35 which supports the roller 32 and urges the roller 32 towards the roller 33. An adjusting screw 36 regulates the tension on the spring 34. These rollers receive the blank therebetween after the blank moves through the opening 22 and move the blank clear of the magazine, it being understood that the starter roller having the friction surface 18 is used only for the purpose of starting the blanks out of the magazine.

Obviously those skilled in the art to which this invention pertains may make various changes therein and construct other modifications thereof without departing from the spirit of this invention or the scope of the appended claims.

Having thus fully described my invention, what I desire to secure by Letters Patent of the United States is:

1. Feeding mechanism comprising a magazine for receiving blanks, a needle upon which a portion of the blanks rest, a starting roll, a shaft upon which said starting roll is mounted, yielding connection between said shaft and starting roll for driving the latter, and a friction surface on a portion only of the cylindrical surface of said starting roll, said connection between said shaft and starting roll being such as to permit said roll to be retarded when said portion which has a high coefficient of friction engages one of said blanks.

2. In a blank-feeding apparatus, the combination of a continuously moving member adapted to travel in a fixed path relative to a stack of blanks, a frictional feed element actuated by said member, means associated with said moving member for continuously moving said feed element in a single and fixed path of travel past said stack of blanks, said means including devices for permitting

the speed of travel of said feed element to be retarded sufficiently to frictionally grip a blank and feed it forwardly when said feed element moves into engagement with said blank.

3. In a blank-feeding apparatus, the combination of a continuously moving member having a surface adapted to travel in slipping contact with a blank contained in a stack of blanks, a frictional feed element of a greater coefficient of friction and having its surface projecting beyond and immovable relative to the first mentioned surface and adapted likewise to contact said stack of blanks, and means for yieldingly permitting the speed of travel of said frictional feed element to be retarded without stopping it to permit it to feed blanks in said stack forwardly.

4. In a blank-feeding apparatus, a continuously rotatable driving member, means having an interrupted frictional blank-feeding surface, said means being mounted on said driving member and continuously rotating with said driving member in a circular path of constant radius from the axis of rotation of said shaft, and means whereby said feeding surface is adapted resiliently to yield angularly with respect to its axis of rotation when the said surface engages the blank to be fed whereby the speed of travel of said surface is retarded to initiate the feeding action.

5. In a blank-feeding apparatus, a rotatable shaft, means having an interrupted frictional blank-feeding surface, said means being mounted on said shaft and rotating with said shaft in a circular path of fixed radius relative to the axis of rotation of said shaft, and means whereby said feeding surface is adapted to be retarded angularly with respect to its axis of rotation whereby the speed of travel of said surface is retarded to initiate the feeding action.

6. In a blank-feeding apparatus, driving means, a feed roll driven by said means and having means forming a frictional feed surface rigid with said roll, and means automatically actuated by the contact of said frictional feed surface with the blank to be fed adapted to yield to thereby permit retarding the speed of travel of said surface sufficiently to give said surface a rolling contact with said blank to feed the blank.

7. In a blank-feeding apparatus, driving means, a feed roll driven by said means and having means forming a frictional feed surface rigid therewith and projecting beyond the periphery of said roll, and means automatically actuated by contact of said outwardly projecting portion with the blank to be fed, for permitting the speed of travel of said surface to be decreased whereby to give said surface a rolling contact with said blank to feed the blank.

8. In a blank-feeding apparatus, driving means, a feed roll driven by said means and having means forming a frictional feed surface rigid therewith, and means automatically actuated by contact of said frictional feed surface with the blank to be fed for permitting the lessening of the speed of travel of said surface to give said surface a rolling contact with said blank to feed the blank.
9. In a blank-feeding apparatus, driving means, a roll rotated thereby and having a peripheral portion adapted to rotate in slipping contact with a blank, said roll having a peripheral portion of greater coefficient of friction than said first mentioned peripheral portion and rigid with said first mentioned peripheral portion, and means for permitting the lessening of the speed of travel of said portion of greater coefficient of friction to permit it to grip the work and feed the blank forwardly.
10. In a blank-feeding apparatus the combination of driving means, a roll rotatably driven thereby having a periphery rotating in slipping contact with a blank, said roll having another peripheral portion of greater coefficient of friction rigid with said first mentioned portion and projecting beyond the periphery thereof for contact with the blank, and means for automatically lessening the speed of travel of said second mentioned portion sufficiently to permit it to grip the blank and feed it forwardly.
11. A rotatable feed roll having means forming a peripheral feed surface of greater coefficient of friction than the remaining peripheral surface of the roll and immovable relatively thereto, and a yielding driving means for said roll.
12. A rotatable feed roll having a blank-contacting peripheral portion and means forming a feed surface of greater coefficient of friction and projecting beyond the periphery of said blank-contacting portion and immovable relative thereto, and a yielding driving means for said roll.
13. In a blank-feeding mechanism, the combination of a continuously rotating driving member, a frictional feed surface adapted to be rotated by said driving means for frictionally contacting a blank to feed it forward, and means for permitting said feeding surface to shift angularly with respect to said driving means, and means for adjusting the position of said feeding surface relative to the axis of rotation of the driving means whereby to control the time of feed of said blank.
14. In a blank-feeding apparatus, the combination of a stack of blanks, a movable element having a feed surface adapted to engage a blank in said stack, means for continuously moving said feed element, means for sufficiently retarding the speed of travel of said feed surface without stopping it to permit said feed surface to initiate the feeding of the blank, and means for adjusting the position of said feed surface relative to said movable element for controlling the time of contact of said feed surface with the blank.
15. A blank-feeding device comprising a continuously rotating shaft, a feed roller loosely mounted on said shaft, said feed roller having a sector-shaped peripheral portion rigidly and detachably mounted thereon, the surface of said portion having a greater coefficient of friction than the feed roll and projecting beyond the peripheral plane of said roll, said feed roll having a laterally projecting abutment, means forming an abutment mounted on said shaft for angular adjustment relative to said shaft, and means interposed between said abutment and the lateral projection on said roll forming a yielding driving connection between said abutment on said shaft and the abutment on said roll.
16. In a blank feeding apparatus, a roll having a feed surface immovable relative to said roll, driving means, means cooperating with said roll and driving means for rotating said roll, said cooperating means being yieldable to permit the retarding of the rotation of said roll without stopping the rotation of said roll to initiate the feeding of said blank.
17. Feeding means for feeding blanks and the like comprising a cylindrical member rotatable upon a fixed axis and having a flattened portion extending parallel to its axis of rotation below said cylindrical surface, a second member adapted to be secured to said flattened surface, and friction elements arranged about said second member and adapted to project beyond the cylindrical surface of said first member when said second member is secured to said first member.
18. In a blank-feeding apparatus, the combination of a continuously moving member having a surface adapted to travel in slipping contact with a blank contained in a stack of blanks, a frictional feed element of greater coefficient of friction having the surface thereof immovable relative to the first mentioned surface and adapted likewise to contact said stack of blanks at certain intervals, and means for yieldingly permitting the speed of travel of said frictional feed element to be retarded without stopping it to permit the same to feed blanks in said stack forwardly.
- In testimony whereof I have signed my name to this specification on this 8th day of March, A. D. 1930.

MICHAEL J. MILMOE.