



(51) International Patent Classification:

A61B 18/14 (2006.01) A61B 17/28 (2006.01)  
A61B 18/00 (2006.01) A61B 17/29 (2006.01)

(21) International Application Number:

PCT/US2019/028943

(22) International Filing Date:

24 April 2019 (24.04.2019)

(25) Filing Language:

English

(26) Publication Language:

English

(30) Priority Data:

15/970,404 03 May 2018 (03.05.2018) US

(71) Applicant: FARAPULSE, INC. [US/US]; 3715 Haven Avenue, Suite 110, Menlo Park, California 94025 (US).

(72) Inventors: VISWANATHAN, Raju; c/o Farapulse, Inc., 3715 Haven Avenue, Suite 110, Menlo Park, California 94025 (US). LONG, Gary L.; c/o Farapulse, Inc., 3715 Haven Avenue, Suite 110, Menlo Park, California 94025 (US).

(74) Agent: WU, Robert H. et al.; Cooley LLP, 1299 Pennsylvania Avenue, NW, Suite 700, Washington, District of Columbia 20004-2400 (US).

(81) Designated States (unless otherwise indicated, for every kind of national protection available): AE, AG, AL, AM, AO, AT, AU, AZ, BA, BB, BG, BH, BN, BR, BW, BY, BZ, CA, CH, CL, CN, CO, CR, CU, CZ, DE, DJ, DK, DM, DO, DZ, EC, EE, EG, ES, FI, GB, GD, GE, GH, GM, GT, HN, HR, HU, ID, IL, IN, IR, IS, JO, JP, KE, KG, KH, KN, KP, KR, KW, KZ, LA, LC, LK, LR, LS, LU, LY, MA, MD, ME, MG, MK, MN, MW, MX, MY, MZ, NA, NG, NI, NO, NZ, OM, PA, PE, PG, PH, PL, PT, QA, RO, RS, RU, RW, SA, SC, SD, SE, SG, SK, SL, SM, ST, SV, SY, TH, TJ, TM, TN, TR, TT, TZ, UA, UG, US, UZ, VC, VN, ZA, ZM, ZW.

(84) Designated States (unless otherwise indicated, for every kind of regional protection available): ARIPO (BW, GH, GM, KE, LR, LS, MW, MZ, NA, RW, SD, SL, ST, SZ, TZ, UG, ZM, ZW), Eurasian (AM, AZ, BY, KG, KZ, RU, TJ, TM), European (AL, AT, BE, BG, CH, CY, CZ, DE, DK, EE, ES, FI, FR, GB, GR, HR, HU, IE, IS, IT, LT, LU, LV, MC, MK, MT, NL, NO, PL, PT, RO, RS, SE, SI, SK, SM,

(54) Title: SYSTEMS, DEVICES, AND METHODS FOR ABLATION USING SURGICAL CLAMPS

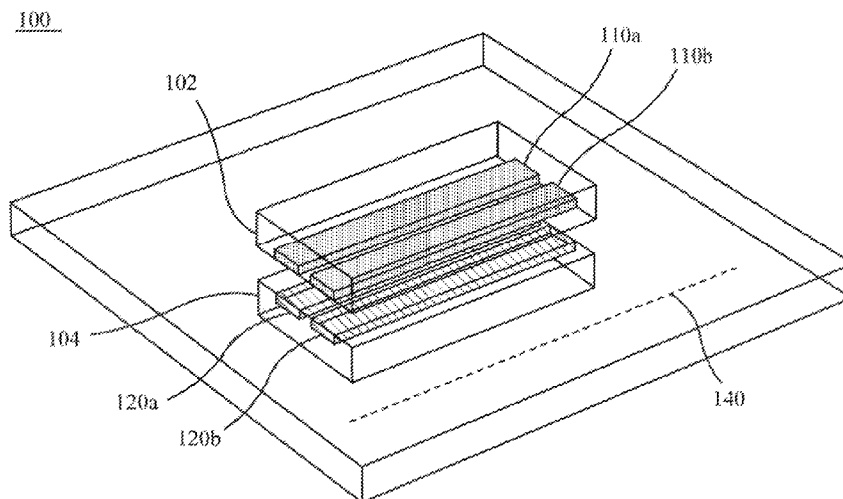


FIG. 1A

(57) Abstract: Systems, devices, and methods for electroporation ablation therapy are disclosed, with the device including a first jaw including a plurality of first electrodes and a second jaw including a plurality of second electrodes. The first jaw and the second jaw may be substantially rigid, elongate, and collectively define a longitudinal axis. The first jaw and the second jaw may be configured to engage tissue therebetween during use.



TR), OAPI (BF, BJ, CF, CG, CI, CM, GA, GN, GQ, GW,  
KM, ML, MR, NE, SN, TD, TG).

**Declarations under Rule 4.17:**

- *as to applicant's entitlement to apply for and be granted a patent (Rule 4.17(ii))*

**Published:**

- *with international search report (Art. 21(3))*
- *before the expiration of the time limit for amending the claims and to be republished in the event of receipt of amendments (Rule 48.2(h))*

## SYSTEMS, DEVICES, AND METHODS FOR ABLATION USING SURGICAL CLAMPS

### CROSS-REFERENCE TO RELATED APPLICATIONS

**[0001]** This application claims the benefit of U.S. Application Serial No. 15/970,404, filed on May 3, 2018, the entire disclosure of which is incorporated herein by reference in its entirety.

### TECHNICAL FIELD

**[0002]** The embodiments described herein relate generally to medical devices for therapeutic electrical energy delivery, and more particularly to a surgical clamp device for delivering electrical energy to ablate tissue.

### BACKGROUND

**[0003]** In the past two decades, the technique of electroporation has advanced from the laboratory to clinical applications, while the effects of brief pulses of high voltages and large electric fields on tissue has been investigated for the past forty years or more. Application of brief, high DC voltages to tissue, thereby generating locally high electric fields typically in the range of hundreds of Volts/centimeter, can disrupt cell membranes by generating pores in the cell membrane. While the precise mechanism of this electrically-driven pore generation (or electroporation) is not well understood, it is thought that the application of relatively large electric fields generates instabilities in the lipid bilayers in cell membranes, causing the occurrence of a distribution of local gaps or pores in the membrane. If the applied electric field at the membrane is larger than a threshold value, the electroporation is irreversible and the pores remain open, permitting exchange of material across the membrane and leading to necrosis and/or apoptosis (cell death). Subsequently the tissue heals in a natural process. While pulsed DC voltages are known to drive electroporation under the right circumstances, known approaches do not provide for ease of navigation, placement and therapy delivery from one or more devices and for safe energy delivery, especially in the context of ablation therapy for cardiac arrhythmias with epicardial catheter devices.

**[0004]** Thus, there is a need for devices that can effectively deliver electroporation ablation therapy selectively to tissue in regions of interest while minimizing damage to healthy tissue. In particular, there is a need for devices that can efficiently deliver electroporation therapy to desired tissue regions while at the same time minimizing the occurrence of irreversible electroporation in undesired tissue regions.

#### SUMMARY

**[0005]** Described here are systems, devices, and methods for ablating tissue through irreversible electroporation. Such electroporation delivery systems, devices, and methods can enhance safety of energy delivery and broaden the areas of clinical application of electroporation including therapeutic treatment of a variety of cardiac arrhythmias. In some embodiments, an apparatus may include a first jaw including a plurality of first electrodes. A second jaw may include a plurality of second electrodes. The first jaw and the second jaw may be substantially rigid, elongate, and may collectively define a longitudinal axis. The first jaw and the second jaw may be further configured to engage tissue therebetween during use. Each electrode of the plurality of first electrodes may have a width orthogonal to the longitudinal axis that is less than a length of that electrode measured parallel to the longitudinal axis. The plurality of first electrodes may be spaced apart laterally with respect to the longitudinal axis. Each electrode of the plurality of second electrodes may have a width orthogonal to the longitudinal axis that is less than a length of that electrode measured parallel to the longitudinal axis. The plurality of second electrodes may be spaced apart laterally with respect to the longitudinal axis. Each electrode of the plurality of first electrodes and the plurality of second electrodes may be configured to deliver a pulse waveform of at least about 200 Volts.

**[0006]** In some embodiments, an apparatus includes a first jaw including a plurality of first electrodes; and a second jaw including a plurality of second electrodes, the first jaw and the second jaw being substantially rigid, elongate, and collectively defining a longitudinal axis, the first jaw and the second jaw further configured to engage tissue therebetween during use. Each electrode of the plurality of first electrodes can have, within a cross-section of the first jaw and the second jaw that is orthogonal to the longitudinal axis, a width that is less than a length of that electrode, the plurality of first electrodes spaced apart laterally with respect to the longitudinal axis. Each electrode of the plurality of second electrodes can have, within the cross-section

orthogonal to the longitudinal axis, a width that is less than a length of that electrode, the plurality of second electrodes spaced apart laterally with respect to the longitudinal axis. The plurality of first electrodes and the plurality of second electrodes can include electrode pairs or sets of electrodes configured to deliver ablative energy to the tissue in response to receiving a pulse waveform having an amplitude of at least about 200 Volts, at least one electrode pair or set of electrodes including an electrode of the plurality of first electrodes and an electrode of the plurality of second electrodes disposed diagonally across from one another within the cross-section orthogonal to the longitudinal axis.

**[0007]** In some embodiments, each electrode of the plurality of first electrodes and the plurality of second electrodes may be independently addressable. In some embodiments, the longitudinal axis has one or more of a straight portion and curved portion. In some embodiments, an electrode of the plurality of first electrodes may be configured as an anode and an electrode from the plurality of second electrodes may be configured as a cathode, the anode being disposed directly across from the cathode. In some embodiments, an electrode from the plurality of first electrodes may be configured as an anode and another electrode from the plurality of first electrodes is configured as a cathode. The anode may be spaced apart laterally from the cathode. In some embodiments, at least two of the plurality of first electrodes may be spaced apart by a first measure. The first jaw and the second jaw may be spaced apart by a second measure, e.g., when engaged with tissue therebetween during use. A ratio of the second measure to the first measure may be between about 0.1:1 and about 12:1. In some embodiments, a distance between a midpoint of at least two of the plurality of first electrodes in a cross-section orthogonal to the longitudinal axis may be between about 1 mm and about 10 mm.

**[0008]** In some embodiments, any two adjacent electrodes of the plurality of first electrodes may be spaced apart by a first measure of between about 0.5 mm and about 10 mm and any two adjacent electrodes of the plurality of second electrodes may be spaced apart by a second measure of between about 0.5 mm and about 10 mm. In some embodiments, any two adjacent electrodes of the plurality of first electrodes may be spaced apart by a first measure and any two adjacent electrodes of the plurality of second electrodes are spaced apart by a second measure. A ratio of the first measure to the second measure may be between about 0.05:1 and about 20:1.

**[0009]** In some embodiments, any two adjacent electrodes of the plurality of first electrodes may be spaced apart by a first measure and any two adjacent electrodes of the plurality of second electrodes may be spaced apart by a second measure. A ratio of the width of any electrode of the plurality of first electrodes to the width of any electrode of the plurality of second electrodes to the first measure may be between about 0.01:1 and about 10:1. In some embodiments, each electrode of the plurality of first electrodes and the plurality of second electrodes may have a length of between about 10 mm and about 120 mm.

**[0010]** In some embodiments, the first and second jaws may be configured to transition between a first configuration for positioning the first and second jaws through or around a body cavity, organ system, or anatomical structure and a second configuration for engaging the tissue. In some embodiments, the first and second jaws may be spaced apart by a spacing distance in the second configuration. In some embodiments, the cross-section (or cross-sectional shape) of each electrode of the plurality of first electrodes and the plurality of second electrodes may be substantially rectangular. In some embodiments, each electrode of the plurality of first electrodes and the plurality of second electrodes may include a curved portion. In some of these embodiments, the curved portion may have a radius of curvature of about 1 cm or larger. In some embodiments, the curved portion may have a J shape.

**[0011]** In some embodiments, each electrode of the plurality of first electrodes and the plurality of second electrodes may include an exposed portion in electrical contact with the tissue during use. In some of these embodiments, the exposed portion of each electrode of the plurality of first electrodes and the plurality of second electrodes may be flat or convex. In some embodiments, the first and second jaws may be parallel, e.g., extend in parallel to one another. In some embodiments, a pulse generator may include a generator. The generator may be coupled to each electrode of the plurality of first electrodes and the plurality of second electrodes. The controller may include a processor and memory. The generator may be configured to generate a pulse waveform of at least about 200 Volts. A first set of electrodes of the plurality of first electrodes and the plurality of second electrodes may be configured for pulse waveform delivery. In some embodiments, the pulse waveform may be delivered to the first set of electrodes. In some of these embodiments, the generator may be further configured to configure a second set of electrodes of the plurality of first electrodes and the plurality of second

electrodes for receiving electrical activity of tissue, and receive signal data corresponding to electrical activity of the tissue using the second set of electrodes. Electrocardiography data may be generated using the signal data.

**[0012]** In some embodiments, a handle may be coupled to the first jaw and the second jaw. In some of these embodiments, the handle may include one or more of a jaw control, electrode selection control, and pulse waveform control. In some embodiments, a pivot may couple the first jaw to the second jaw. In some embodiments, a spring may be configured to bias the first and second jaws closed. In some embodiments, one or more lead wires may be coupled to the plurality of first electrodes and the plurality of second electrodes.

**[0013]** In some embodiments, an apparatus may include a first jaw including a first electrode and a second electrode. A second jaw may include a third electrode and a fourth electrode. The first jaw and the second jaw may be substantially rigid, elongate, and collectively define a longitudinal axis. The first jaw and the second jaw may be further configured to engage tissue therebetween during use. The first electrode may be disposed directly across the third electrode. The second electrode may be disposed directly across the fourth electrode. A processor may be operably coupled to the first jaw and the second jaw. The processor may be configured to, during use, configure the first electrode as an anode and the third electrode as a cathode. Pulsed electric field ablative energy may be delivered via the first electrode and the third electrode.

**[0014]** In some embodiments, each of the first electrode, second electrode, third electrode, and fourth electrode are independently addressable. In some embodiments, the longitudinal axis may have one or more of a straight portion and a curved portion. In some embodiments, the first electrode and the second electrode may be spaced apart by a first measure of between about 0.5 mm and about 10 mm, and the third electrode and the fourth electrode may be spaced apart by a second measure of between about 0.5 mm and about 10 mm. In some embodiments, the first electrode and the second electrode may be spaced apart by a first measure and the third electrode and the fourth electrode may be spaced apart by a second measure. A ratio of the first measure to the second measure may be between about 0.05:1 and about 20:1. In some embodiments, the first electrode and the second electrode may be spaced apart by a first measure. A ratio of a width of the first electrode to the first measure may be between about 0.01:1 and about 10:1. In

some embodiments, the first, second, third, and fourth electrode may each have a length of between about 10 mm and about 120 mm.

**[0015]** In some embodiments, the first and second jaws may be configured to transition between a first configuration for positioning the first and second jaws through or around a body cavity, organ system, or anatomical structure and a second configuration for engaging the tissue. In some of these embodiments, the first and second jaws may be spaced apart by a spacing distance in the second configuration. In some embodiments, the cross-section of the first, second, third, and fourth electrodes may be substantially rectangular. In some embodiments, the first, second, third, and fourth electrodes may include a curved portion.

**[0016]** In some of these embodiments, the curved portion may have a radius of curvature of about 1 cm or larger. In some of these embodiments, the curved portion may have a J shape. In some embodiments, the first, second, third, and fourth electrodes may include an exposed portion in electrical contact with the tissue during use. In some of these embodiments, the exposed portion of each of the electrodes may be flat or convex. In some embodiments, the first and second jaws may be parallel.

**[0017]** In some embodiments, a pulse generator may include a controller. The pulse generator may be coupled to the first, second, third, and fourth electrodes. The controller may include a processor and memory. The generator may be configured to generate a pulse waveform of at least about 200 Volts. A first set of electrodes of the first, second, third, and fourth electrodes may be configured for pulse waveform delivery. The pulse waveform may be delivered to the first set of electrodes.

**[0018]** In some embodiments, the generator may be further configured to configure a second set of electrodes of the first, second, third, and fourth electrodes for receiving electrical activity of tissue. Signal data may be received corresponding to electrical activity of the tissue using the second set of electrodes. Electrocardiography data may be generated using the signal data.

**[0019]** In some embodiments, a handle may be coupled to the first jaw and the second jaw. In some of these embodiments, the handle may include one or more of a jaw control, electrode selection control, and pulse waveform control. In some embodiments, a pivot may couple the first jaw to the second jaw. In some embodiments, a spring may be configured to bias the first

and second jaws closed. In some embodiments, one or more lead wires may be coupled to the first, second, third, and fourth electrodes.

**[0020]** In some embodiments, a method of ablating tissue via irreversible electroporation may include the steps of clamping tissue between a first jaw and a second jaw of an apparatus. The first jaw may include a plurality of first electrodes and the second jaw may include a plurality of second electrodes. The first jaw and the second jaw may be substantially rigid, elongate, and may collectively define a longitudinal axis. Each electrode of the plurality of first electrodes may have a width orthogonal to the longitudinal axis that is less than a length parallel to the longitudinal axis of that electrode. The plurality of first electrodes may be spaced apart laterally with respect to the longitudinal axis. Each electrode of the plurality of second electrodes may have a width orthogonal to the longitudinal axis that is less than a length parallel to the longitudinal axis of that electrode. The plurality of second electrodes may be spaced apart laterally with respect to the longitudinal axis. An electrode of the plurality of first electrodes may be configured as an anode. An electrode of the plurality of second electrodes may be configured as a cathode. The anode and the cathode may be disposed diagonally across the longitudinal axis and may be spaced apart laterally with respect to the longitudinal axis. Ablative energy may be delivered to the tissue via the anode and the cathode.

**[0021]** In some embodiments, the longitudinal axis may have one or more of a straight portion and curved portion. In some embodiments, clamping the tissue may include transitioning the first and second jaws between a first configuration for advancing the apparatus and a second configuration for clamping the tissue. In some embodiments, the tissue may be a region of the atrial base of a pulmonary vein. In some embodiments, the pulse waveform may include a first level of a hierarchy of the pulsed waveform includes a first set of pulses, each pulse having a pulse time duration, and a first time interval separating successive pulses. A second level of the hierarchy of the pulsed waveform may include a plurality of first sets of pulses as a second set of pulses, a second time interval separating successive first sets of pulses, the second time interval being at least three times the duration of the first time interval. A third level of the hierarchy of the pulsed waveform may include a plurality of second sets of pulses as a third set of pulses, a third time interval separating successive second sets of pulses, the third time interval being at least thirty times the duration of the second level time interval.

[0022] In some embodiments, signal data may be received corresponding to electrical activity of the tissue using one or more of the plurality of first electrodes and the plurality of second electrodes. Electrocardiography data may be generated using the signal data. In some embodiments, the first and second jaws may be positioned through or around a body cavity, organ system, or anatomical structure. In some embodiments, each electrode of the plurality of first electrodes and the plurality of second electrodes may be independently addressable.

#### BRIEF DESCRIPTION OF THE DRAWINGS

[0023] FIG. 1A is a schematic perspective view of an ablation device, according to embodiments.

[0024] FIG. 1B is a schematic cross-sectional side view of an ablation device, according to embodiments.

[0025] FIG. 2A is a simulation result in the form of a shaded contour plot of the electric potential in a cross-sectional side view of an ablation device, according to embodiments.

[0026] FIG. 2B is a simulation result in the form of a shaded contour plot of the electric potential in a cross-sectional side view of an ablation device with the electrodes spaced further apart than those in FIG. 2A, according to embodiments.

[0027] FIG. 2C is a simulation result in the form of a shaded contour plot of the electric potential in a cross-sectional side view of an ablation device with the electrodes spaced further apart than those in FIG. 2B, according to embodiments.

[0028] FIG. 3A is a simulation result in the form of a shaded contour plot of the electric potential in a cross-sectional side view of an ablation device, according to embodiments.

[0029] FIG. 3B is a simulation result in the form of a shaded contour plot of the electric potential in a cross-sectional side view of an ablation device with the electrodes spaced further apart than those in FIG. 3A, according to embodiments.

**[0030]** FIG. 3C is a simulation result in the form of a shaded contour plot of the electric potential in a cross-sectional side view of an ablation device with the electrodes spaced further apart than those in FIG. 3B, according to embodiments.

**[0031]** FIG. 4A is a simulation result in the form of a shaded contour plot of the electric potential in a cross-sectional side view of an ablation device, according to embodiments.

**[0032]** FIG. 4B is a simulation result in the form of a shaded contour plot of the electric potential in a cross-sectional side view of an ablation device with the jaws spaced further apart than those in FIG. 4A, according to embodiments.

**[0033]** FIG. 4C is a simulation result in the form of a shaded contour plot of the electric potential in a cross-sectional side view of an ablation device with the jaws spaced further apart than those in FIG. 4B, according to embodiments.

**[0034]** FIG. 4D is a simulation result in the form of a shaded contour plot of the electric potential in a cross-sectional side view of an ablation device with the jaws spaced further apart than those in FIG. 4C, according to embodiments.

**[0035]** FIG. 4E is a simulation result in the form of a shaded contour plot of the electric potential in a cross-sectional side view of an ablation device with the jaws spaced further apart than those in FIG. 4D, according to embodiments.

**[0036]** FIG. 5A is a schematic cross-sectional side view of an ablation device generating an electric field, according to embodiments.

**[0037]** FIG. 5B is a simulation result in the form of a shaded contour plot of the electric potential in a cross-sectional side view of an ablation device with the jaws spaced further apart than those in FIG. 5A, according to embodiments.

**[0038]** FIG. 5C is a simulation result in the form of a shaded contour plot of the electric potential in a cross-sectional side view of an ablation device with the jaws spaced further apart than those in FIG. 5B, according to embodiments.

**[0039]** FIG. 5D is a simulation result in the form of a shaded contour plot of the electric potential in a cross-sectional side view of an ablation device using a higher voltage than applied in FIG. 5C, according to embodiments.

**[0040]** FIG. 5E is a simulation result in the form of a shaded contour plot of the electric potential in a cross-sectional side view of an ablation device with the jaws spaced further apart than those in FIG. 5D, according to embodiments.

**[0041]** FIG. 5F is a simulation result in the form of a shaded contour plot of the electric potential in a cross-sectional side view of an ablation device using a higher voltage than applied in FIG. 5E, according to embodiments.

**[0042]** FIG. 6 is a block diagram of an electroporation system, according to embodiments.

**[0043]** FIG. 7 is a side view of an ablation device, according to embodiments.

**[0044]** FIG. 8 is a perspective view of a distal end of an ablation device, according to embodiments.

**[0045]** FIG. 9A is a perspective view of a distal end of an ablation device, according to embodiments. FIG. 9B is a perspective view of a distal end of an ablation device shown in FIG. 9A having tissue disposed in between the arms of the device, according to embodiments.

**[0046]** FIG. 10 is a perspective view of a distal end of an ablation device having a pulmonary vein disposed between the arms of the device, according to embodiments.

**[0047]** FIG. 11 illustrates a method for tissue ablation, according to embodiments.

**[0048]** FIG. 12 is an example waveform including a sequence of voltage pulses with a pulse width defined for each pulse, according to embodiments.

**[0049]** FIG. 13 schematically illustrates a hierarchy of pulses including pulse widths, intervals between pulses, and groupings of pulses, according to embodiments.

**[0050]** FIG. 14 provides a schematic illustration of a nested hierarchy of monophasic pulses including different levels of the nested hierarchy, according to embodiments.

[0051] FIG. 15 is a schematic illustration of a nested hierarchy of biphasic pulses including different levels of the nested hierarchy, according to embodiments.

[0052] FIG. 16 illustrates schematically a time sequence of electrocardiograms and cardiac pacing signals together with atrial and ventricular refractory time periods and indicating a time window for irreversible electroporation ablation, according to embodiments.

#### DETAILED DESCRIPTION

[0053] Described herein are systems, devices, and methods for selective and rapid application of pulsed electric fields to ablate tissue by irreversible electroporation. Generally, the systems, devices, and methods described herein may be used to generate electric field magnitudes at desired regions of interest while tissue is clamped (e.g., held) in order to treat atrial fibrillation via irreversible electroporation. An ablation device may include a set of jaws or arms each having a set of electrodes that may be configured to hold (e.g., clamp, grasp, compress) a portion of tissue therebetween and provide tissue ablation with reduced energy delivery. The set of electrodes may be configured to contact tissue during use. The jaws may transition from a closed configuration to an open configuration for grasping tissue such as a pulmonary vein. It is understood that the set of jaws may be transformed into any intermediate configuration between the open and closed configurations, continuously or in discrete steps. For example, the jaws may transition from a closed configuration to an open configuration to allow tissue to be placed between the jaws. Then, the jaws may be brought closer together to apply compression force to tissue disposed therebetween to target energy delivery to a desired portion of tissue.

[0054] An irreversible electroporation system as described herein may include a signal generator and a processor configured to apply one or more voltage pulse waveforms to a selected set of electrodes of an ablation device (e.g., clamp, clip, forcep, hemostat) to deliver energy to a region of interest (e.g., portion of a pulmonary vein) and provide a highly configurable a set of electrode channels (e.g., allow independent and arbitrary electrode selection). The ablation device may generally include a pair of opposable members configured to hold tissue therebetween. In some embodiments, the opposable members may be movable relative to each other. The pulse waveforms disclosed herein may aid in therapeutic treatment of a variety of cardiac arrhythmias (e.g., atrial fibrillation). In order to deliver the pulse waveforms generated

by the signal generator, the ablation device may comprise one or more elongate parallel electrodes. In some embodiments, the electrodes may be independently addressable such that each electrode may be controlled (e.g., deliver energy) independently of any other electrode of the device. For example, an anode-cathode energy delivery sequence may be selected to ablate desired regions of tissue and/or to reduce the possibility of shorting. In this manner, the electrodes may deliver different energy waveforms with different timing synergistically for electroporation of tissue.

**[0055]** The term “electroporation” as used herein refers to the application of an electric field to a cell membrane to change the permeability of the cell membrane to the extracellular environment. The term “reversible electroporation” as used herein refers to the application of an electric field to a cell membrane to temporarily change the permeability of the cell membrane to the extracellular environment. For example, a cell undergoing reversible electroporation may observe the temporary and/or intermittent formation of one or more pores in its cell membrane that close up upon removal of the electric field. The term “irreversible electroporation” as used herein refers to the application of an electric field to a cell membrane to permanently change the permeability of the cell membrane to the extracellular environment. For example, a cell undergoing irreversible electroporation may observe the formation of one or more pores in its cell membrane that persist upon removal of the electric field.

**[0056]** Pulse waveforms for electroporation energy delivery as disclosed herein may enhance the safety, efficiency, and effectiveness of energy delivery to tissue by reducing the electric field threshold associated with irreversible electroporation, thus yielding more effective ablative lesions with a reduction in total energy delivered. In some embodiments, the voltage pulse waveforms disclosed herein may be hierarchical and have a nested structure. For example, the pulse waveform may include hierarchical groupings of pulses having associated timescales. In some embodiments, the methods, systems, and devices disclosed herein may comprise one or more of the methods, systems, and devices described in International Application Serial No. PCT/US2016/057664, filed on October 19, 2016, and titled “SYSTEMS, APPARATUSES AND METHODS FOR DELIVERY OF ABLATIVE ENERGY TO TISSUE,” and U.S. Application Serial No. 15/796,375, filed on October 27, 2017, and titled “SYSTEMS, APPARATUSES

AND METHODS FOR DELIVERY OF ABLATIVE ENERGY TO TISSUE,” the contents of each of which are hereby incorporated by reference in their entirety.

**[0057]** In some embodiments, the systems may further include a cardiac stimulator used to synchronize the generation of the pulse waveform to a paced heartbeat. The cardiac stimulator may electrically pace the heart with a cardiac stimulator and ensure pacing capture to establish periodicity and predictability of the cardiac cycle. A time window within a refractory period of the periodic cardiac cycle may be selected for voltage pulse waveform delivery. Thus, voltage pulse waveforms may be delivered in the refractory period of the cardiac cycle to avoid disruption of the sinus rhythm of the heart. The ablation device may transform into different configurations (e.g., compact and expanded) to navigate and position the device within a body cavity. In some embodiments, the system may optionally include one or more return electrodes.

**[0058]** Generally, to ablate tissue, the device may be surgically placed at a target location. In a cardiac application, the electrodes through which the voltage pulse waveform is delivered may be disposed on opposing sides of a pair of jaws of an ablation device. The methods described here may include placing tissue (e.g., pulmonary vein) between the jaws in contact with the electrodes. A pulse waveform may be generated and delivered to one or more electrodes of the device to ablate tissue. In some embodiments, the pulse waveform may be generated in synchronization with a pacing signal of the heart to avoid disruption of the sinus rhythm of the heart. In some embodiments, the electrodes may be configured in anode-cathode (e.g., bipole) subsets. The pulse waveform may include hierarchical waveforms to aid in tissue ablation and reduce damage to healthy tissue.

## I. Systems

### Overview

**[0059]** Disclosed herein are systems and devices configured for tissue ablation via the selective and rapid application of voltage pulse waveforms to aid tissue ablation, resulting in irreversible electroporation. Generally, a system for ablating tissue described here may include a signal generator and an ablation device having one or more electrodes for the selective and rapid application of DC voltage to drive electroporation. Voltages may be applied to a selected subset of the electrodes, with independent subset selections for anode and cathode electrode selections.

The ablation device may be coupled to one or more electrode channels of the signal generator. Each electrode channel may be independently configured as an anode or cathode and a voltage pulse waveform may be delivered through one or more of the electrode channels in a predetermined sequence. A pacing signal for cardiac stimulation may be generated and used to generate the pulse waveform by the signal generator in synchronization with the pacing signal.

**[0060]** Generally, the systems and devices described herein include one or more ablation devices configured to ablate tissue held between jaws of the device. FIG. 7 is a side view of an ablation device (700) configured to hold tissue and deliver energy for tissue ablation. The ablation device (700) may include a first jaw (710) and a second jaw (712) coupled to a distal end of a body (e.g., shaft, elongate member) (720). A proximal end of the body (720) may be coupled to a handle (730). In some embodiments, the handle (730) may include an actuator (740) that may be configured to control one or more of the jaws (710, 720) and energy delivery, as described in more detail herein. In some embodiments, the actuator (740) may include an input device such as one or more of a lever, trigger, button, slide, switch, and the like. For example, a user may engage the actuator to transition and hold the jaws in an open configuration to permit the release of tissue held therebetween. When a desired portion of tissue is positioned between the open jaws, the user may disengage the actuator to transition the jaws to a closed configuration suitable for tissue ablation. Alternatively, a user may engage the actuator to transition the jaws from an open configuration to a closed configuration to allow, for example, the device to be advanced into a body cavity. When the device is adjacent to a desired portion of tissue, the user may disengage the actuator to transition the jaws to an open configuration to allow the desired portion of tissue to be positioned between the open jaws. With the tissue disposed between the jaws, the user may then engage the actuator to transition the jaws to a closed configuration suitable for tissue ablation.

**[0061]** In some embodiments, the actuator may be configured for direct movement of the jaws such that when engaged, the actuator causes the jaws to move in a 1:1 ratio or some other ratio. That is, the actuator may be configured to limit, attenuate, and/or amplify a force applied by the jaws based on an amount of force applied to the actuator. In some embodiments, the ablation device (740) may include a spring configured to bias the jaws (710, 720) between different configurations. For example, a spring may be coupled to the jaws (710, 720) and be configured

to bias the jaws (710, 720) towards the tissue ablation configuration in order to apply a compressive force to tissue held between the jaws (710, 720) when the ablation device is advanced into or retracted from a body cavity, the jaws may transition to a closed configuration where the jaws contact each other.

**[0062]** FIG. 6 illustrates an ablation system (600) configured to deliver voltage pulse waveforms for tissue ablation. The system (600) may include a signal generator (610), ablation device (640), and optionally a cardiac stimulator (650). The signal generator (610) may be coupled to at least one ablation device (640), and optionally to the cardiac stimulator (650). The ablation device (640) may include a first jaw (650a) and a second jaw (650b). The first jaw (650a) may include a set of one or more electrodes (642a, 642b, ..., 642n). The second jaw (650a) may include a set of one or more electrodes (644a, 644b, ..., 644n).

#### Signal Generator

**[0063]** The signal generator (610) may be configured to generate pulse waveforms for irreversible electroporation of tissue, such as, for example, heart tissue. The signal generator (610) may be a voltage pulse waveform generator and deliver a pulse waveform to a set of electrodes (642a, 642b, ..., 642n, and 644a, 644b, ..., 644n) of the ablation device (640). The signal generator (610) may generate and deliver several types of signals including, but not limited to, radiofrequency (RF), direct current (DC) impulses (such as high-voltage, ultra-short pulses used in electroporation), stimulus range impulses, and/or hybrid electrical impulses. For example, the signal generator (610) may generate monophasic (DC) pulses or biphasic pulses (pulses of both polarities). The signal generator (610) may include a processor (620), memory (622), a set of electrode channels (624a, 624b, ..., 624n, and 625a, 625b, ..., 625n), energy source (626), sensing circuit (628), routing console (630), and user interface (632). One or more signal generator components may be coupled using a communication bus. The processor (620) may incorporate data received from one or more of memory (622), electrode channels (624a, 624b, ..., 624n, and 625a, 625b, ..., 625n), energy source (626), sensing circuit (628), routing console (630), user interface (632), ablation device (640), and cardiac stimulator (650) to determine the parameters (e.g., amplitude, width, duty cycle, timing, etc.) of the voltage pulse waveform to be generated by the signal generator (610). The memory (622) may further store instructions to cause the processor (620) to execute modules, processes and/or functions

associated with the system (600), such as pulse waveform generation and delivery, electrode channel configuration, and/or cardiac pacing synchronization. For example, the memory (622) may be configured to store anode/cathode configuration data, electrode channel configuration data, pulse waveform data, fault data, energy discharge data, heart pacing data, patient data, clinical data, procedure data, electromyography data, sensor data, temperature data, and/or the like.

**[0064]** In some embodiments, the ablation device (640) may include a catheter configured to receive and/or deliver the pulse waveforms described herein. For example, the ablation device (640) may be introduced into an epicardial space of the left atrium and positioned to align one or more electrodes (642a, 642b, ..., 642n, and 644a, 644b, ..., 644n) to heart tissue (e.g., pulmonary vein), and then deliver the pulse waveforms to ablate tissue. The ablation device (140) may include one or more electrodes (642a, 642b, ..., 642n, and 644a, 644b, ..., 644n), which may, in some embodiments, be a set of independently addressable electrodes. For example, the electrodes (642a, 642b, ..., 642n, and 644a, 644b, ..., 644n) may be grouped into one or more anode-cathode subsets such as, for example, a subset including one anode and one cathode, a subset including two anodes and two cathodes, a subset including two anodes and one cathode, a subset including one anode and two cathodes, a subset including three anodes and one cathode, a subset including three anodes and two cathodes, and/or the like. The set of electrodes (642a, 642b, ..., 642n, and 644a, 644b, ..., 644n) may include any number of electrodes, for example, 2, 3, 4, 5, 6, 7, 8, 9, 10, 12, or more electrodes. In some embodiments, the methods, systems, and devices disclosed herein may comprise one or more of the methods, systems, and devices described in International Patent Application Serial No. PCT/US2018/029552, filed on April 26, 2018, and titled "SYSTEMS, DEVICES, AND METHODS FOR SIGNAL GENERATION," International Application Serial No. PCT/US2019/014226, filed on January 18, 2019, and titled "SYSTEMS, DEVICES, AND METHODS FOR FOCAL ABLATION," and International Application Serial No. PCT/US2013/031252, filed on March 14, 2013, and titled "CATHETERS, CATHETER SYSTEMS, AND METHODS FOR PUNCTURING THROUGH A TISSUE STRUCTURE AND ABLATING A TISSUE REGION," the contents of which are hereby incorporated by reference in their entirety.

**[0065]** In some embodiments, the processor (620) may be any suitable processing device configured to run and/or execute a set of instructions or code and may include one or more data processors, image processors, graphics processing units, physics processing units, digital signal processors, and/or central processing units. The processor (620) may be, for example, a general purpose processor, Field Programmable Gate Array (FPGA), an Application Specific Integrated Circuit (ASIC), and/or the like. The processor (620) may be configured to run and/or execute application processes and/or other modules, processes and/or functions associated with the system and/or a network associated therewith (not shown). In some embodiments, the processor may comprise both a microcontroller unit and an FPGA unit, with the microcontroller sending electrode sequence instructions to the FPGA. The underlying device technologies may be provided in a variety of component types, e.g., metal-oxide semiconductor field-effect transistor (MOSFET) technologies like complementary metal-oxide semiconductor (CMOS), bipolar technologies like emitter-coupled logic (ECL), polymer technologies (e.g., silicon-conjugated polymer and metal-conjugated polymer-metal structures), mixed analog and digital, and/or the like.

**[0066]** In some embodiments, the memory (622) may include a database (not shown) and may be, for example, a random access memory (RAM), a memory buffer, a hard drive, an erasable programmable read-only memory (EPROM), an electrically erasable read-only memory (EEPROM), a read-only memory (ROM), Flash memory, etc. The memory (622) may store instructions to cause the processor (620) to execute modules, processes and/or functions associated with the system (600), such as pulse waveform generation, electrode channel configuration, and/or cardiac pacing.

**[0067]** In some embodiments, a set of electrode channels (624a, 624b, ..., 624n, and 625a, 625b, ..., 625n) may include a set of active solid-state switches. The set of electrode channels (624a, 624b, ..., 624n, and 625a, 625b, ..., 625n) may be configured in a number of ways, including independent anode/cathode configuration for each electrode channel. For example, the electrode channels (624a, 624b, ..., 624n, and 625a, 625b, ..., 625n) may be grouped into one or more anode-cathode subsets such as, for example, a subset including one anode and one cathode, a subset including two anodes and two cathodes, a subset including two anodes and one cathode, a subset including one anode and two cathodes, a subset including three anodes and one cathode,

a subset including three anodes and two cathodes, and/or the like. The set of electrode channels (624a, 624b, ..., 624n, and 625a, 625b, ..., 625n) may include any number of channels, for example, 2, 3, 4, 5, 6, 7, 8, 9, 10, 12, or more electrode channels. Energy delivery may use any combination of electrode channels (624a, 624b, ..., 624n, and 625a, 625b, ..., 625n) and any order for an energy delivery sequence.

**[0068]** The set of electrode channels (624a, 624b, ..., 624n, and 625a, 625b, ..., 625n) may be coupled to a routing console (630) to deliver energy to a set of electrodes (642) coupled to the routing console (630). The set of electrode channels (624a, 624b, ..., 624n, and 625a, 625b, ..., 625n) may be coupled to an energy source (626) to receive energy (e.g., a pulse waveform). Processor (620) may be coupled to each electrode channel (624a, 624b, ..., 624n, and 625a, 625b, ..., 625n) to configure an anode/cathode configuration for each electrode channel (624), which may be configured on a per pulse basis, per operator input, and/or the like. The processor (620) and energy source (626) may be collectively configured to deliver a pulse waveform to the set of electrodes (642, 644) through the set of electrode channels (624a, 624b, ..., 624n, and 625a, 625b, ..., 625n). In some embodiments, each electrode channel (624a, 624b, ..., 624n, and 625a, 625b, ..., 625n) may include an electronic switch (e.g., bipolar transistor) and a drive circuit, as described in detail herein. In some embodiments, each electrode channel (624a, 624b, ..., 624n, and 625a, 625b, ..., 625n) may have a bootstrap configuration for low and high frequency operation. For example, the pulse duration of voltage pulses delivered through an electrode channel may be in the range of between about 1 microsecond and about 1000 microseconds. In biphasic mode, this corresponds to an approximate frequency range of between about 500 Hz and about 500 KHz for the frequency associated with the voltage pulses.

**[0069]** In some embodiments, a pulse generator including a controller with the processor (620) and memory (622) may be coupled to each electrode of the set of first electrodes (642) and the set of second electrodes (644). The pulse generator and/or controller may be configured to generate a pulse waveform, configure a first set of electrodes of the set of first electrodes (642) and the set of second electrodes (644) for pulse waveform delivery. The pulse waveform may be delivered to the first set of electrodes (642). In some embodiments, a second set of electrodes of the set of first electrodes (642) and the set of second electrodes (644) may be configured for receiving electrical activity of tissue. Signal data corresponding to the electrical activity of the

tissue may be received using the second set of electrodes. Electrocardiography data may be generated using the signal data.

**[0070]** In some embodiments, an energy source (626) may be configured to convert and supply energy to a set of electrodes (642, 644) coupled to the signal generator (610). The energy source (626) of the signal generator (610) may include a DC power supply and be configured as an AC/DC switcher. In some embodiments, an energy source (626) of the signal generator (610) may deliver rectangular-wave pulses with a voltage in the range between about 300 V and about 5000 V. In some of these embodiments, the energy source (626) may be configured to store energy. For example, the energy source (626) may include one or more capacitors to store energy from a power supply. While these examples are included for purely non-limiting illustrative purposes, it is noted that a variety of pulse waveforms with a range of pulse durations, intervals between pulses, pulse groupings, etc. may be generated depending on the clinical application.

**[0071]** In some embodiments, a sensing circuit (628) may be configured to determine an amount of current being delivered to a device coupled to the signal generator (610) (e.g., electrode (642) coupled to the electrode channel (624)). As described in more detail herein, the sensing circuit (628) may also be used to classify an electrode channel fault, monitor capacitor discharge, and/or sense arcing. In some embodiments, the sensing circuit (628) may be a direct current sensing circuit and/or a low-side sensing circuit. The sensing circuit may include one or more operational amplifiers, difference amplifiers (DA), instrumentation amplifiers (IA), and/or current shunt monitors (CSM).

**[0072]** In some embodiments, the routing console (630) may be configured to electrically couple a set of electrodes (642) of an ablation device (640) to a set of electrode channels (624a, 624b, ..., 624n, and 625a, 625b, ..., 625n). The routing console (630) may be configured to selectively deliver energy to the set of electrodes (642) using the set of electrode channels (624a, 624b, ..., 624n, and 625a, 625b, ..., 625n). One or more ablation devices (640) each having a set of electrodes (642, 644) may be coupled to the routing console (630). The set of electrodes (642, 644) may include any number of electrodes, for example, 1, 2, 3, 4, 5, 6, 7, 8, 9, 10, 12, or more electrodes. In some embodiments, an ablation device (640) may include three electrodes with a

first jaw (650a) having a first electrode (642a) and a second jaw (650b) having a second electrode (644a) and a third electrode (644b).

**[0073]** In some embodiments, the electrode channels (624a, 624b, ..., 624n, and 625a, 625b, ..., 625n) configured for energy delivery (e.g., configured as an anode/cathode pair of electrode channels) may not be adjacent to each other. For example, the set of electrode channels (624a, 624b, ..., 624n, and 625a, 625b, ..., 625n) may include a set of N electrode channels (624a, 624b, ..., 624n, and 625a, 625b, ..., 625n) in a parallel array. In one embodiment, a first electrode channel may correspond to a first electrode channel (624a) in the parallel array of N electrode channels (624a, 624b, ..., 624n, and 625a, 625b, ..., 625n). One or more of a second and third electrode channel (624b, 624c) may not be adjacent to the first electrode channel (624a) in the parallel array of N electrode channels (624a, 624b, ..., 624n, and 625a, 625b, ..., 625n).

**[0074]** A multi-electrode ablation device may allow targeted and precise energy delivery to tissue. In some embodiments, the electrodes (642, 644) of an ablation device (640) may be configured for energy delivery (e.g., as an anode/cathode pair of electrodes (642, 644)) and may be disposed on opposing jaws on respective parallel arrays of the ablation device (640). For example, an ablation device (640) may include a first jaw (650a) having a set of first electrodes (642) as a parallel array of N electrodes (642n) and a second jaw (650b) having a set of second electrodes (644) as a parallel array of M electrodes (644n). The signal generator (610) coupled to the ablation device (640) may include a set of electrode channels (624a, 624b, ..., 624n, and 625a, 625b, ..., 625n) having N electrode channels corresponding to the M electrodes (642n, 644n) of the ablation device (640). In one embodiment, the first electrode channel (624a) of the N electrode channels (624a, 624b, ..., 624n, and 625a, 625b, ..., 625n) may correspond to a first electrode (642a) in the parallel array of M electrodes (642n) of the first jaw (650a). One or more of second and third electrode channel (624b, 624c) of the N electrode channels (624n) may not correspond to any of the electrodes adjacent to the first electrode (642a) in the parallel array of M electrodes (642n). For example, the second electrode channel (624b) may correspond to a second electrode (644a) in the parallel array of M electrodes (644n) of the second jaw (650b).

**[0075]** Configurable electrode channel and electrode selection may provide flexibility in positioning the electrodes for ablating a desired region of interest, as described in more detail

herein. In some embodiments, the routing console (630) may couple to a set of four or six electrodes (642, 644) of an ablation device (640). The routing console (630) may receive input from the processor (620) and/or user interface (632) for electrode channel selection and energy delivery to one or more electrodes (642, 644). Additionally or alternatively, the routing console (630) may couple to a cardiac stimulator (650) and be configured to receive data from devices (e.g., heart pacing data from a pacing device) used for synchronization of a pulse waveform with a patient cardiac cycle.

**[0076]** In some embodiments, a user interface (632) may be configured as a communication interface between an operator and the system (600). The user interface (632) may include an input device and output device (e.g., touch surface and display). For example, patient data from memory (622) may be received by user interface (632) and output visually and/or audibly. Electric current data from sensing circuit (628) may be received and output on a display of user interface (632). As another example, operator control of an input device having one or more buttons, knobs, dials, switches, trackball, touch surface, and/or the like, may generate a control signal to the signal generator (610) and/or ablation device (640).

**[0077]** In some embodiments, an input device of the user interface (632) may include a touch surface for operator input and may be configured to detect contact and movement on the touch surface using any of a plurality of touch sensitivity technologies including capacitive, resistive, infrared, optical imaging, dispersive signal, acoustic pulse recognition, and surface acoustic wave technologies. Additionally or alternatively, the user interface (632) may include a step switch or foot pedal.

**[0078]** In some embodiments, an output device of the user interface (632) may include one or more of a display device and audio device. The display device may include at least one of a light emitting diode (LED), liquid crystal display (LCD), electroluminescent display (ELD), plasma display panel (PDP), thin film transistor (TFT), and organic light emitting diodes (OLED). An audio device may audibly output patient data, sensor data, system data, other data, alarms, warnings, and/or the like. The audio device may include at least one of a speaker, piezoelectric audio device, magnetostrictive speaker, and/or digital speaker. In one embodiment, the audio device may output an audible warning upon detection of a fault in the signal generator (610) and/or ablation device (640).

**[0079]** In some embodiments, the signal generator (610) may be mounted on a trolley or cart. In some embodiments, the user interface (632) may be formed in the same or different housing as the signal generator (610). The user interface (632) may be mounted to any suitable object, such as furniture (e.g., a bed rail), a wall, a ceiling, or may be self-standing. In some embodiments, the input device may include a wired and/or wireless transmitter configured to transmit a control signal to a wired and/or wireless receiver of the signal generator (610).

**[0080]** In some embodiments, a cardiac stimulator (650) including a pacing device may be configured to generate a heart pacing signal to be delivered to a patient via the pacing device. An indication of the pacing signal may be transmitted by the cardiac stimulator (650) to the signal generator (610). Based on the pacing signal, an indication of a voltage pulse waveform may be selected, computed, and/or otherwise identified by the processor (620) and generated by the signal generator (610). In some embodiments, the signal generator (610) may be configured to generate the voltage pulse waveform in synchronization with the indication of the pacing signal (e.g., within a common refractory window). For example, in some embodiments, the common refractory window may start substantially immediately following a ventricular pacing signal (or after a very small delay) and last for a duration of between about 150 ms and about 250 ms thereafter. In such embodiments, an entire pulse waveform may be delivered within this duration.

**[0081]** In some embodiments, the systems described herein may include one or more sterile coverings configured to create a sterile barrier around portions of the system (600). In some embodiments, the system (600) may include one or more sterile coverings to form a sterile field. For example, a sterile covering may be placed over the user interface of the signal generator. The sterile covering may include, for example, a sterile drape configured to cover at least a portion of a system component. In one embodiment, a sterile covering (e.g., sterile drape) may be configured to create a sterile barrier with respect to a user interface (632) of the system (600). The sterile drape may be clear and allow an operator to visualize and manually manipulate the user interface (632). The sterile covering may conform tightly around one or more system components or may drape loosely to allow components to be adjusted within the sterile field.

## Ablation Device

**[0082]** The systems described here may include one or more multi-electrode ablation devices configured to ablate tissue for treating atrial fibrillation. Generally, the ablation devices may include a first jaw and a second jaw sized and shaped to physically engage, hold, and (optionally) compress tissue therebetween for delivery of ablation energy. In some embodiments, a distal end of the first jaw and the second jaw may be generally atraumatic to decrease the risk of damage to tissue through laceration, puncture, and other damage when releasably coupled thereto. For example, the first jaw and second jaw may form atraumatic surfaces and edges (e.g., rounded, blunt) to contact and/or hold tissue without causing damage. A set of metallic electrodes disposed on each of the jaws and may also be generally atraumatic to decrease the risk of damage to tissue through laceration and puncture. For example, the edges of the electrodes may be rounded to reduce tissue damage and to increase the uniformity of the electric field generated at a central portion and a peripheral portion of the electrodes. The electrodes may generally form an elongate member (e.g., bar, strip) that extends generally parallel to a length of the jaws. The electrodes may have a length greater than a width or height/depth dimension of the electrode. The jaws as described in more detail herein may be composed of an electrically insulating material such as a polymeric or ceramic material.

**[0083]** In order to deliver the pulse waveforms generated by the signal generator, one or more electrodes of the ablation device may have an insulated electrical lead configured for sustaining a voltage potential of at least about 300 V without dielectric breakdown of its corresponding insulation. In some embodiments, the insulation on each of the electrical leads may sustain an electrical potential difference of between about 200 V to about 3,000 V across its thickness without dielectric breakdown, including all values and sub-ranges in between. In some embodiments, the electrodes may be independently addressable such that each electrode may be controlled (e.g., deliver energy) independently of any other electrode of the device. In this manner, the electrodes may deliver different energy waveforms with different timing synergistically for electroporation of tissue. The electrodes may, for example, be connected to an insulated electrical lead leading to a handle to receive pulse waveforms generated by a signal generator as discussed above with respect to FIG. 6.

**[0084]** FIG. 1A is a schematic perspective view of an exemplary ablation device (100) including a first jaw (102) and a second jaw (104) that may be structurally and/or functionally similar to the ablation device in FIG. 6. The first jaw (102) may include a set of first electrodes (110a, 110b, ..., 110n) (e.g., first plurality of electrodes) and the second jaw (104) may include a set of second electrodes (120a, 120b, ..., 120n) (e.g., second plurality of electrodes), as shown in FIG. 1B. The first jaw (102) and the second jaw (104) may be spaced apart and substantially parallel (e.g., extend parallel to one another) and configured to engage tissue (130) therebetween during use. In some embodiments, the first jaw (102) and the second jaw (104) may transition between a set of configurations having different jaw measures (132) (e.g., spacing, distance). In some embodiments, the first jaw (102) and second jaw (104) may be configured to transition between a first configuration for passing the first and second jaws through a body cavity, organ system, or anatomical structure and a second configuration for engaging the tissue (130). The first jaw (102) and the second jaw (104) may be spaced apart by a spacing distance in the second configuration (e.g., third measure (132) as described in more detail herein). The first jaw (102) and the second jaw (104) may be collectively configured to define a longitudinal axis (140). The first jaw (102) and the second jaw (104) may be substantially rigid.

**[0085]** The set of first electrodes (110) and the set of second electrodes (120) may be arranged parallel to the longitudinal axis (140) of the jaws (102, 104). Each of the first electrodes (110) may be spaced apart from an adjacent first electrode (110) by a first measure (106) (e.g., spacing, distance) and each of the second electrodes (120) may be spaced apart from an adjacent second electrode (120) by a second measure (108). The set of first electrodes (110) may be disposed on a side of the first jaw (102) facing the second jaw (104) with each of the set of first electrodes (110) spaced apart laterally with respect to the longitudinal axis (140). Similarly, the set of second electrodes (120) may be disposed on a side of the second jaw (104) facing the first jaw (102) with each of the set of second electrodes (120) spaced apart laterally with respect to the longitudinal axis (140). As shown in FIG. 1B, each electrode of the set of first electrodes (110) and the set of second electrodes (120) may include an exposed portion in electrical contact with tissue (130) during use. The exposed portion of each electrode of the set of first electrodes (110) and the set of second electrodes (120) may be flat or convex.

**[0086]** At least two of the set of first electrodes (110) may be spaced apart by a first measure (106), and at least two of the set of second electrodes (120) may be spaced apart by a second measure (108), as shown in FIG. 1B. The first jaw (102) and the second jaw (104) may be spaced apart by a third measure (132). For example, the set of first electrodes may be spaced apart by a distance between about 1 mm and about 6 mm, while the set of second electrodes may be spaced apart by a distance between about 1 mm and about 4 mm. The first jaw and the second jaw may be spaced apart by a distance between about 1 mm and about 15 mm.

**[0087]** In some embodiments, each electrode of the set of first electrodes (110) and the set of second electrodes (120) may have a width orthogonal to the longitudinal axis that is less than a length of that electrode that is parallel to the longitudinal axis (140) where the set of first electrodes (110) are spaced apart laterally with respect to the longitudinal axis (140). In particular, each electrode of the set of first electrodes (110) has, within a cross-section of the apparatus (e.g., a cross-section of the first jaw (102) and the second jaw (104)) that is orthogonal to the longitudinal axis, a width that is less than a length of that electrode, where the set of first electrodes (110) are spaced apart laterally. In some embodiments, any two adjacent electrodes of the set of first electrodes (110) may have a first measure of between about 0.5 mm and about 10 mm and any two adjacent electrodes of the set of second electrodes (120) may have a second measure of between about 0.5 mm and about 10 mm.

**[0088]** In some embodiments, each electrode of the set of first electrodes (110) and the set of second electrodes (120) may have a length of between about 1 cm and about 8 cm, a width of between about 1 mm and about 5 mm, and a height of between about 0.5 mm and about 3 mm. In some embodiments, the set of first electrodes (110) and the set of second electrodes (120) may have a length to width ratio of at least about 3:1.

**[0089]** The set of first electrodes (110) and the set of second electrodes (120) may have a shape of an elongate electrode. In some embodiments, each electrode of the set of first electrodes (110) and the set of second electrodes (120) may be substantially rectangular, e.g., have a cross-sectional shape that is rectangular. In other embodiments, each electrode of the set of first electrodes (110) and the set of second electrodes (120) may include a curved portion.

**[0090]** In some embodiments, each electrode of the set of first electrodes (110) and the set of second electrodes (120) may be independently addressable. One or more lead wires may be coupled to the set of first electrodes (110) and the set of second electrodes (120). In some embodiments, the electrodes may comprise a generally elliptical or circular cross-section. A length of a semi-major axis of the electrode may be between about 0.5 mm and about 5 mm. In some of these embodiments, a length to width ratio of the electrode may be at least about 3:1.

**[0091]** In some embodiments, an electrode of the set of first electrodes (110) may be configured as an anode and an electrode of the set of second electrodes (120) may be configured as a cathode. For example, the anode may be disposed directly across from the cathode. For example, a first electrode pairing may include electrodes (110a, 120a) directly across from each other on opposing jaws (102, 104) within the cross-section of FIG. 1B (e.g., a cross-section of the opposing jaws (102, 104)) orthogonal to the longitudinal axis, a second electrode pairing may include electrodes (110b, 120b) directly across from each other on opposing jaws (102, 104) within the cross-section orthogonal to the longitudinal axis, and so forth for n electrodes.

**[0092]** In other embodiments, the anode may be diagonal from the cathode within the cross-section orthogonal to the longitudinal axis. In some embodiments, the anode may generally be spaced apart laterally from the cathode with respect to the longitudinal axis. In some embodiments, a first electrode pairing may include electrodes (110a, 120b) spaced apart laterally from each other on opposing jaws (102, 104) within the cross-section orthogonal to the longitudinal axis and a second electrode pairing may include electrodes (110b, 120a) spaced apart laterally from each other on opposing jaws (102, 104) with respect to the longitudinal axis, and so forth for n electrodes.

**[0093]** In some embodiments, one electrode of the set of first electrodes (110) may be configured as an anode while another electrode of the set of first electrodes (110) may be configured as a cathode. In some embodiments, one electrode of one of the jaws may be configured as an anode while another electrode of the same jaw may be configured as a cathode. In some embodiments, a first electrode pairing may include electrodes (110a, 110b) adjacent to each other on the same first jaw (102) within the cross-section orthogonal to the longitudinal axis, a second electrode pairing may include electrodes (120a, 120b) adjacent to each other on

the same second jaw (104) within the cross-section orthogonal to the longitudinal axis, and so forth for n electrodes.

**[0094]** A pre-determined ablation sequence may include delivering ablation pulse waveforms over a sequence of pre-defined electrode pairings. In some embodiments, the sequenced delivery may be triggered from a cardiac stimulator and/or pacing device. In some embodiments, the ablation pulse waveforms may be applied in a refractory period of the cardiac cycle to avoid disruption of the sinus rhythm of the heart, as described in more detail herein. One or more of the electrodes may be configured to receive signal data corresponding to electrical activity of the tissue (e.g., electrocardiography data).

**[0095]** In some embodiments, a handle such as the handle shown in FIG. 7 may be coupled to the first jaw (102) and the second jaw (104). The handle may include one or more of a jaw control configured to control a spacing and/or angle between the first jaw (102) and the second jaw (104), electrode selection control, and pulse waveform control. In some embodiments, the first jaw (102) and the second jaw (104) may be coupled by a pivot (not shown) in which case, the jaws may form an angle with respect to each other. In some embodiments, the device (100) may include a spring (not shown) configured to bias the first jaw (102) and the second jaw (104) toward each other. In some embodiments, the first jaw (102) may be fixed relative to the handle while the second jaw (104) is configured to move relative to the first jaw (102).

**[0096]** FIG. 8 is a perspective view of a distal end of an ablation device (800) that may be structurally and/or functionally similar to the ablation device in FIG. 6. The ablation device (800) may include a body (830) having a lumen extending therethrough, a first jaw (810), and a second jaw (820). The first jaw (810) may include a first shaft (814) that extends through the lumen of the body (830). Likewise, the second jaw (820) may include a second shaft (824) that extends through the lumen of the body (830). In some embodiments, one or both of the jaws (810, 820) may move in a direction (840) relative to each other in order to modify a spacing between the first and second jaws (810, 820). In some embodiments, the jaws (810, 820) may be movable relative to the body (830) such that the jaws (810, 820) may advance and retract into and out of the body (830). Retraction of the jaws (810, 820) permits grasping a portion of tissue between the jaws. When the moveable jaw is released, the tissue may then be firmly held in place between the jaws. FIG. 8 shows a first jaw (810) and a second jaw (820) having a

generally elliptical (e.g., arcuate) shape. The jaws (810, 820) may be substantially rigid and parallel to each other.

**[0097]** A distal end of the first jaw (810) may include a set of first electrodes such as the two electrodes (812a, 812b) shown in FIG. 8. Likewise, a distal end of the second jaw (812) may include a set of second electrodes such as the two electrodes (822a, 822b) shown in FIG. 8. The pair of first electrodes (812a, 812b) and the pair of second electrodes (822a, 822b) may be arranged to be parallel, although they may be arcuate along their lengths. A set of tangent vectors to the elongate shape of each jaw may be defined, and a local longitudinal axis may, for example, pass through the center of the cross-section of either jaw such that the local longitudinal axis is parallel to the local tangent vector. Each of the first electrodes (812a, 812b) may be spaced apart from each other and each of the second electrodes (822a, 822b) may be spaced apart from each other. The local electrode cross-section may be generally perpendicular to the local longitudinal axis. The set of first electrodes (812) and the set of second electrodes (822) may be elongate electrodes. Some electrodes on opposite jaws may be directly across from each other, such that the normal to an electrode on one jaw points directly towards an electrode on the other jaw. In some embodiments, each electrode of the set of first electrodes (812) and the set of second electrodes (822) may be substantially rectangular. In other embodiments, each electrode of the set of first electrodes (812) and the set of second electrodes (822) may include a curved portion such as a generally arcuate shape or rounded edges. The electrodes may include a curvature that generally follows a curvature of its respective jaw.

**[0098]** The first electrodes (812a, 812b) may be disposed on a side of the first jaw (810) facing the second jaw (820). Similarly, the second electrodes (822a, 822b) may be disposed on a side of the second jaw (820) facing the first jaw (810). Each electrode of the first electrodes (812a, 812b) and the second electrodes (822a, 822b) may include an exposed portion in electrical contact with tissue during use. The exposed portion of each electrode of the first electrodes (812a, 812b) and the second electrodes (822a, 822b) may be flat or convex. Each electrode (812a, 812b, 822a, 822b) may have an insulated electrical lead associated therewith. The insulated electrical leads may be disposed in a corresponding shaft. In some embodiments, each electrode of the set of first electrodes (812) and the set of second electrodes (822) may be independently addressable. In some embodiments, the electrodes (812a, 812b, 822a, 822b) may

have a length of between about 1 cm and about 8 cm, a width of between about 1 mm and about 5 mm, and a height of between about 0.5 mm and about 3 mm. In some embodiments the electrodes (812a, 812b, 822a, 822b) may have a length to width ratio of at least about 3:1.

**[0099]** In some embodiments, an electrode of the set of first electrodes (812) may be configured as an anode and an electrode of the set of second electrodes (822) may be configured as a cathode. For example, the anode may be disposed directly across from the cathode within the cross-section orthogonal to the longitudinal axis. In some embodiments, a first electrode pairing may include electrodes (812a, 822a) directly across from each other on opposing jaws (810, 820) within the cross-section orthogonal to the longitudinal axis and a second electrode pairing may include electrodes (812b, 822b) directly across from each other on opposing jaws (810, 820) within the cross-section orthogonal to the longitudinal axis.

**[0100]** In other embodiments, the anode may be diagonal from the cathode such that the anode is laterally spaced apart from the cathode with respect to the longitudinal axis and/or does not intersect a line perpendicular to the cathode. In some embodiments, a first electrode pairing may include electrodes (812a, 822b) spaced apart laterally from each other on opposing jaws (810, 820) and a second electrode pairing may include electrodes (812b, 822a) spaced apart laterally from each other on opposing jaws (810, 820) with respect to the longitudinal axis. This combination of electrode pairing may reduce, if not eliminate, the risk of the electrodes electrically shorting in cases where tissue is incompletely grasped between the jaws and/or portions of the jaws touch each other.

**[0101]** In some embodiments, one electrode of one of the jaws may be configured as an anode while another electrode of the same jaw may be configured as a cathode. In some embodiments, a first electrode pairing may include electrodes (812a, 812b) adjacent to each other on the same jaw (810) and a second electrode pairing may include electrodes (822a, 822b) adjacent to each other on the same jaw (820).

**[0102]** Generally in the embodiments described herein, pulsed electric field ablation is delivered in order to generate irreversible electroporation in the tissue between the jaws. A pre-determined ablation sequence may include delivering ablation pulse waveforms sequentially over a pre-defined set of electrode pairings, for example first and second electrode pairings when

a set of two electrode pairings are configured. In some embodiments, the sequenced delivery may be triggered from a cardiac stimulator and/or pacing device. In some embodiments, the ablation pulse waveforms may be applied in a refractory period of the cardiac cycle to avoid disruption of the sinus rhythm of the heart, as described in more detail herein. One or more of the electrodes may be configured to receive signal data corresponding to electrical activity of the tissue (e.g., electrocardiography data).

**[0103]** In some embodiments, a handle such as the handle shown in FIG. 7 may be coupled to the first jaw (810) and the second jaw (820). The handle may include one or more of a jaw control configured to control a spacing and/or angle between the first jaw (810) and the second jaw (820), electrode selection control, and pulse waveform control. In some embodiments, the first jaw (810) and the second jaw (820) may be coupled by a pivot (not shown) in which case, the jaws may form an angle with respect to each other. In some embodiments, the device (800) may include a spring (not shown) configured to bias the first jaw (810) and the second jaw (820) toward each other. In some embodiments, the first jaw (810) may be fixed relative to the handle while the second jaw (820) is configured to move relative to the first jaw (810).

**[0104]** FIGS. 9A-9B are perspective views of a distal end of an ablation device (900) that may be structurally and/or functionally similar to the ablation device in FIG. 6. The ablation device (900) may include a first jaw (910) and a second jaw (920). In some embodiments, one or both of the jaws (910, 920) may move in a direction relative to each other in order to modify a spacing between the first and second jaws (910, 920). FIGS. 9A-9B show a first jaw (910) and a second jaw (920) having a generally elliptical (e.g., arcuate) shape. The jaws (910, 920) may be substantially rigid and parallel to each other. The jaws (910, 920) may collectively define a curved longitudinal axis (950).

**[0105]** A distal end of the first jaw (910) may include a set of first electrodes such as the three electrodes (912a, 912b, 912c) shown in FIGS. 9A-9B. Likewise, a distal end of the second jaw (912) may include a set of second electrodes such as the three electrodes (922a, 922b, 922c) shown in FIGS. 9A-9B. The trio of first electrodes (912a, 912b, 912c) and the trio of second electrodes (922a, 922b, 922c) orthogonal to the longitudinal axis may be arranged parallel to the curve of a long edge of the jaws.

**[0106]** Each of the first electrodes (912a, 912b, 912c) may be spaced apart from each other within the cross-section orthogonal to the longitudinal axis and each of the second electrodes (922a, 922b, 922c) may be spaced apart from each other within the cross-section orthogonal to the longitudinal axis. The set of first electrodes (912) and the set of second electrodes (922) may be elongate electrodes. In some embodiments, each electrode of the set of first electrodes (912) and the set of second electrodes (922) may be substantially rectangular. In other embodiments, each electrode of the set of first electrodes (912) and the set of second electrodes (922) may include a curved portion such as a generally arcuate shape or rounded edges. The electrodes may include a curvature such that generally each electrode follows the curvature of its respective jaw.

**[0107]** The first electrodes (912a, 912b, 912c) may be disposed on a side of the first jaw (910) facing the second jaw (920). Similarly, the second electrodes (922a, 922b, 922c) may be disposed on a side of the second jaw (920) facing the first jaw (910). Each electrode of the first electrodes (912a, 912b, 912c) and the second electrodes (922a, 922b, 922c) may include an exposed portion in electrical contact with tissue during use (FIG. 9B). The exposed portion of each electrode of the first electrodes (912a, 912b, 912c) and the second electrodes (922a, 922b, 922c) may be flat or convex. Each electrode (912a, 912b, 912c, 922a, 922b, 922c) may have an insulated electrical lead associated therewith. The insulated electrical leads may be disposed in a corresponding shaft. In some embodiments, each electrode of the set of first electrodes (912) and the set of second electrodes (922) may be independently addressable. In some embodiments, the electrodes (912a, 912b, 912c, 922a, 922b, 922c) may have a length of between about 1 cm and about 8 cm, a width of between about 1 mm and about 5 mm, and a height of between about 0.5 mm and about 3 mm. In some embodiments the electrodes (912a, 912b, 912c, 922a, 922b, 922c) may have a length to width ratio of at least about 3:1.

**[0108]** In some embodiments, an electrode of the set of first electrodes (912) may be configured as an anode and an electrode of the set of second electrodes (922) may be configured as a cathode. For example, the anode may be disposed directly across from the cathode. In some embodiments, a first electrode pairing may include electrodes (912a, 922a) directly across from each other on opposing jaws (910, 920), a second electrode pairing may include electrodes (912b, 922b) directly across from each other on opposing jaws (810, 820), and a third electrode

pairing may include electrodes (912c, 922c) directly across from each other on opposing jaws (910, 920).

**[0109]** In other embodiments, the anode may be diagonal from the cathode within the cross-section orthogonal to the longitudinal axis such that the anode is laterally spaced apart from the cathode with respect to the longitudinal axis and/or does not intersect a line perpendicular to the cathode. In some embodiments, a first electrode pairing may include electrodes (912a, 922b) spaced apart laterally from each other on opposing jaws (910, 920) with respect to the longitudinal axis, a second electrode pairing may include electrodes (912b, 922a) spaced apart laterally from each other on opposing jaws (910, 920) with respect to the longitudinal axis, a third electrode pairing may include electrodes (912b, 922c) spaced apart laterally from each other on opposing jaws (910, 920) with respect to the longitudinal axis, and a fourth electrode pairing may include electrodes (912c, 922b) spaced apart laterally from each other on opposing jaws (910, 920) with respect to the longitudinal axis.

**[0110]** In some embodiments, one electrode of one of the jaws may be configured as an anode while another electrode of the same jaw may be configured as a cathode. In some embodiments, a first electrode pairing may include electrodes (912a, 912b) adjacent to each other on the same first jaw (910), a second electrode pairing may include electrodes (912b, 912c) adjacent to each other on the same first jaw (910), a third electrode pairing may include electrodes (922a, 922b) adjacent to each other on the same second jaw (920), and a fourth electrode pairing may include electrodes (922b, 922c) adjacent to each other on the same second jaw (920).

**[0111]** A pre-determined ablation sequence may include delivering ablation pulse waveforms sequentially over a pre-defined set of electrode pairings. In some embodiments, the sequenced delivery may be triggered from a cardiac stimulator and/or pacing device. In some embodiments, the ablation pulse waveforms may be applied in a refractory period of the cardiac cycle to avoid disruption of the sinus rhythm of the heart, as described in more detail herein. One or more of the electrodes may be configured to receive signal data corresponding to electrical activity of the tissue (e.g., electrocardiography data).

**[0112]** FIG. 9B is a perspective view of the ablation device (900) coupled to tissue (930) after undergoing one or more ablation sequences as described herein. In FIG. 9B, at least a portion of

tissue (930) is held between the jaws (910, 920) of the device (900). In some embodiments, a tissue ablation zone (932) may have a width (940) that substantially corresponds to at least an end-to-end width between the electrodes (912a and 912c, 922a and 922c) of a jaw (910, 920). In some embodiments, the tissue (930) may comprise a portion of a pulmonary vein as shown, for example, in FIG. 10. Tissue between the jaws (910, 920) may be compressed relative to other portions of tissue (940).

**[0113]** In some embodiments, a handle such as the handle shown in FIG. 7 may be coupled to the first jaw (910) and the second jaw (920). The handle may include one or more of a jaw control configured to control a spacing and/or angle between the first jaw (910) and the second jaw (920), electrode selection control, and pulse waveform control. In some embodiments, the first jaw (910) and the second jaw (920) may be coupled by a pivot (not shown) in which case, the jaws may form an angle with respect to each other. In some embodiments, the device (900) may include a spring (not shown) configured to bias the first jaw (910) and the second jaw (920) toward each other. In some embodiments, the first jaw (910) may be fixed relative to the handle while the second jaw (920) is configured to move relative to the first jaw (910).

**[0114]** The electrodes as described may be composed of any suitable biocompatible conductive material including, but not limited to, one or more of silver, palladium, stainless steel, platinum, titanium, platinum-iridium alloys, gold, copper, nickel, combinations thereof, and the like. In some embodiments, the electrode materials may be plated, coated, and/or otherwise applied in an appropriately thick layer on top of a different substrate material. In some embodiments, electrode portions may be coupled using annealing, soldering, welding, crimping, lamination, combinations thereof, and the like. The jaws and body of the ablation devices disclosed may be composed of any suitable electrically insulating biocompatible material including polymers, ceramics, glasses, combinations thereof, and the like.

## II. Methods

**[0115]** Also described here are methods for ablating tissue (e.g., pulmonary vein) using the systems and devices described above. The ablation devices described herein may be used for ablation of cardiac features/structures identified to cause arrhythmia. The pulmonary vein may be connected to the left atrium of the heart. Generally, the methods described here include

introducing and disposing a device in contact with one or more pulmonary vein regions. A pulse waveform may be delivered by one or more electrodes of the device to ablate tissue. In some embodiments, a cardiac pacing signal may synchronize the delivered pulse waveforms with the cardiac cycle. Additionally or alternatively, the pulse waveforms may include a set of levels of a hierarchy. The tissue ablation thus performed may be delivered in synchrony with paced heartbeats. It should be appreciated that any of the ablation devices described herein may be used to ablate tissue using the methods discussed below as appropriate.

**[0116]** As a non-limiting example, in some embodiments, a system may include any of the devices described in the disclosure herein. FIG. 11 is a method (1100) for one embodiment of a tissue ablation process. In some embodiments, the voltage pulse waveforms described herein may be applied during a refractory period of the cardiac cycle to avoid disruption of the sinus rhythm of the heart. Generally, the method (1100) includes introduction of a device (e.g., ablation device, such as the ablation device (100), and/or any of the ablation devices (200, 300, 400, 500, 640, 700, 800, 900, 1000) into a chest cavity of a patient by any suitable means at step (1102). The chest of the patient may be surgically exposed to provide access to a desired ablation site, for example pulmonary vein in the region of the posterior left atrium. For example, the jaws/arms and body of the ablation device may enter the chest cavity at an oblique angle. It may be helpful to angle the jaws/arms in a manner that permits access to a posterior side of a patient's body (where the pulmonary veins may be located) through access from an anterior side of the patient's body. For example, a surgical excision may open and expose the chest cavity. In some embodiments, the ablation device may be advanced in a first configuration where the jaws/arms are closely spaced and/or in contact with each other to aid advancement of the ablation device towards a target tissue (e.g., pulmonary vein). For example, FIG. 10 is a perspective view of a distal end of an ablation device (1000) having a first jaw (1010) and a second jaw (1012) coupled to a pulmonary vein (1030) at a basal location (at the portion of tissue connecting the pulmonary vein to the left atrium) on a posterior side of the left atrium (1040). The ablation device (1000) may be transformed to contact tissue between the jaws/arms at step (1104). For example, the jaws of the ablation device (1000) may transition from a closed configuration to an open configuration to allow a portion of the pulmonary vein (1030) to be held between the jaws (1010, 1020). Saline may be introduced into the chest cavity to at least

partially surround the electrodes and create an electrically conductive environment for optimal delivery of current to tissue.

**[0117]** Returning to FIG. 11, at step 1106, the electrodes of the device may be configured in one or more anode/cathode subsets using, for example, the signal generator as described with respect to FIG. 6. For example, electrodes on opposing jaws and which are laterally spaced apart from each other with respect to the longitudinal axis may be configured in anode-cathode sets, as described with respect to FIGS. 8 and 9. This configuration may reduce the risk of shorting and may help generate uniform ablation across the compressed portion of tissue. In some embodiments, one or more electrodes may be configured to receive signal data corresponding to electrocardiography data. Electrocardiography data may be generated for display from the recorded signal data.

**[0118]** In some embodiments, a pacing signal may be generated for cardiac stimulation of the heart. The pacing signal may then be applied to the heart. For example, the heart may be electrically paced with a cardiac stimulator to ensure pacing capture to establish periodicity and predictability of the cardiac cycle. One or more of atrial and ventricular pacing may be applied. An indication of the pacing signal may be transmitted to a signal generator. A time window within the refractory period of the cardiac cycle may then be defined within which one or more voltage pulse waveforms may be delivered. In some embodiments, a refractory time window may follow a pacing signal. For example, a common refractory time window may lie between both atrial and ventricular refractory time windows.

**[0119]** A pulse waveform may be generated in synchronization with the pacing signal (1108). For example, a voltage pulse waveform may be applied in the common refractory time window. In some embodiments, the pulse waveform may be generated with a time offset with respect to the indication of the pacing signal. For example, the start of a refractory time window may be offset from the pacing signal by a time offset. The voltage pulse waveform(s) may be applied over a series of heartbeats over corresponding common refractory time windows.

**[0120]** In some embodiments, hierarchical voltage pulse waveforms having a nested structure and a hierarchy of time intervals as described herein may be useful for irreversible electroporation, providing control and selectivity in different tissue types. A pulse waveform

may be generated by a signal generator (e.g., the signal generator 610) and may include a set of levels in a hierarchy. A variety of hierarchical waveforms may be generated with a signal generator as disclosed herein. For example, the pulse waveform may include a first level of a hierarchy of the pulse waveform including a first set of pulses. Each pulse has a pulse time duration and a first time interval separating successive pulses. A second level of the hierarchy of the pulse waveform may include a plurality of first sets of pulses as a second set of pulses. A second time interval may separate successive first sets of pulses. The second time interval may be at least three times the duration of the first time interval. A third level of the hierarchy of the pulse waveform may include a plurality of second sets of pulses as a third set of pulses. A third time interval may separate successive second sets of pulses. The third time interval may be at least thirty times the duration of the second level time interval.

**[0121]** It is understood that while the examples herein identify separate monophasic and biphasic waveforms, it should be appreciated that combination waveforms, where some portions of the waveform hierarchy are monophasic while other portions are biphasic, may also be generated. A voltage pulse waveform having a hierarchical structure may be applied across different anode-cathode subsets (optionally with a time delay). As discussed above, one or more of the waveforms applied across the anode-cathode subsets may be applied during the refractory period of a cardiac cycle. The generated pulse waveform may be delivered to tissue. Accordingly, in the embodiments described herein, a contiguous, transmural zone of ablated tissue may be generated to electrically isolate the pulmonary vein from a main body of the left atrium.

**[0122]** In some embodiments, the pulse waveform may be delivered to pulmonary vein of a heart of a patient via one or more electrodes of a set of jaws of an ablation device. In other embodiments, voltage pulse waveforms as described herein may be selectively delivered to electrode subsets such as paired anode-cathode subsets for ablation and isolation of the pulmonary vein. For example, a first electrode of a first jaw may be configured as an anode and a second electrode of a second jaw may be configured as a cathode. These steps may be repeated for a desired number of pulmonary vein regions to be ablated.

## EXAMPLES

**[0123]** FIGS. 2A-2C depict a set of simulation results in the form of a shaded contour plot of the electric potential in a cross-sectional side view of an ablation device (200) that may be structurally and/or functionally similar to the ablation device in FIG. 6. The ablation device (200) includes a first jaw (202) and a second jaw (204). The first jaw (202) may include a first electrode (210) and a second electrode (220). The second jaw (204) may include a third electrode (230) and a fourth electrode (240). The first jaw (202) and the second jaw (204) may be spaced apart and substantially parallel, and configured to engage tissue (260) therebetween during use. The first jaw (202) and the second jaw (204) may be spaced apart by a third measure (262, 264, 266). The first electrode (210) and the second electrode (220) may be disposed on a side of the first jaw (202) facing the second jaw (204). Similarly, the third electrode (230) and the fourth electrode (240) may be disposed on a side of the second jaw (204) facing the first jaw (202). Each electrode (210, 220, 230, 240) may include an exposed portion in electrical contact with tissue (260) during use. The first electrode (210) and the second electrode (220) may be spaced apart by a first measure (203, 206). The third electrode (230) and the fourth electrode (240) may be spaced apart by a second measure (205, 207). The electrodes (210, 220, 230, 240) may be elongate electrodes as described herein. In some embodiments, each electrode (210, 220, 230, 240) may be independently addressable.

**[0124]** In some embodiments, the electrodes configured to deliver energy to tissue (260) may be adjacent electrodes on the same jaw. For example, a first electrode (210) may be configured as an anode and a second electrode (220) may be configured as a cathode. In FIGS. 2A-2C, the first jaw (202) may deliver about 200 V to tissue (260) between first electrode (210) and second electrode (220) to generate respective ablation zones (270, 272, 274) having an electric field strength of about 460 V/cm. The first measure (203, 206) may be 1 mm in FIG. 2A, 2 mm in FIG. 2B, and 3 mm in FIG. 2C. As shown in FIGS. 2A-2C, decreasing separation between electrodes (210, 220) may generate an ablation zone of lesser width and greater depth.

**[0125]** FIGS. 3A-3C depict a set of simulation results in the form of a shaded contour plot of the electric potential in a cross-sectional side view of an ablation device (300). The plots in FIGS. 3A-3C simulate higher voltages and greater separation between electrodes than the plots in FIGS. 2A-2C. The ablation device (300) includes a first jaw (302) and a second jaw (304).

The first jaw (302) may include a first electrode (310) and a second electrode (320). The second jaw (304) may include a third electrode (330) and a fourth electrode (340). The first jaw (302) and the second jaw (304) may be spaced apart and substantially parallel and configured to engage tissue (360) therebetween during use. The first jaw (302) and the second jaw (304) may be spaced apart by a third measure (360, 362, 364). The first electrode (310) and the second electrode (320) may be disposed on a side of the first jaw (302) facing the second jaw (304). Similarly, the third electrode (330) and the fourth electrode (340) may be disposed on a side of the second jaw (304) facing the first jaw (302). Each electrode (310, 320, 330, 340) may include an exposed portion in electrical contact with tissue (360) during use. The first electrode (310) and the second electrode (320) may be spaced apart by a first measure (303, 306, 308). The third electrode (330) and the fourth electrode (340) may be spaced apart by a second measure (305, 307, 309). The electrodes (310, 320, 330, 340) may be elongate electrodes as described herein. In some embodiments, each electrode (310, 320, 330, 340) may be independently addressable.

**[0126]** In some embodiments, the electrodes configured to deliver energy to tissue (360) may be adjacent electrodes on the same jaw. For example, a first electrode (310) may be configured as an anode and a second electrode (320) may be configured as a cathode. In FIGS. 3A-3C, the first jaw (302) may deliver about 300 V to tissue (360) between first electrode (310) and second electrode (320) to generate respective ablation zones (370, 372, 374) having an electric field strength of about 460 V/cm. The first measure (303, 306, 308) may be 3 mm in FIG. 3A, 4 mm in FIG. 3B, and 5 mm in FIG. 3C. As shown in FIGS. 3A-3C, decreasing separation between electrodes (310, 320) may generate an ablation zone of lesser width and greater depth. A separation of 5 mm in FIG. 3C may generate non-contiguous ablation zones (374).

**[0127]** FIGS. 4A-4E depict a set of simulation results in the form of a shaded contour plot of the electric potential in a cross-sectional side view of an ablation device (400). The plots in FIGS. 4A-4E generate electric fields using electrodes on opposing jaws rather than adjacent electrodes on the same jaw as shown in FIGS. 2A-3C. The ablation device (400) includes a first jaw (402) and a second jaw (404). The first jaw (402) may include a first electrode (410) and a second electrode (420). The second jaw (404) may include a third electrode (430) and a fourth electrode (440). The first jaw (402) and the second jaw (404) may be spaced apart and

substantially parallel and configured to engage tissue (460) therebetween during use. The first jaw (402) and the second jaw (404) may be spaced apart by a third measure (460, 462, 464, 466, 468). The first electrode (410) and the second electrode (420) may be disposed on a side of the first jaw (402) facing the second jaw (404). Similarly, the third electrode (430) and the fourth electrode (440) may be disposed on a side of the second jaw (404) facing the first jaw (402). Each electrode (410, 420, 430, 440) may include an exposed portion in electrical contact with tissue (460) during use. The first electrode (410) and the second electrode (420) may be spaced apart by a first measure (403). The third electrode (430) and the fourth electrode (440) may be spaced apart by a second measure (405). The electrodes (410, 420, 430, 440) may be elongate electrodes as described herein. In some embodiments, each electrode (410, 420, 430, 440) may be independently addressable.

**[0128]** In some embodiments, the electrodes configured to deliver energy to tissue (460) may be electrodes that directly oppose each other on different jaws within the cross-section orthogonal to the longitudinal axis. For example, a second electrode (420) may be configured as an anode and a fourth electrode (440) may be configured as a cathode. In FIG. 4A, the first jaw (402) may deliver about 200 V to tissue (460) between second electrode (420) and fourth electrode (440) to generate ablation zones (470) having an electric field strength of about 460 V/cm across a depth of the tissue (460) held by between the jaws (402, 404). In FIGS. 4B-4E, the first jaw (402) may deliver about 300 V to tissue (360) between second electrode (420) and fourth electrode (440) to generate respective ablation zones (470, 472, 474, 476, 478) having an electric field strength of about 460 V/cm. The third measure (460) may be 2 mm in FIG. 4A, third measure (462) may be 3 mm in FIG. 4B, third measure (464) may be 4 mm in FIG. 4C, third measure (466) may be 5 mm in FIG. 4D, and third measure (468) may be 6 mm in FIG. 4E. As shown in FIGS. 4B-4E, decreasing separation between electrodes (420, 440) may generate an ablation zone of greater intensity. A separation of 6 mm in FIG. 4E may generate non-contiguous ablation zones (478).

**[0129]** FIGS. 5A-5F depict a set of simulation results in the form of a shaded contour plot of the electric potential in a cross-sectional side view of an ablation device (500). The plots in FIGS. 5A-5F generate electric fields using electrodes disposed diagonally on opposing jaws rather than adjacent electrodes on the same jaw as shown in FIGS. 2A-3C. The ablation device

(500) includes a first jaw (502) and a second jaw (504). The first jaw (502) may include a first electrode (510) and a second electrode (520). The second jaw (504) may include a third electrode (530) and a fourth electrode (540). The first jaw (502) and the second jaw (504) may be spaced apart and substantially parallel and configured to engage tissue (560) therebetween during use. The first jaw (502) and the second jaw (504) may be spaced apart by a third measure (560, 562, 564, 566, 568, 569). The first electrode (510) and the second electrode (520) may be disposed on a side of the first jaw (502) facing the second jaw (504). Similarly, the third electrode (530) and the fourth electrode (540) may be disposed on a side of the second jaw (504) facing the first jaw (502). Each electrode (510, 520, 530, 540) may include an exposed portion in electrical contact with tissue (560) during use. The first electrode (510) and the second electrode (520) may be spaced apart by a first measure (503). The third electrode (530) and the fourth electrode (540) may be spaced apart by a second measure (505). The electrodes (510, 520, 530, 540) may be elongate electrodes as described herein. In some embodiments, each electrode (510, 520, 530, 540) may be independently addressable.

**[0130]** In some embodiments, the electrodes configured to deliver energy to tissue (560) may be electrodes that are laterally spaced apart and adjacent on opposing different jaws. For example, a second electrode (520) may be configured as an anode and a third electrode (530) may be configured as a cathode. This anode-cathode configuration of the electrodes reduces the risk of electrical shorting since the anode and cathode will not contact each other even if the jaws are brought into contact with each other. In FIG. 5A, the first jaw (502) may deliver about 200 V to tissue (560) between second electrode (520) and third electrode (540) to generate ablation zone (560) having an electric field strength of about 460 V/cm across a depth of the tissue (460) held between the jaws (502, 504). In FIGS. 5B-5C, the first jaw (502) may deliver about 300 V to tissue (560) between second electrode (520) and third electrode (530) to generate respective ablation zones (572, 574) having an electric field strength of about 460 V/cm. In FIGS. 5D-5E, the first jaw (502) may deliver about 400 V to tissue (560) between second electrode (520) and third electrode (530) to generate respective ablation zones (576, 578) having an electric field strength of about 460 V/cm. In FIG. 5F, the first jaw (502) may deliver about 500 V to tissue (560) between second electrode (520) and third electrode (530) to generate ablation zone (579) having an electric field strength of about 460 V/cm. Thus, by increasing the applied voltage, deeper ablation zones may be produced which may be useful when the tissue

between the clamps is relatively thicker. As a set of non-limiting examples, the third measure (560) may be 2 mm in FIG. 5A, third measure (562) may be 4 mm in FIG. 5B, third measure (564) may be 5 mm in FIG. 5C, third measure (566) may be 5 mm in FIG. 5D, third measure (568) may be 6 mm in FIG. 5E, and third measure (569) may be 6 mm in FIG. 5F.

### Pulse Waveform

**[0131]** Disclosed herein are methods, systems and apparatuses for the selective and rapid application of pulsed electric fields/waveforms to effect tissue ablation with irreversible electroporation. The pulse waveform(s) as disclosed herein are usable with any of the systems (600), devices (e.g., 200, 300, 400, 500, 640, 700, 800, 900, 1000), and methods (e.g., 1100) described herein. Some embodiments are directed to pulsed high voltage waveforms together with a sequenced delivery scheme for delivering energy to tissue via sets of electrodes. In some embodiments, peak electric field values may be reduced and/or minimized while at the same time sufficiently large electric field magnitudes may be maintained in regions where tissue ablation is desired. This also reduces the likelihood of excessive tissue damage or the generation of electrical arcing, and locally high temperature increases. In some embodiments, a system useful for irreversible electroporation includes a signal generator and a processor capable of being configured to apply pulsed voltage waveforms to a selected plurality or a subset of electrodes of an ablation device. In some embodiments, the processor is configured to control inputs whereby selected pairs of anode-cathode subsets of electrodes may be sequentially triggered based on a pre-determined sequence, and in one embodiment the sequenced delivery may be triggered from a cardiac stimulator and/or pacing device. In some embodiments, the ablation pulse waveforms are applied in a refractory period of the cardiac cycle to avoid disruption of the sinus rhythm of the heart. One example method of enforcing this is to electrically pace the heart with a cardiac stimulator and ensure pacing capture to establish periodicity and predictability of the cardiac cycle, and then to define a time window well within the refractory period of this periodic cycle within which the ablation waveform is delivered.

**[0132]** In some embodiments, the pulsed voltage waveforms disclosed herein are hierarchical in organization and have a nested structure. In some embodiments, the pulsed waveform includes hierarchical groupings of pulses with a variety of associated timescales. Furthermore, the associated timescales and pulse widths, and the numbers of pulses and hierarchical

groupings, may be selected to satisfy one or more of a set of Diophantine inequalities involving the frequency of cardiac pacing.

**[0133]** Pulsed waveforms for electroporation energy delivery as disclosed herein may enhance the safety, efficiency and effectiveness of the energy delivery by reducing the electric field threshold associated with irreversible electroporation, yielding more effective ablative lesions with reduced total energy delivered. This in turn may broaden the areas of clinical application of electroporation including therapeutic treatment of a variety of cardiac arrhythmias.

**[0134]** FIG. 12 illustrates a pulsed voltage waveform in the form of a sequence of rectangular double pulses, with each pulse, such as the pulse (1200) being associated with a pulse width or duration. The pulse width/duration may be about 0.5 microseconds, about 1 microsecond, about 5 microseconds, about 10 microseconds, about 25 microseconds, about 50 microseconds, about 100 microseconds, about 125 microseconds, about 140 microseconds, about 150 microseconds, including all values and sub-ranges in between. The pulsed waveform of FIG. 12 illustrates a set of monophasic pulses where the polarities of all the pulses are the same (all positive in FIG. 12, as measured from a zero baseline). In some embodiments, such as for irreversible electroporation applications, the height of each pulse (1200) or the voltage amplitude of the pulse (1200) may be in the range of about 300 volts, about 1,000 volts, or about 5,000 volts, including all values and sub ranges in between. As illustrated in FIG. 12, the pulse (1200) is separated from a neighboring pulse by a time interval (1202), also sometimes referred to as a first time interval. The first time interval may be about 10 microseconds, about 50 microseconds, about 100 microseconds, about 200 microseconds, about 500 microseconds, about 800 microseconds, about 1 millisecond including all values and sub ranges in between, in order to generate irreversible electroporation.

**[0135]** FIG. 13 introduces a pulse waveform with the structure of a hierarchy of nested pulses. FIG. 13 shows a series of monophasic pulses such as pulse (1300) with pulse width/pulse time duration  $w$ , separated by a time interval (also sometimes referred to as a first time interval) such as (1302) of duration  $t_1$  between successive pulses, a number  $m_1$  of which are arranged to form a group of pulses (1310) (also sometimes referred to as a first set of pulses). Furthermore, the waveform has a number  $m_2$  of such groups of pulses (also sometimes referred to as a second set of pulses) separated by a time interval (1312) (also sometimes referred to as a second time

interval) of duration  $t_2$  between successive groups. The collection of  $m_2$  such pulse groups, marked by (1320) in FIG. 13, constitutes the next level of the hierarchy, which may be referred to as a packet and/or as a third set of pulses. The pulse width and the time interval  $t_1$  between pulses may both be in the range of microseconds to hundreds of microseconds, including all values and sub ranges in between. In some embodiments, the time interval  $t_2$  may be at least three times larger than the time interval  $t_1$ . In some embodiments, the ratio  $t_2/t_1$  may be in the range between about 3 and about 300, including all values and sub-ranges in between.

**[0136]** FIG. 14 further elaborates the structure of a nested pulse hierarchy waveform. In this figure, a series of  $m_1$  pulses (individual pulses not shown) form a group of pulses (1400) (e.g., a first set of pulses). A series of  $m_2$  such groups separated by an inter-group time interval (1410) of duration  $t_2$  (e.g., a second time interval) between one group and the next form a packet 132 (e.g., a second set of pulses). A series of  $m_3$  such packets separated by time intervals (1412) of duration  $t_3$  (e.g., a third time interval) between one packet and the next form the next level in the hierarchy, a super-packet labeled (1420) (e.g., a third set of pulses) in the figure. In some embodiments, the time interval  $t_3$  may be at least about thirty times larger than the time interval  $t_2$ . In some embodiments, the time interval  $t_3$  may be at least fifty times larger than the time interval  $t_2$ . In some embodiments, the ratio  $t_3/t_2$  may be in the range between about 30 and about 800, including all values and sub-ranges in between. The amplitude of the individual voltage pulses in the pulse hierarchy may be anywhere in the range from 300 volts to 7,000 volts or higher, including all values and sub ranges in between.

**[0137]** FIG. 15 provides an example of a biphasic waveform sequence with a hierarchical structure. In the example shown in the figure, biphasic pulses such as (1500) have a positive voltage portion as well as a negative voltage portion to complete one cycle of the pulse. There is a time delay (1502) (e.g., a first time interval) between adjacent cycles of duration  $t_1$ , and  $m_1$  such cycles form a group of pulses (1510) (e.g., a first set of pulses). A series of  $m_2$  such groups separated by an inter-group time interval (1512) (e.g., a second time interval) of duration  $t_2$  between one group and the next form a packet (1520) (e.g., a second set of pulses). The figure also shows a second packet (1530), with a time delay (1532) (e.g., a third time interval) of duration  $t_3$  between the packets. Just as for monophasic pulses, higher levels of the hierarchical structure may be formed as well. The amplitude of each pulse or the voltage amplitude of the

biphasic pulse may be anywhere in the range from 300 volts to 7,000 volts or higher, including all values and sub ranges in between. The pulse width/pulse time duration may be in the range from nanoseconds or even sub-nanoseconds to tens of microseconds, while the delays  $t_1$  may be in the range from zero to several microseconds. The inter-group time interval  $t_2$  may be at least ten times larger than the pulse width. In some embodiments, the time interval  $t_3$  may be at least about twenty times larger than the time interval  $t_2$ . In some embodiments, the time interval  $t_3$  may be at least fifty times larger than the time interval  $t_2$ .

**[0138]** Embodiments disclosed herein include waveforms structured as hierarchical waveforms that include waveform elements/pulses at various levels of the hierarchy. The individual pulses such as (1300) in FIG. 13 includes the first level of the hierarchy, and have an associated pulse time duration and a first time interval between successive pulses. A set of pulses, or elements of the first level structure, form a second level of the hierarchy such as the group of pulses/second set of pulses (1310) in FIG. 13. Among other parameters, associated with the waveform are parameters such as a total time duration of the second set of pulses (not shown), a total number of first level elements/first set of pulses, and second time intervals between successive first level elements that describe the second level structure/second set of pulses. In some embodiments, the total time duration of the second set of pulses may be between about 20 microseconds and about 10 milliseconds, including all values and subranges in between. A set of groups, second set of pulses, or elements of the second level structure, form a third level of the hierarchy such as the packet of groups/third set of pulses (1320) in FIG. 13. Among other parameters, there is a total time duration of the third set of pulses (not shown), a total number of second level elements/second set of pulses, and third time intervals between successive second level elements that describe the third level structure/third set of pulses. In some embodiments, the total time duration of the third set of pulses may be between about 60 microseconds and about 200 milliseconds, including all values and sub ranges in between. The generally iterative or nested structure of the waveforms may continue to a higher plurality of levels, such as ten levels of structure, or more.

**[0139]** In some embodiments, hierarchical waveforms with a nested structure and hierarchy of time intervals as described herein are useful for irreversible electroporation ablation energy delivery, providing a good degree of control and selectivity for applications in different tissue

types. A variety of hierarchical waveforms may be generated with a suitable pulse generator. It is understood that while the examples herein identify separate monophasic and biphasic waveforms for clarity, it should be noted that combination waveforms, where some portions of the waveform hierarchy are monophasic while other portions are biphasic, may also be generated/implemented.

**[0140]** In some embodiments, the ablation pulse waveforms described herein are applied during the refractory period of the cardiac cycle to avoid disruption of the sinus rhythm of the heart. In some embodiments, a method of treatment includes electrically pacing the heart with a cardiac stimulator to ensure pacing capture to establish periodicity and predictability of the cardiac cycle, and then defining a time window within the refractory period of the cardiac cycle within which one or more pulsed ablation waveforms may be delivered. FIG. 16 illustrates an example where both atrial and ventricular pacing is applied (for instance, with pacing leads or catheters situated in the right atrium and right ventricle respectively). With time represented on the horizontal axis, FIG. 16 illustrates a series of ventricular pacing signals such as (1600) and (1610), and a series of atrial pacing signals (1620, 1630), along with a series of ECG waveforms (1640, 1642) that are driven by the pacing signals. As indicated in FIG. 16 by the thick arrows, there is an atrial refractory time window (1622) and a ventricular refractory time window (1602) that respectively follow the atrial pacing signal (1622) and the ventricular pacing signal (1600). As shown in FIG. 16, a common refractory time window (1650) of duration  $T_r$  may be defined that lies within both atrial and ventricular refractory time windows (1622, 1602). In some embodiments, the electroporation ablation waveform(s) may be applied in this common refractory time window (1650). The start of this refractory time window (1622) is offset from the pacing signal (1600) by a time offset (1604) as indicated in FIG. 16. The time offset (1604) may be smaller than about 25 milliseconds, in some embodiments. At the next heartbeat, a similarly defined common refractory time window (1652) is the next time window available for application of the ablation waveform(s). In this manner, the ablation waveform(s) may be applied over a series of heartbeats, at each heartbeat remaining within the common refractory time window. In one embodiment, each packet of pulses as defined above in the pulse waveform hierarchy may be applied over a heartbeat, so that a series of packets is applied over a series of heartbeats, for a given electrode set.

**[0141]** It should be understood that the examples and illustrations in this disclosure serve exemplary purposes and departures and variations such as the shape and size of the jaws and electrodes, number of electrodes, and so on may be built and deployed according to the teachings herein without departing from the scope of this invention.

**[0142]** As used herein, the terms “about” and/or “approximately” when used in conjunction with numerical values and/or ranges generally refer to those numerical values and/or ranges near to a recited numerical value and/or range. In some instances, the terms “about” and “approximately” may mean within  $\pm 10\%$  of the recited value. For example, in some instances, “about 100 [units]” may mean within  $\pm 10\%$  of 100 (e.g., from 90 to 110). The terms “about” and “approximately” may be used interchangeably.

**[0143]** Some embodiments described herein relate to a computer storage product with a non-transitory computer-readable medium (also may be referred to as a non-transitory processor-readable medium) having instructions or computer code thereon for performing various computer-implemented operations. The computer-readable medium (or processor-readable medium) is non-transitory in the sense that it does not include transitory propagating signals per se (e.g., a propagating electromagnetic wave carrying information on a transmission medium such as space or a cable). The media and computer code (also may be referred to as code or algorithm) may be those designed and constructed for the specific purpose or purposes. Examples of non-transitory computer-readable media include, but are not limited to, magnetic storage media such as hard disks, floppy disks, and magnetic tape; optical storage media such as Compact Disc/Digital Video Discs (CD/DVDs), Compact Disc-Read Only Memories (CD-ROMs), and holographic devices; magneto-optical storage media such as optical disks; carrier wave signal processing modules; and hardware devices that are specially configured to store and execute program code, such as Application-Specific Integrated Circuits (ASICs), Programmable Logic Devices (PLDs), Read-Only Memory (ROM) and Random-Access Memory (RAM) devices. Other embodiments described herein relate to a computer program product, which may include, for example, the instructions and/or computer code disclosed herein.

**[0144]** The systems, devices, and/or methods described herein may be performed by software (executed on hardware), hardware, or a combination thereof. Hardware modules may include, for example, a general-purpose processor (or microprocessor or microcontroller), a field

programmable gate array (FPGA), and/or an application specific integrated circuit (ASIC). Software modules (executed on hardware) may be expressed in a variety of software languages (e.g., computer code), including C, C++, Java®, Ruby, Visual Basic®, and/or other object-oriented, procedural, or other programming language and development tools. Examples of computer code include, but are not limited to, micro-code or micro-instructions, machine instructions, such as produced by a compiler, code used to produce a web service, and files containing higher-level instructions that are executed by a computer using an interpreter. Additional examples of computer code include, but are not limited to, control signals, encrypted code, and compressed code.

**[0145]** The specific examples and descriptions herein are exemplary in nature and embodiments may be developed by those skilled in the art based on the material taught herein without departing from the scope of the present invention, which is limited only by the attached claims.

## CLAIMS

We Claim:

1. An apparatus, comprising:

a first jaw including a plurality of first electrodes; and

a second jaw including a plurality of second electrodes, the first jaw and the second jaw being substantially rigid, elongate, and collectively defining a longitudinal axis, the first jaw and the second jaw further configured to engage tissue therebetween during use,

each electrode of the plurality of first electrodes having, within a cross-section of the first jaw and the second jaw that is orthogonal to the longitudinal axis, a width that is less than a length of that electrode, the plurality of first electrodes spaced apart laterally with respect to the longitudinal axis,

each electrode of the plurality of second electrodes having, within the cross-section orthogonal to the longitudinal axis, a width that is less than a length of that electrode, the plurality of second electrodes spaced apart laterally with respect to the longitudinal axis,

the plurality of first electrodes and the plurality of second electrodes including electrode pairs configured to deliver ablative energy to the tissue in response to receiving a pulse waveform having an amplitude of at least about 200 Volts, at least one electrode pair including an electrode of the plurality of first electrodes and an electrode of the plurality of second electrodes disposed diagonally across from one another within the cross-section orthogonal to the longitudinal axis.

2. The apparatus of claim 1, wherein the longitudinal axis has one or more of a straight portion and curved portion.

3. The apparatus of claim 1, wherein, for each electrode pair, the electrode of the plurality of first electrodes is configured as an anode and the electrode of the plurality of second electrodes is configured as a cathode.

4. The apparatus of claim 3, wherein the anode is spaced apart laterally from the cathode in the cross-section orthogonal to the longitudinal axis.
5. The apparatus of claim 1, wherein at least two electrodes of the plurality of first electrodes are spaced apart by a first measure, and the first jaw and the second jaw are spaced apart by a second measure when engaged with the tissue therebetween during use, and a ratio of the second measure to the first measure is between about 0.1:1 and about 12:1.
6. The apparatus of claim 1, wherein a distance between a midpoint of at least two electrodes of the plurality of first electrodes in the cross-section orthogonal to the longitudinal axis is between about 1 mm and about 10 mm.
7. The apparatus of claim 1, wherein any two adjacent electrodes of the plurality of first electrodes are spaced apart by a first measure of between about 0.5 mm and about 10 mm and any two adjacent electrodes of the plurality of second electrodes are spaced apart by a second measure of between about 0.5 mm and about 10 mm.
8. The apparatus of claim 1, wherein any two adjacent electrodes of the plurality of first electrodes are spaced apart by a first measure and any two adjacent electrodes of the plurality of second electrodes are spaced apart by a second measure, wherein a ratio of the first measure to the second measure is between about 0.05:1 and about 20:1.
9. The apparatus of claim 1, wherein any two adjacent electrodes of the plurality of first electrodes are spaced apart by a first measure and any two adjacent electrodes of the plurality of second electrodes are spaced apart by a second measure, wherein a ratio of the width of any electrode of the plurality of first electrodes to the width of any electrode of the plurality of second electrodes to the first measure is between about 0.01:1 and about 10:1.
10. The apparatus of claim 1, wherein each electrode of the plurality of first electrodes and the plurality of second electrodes has a length of between about 10 mm and about 120 mm.
11. The apparatus of claim 1, wherein the first and second jaws are configured to transition between a first configuration for positioning the first and second jaws through or

around a body cavity, organ system, or anatomical structure and a second configuration for engaging the tissue.

12. The apparatus of claim 11, wherein the first and second jaws are spaced apart by a spacing distance in the second configuration.
13. The apparatus of claim 1, wherein a cross-sectional shape of each electrode of the plurality of first electrodes and a cross-sectional shape of each electrode of the plurality of second electrodes are substantially rectangular.
14. The apparatus of claim 1, wherein each electrode of the plurality of first electrodes and the plurality of second electrodes includes a curved portion.
15. The apparatus of claim 14, wherein the curved portion has a radius of curvature of about 1 cm or larger.
16. The apparatus of claim 14, wherein the curved portion has a J shape.
17. The apparatus of claim 1, wherein each electrode of the plurality of first electrodes and the plurality of second electrodes includes an exposed portion in electrical contact with the tissue during use.
18. The apparatus of claim 17, wherein the exposed portion of each electrode of the plurality of first electrodes and the plurality of second electrodes is flat or convex.
19. The apparatus of claim 1, wherein the first and second jaws extend parallel to one another.
20. The apparatus of claim 1, further comprising:  
  
a pulse generator comprising a controller, the pulse generator coupled to each electrode of the plurality of first electrodes and the plurality of second electrodes, the controller comprising a processor and memory, and the pulse generator configured to:

generate the pulse waveform;

configure a first set of electrodes including at least an electrode of the plurality of first electrodes and an electrode of the plurality of second electrodes for pulse waveform delivery; and

deliver the pulse waveform to the first set of electrodes.

21. The apparatus of claim 20, wherein the pulse generator is further configured to:

configure a second set of electrodes including at least an electrode of the plurality of first electrodes and an electrode of the plurality of second electrodes for receiving electrical activity of tissue; and

receive signal data corresponding to electrical activity of the tissue using the second set of electrodes; and

generate electrocardiography data using the signal data.

22. The apparatus of claim 1, further comprising a handle coupled to the first jaw and the second jaw.

23. The apparatus of claims 22, wherein the handle includes one or more of a jaw control, electrode selection control, and pulse waveform control.

24. The apparatus of claim 1, further comprising a pivot coupling the first jaw to the second jaw.

25. The apparatus of claim 1, further comprising a spring configured to bias the first and second jaws closed.

26. The apparatus of claim 1, further comprising one or more lead wires coupled to the plurality of first electrodes and the plurality of second electrodes.

27. The apparatus of claim 1, wherein each electrode of the plurality of first electrodes and the plurality of second electrodes are independently addressable.

28. An apparatus, comprising:

a first jaw including a first electrode and a second electrode;

a second jaw including a third electrode and a fourth electrode, the first jaw and the second jaw being substantially rigid, elongate, and collectively defining a longitudinal axis, the first jaw and the second jaw further configured to engage tissue therebetween during use, wherein, within a cross-section of the first jaw and the second jaw that is orthogonal to the longitudinal axis, the first electrode is disposed directly across the third electrode, the second electrode is disposed directly across the fourth electrode, and the first electrode is disposed diagonally across from the fourth electrode; and

a processor operably coupled to the first jaw and the second jaw, the processor configured to, during use:

configure the first electrode as an anode and the fourth electrode as a cathode; and

deliver pulsed electric field ablative energy via the first electrode and the fourth electrode.

29. The apparatus of claim 28, wherein the longitudinal axis has one or more of a straight portion and a curved portion.

30. The apparatus of claim 28, wherein the first electrode and the second electrode are spaced apart by a first measure of between about 0.5 mm and about 10 mm, and the third electrode and the fourth electrode are spaced apart by a second measure of between about 0.5 mm and about 10 mm.

31. The apparatus of claim 28 wherein the first electrode and the second electrode are spaced apart by a first measure and the third electrode and the fourth electrode are spaced apart by a second measure, wherein a ratio of the first measure to the second measure is between about 0.05:1 and about 20:1.

32. The apparatus of claim 28, wherein the first electrode and the second electrode are spaced apart by a first measure, wherein a ratio of a width of the first electrode to the first measure is between about 0.01:1 and about 10:1.

33. The apparatus of claim 28, wherein the first, second, third, and fourth electrodes each have a length of between about 10 mm and about 120 mm.

34. The apparatus of claim 28, wherein the first and second jaws are configured to transition between a first configuration for positioning the first and second jaws through or around a body cavity, organ system, or anatomical structure and a second configuration for engaging the tissue.

35. The apparatus of claim 34, wherein the first and second jaws are spaced apart by a spacing distance in the second configuration.

36. The apparatus of claim 28, wherein a cross-section of the first, second, third, and fourth electrodes are substantially rectangular.

37. The apparatus of claim 28, wherein the first, second, third, and fourth electrodes include a curved portion.

38. The apparatus of claim 36, wherein the curved portion has a radius of curvature of about 1 cm or larger.

39. The apparatus of claim 36, wherein the curved portion has a J shape.

40. The apparatus of claim 38, wherein the first, second, third, and fourth electrodes include an exposed portion in electrical contact with the tissue during use.

41. The apparatus of claim 39, wherein the exposed portion of each of the electrodes is flat or convex.

42. The apparatus of claims 28, wherein the first and second jaws extend parallel to one another.

43. The apparatus of claims 28, further comprising:

a pulse generator comprising a controller, the pulse generator coupled to the first, second, third, and fourth electrodes, the controller comprising a processor and memory, and the pulse generator configured to:

generate a pulse waveform of at least about 200 Volts;

configure a first set of electrodes including one or more of the first, second, third, and fourth electrodes for pulse waveform delivery; and

deliver the pulse waveform to the first set of electrodes.

44. The apparatus of claims 28, wherein the generator is further configured to:

configure a second set of electrodes including one or more of the first, second, third, and fourth electrodes for receiving electrical activity of tissue;

receive signal data corresponding to electrical activity of the tissue using the second set of electrodes; and

generate electrocardiography data using the signal data.

45. The apparatus of claim 28, further comprising a handle coupled to the first jaw and the second jaw.

46. The apparatus of claims 28, wherein the handle includes one or more of a jaw control, electrode selection control, and pulse waveform control.

47. The apparatus of claim 28, further comprising a pivot coupling the first jaw to the second jaw.

48. The apparatus of claim 28, further comprising a spring configured to bias the first and second jaws closed.

49. The apparatus of claim 28, further comprising one or more lead wires coupled to the first, second, third, and fourth electrodes.

50. The apparatus of claim 28, wherein each of the first electrode, second electrode, third electrode, and fourth electrode are independently addressable.

51. A method of ablating tissue via irreversible electroporation comprising:

clamping the tissue between a first jaw and a second jaw of an apparatus, the first jaw including a plurality of first electrodes, the second jaw including a plurality of second electrodes, the first jaw and the second jaw being substantially rigid, elongate, and collectively defining a longitudinal axis,

each electrode of the plurality of first electrodes having, within a cross-section of the first jaw and the second jaw that is orthogonal to the longitudinal axis, a width that is less than a length of that electrode, the plurality of first electrodes spaced apart laterally with respect to the longitudinal axis,

each electrode of the plurality of second electrodes having, within the cross-section orthogonal to the longitudinal axis, a width that is less than a length of that electrode, the plurality of second electrodes spaced apart laterally with respect to the longitudinal axis;

configuring an electrode of the plurality of first electrodes as an anode;

configuring an electrode of the plurality of second electrodes as a cathode, the anode and the cathode being, within the cross-section orthogonal to the longitudinal axis, disposed diagonally across and spaced apart laterally from other another;

delivering ablative energy to the tissue via the anode and the cathode.

52. The method of claim 51, wherein the longitudinal axis has one or more of a straight portion and curved portion.

53. The method of 51, wherein clamping the tissue comprises transitioning the first and second jaws between a first configuration for advancing the apparatus and a second configuration for clamping the tissue.

54. The method of claim 51, wherein the tissue is a region of an atrial base of a pulmonary vein.

55. The method of claim 51, the pulse waveform including:

a first level of a hierarchy including a first set of pulses, each pulse having a pulse time duration and a first time interval separating successive pulses;

a second level of the hierarchy including a plurality of first sets of pulses as a second set of pulses and a second time interval separating successive first sets of pulses, the second time interval being at least three times the duration of the first time interval; and

a third level of the hierarchy including a plurality of second sets of pulses as a third set of pulses and a third time interval separating successive second sets of pulses, the third time interval being at least thirty times the duration of the second level time interval.

56. The method of 51, further comprising:

receiving signal data corresponding to electrical activity of the tissue using one or more electrodes of the plurality of first electrodes and the plurality of second electrodes; and

generating electrocardiography data using the signal data.

57. The method of 51, further comprising positioning the first and second jaws through or around a body cavity, organ system, or anatomical structure.

58. The method of claim 49, wherein each electrode of the plurality of first electrodes and the plurality of second electrodes are independently addressable.

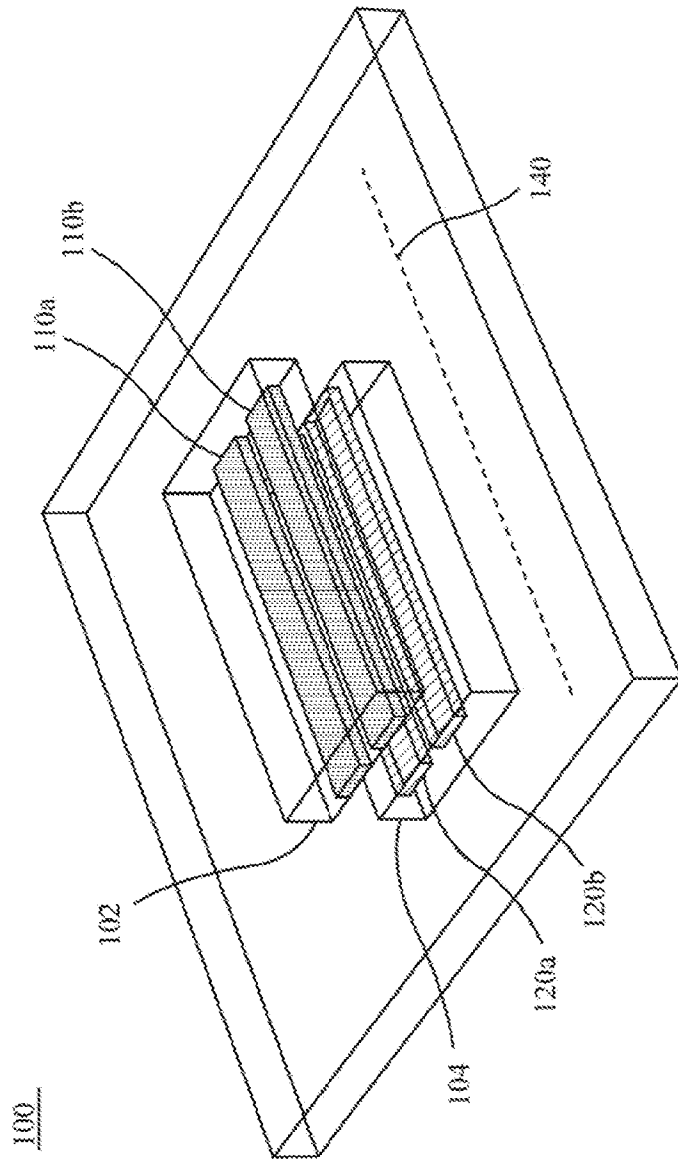


FIG. 1A

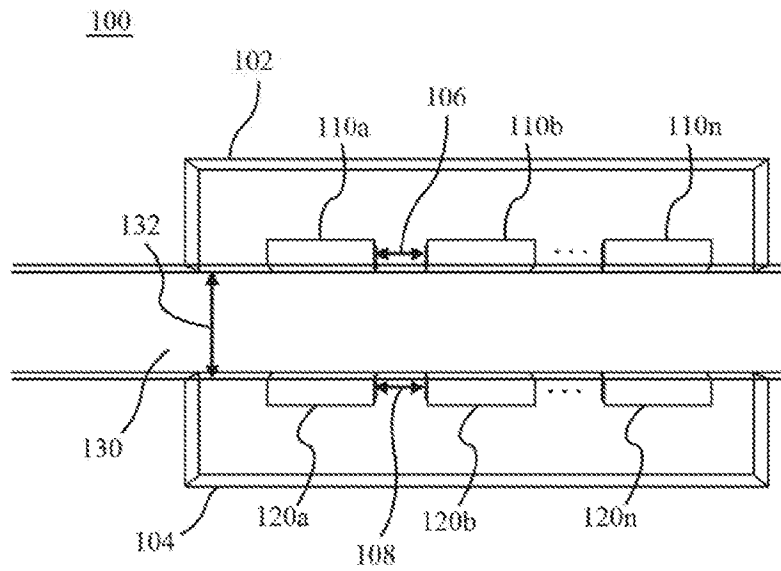


FIG. 1B

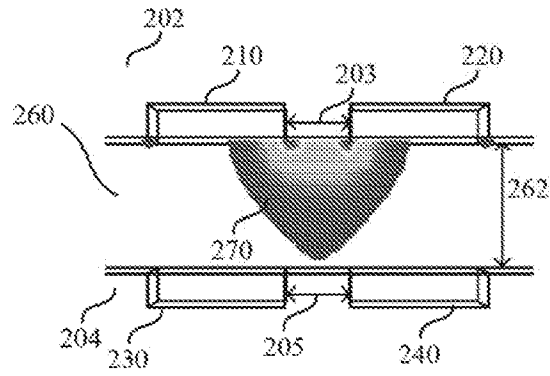


FIG. 2A

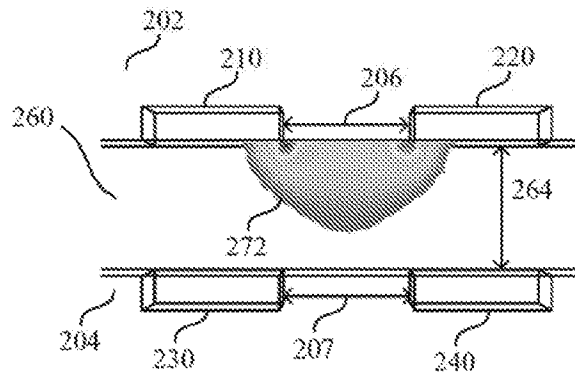


FIG. 2B

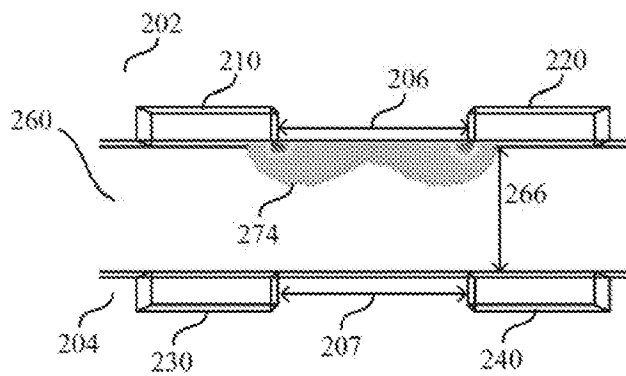


FIG. 2C

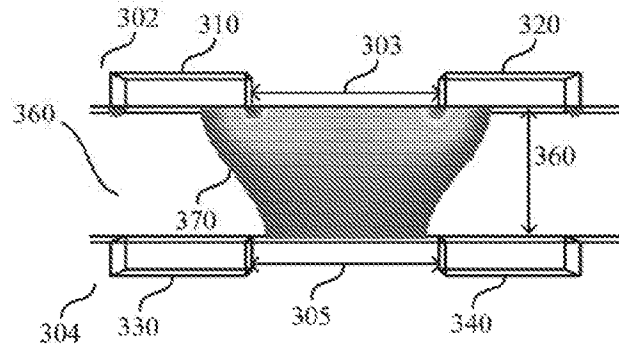


FIG. 3A

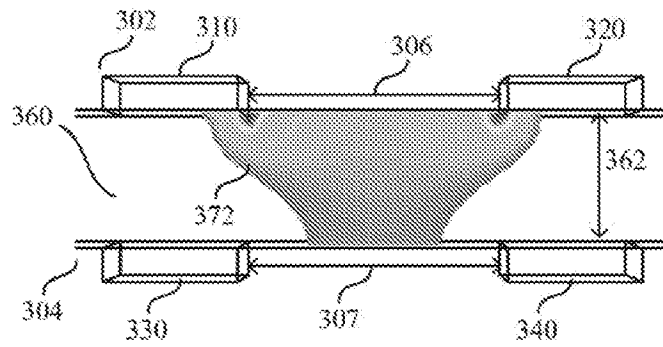


FIG. 3B

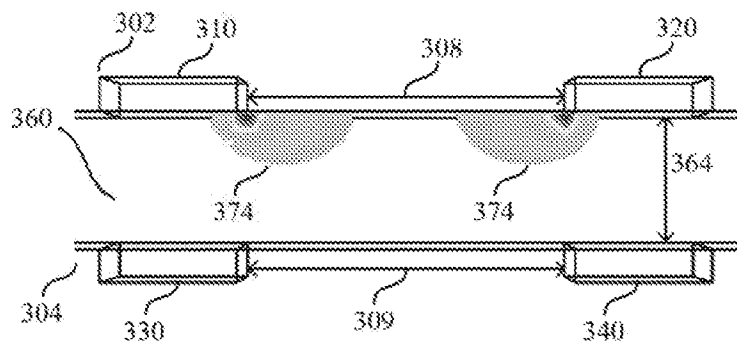


FIG. 3C

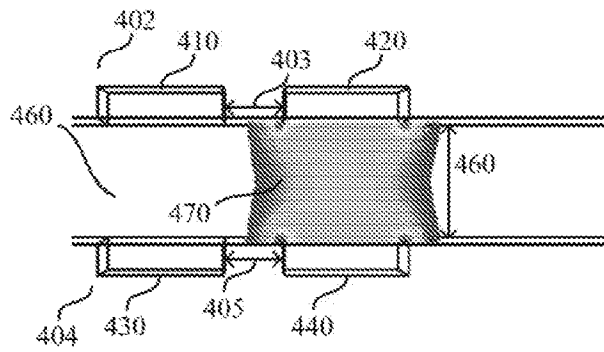


FIG. 4A

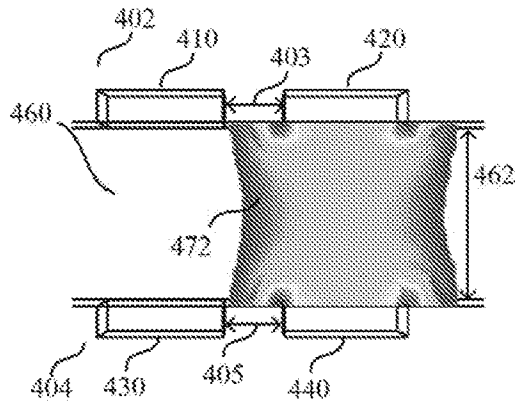


FIG. 4B

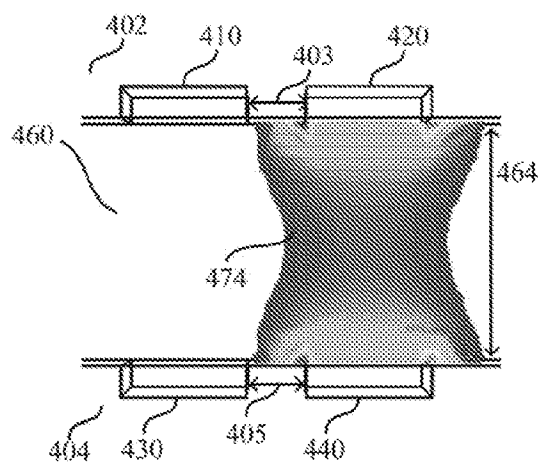


FIG. 4C

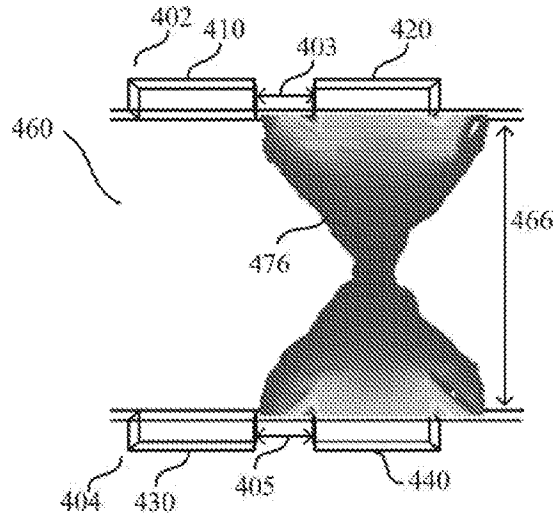


FIG. 4D

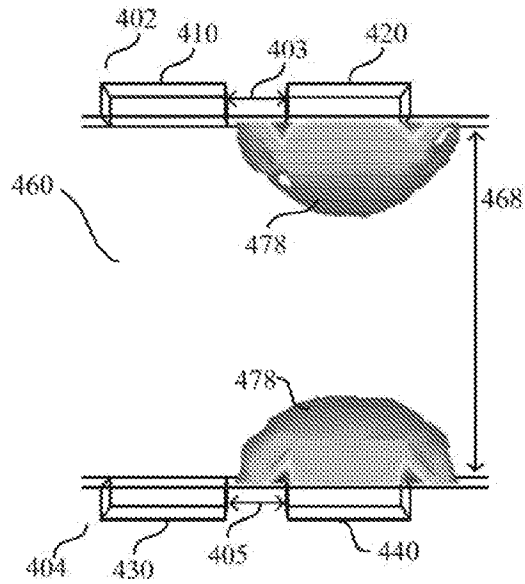


FIG. 4E

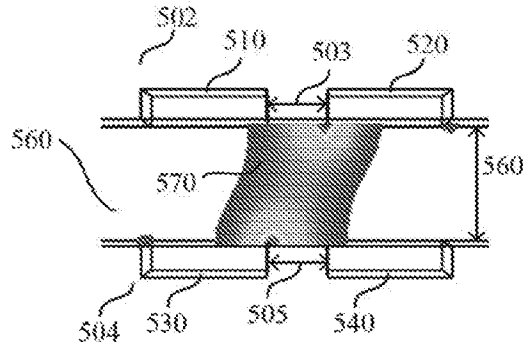


FIG. 5A

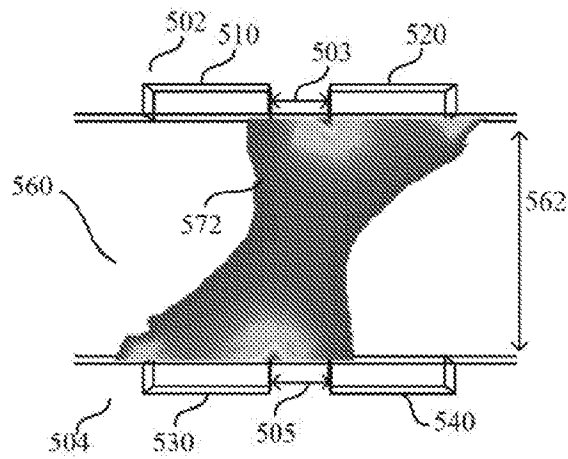


FIG. 5B

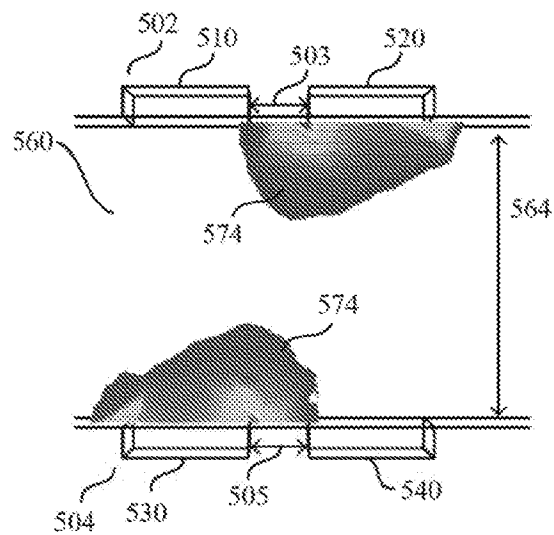


FIG. 5C

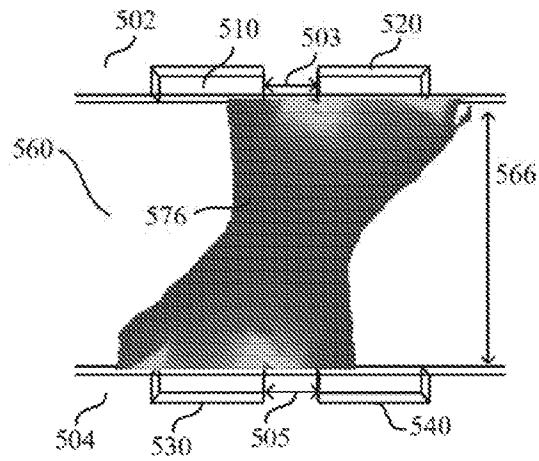


FIG. 5D

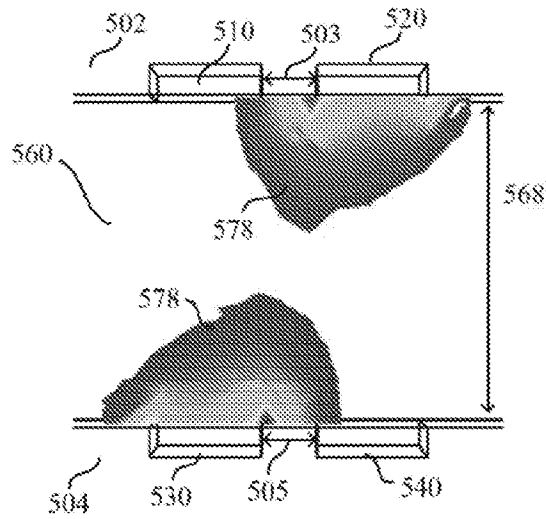


FIG. 5E

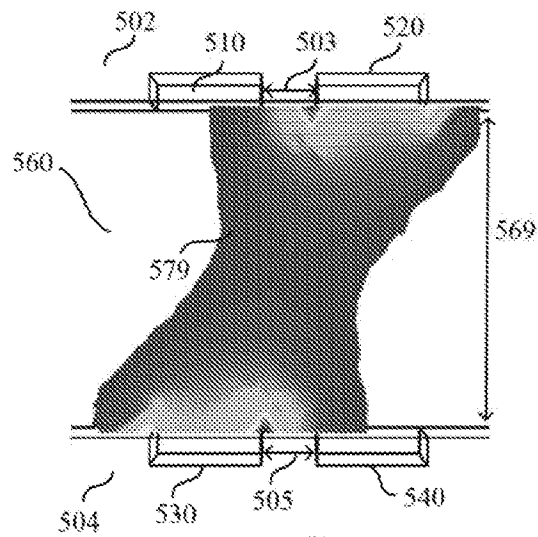


FIG. 5F

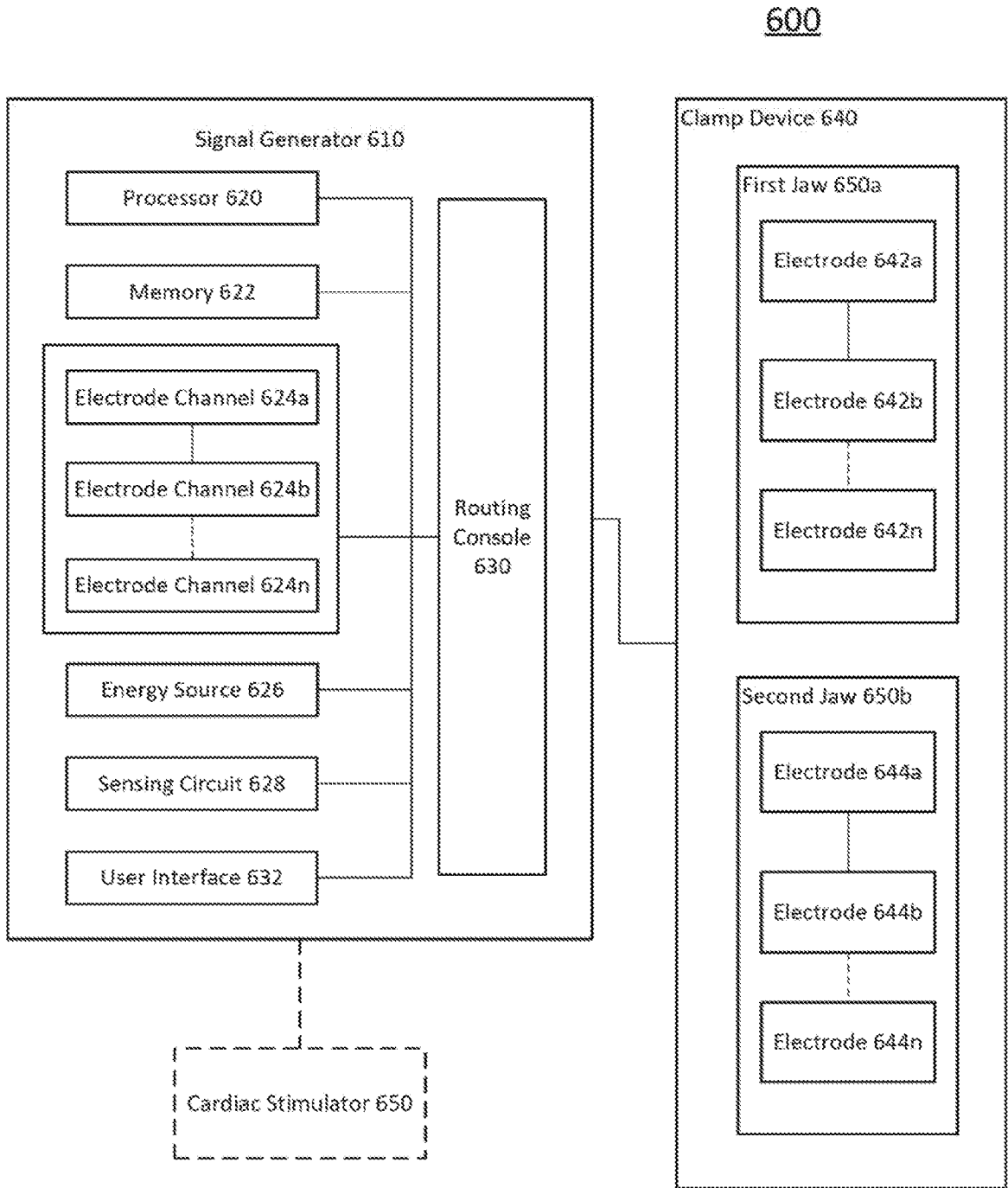


FIG. 6

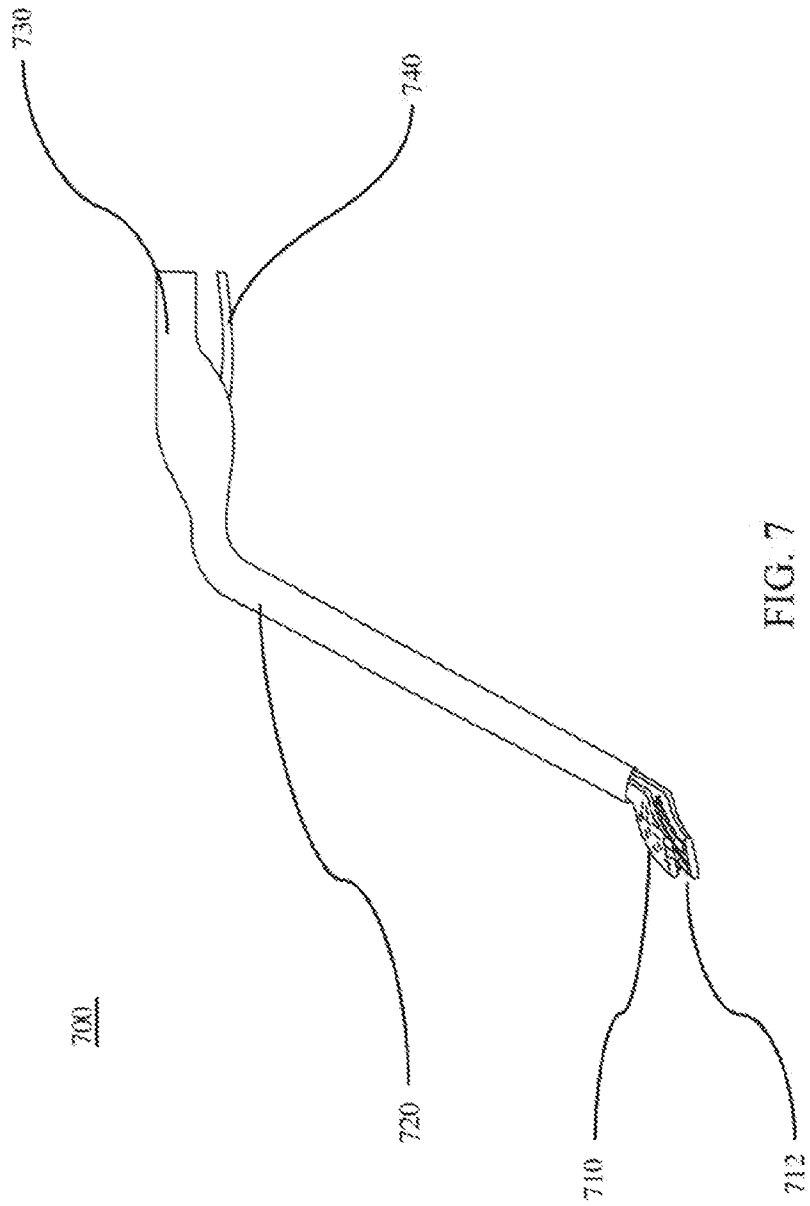


FIG. 7

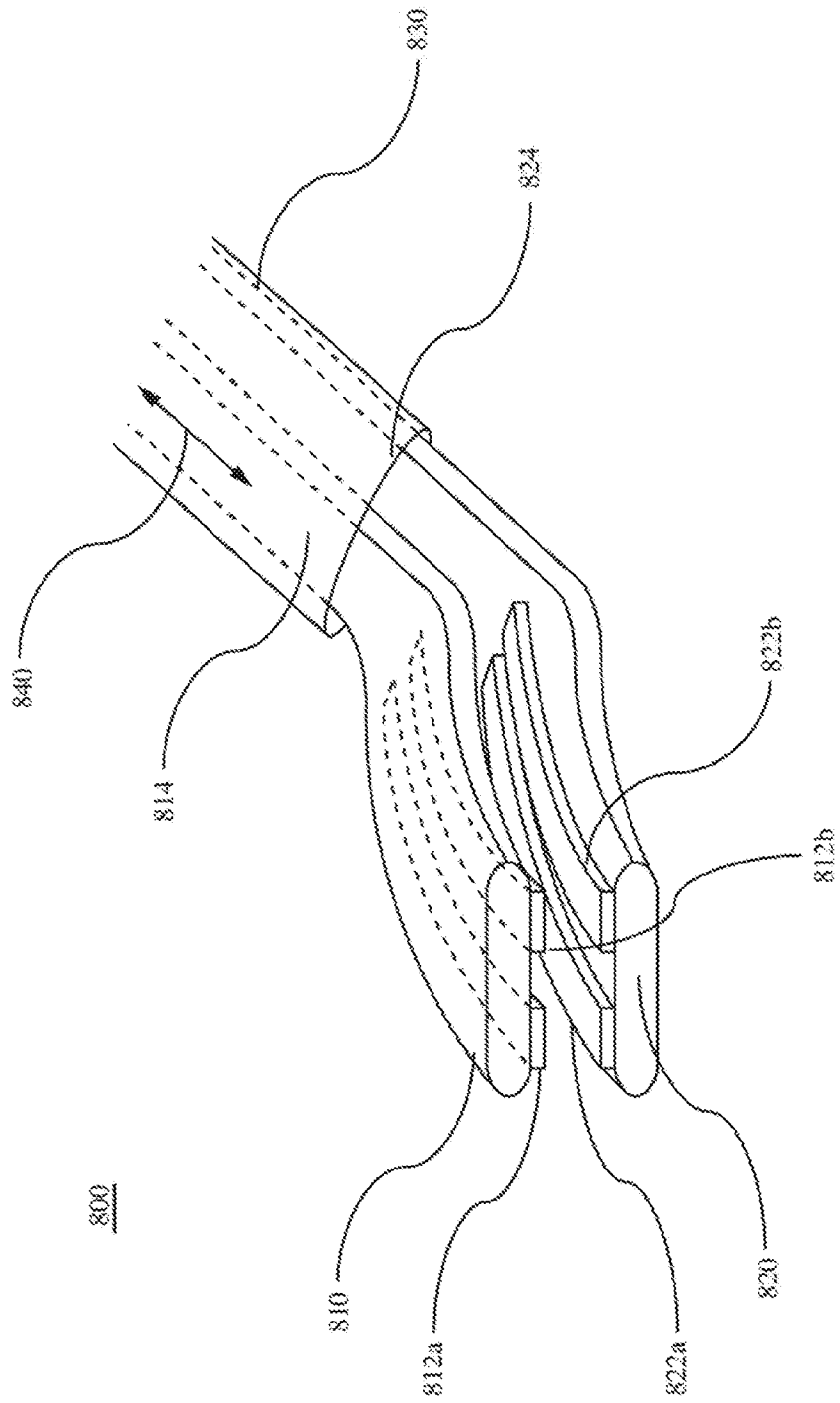


FIG. 8

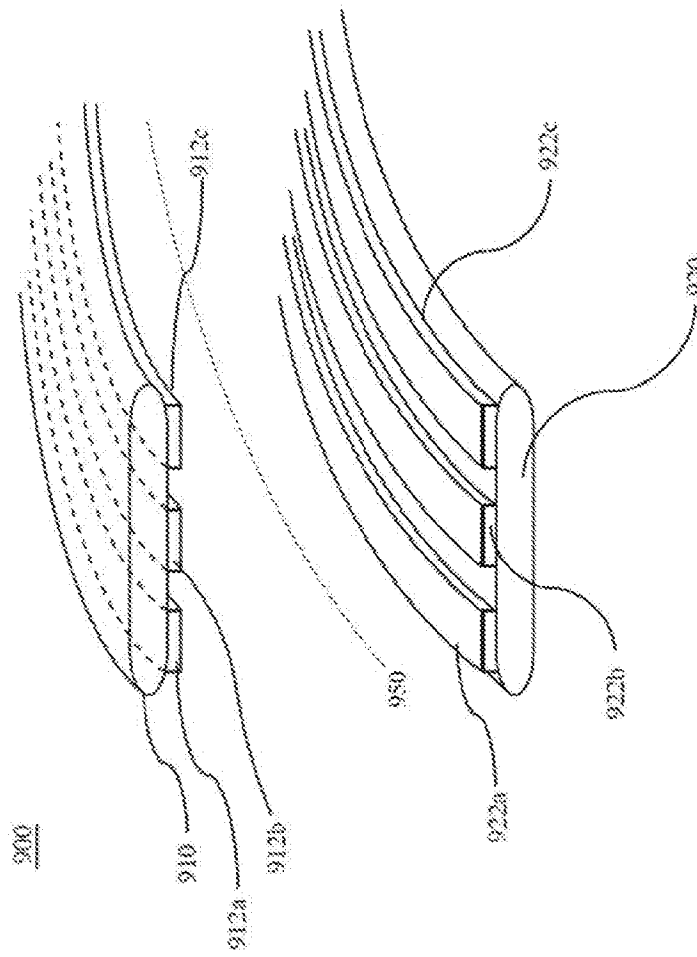


FIG. 9A

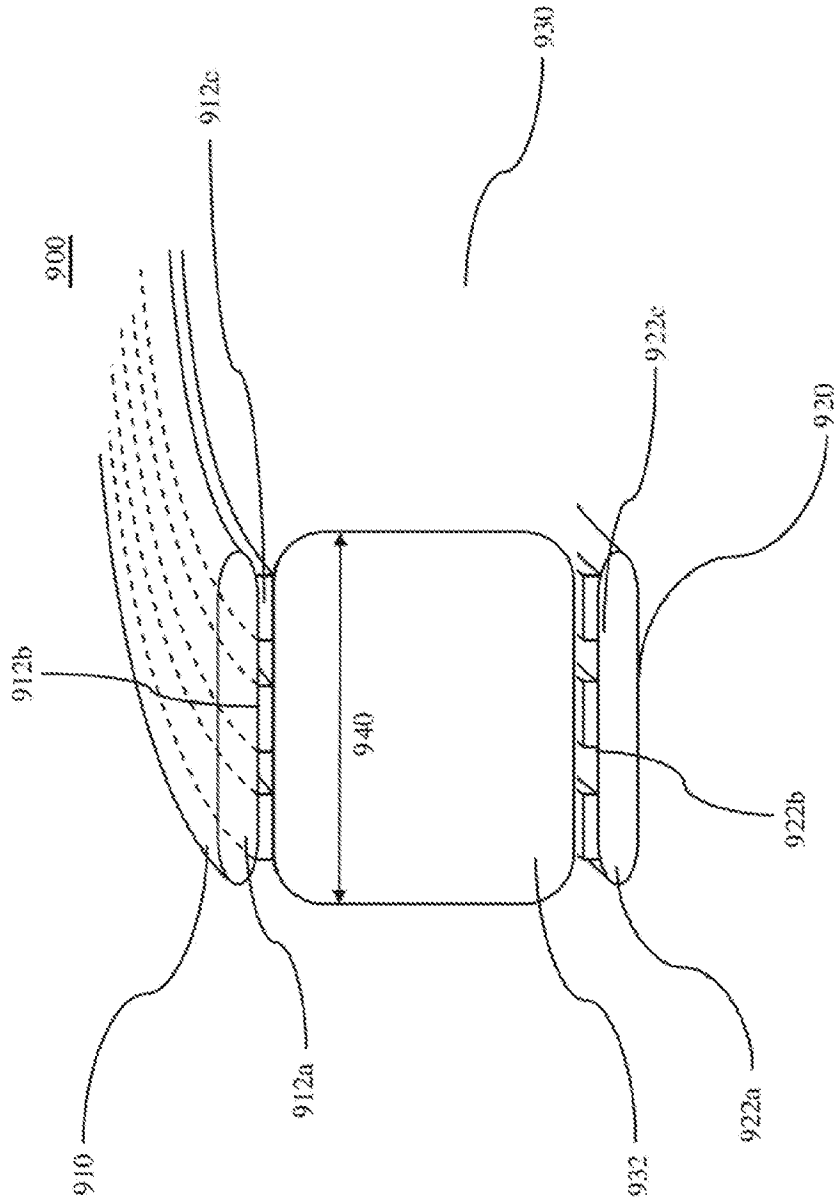


FIG. 9B

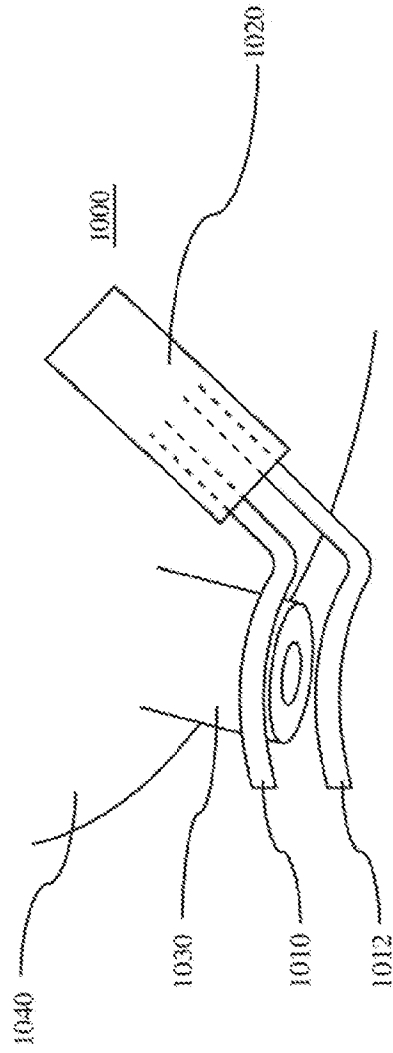


FIG. 10

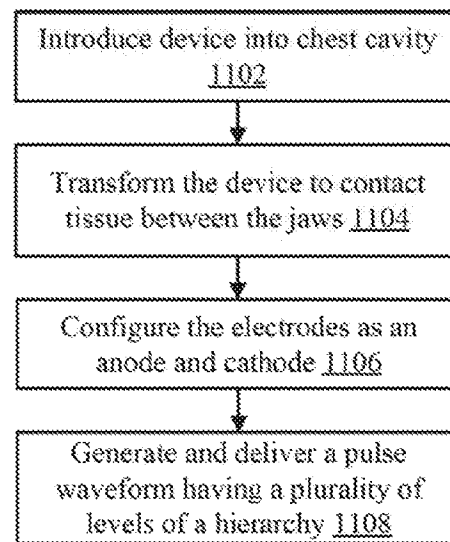
1100

FIG. 11

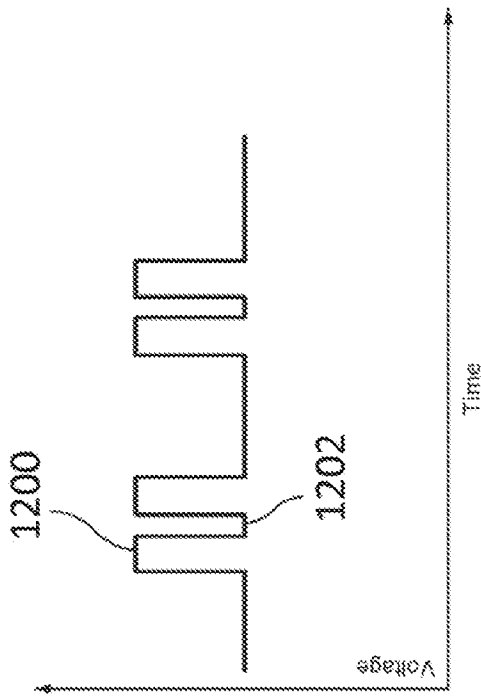


FIG. 12

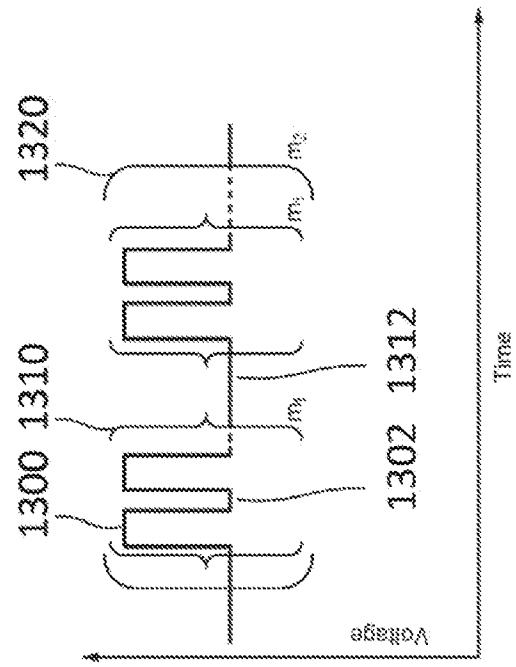


FIG. 13

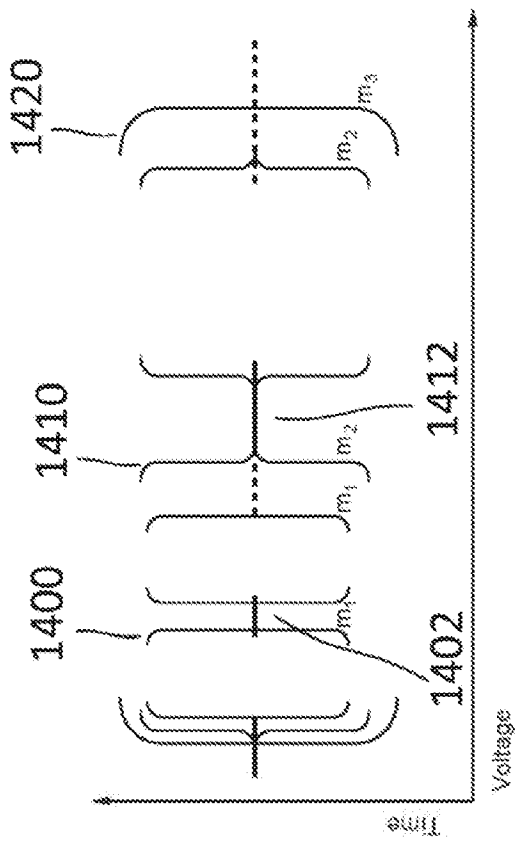


FIG. 14

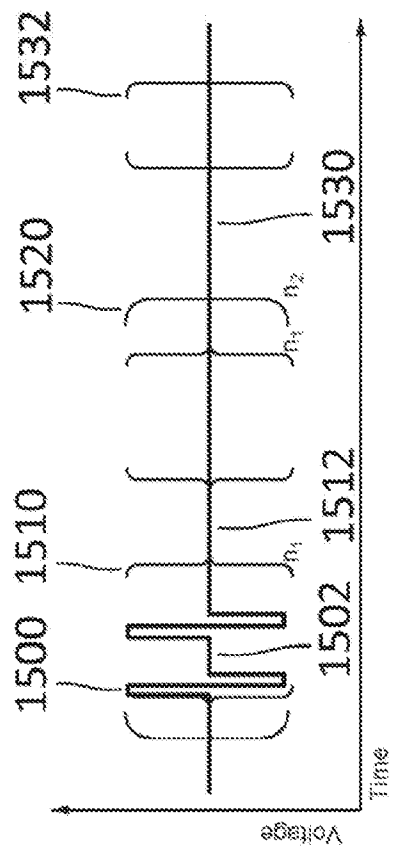


FIG. 15

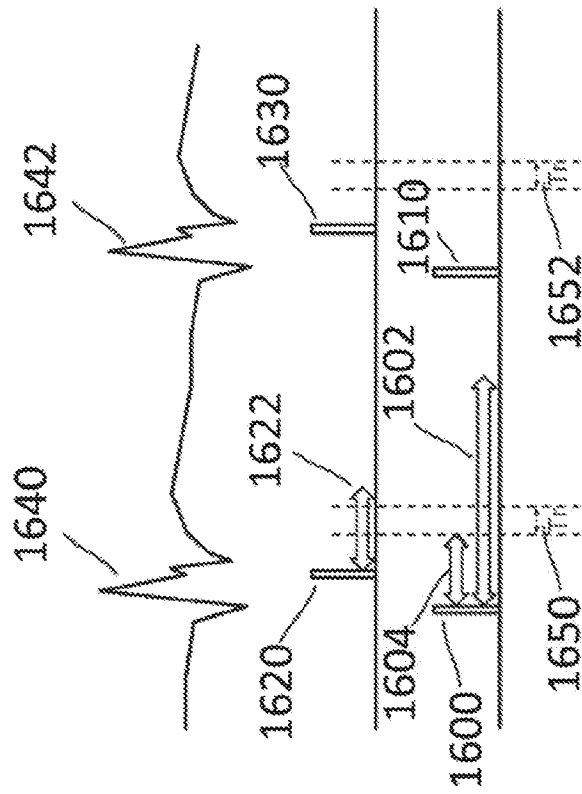


FIG. 16

INTERNATIONAL SEARCH REPORT

International application No  
PCT/US2019/028943

A. CLASSIFICATION OF SUBJECT MATTER  
 INV. A61B18/14  
 ADD. A61B18/00            A61B17/28            A61B17/29

According to International Patent Classification (IPC) or to both national classification and IPC

B. FIELDS SEARCHED

Minimum documentation searched (classification system followed by classification symbols)  
 A61B

Documentation searched other than minimum documentation to the extent that such documents are included in the fields searched

Electronic data base consulted during the international search (name of data base and, where practicable, search terms used)  
 EPO-Internal, WPI Data

C. DOCUMENTS CONSIDERED TO BE RELEVANT

Category*	Citation of document, with indication, where appropriate, of the relevant passages	Relevant to claim No.
X	WO 99/56650 A1 (PERFECT SURGICAL TECH INC [US]) 11 November 1999 (1999-11-11)	1-13, 17-20, 22-36, 40-43, 45-50
Y	abstract; figures 2E, 8, 10A-10C page 2, line 18 - page 6, line 4 page 7, line 21 - line 29 page 8, line 33 - page 9, line 9 page 11, line 10 - line 23 page 12, line 15 - line 34 page 13, line 1 - line 33 -----	14-16, 21, 37-39,44
Y	WO 99/59486 A2 (NEW ENGLAND MEDICAL CENTER INC [US]) 25 November 1999 (1999-11-25)	14-16, 37-39
A	abstract page 9, line 17 - line 19; figure 7A -----	1-13, 17-36, 40-50
	----- -/--	

Further documents are listed in the continuation of Box C.

See patent family annex.

\* Special categories of cited documents :

- "A" document defining the general state of the art which is not considered to be of particular relevance
- "E" earlier application or patent but published on or after the international filing date
- "L" document which may throw doubts on priority claim(s) or which is cited to establish the publication date of another citation or other special reason (as specified)
- "O" document referring to an oral disclosure, use, exhibition or other means
- "P" document published prior to the international filing date but later than the priority date claimed

- "T" later document published after the international filing date or priority date and not in conflict with the application but cited to understand the principle or theory underlying the invention
- "X" document of particular relevance; the claimed invention cannot be considered novel or cannot be considered to involve an inventive step when the document is taken alone
- "Y" document of particular relevance; the claimed invention cannot be considered to involve an inventive step when the document is combined with one or more other such documents, such combination being obvious to a person skilled in the art
- "&" document member of the same patent family

Date of the actual completion of the international search  5 September 2019	Date of mailing of the international search report  17/09/2019
---	--

Name and mailing address of the ISA/ European Patent Office, P.B. 5818 Patentlaan 2 NL - 2280 HV Rijswijk Tel. (+31-70) 340-2040, Fax: (+31-70) 340-3016	Authorized officer  Lorenz, Larissa
--	---

## INTERNATIONAL SEARCH REPORT

International application No  
PCT/US2019/028943

C(Continuation). DOCUMENTS CONSIDERED TO BE RELEVANT		
Category*	Citation of document, with indication, where appropriate, of the relevant passages	Relevant to claim No.
Y	WO 2010/014480 A1 (MEDTRONIC INC [US]; BONNER MATTHEW D [US] ET AL.) 4 February 2010 (2010-02-04)	21,44
A	abstract page 8, line 8 - line 19	1-20, 22-43, 45-50
A	----- WO 2015/192018 A1 (IOWA APPROACH INC [US]) 17 December 2015 (2015-12-17) abstract; figures 7, 12, 15 paragraphs [1058], [1064]	1-50
A	----- US 5 810 762 A (HOFMANN GUNTER A [US]) 22 September 1998 (1998-09-22) abstract; figures 2, 3 column 3, line 21 - column 4, line 24 -----	1-50

# INTERNATIONAL SEARCH REPORT

Information on patent family members

International application No PCT/US2019/028943
---

Patent document cited in search report	Publication date	Patent family member(s)	Publication date
WO 9956650	A1	11-11-1999	AT 353597 T 15-03-2007
			AU 3779099 A 23-11-1999
			DE 69935139 T2 31-10-2007
			EP 1079745 A1 07-03-2001
			ES 2283112 T3 16-10-2007
			JP 2002513623 A 14-05-2002
			US 6030384 A 29-02-2000
			US 6162220 A 19-12-2000
			WO 9956650 A1 11-11-1999
			-----
WO 9959486	A2	25-11-1999	AU 4007299 A 06-12-1999
			DE 69926625 T2 08-06-2006
			EP 1079747 A2 07-03-2001
			EP 1593349 A1 09-11-2005
			US 2002052602 A1 02-05-2002
			US 2002058934 A1 16-05-2002
			US 2004087941 A1 06-05-2004
			US 2004204706 A1 14-10-2004
			US 2006217699 A1 28-09-2006
			WO 9959486 A2 25-11-1999
-----			
WO 2010014480	A1	04-02-2010	EP 2317951 A1 11-05-2011
			US 2010023004 A1 28-01-2010
			WO 2010014480 A1 04-02-2010
-----			
WO 2015192018	A1	17-12-2015	EP 3154464 A1 19-04-2017
			US 2017065330 A1 09-03-2017
			WO 2015192018 A1 17-12-2015
-----			
US 5810762	A	22-09-1998	NONE
-----			

# INTERNATIONAL SEARCH REPORT

International application No.  
PCT/US2019/028943

## Box No. II Observations where certain claims were found unsearchable (Continuation of item 2 of first sheet)

This international search report has not been established in respect of certain claims under Article 17(2)(a) for the following reasons:

1.  Claims Nos.: **51-58**  
because they relate to subject matter not required to be searched by this Authority, namely:  
**see FURTHER INFORMATION sheet PCT/ISA/210**
  
2.  Claims Nos.:  
because they relate to parts of the international application that do not comply with the prescribed requirements to such an extent that no meaningful international search can be carried out, specifically:
  
3.  Claims Nos.:  
because they are dependent claims and are not drafted in accordance with the second and third sentences of Rule 6.4(a).

## Box No. III Observations where unity of invention is lacking (Continuation of item 3 of first sheet)

This International Searching Authority found multiple inventions in this international application, as follows:

1.  As all required additional search fees were timely paid by the applicant, this international search report covers all searchable claims.
  
2.  As all searchable claims could be searched without effort justifying an additional fees, this Authority did not invite payment of additional fees.
  
3.  As only some of the required additional search fees were timely paid by the applicant, this international search report covers only those claims for which fees were paid, specifically claims Nos.:
  
4.  No required additional search fees were timely paid by the applicant. Consequently, this international search report is restricted to the invention first mentioned in the claims; it is covered by claims Nos.:

### Remark on Protest

- The additional search fees were accompanied by the applicant's protest and, where applicable, the payment of a protest fee.
- The additional search fees were accompanied by the applicant's protest but the applicable protest fee was not paid within the time limit specified in the invitation.
- No protest accompanied the payment of additional search fees.

**FURTHER INFORMATION CONTINUED FROM PCT/ISA/ 210**

Continuation of Box II.1

Claims Nos.: 51-58

Independent method claim 51 and its dependent claims 52-58 relate to a method for the treatment of the human body by surgery because they explicitly involve the surgical step of "delivering ablative energy to the tissue [...]". According to Rule 39.1(iv) PCT, the International Searching Authority is not required to search the subject-matter of these claims.