

[54] CONTACT-LESS INITIATION OF LIGHT EMISSION FROM PHOTO LAMPS SYNCHRONIZED WITH CAMERA OPERATION

[75] Inventor: John D. Harnden, Jr., Schenectady, N.Y.

[73] Assignee: General Electric Company, Schenectady, N.Y.

[22] Filed: Oct. 27, 1969

[21] Appl. No.: 869,800

[52] U.S. Cl. .... 95/11.5 R

[51] Int. Cl. .... G03b 15/035

[58] Field of Search ..... 95/11.5; 310/8, 8.5, 310/8.7; 307/309

[56] **References Cited**  
UNITED STATES PATENTS

3,380,357	4/1968	Harvey.....	95/11.5
3,618,492	11/1971	Ellin.....	95/11.5
3,507,196	4/1970	Ruhle et al. ....	95/53 X
2,538,577	1/1951	McCarty.....	95/11.5
2,730,937	1/1956	Martin et al. ....	95/11.5
2,972,937	2/1961	Suits .....	310/8.3 X
3,106,080	10/1963	Suits .....	310/8.4 X

3,200,723	8/1965	Topaz.....	95/10 CT
3,220,326	11/1965	Scudder.....	95/10 CT
3,518,487	6/1970	Tanaka et al. ....	315/228
2,161,355	6/1939	Jacobson .....	95/11.5
2,336,633	12/1943	Parson, Jr. ....	95/11.5 UX
2,382,981	8/1945	Edgerton .....	95/11.5
2,486,010	10/1949	Edgerton.....	95/11.5 UX
3,211,069	10/1965	Rixton .....	95/11.5

OTHER PUBLICATIONS

"Hall Effect Put in IC," Robert Cushman, Edn, November 11, 1968, pp. 87-93.

Primary Examiner—Samuel S. Matthews  
Assistant Examiner—Michael L. Gellner  
Attorney—Frank L. Neuhauser, Oscar B. Waddell, Joseph B. Forman, Norman C. Fulmer and Henry P. Truesdell

[57] **ABSTRACT**

A magnetically sensitive semiconductor having a plurality of individual magnetically sensitive areas is used to trigger a photoflash lamp in synchronization with shutter operation. A magnetic field is impressed on the individual magnetic areas in time sequense. One is selectively connected to trigger the lamp to provide a selectable time delay for flash operation.

1 Claim, 20 Drawing Figures

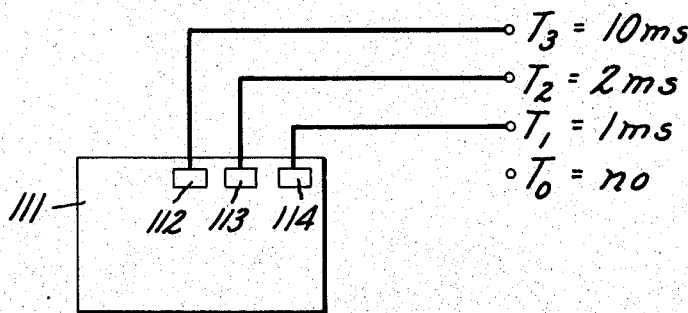

Fig. 3.

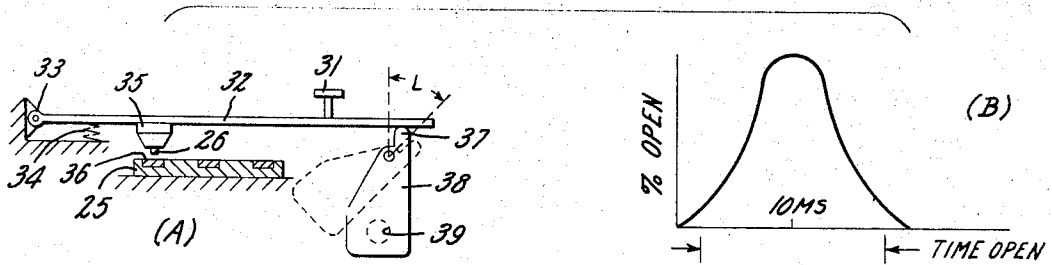

Fig. 1.

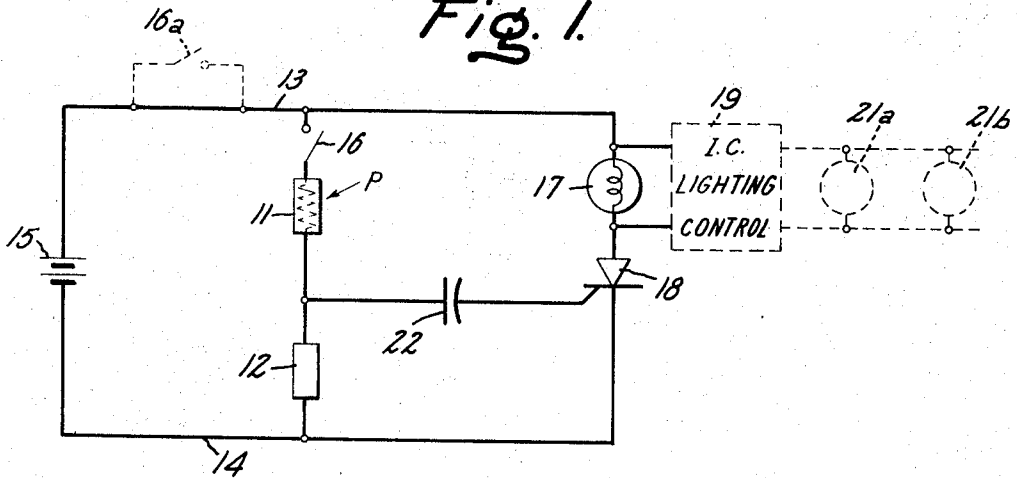
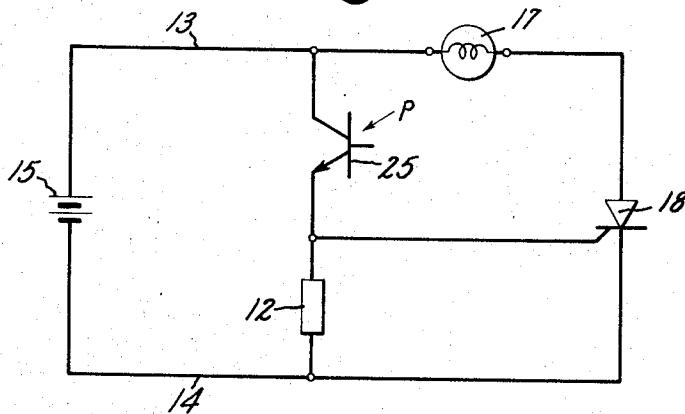
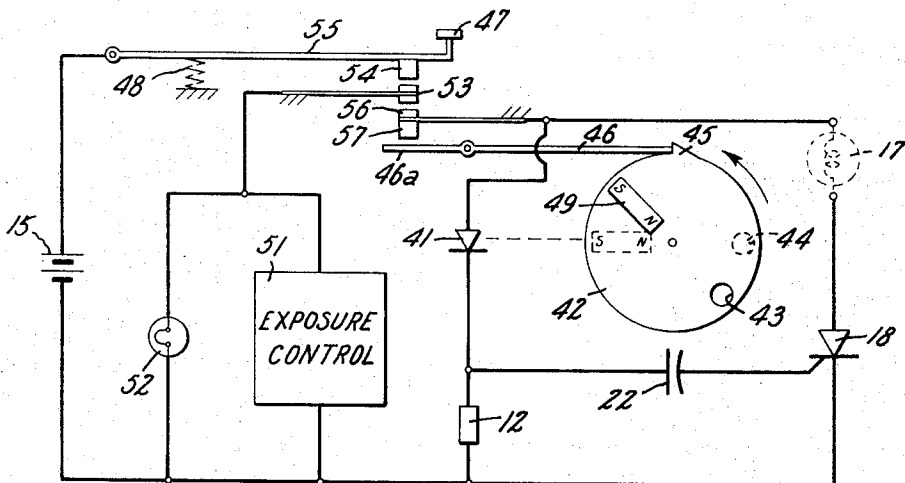
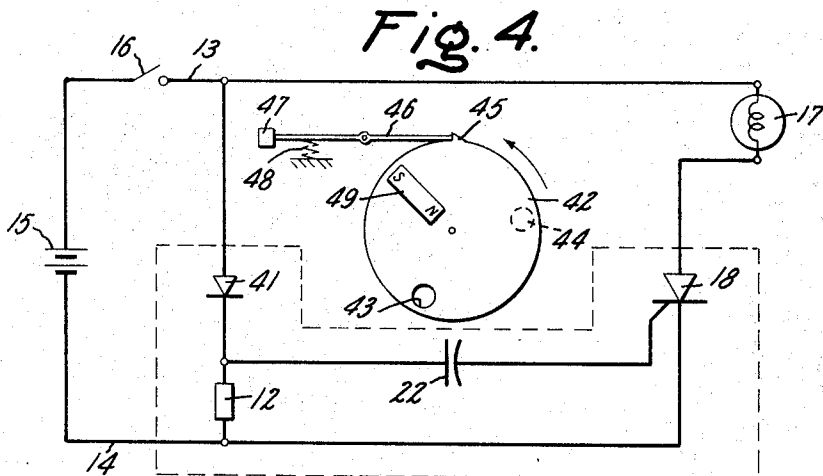
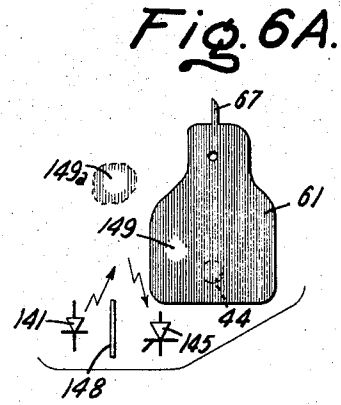
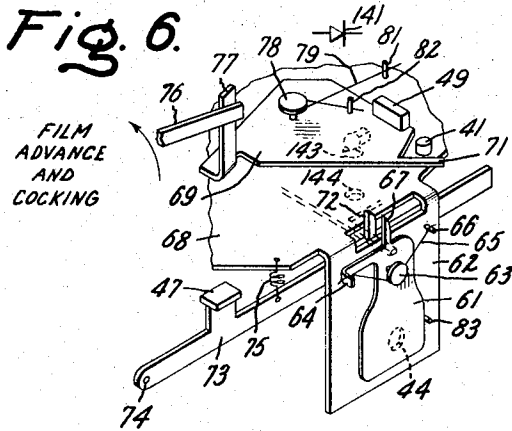

Fig. 2.



Inventor:  
 John D. Harnden, Jr.  
 by Paul A. Frank  
 His Attorney.



**Fig. 5.**

Inventor:  
 John D. Harnden, Jr.  
 by Paul A. Frank  
 His Attorney.

Fig. 7.

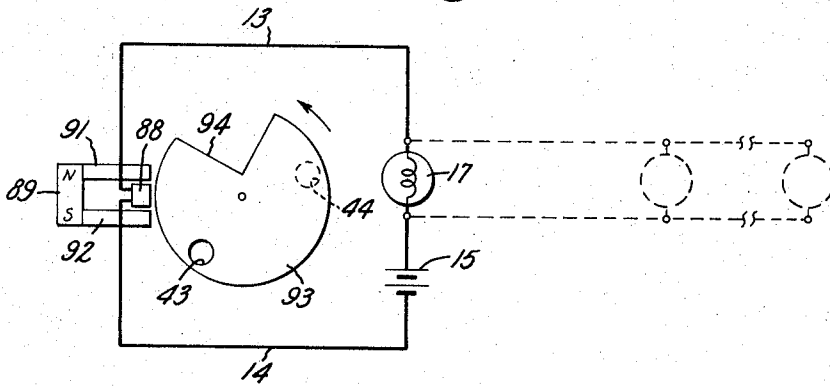

Fig. 8.

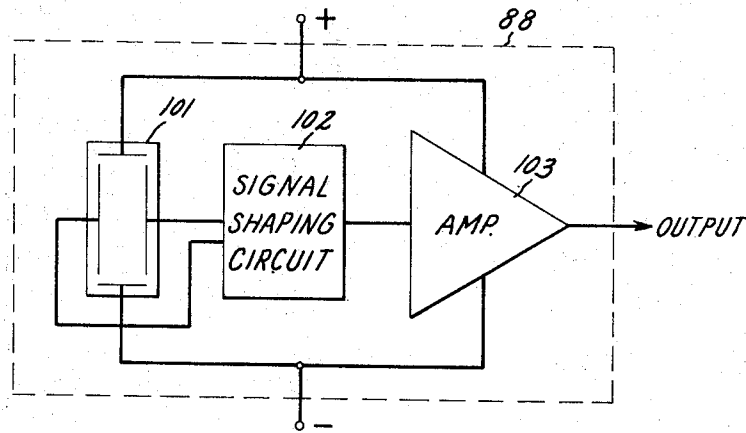
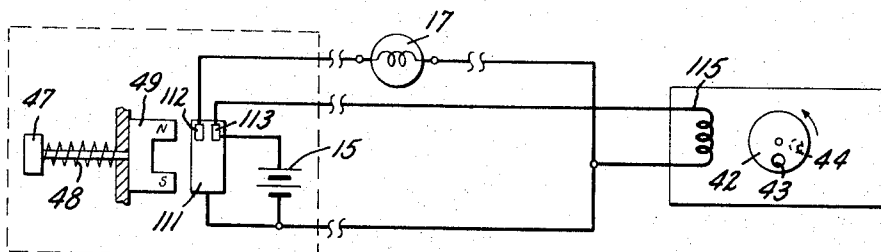

Fig. 12.



Inventor:  
 John D. Harnden, Jr.  
 by Paul A. Frank  
 His Attorney.

Fig. 9.

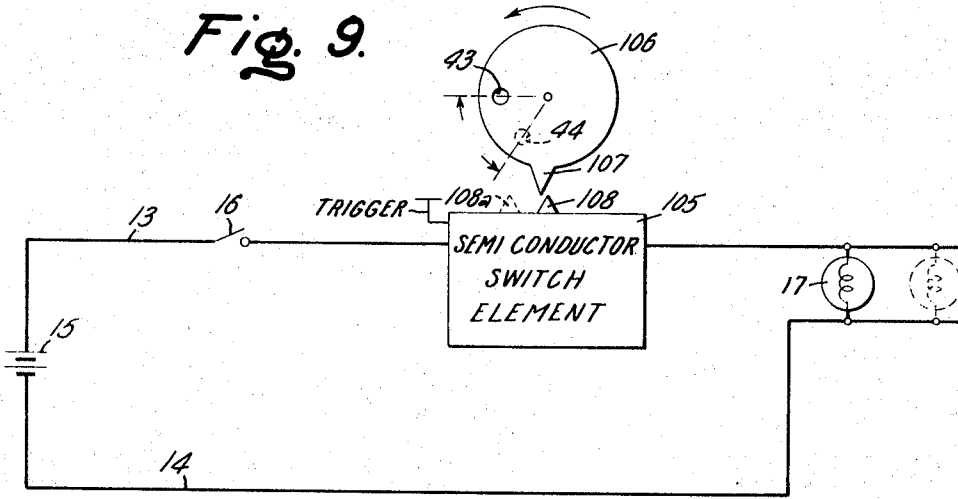

Fig. 10.

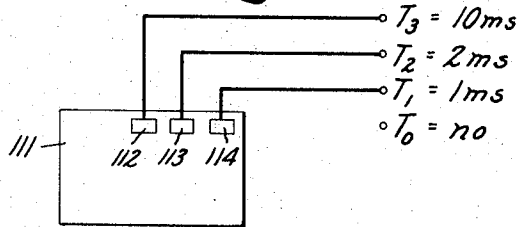
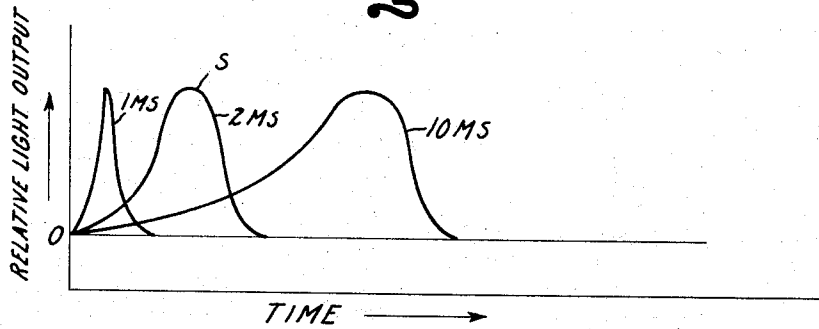

Fig. 11.



Inventor:  
John D. Harnden, Jr.  
by Paul A. Frank  
His Attorney.

Fig. 13.

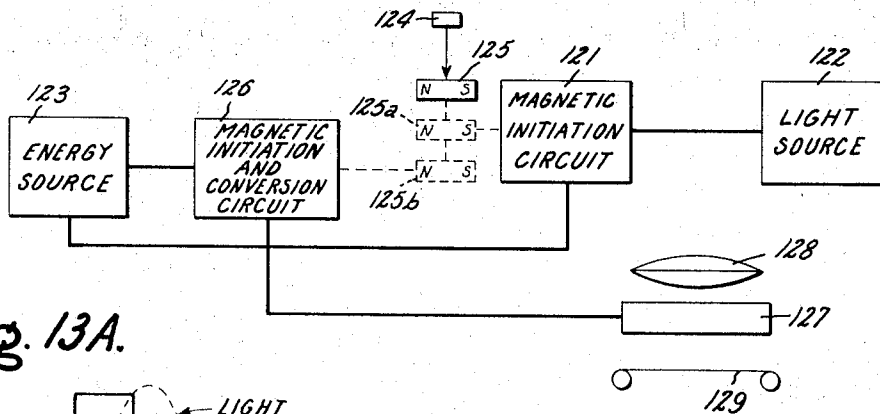

Fig. 13A.

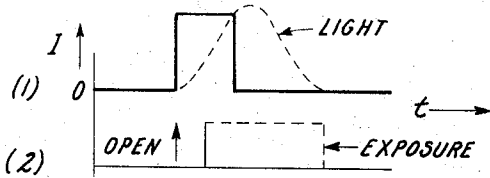

Fig. 18.

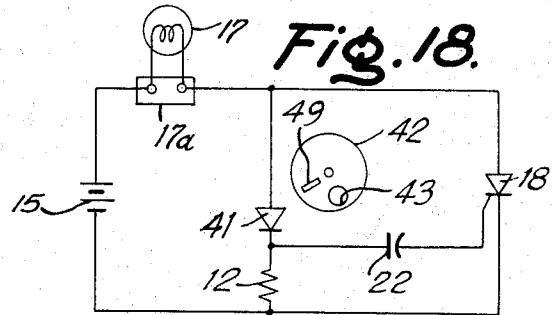
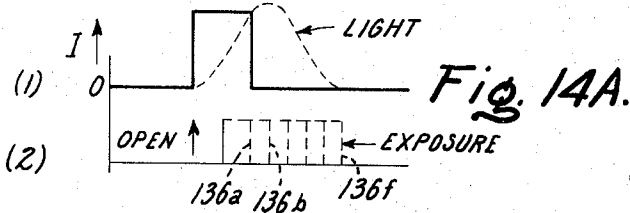
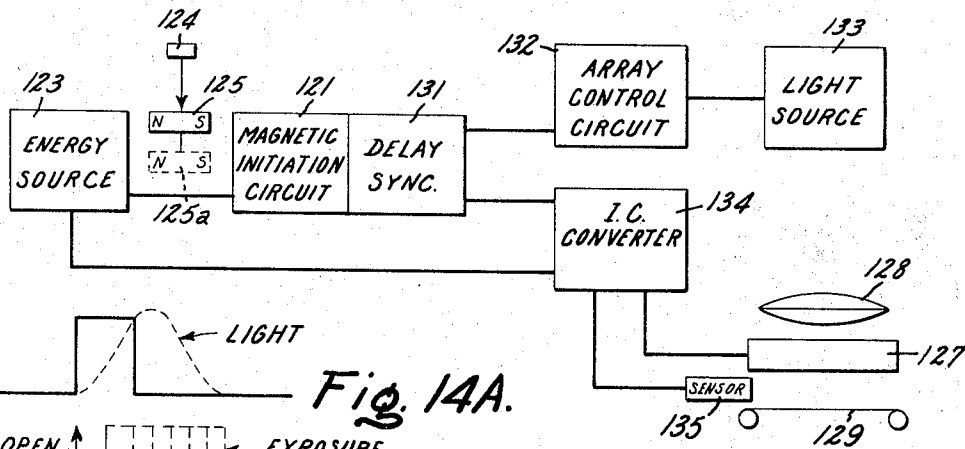

Fig. 14.



Inventor:  
 John D. Harnden, Jr.  
 by Paul A. Frank  
 His Attorney.

Fig. 16.

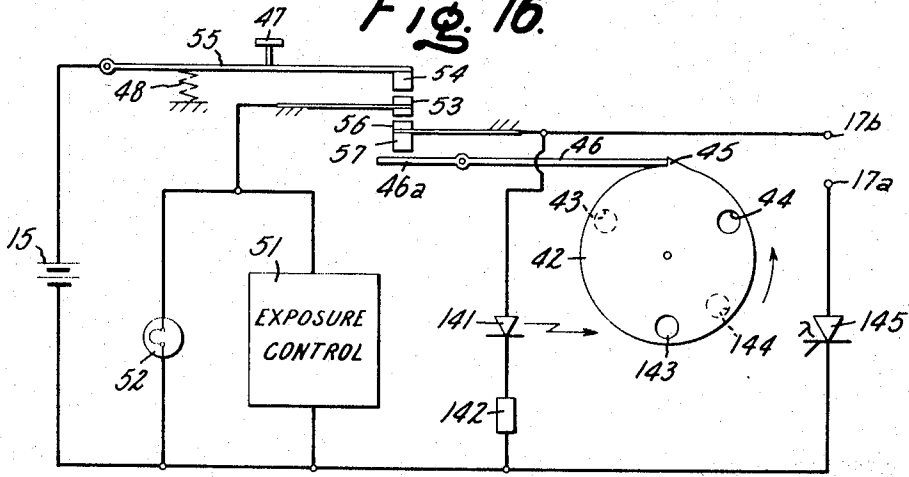

Fig. 15.

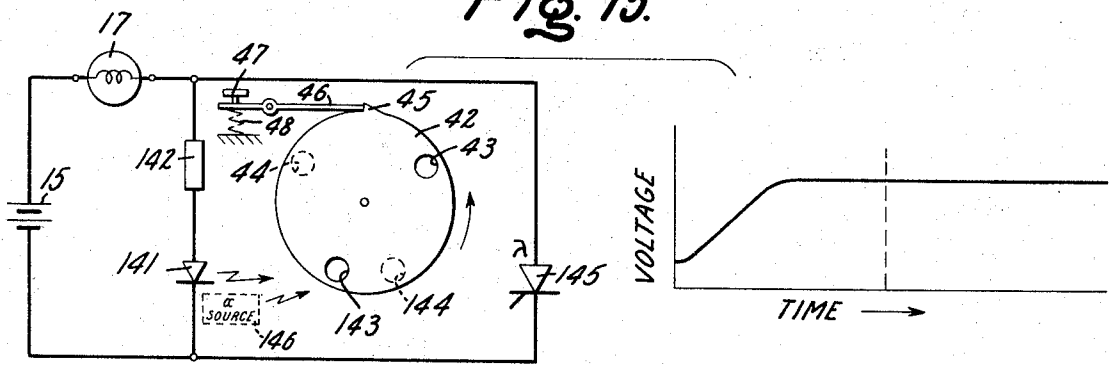
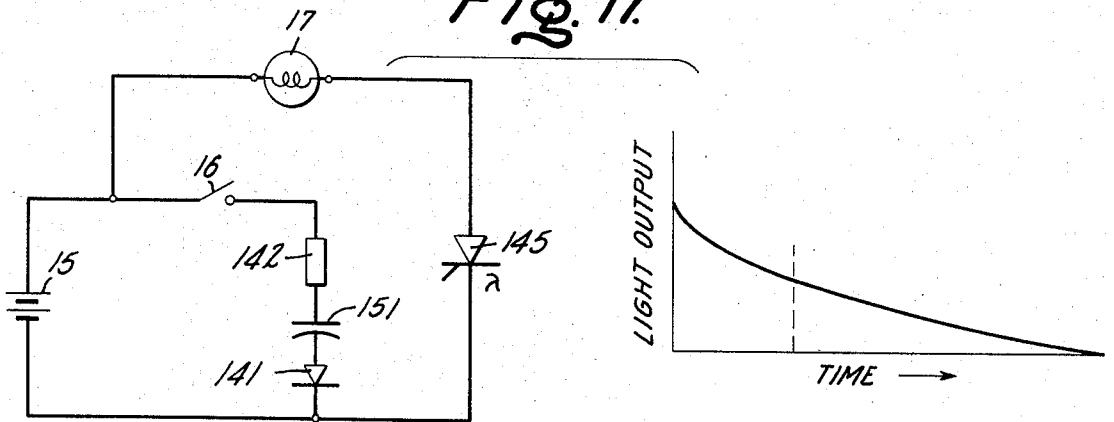

Fig. 17.



Inventor:  
John D. Harnden, Jr.  
by Paul A. Frank  
His Attorney.

**CONTACT-LESS INITIATION OF LIGHT  
EMISSION FROM PHOTO LAMPS  
SYNCHRONIZED WITH CAMERA OPERATION**

This invention relates to a new and improved family of contactless light emission initiation circuits for use in controlling operation of photo lamps employed in lighting subjects to be photographed with a camera.

More particularly, the invention relates to such contact-less photo lamp light emission initiation circuits which may be fabricated in microminiaturized integrated circuit form, are capable of reliable operation with low voltage electric energy sources, and may be included as an operating subsystem of an overall camera control system for controlling light emission together with controlled exposure of the film plane of the camera.

The introduction of the more complex shutter and variable aperture control mechanisms in cameras has required the use of miniaturized electric motors in the cameras to operate such mechanisms. This in turn places a demand on the sources of electric energy (such as batteries) to supply the increased current necessary to operate such motors. In order to meet this requirement, and also maintain the size of the battery power source within prescribed limits for use in hand-held cameras, it has proven necessary to reduce the operating voltage of the energy source to quite low values on the order of 1 - 5 volts. This low voltage requirement is further dictated by the desire to fabricate the control circuits used in such systems in microminiaturized integrated circuit form since such integrated circuits generally are required to be operated at low voltages.

Because of the low voltage requirement, it quite often happens that many camera photo lamp control circuits fail to operate reliably. This has been due to the buildup of oxidized and corrosive surface films on the switch contacts of little or minimally used mechanical switches employed in such circuits. To breakdown such surface films (where they are allowed to build up) requires higher voltage. If only 3 volts are available from the primary energy source, (such as a battery) the probability of failure in operation is quite high. To overcome this problem, the present invention was devised.

An additional problem besetting small, hand-held cameras is the jitter or bounce induced in the camera by mechanically operable switches comprising a part of the camera control mechanism. The present invention also serves to reduce such jitter, bounce or vibration whereby the chances of obtaining good picture quality are enhanced.

It is, therefore, a primary object of this invention to provide a family of new and improved contact-less light emission initiation circuits for use in controlling operation of photo lamps employed in lighting subjects to be photographed with a camera.

Another object of the invention is to provide such contact-less photo lamp light emission initiation circuits which may be fabricated in microminiaturized integrated circuit form, are capable of reliable operation with low voltage electric energy sources, and may be included as operating subsystems of an overall camera control system for controlling light emission synchronously with the controlled exposure of the film plane of the camera.

In practicing the invention, a contact-less photo lamp light emission initiation circuit is provided which comprises electric supply terminal means for connection to a source of electric energy and to photo lamp means to initiate light emission from the photo lamp means upon the establishment of a closed electric current path through the electric supply terminal means, a source of electric energy and the photo lamp means to be energized. Contact-less photo lamp light emission initiation means are connected in the current path intermediate the photo lamp means and a source of electric energy for controlling the closure of the current path to the photo lamp means whereby electrical resistance of films normally built up on conventional switch contacts and vibration, bounce, and chatter due to contact impact are minimized to thereby assure proper energization of the photo lamp means. The circuit is completed by means for synchronizing the initiation of light emission from the photo lamp means with the passage of light through the optic system of a camera with which the photo lamp light emission initiation circuit is used.

In one embodiment of the invention, the photo lamp means may comprise an array of photo lamps having control circuit means for selectively lighting desired ones of the photo lamps and the contact-less photo lamp light emission initiation means initiates the operation of the control circuit means for selectively lighting a desired one of the array of photo lamps. If desired, a mechanical on-off switch may be connected in circuit relationship with the contact-less photo lamp light emission initiation means for selectively enabling the circuit for operation and preserving the energy of the low voltage electric energy source during periods of non-use; however, such mechanical on-off switch is constructed so that it is readily self-cleaning by involving high forces. If the photo lamps are of a flashbulb type, they may be positioned in the circuit intermediate the source of electric energy and the contact-less photo lamp light emission initiation means so as to serve as the on-off switch in the manner of an electric fuse.

In another preferred embodiment of the invention, an exposure control circuit may be included in a control system along with the light emission initiation circuit for controlling the extent of exposure of the film plane of the camera to a subject being photographed in conjunction with light emitted by the photo lamp means, and such a system includes means for synchronizing operation of the exposure control circuit with the operation of the contact-less photo lamp light emission initiation means. In a still further arrangement according to the invention, the photo lamp means employed may comprise an array of photo lamps having control circuit means for selectively lighting desired ones of the photo lamps and the contact-less photo lamp light emission initiation means initiates operation of the control circuit means for selectively lighting a desired one of the array of photo lamps. In all such camera control system arrangements, the circuit components preferably are fabricated in microminiaturized integrated circuit form.

According to the particular applications in mind, the contact-less photo lamp light initiation means may be magnetically operated, it may be radiant energy operated either by light or alpha particle radiation or the like, or it may be pressure responsive. Several different forms of these basically different contact-less photo lamp light emission initiation means are disclosed.

Other objects, features and many of the attendant advantages of this invention will be appreciated more readily as the same becomes better understood by reference to the following detailed description when considered in connection with the accompanying drawings, wherein like parts in each of the several figures are identified by the same reference character, and wherein:

FIG. 1 is a schematic circuit diagram of one form of a new and improved photo lamp light emission initiation circuit constructed in accordance with the invention;

FIG. 2 is a schematic circuit diagram of still another form of a contact-less light emission initiation circuit according to the invention and which employs a pressure responsive initiation means;

FIG. 3 is a schematic functional diagram illustrating one form of mechanizing the circuit arrangement depicted in FIG. 2;

FIG. 4 is a schematic circuit diagram of a magnetic sensitive contact-less photo lamp light emission initiation circuit constructed in accordance with the invention;

FIG. 5 is a schematic circuit diagram of still another form of magnetic sensitive contact-less emission initiation circuit employing a magnetic sensitive diode;

FIG. 6 is a partial perspective view of a portion of a camera shutter mechanism illustrating the manner in which such mechanism can be modified to include either a permanent magnet or a light opening for contact-less initiation of a magnetic sensitive diode or a light sensitive diode;

FIG. 7 is a schematic circuit diagram of still another form of contact-less light emission initiation circuit according to the invention which employs a magnetic sensitive Hall element and amplifier arrangement;

FIG. 8 is a functional block diagram of the magnetic sensitive Hall element and amplifier employed in the circuit arrangement of FIG. 7;

FIG. 9 is a schematic circuit diagram of still another form of magnetic sensitive semiconductor switch element that can be employed in practicing the present invention;

FIG. 10 is a functional diagram of the layout of a magnetic sensitive semiconductor integrated circuit element that can be employed to provide certain delay functions in the operation of a light emission initiation circuit employing such an element;

FIG. 11 is a series of characteristic curves illustrating the intensity of light emitted vs. time characteristic of a light emission initiation circuit employing the circuit of FIG. 9 with the magnetic sensitive semiconductor switch element of FIG. 10;

FIG. 12 is still a different form of magnetic sensitive contact-less light emission initiation circuit showing an alternative manner of achieving different time delays in the operation of various portions of the circuit;

FIG. 13 is a functional block diagram of a camera control system providing both contact-less light emission initiation in accordance with the invention and electronically controlled exposure of the film plane of a camera;

FIG. 14 is a functional block diagram of still different and improved camera control system according to the invention which provides synchronized contact-less light emission initiation, control over the flashing of selected ones of an array of photo lamps, and electronic

control of the exposure of the film plane of a camera;

FIG. 15 is a schematic circuit diagram of an embodiment of the invention employing a light emitting diode as part of the contact-less light emission initiation means;

FIG. 16 is a schematic circuit diagram of a different form of the contact-less light emission initiation circuit employing a light emitting diode and light activated silicon control rectifier to initiate light emission in a contact-less manner;

FIG. 17 is a schematic circuit diagram of still a third form of contact-less light emission initiation circuit employing a light emitting diode and including a capacitor for conserving energy of the low voltage electric energy source employed for circuit energization purposes; and

FIG. 18 is a schematic circuit diagram of a modification of the circuit of FIG. 4.

FIG. 1 is a schematic circuit diagram of a contact-less photo lamp light emission initiation circuit constructed in accordance with the invention, and which employs a pressure sensitive strain gauge element shown at 11 as a contact-less photo lamp light emission initiation means. The pressure sensitive element 11 may comprise any known form of pressure or strain sensitive device which changes its electrical resistance in response to the application of a pressure or strain to its pressure sensitive area. The pressure sensitive element 11 is connected in series circuit relationship with a load resistor 12 across a pair of power supply terminals 13 and 14 that in turn are adapted to be connected across a source of electric energy 15. The source of electric energy 15 may comprise any known portable source of electric energy but preferably comprises a low voltage battery having a terminal output voltage of approximately 3 volts or less and a short circuit current of about 2 amperes, although the circuit is in no way restricted to use only with energy sources of this voltage rating. With the circuit thus comprised, a conventional mechanically operable on-off switch 16 is included in the series circuit comprising pressure sensitive element 11 and load resistor 12. For a reason to be explained more fully hereinafter, the on-off switch 16, if needed, should be located in a position so that its variable on resistance would have minimum effect. As an alternative the switch 16 can be eliminated and a switch 16a shown in dotted outline form could be included in the circuit in place of switch 16. In either case, higher forces and self cleaning result as compared with normal shutter operated contacts at low level.

In addition to the above-mentioned circuit components, the power supply terminals 13 and 14 also are connected across a series circuit branch formed by a photo lamp means comprising a socket or a plurality of sockets for receiving the base of a conventional photo lamp in the photo lamp means is connected in series circuit relationship with the load terminals of a gate operated semiconductor switching means 18. The photo lamp means may comprise a conventional bayonet type receptacle for receiving a single photo lamp flashbulb such as the M5 or M2 flashbulbs or the A G-1 flashbulb manufactured and sold by the Photo Lamp Department of the General Electric Company or some similar photo lamp. The photo lamp means also may comprise the photo flashbulb itself, a solid state junction light source such as a light emitting diode, a repeatable electronic discharge type of light bulb, a flash cube, a strobe light or the photo lamp means 17 may even comprise an in-

tegrated circuit type of lighting control shown in dotted outline form at 19 for selectively controlling the lighting or flashing of desired ones of an array of photo lamps such as shown in dotted outline form at 21a, 21b, etc. Thus, it will be appreciated that the photo lamp means 17 employed in the embodiment of the invention shown in FIG. 1 as well as in other embodiments of the invention to be described hereinafter, may comprise any one of the above-listed devices and/or the receptacles or sockets for receiving such devices. It is to be understood, therefore, that while only a single photo lamp 17 will be shown in the remaining embodiments of the invention disclosed herein, such depiction is intended to include any of the above-mentioned photo lamp means and similar devices.

The gate control semiconductor switching means 18 may comprise a conventional gate control silicon controlled rectifier (SCR), a silicon unilateral switch (SUS), a programmable unijunction transistor (PUT), a silicon bilateral switch (SBS), a complementary unijunction transistor (CUJT), a Schmidt trigger or other form of gate controlled solid state semiconductor switching device fabricated either in discrete or integrated circuit form. Any of these devices may be obtained from a number of manufacturers such as the Semiconductor Products Department of the General Electric Company, and their characteristics are well-known to the art.

The control gate of the semiconductor switching device 18 is coupled through a coupling capacitor 22 to the juncture of the pressure sensitive element 11 with the load resistor 12. With this arrangement, upon the on-off switch contacts 16 being closed and the application of a sharp striking blow or other means for suddenly increasing the pressure on the pressure sensitive surface of element 11, the current flowing through the load resistor 12 will be sharply increased. The coupling capacitor 22 operates to convert the sharp increase in voltage appearing across the load resistor 12 to a gating current applied to the gating electrode of the semiconductor switching device 18 to render it conductive and thereby supply a light emission initiating current flow through the photo lamp means 17.

As was noted earlier, the on-off switch 16 is physically located in a preferred position such that its switch contacts do not carry full currents and low contact-resistance is not a requirement. Also, since either 16 or 16a are not tied in with the shutter they are more successfully cleaned by the unskilled. This arrangement is in contrast to many prior art devices wherein mechanically operable, on-off switch contacts are mounted and operate synchronously with the shutter mechanism of the camera, etc., and must be located in a position within the camera so as not to be accessible for cleaning. Assuming therefore that the switch contacts 16 are cleaned so as not to constitute a considerable increase in resistance, and if a low voltage battery source 15 is employed having a voltage on the order of 3 volts, sufficient current will be supplied through the load resistor 12 to gate on the SCR or other gate-controlled semiconductor switching device 18. For this purpose, something on the order of 20 - 200 microamperes of gating current must be supplied to the gate electrode of the switching device 18. It will be appreciated, therefore, that only a minute amount of current is required to trigger on the gate control switching device 18 which

thereafter supplies the main light flash initiating current through the photo lamp 17.

If the photo lamp 17 comprises a conventional, expandable photo flash lamp of the General Electric M-2 type, it will require about 1 ampere of current at 0.7 of a volt to assure reliable flashing. With the circuit arrangement shown in FIG. 1, flashing current and voltage of this magnitude is assured since with the semiconductor switching device 18 gated on in its conducting condition the forward voltage drop through the device is only a fraction of a volt. From a consideration of the circuit shown in FIG. 1, particularly where the on-off switch 16 is included in the circuit branch with element 11 and load resistor 12 and is not connected intermediate the low voltage battery source 15 and the photo lamp 17, substantially the full voltage of the source 15 minus only the forward drop of the semiconductor switching device 18 is applied across photo lamp 17 to assure reliable flashing of the photo lamp. It should be noted that with either arrangement employing the on-off switch 16, or the alternative arrangement shown in dotted outline form at 16a, it is necessary that the switch contacts be readily accessible for cleaning so as to minimize any voltage drop across the switch contacts.

It may be necessary to include a mechanical on-off switch in the contact-less light emission initiation circuit shown in FIG. 1 due to the fact that without such a switch, current could continuously flow through the pressure sensitive resistance element 11 and load resistor 12 and ultimately bleed off the energy of the battery source 15. However, the high "off" resistance of semiconductor 18 and certain pressure sensors 11 could result in leakages less than the normal battery leakages and thus would result in life approaching shelf life. In all events, it will be seen that the electric current flow required to initiate light emission from the photo lamp is developed internally through internal operation of the pressure sensitive resistor element 11 so that only a minute current flow will suffice to initiate conduction of the gate controlled semiconductor switching device 18. Because of this internal generation or development of the required light flash initiating current, and the fact that such current is not required to puncture an external oxidized or other corrosively coated surface film formed on a set of switch contacts, the circuit arrangement can be said to be contact-less in nature in that it possesses less vulnerable contact resistance than previously available light emission initiation circuits.

Pressure transistors with high off-resistances are presently more common than 2 terminal pressure devices with similar properties. Thus, an arrangement such as shown in FIG. 2 of the drawings may be employed to avoid all switches. The circuit arrangement shown in FIG. 2 is comprised by a contact-less photo lamp light emission initiation means 25 connected in series circuit relationship with a load resistor 12 across the power supply terminals 13 and 14 which are designed to be connected across the load terminals of a low voltage battery source 15. The contact-less photo lamp light emission initiation means 25 comprises a pressure sensitive semiconductor device such as piezoelectric pressure transistor similar to that offered for sale by the Stow Laboratories of Stow, Mass., announced in the *Electronics Magazine*, January 23, 1967 issue. The pressure sensitive transistor 25 includes a pressure sensitive area 36 that is exposed to a small cap

26 mounted on an anvil 35 as shown in FIG. 3 for applying mechanical stress to the emitter-base junction of the transistor. Upon such mechanical stress or pressure being applied, an electrical current is allowed to flow through the device. Otherwise, the device remains in a current blocking condition while it is in the unstressed condition and no current flow from the battery source 15 takes place through the circuit branch comprised by the pressure sensitive transistor 25 and the load resistor 12.

The juncture of the load resistor 12 and pressure sensitive transistor 25 is connected to the control gate of a semiconductor switching element 18 such as an SCR, SUS, etc., that in turn has its load terminals connected in series circuit relationship with the receptacle for receiving a photo lamp means 17 which of course may comprise either a single photo flash lamp or similar device. It is necessary in the circuit of FIG. 2, however, that the photo lamp means 17 be of the photo flash type which burns out or open-circuits upon being flashed. With this arrangement, the photo flash lamp 17 will function as an on-off switch in the manner of a fuse to open the circuit connection through the load terminals of the gate control semiconductor switch 18 after being flashed. This is important since the gate controlled semiconductor 18 is of the thyristor type which once being gated into conduction remains in conduction until the current flowing through the device has been reduced below a minimum holding value. Upon this occasion, the device will re-assume its blocking condition until again gated on by the application of a gating signal to its gating electrode. Thus, it will be seen that the photo flash lamp 17 upon being flashed will serve to commutate off the gate control semiconductor device 18, and cause it to be returned to its current blocking condition. Thereafter, a user of the circuit may reinsert a new flashbulb safely since the gate control semiconductor switching device 18 is in its current blocking condition and will prevent application of electric current to the flash initiating current terminals of the receptacle for receiving photo flash lamp 17 while a new bulb is being inserted.

With the circuit arrangement shown in FIG. 2, it should be noted that with respect to the gating on circuit element comprised by the contact-less, pressure sensitive transistor 25, load resistor 12 and low voltage battery source 15, there are no mechanical on-off switch contacts in this circuit branch. The light emission initiating switching action takes place internally in the pressure sensitive semiconductor switching device 25 upon the cap or anvil 26 contacting the pressure sensitive area of the semiconductor device 25 as shown in FIG. 3. Thus, the light flash emission initiating current need not puncture or pass through a high resistance film in order to develop the desired light emission initiating gating on current pulse to be supplied to the control gate of the semiconductor switching device 18. Similarly, the switching device 18 operates only through internally protected current paths to supply the light flash initiating current to the input terminals of the photo flash lamp 17. The only contact surfaces in the circuit are those provided by the socket or receptacle in which the photo flash lamp 17 is secured. These contact surfaces normally will be subjected to a cleaning action by reason of the insertion and removal of the photo flash lamp base into the receptacle under high force levels. Additionally, it should be noted that the

receptacle itself is external of the camera or other housing for the light emission initiating circuit, and hence can be cleaned readily by a user of the equipment should the abrasive cleaning action of the insertion and removal of the photo flash lamp not prove sufficient. For these reasons the contact-less photo lamp light emission initiation circuit shown in FIG. 2 is highly reliable in operation even with very low voltage battery sources.

FIG. 3A of the drawings illustrates one form of a mechanical actuating mechanism for applying pressure or stress to a stress sensitive area of the semiconductor element 25. In this arrangement, a pushbutton 31 for actuating a camera associated with the light emission initiation circuit, is attached to a lever arm 32 pivoted at a point 33 against the action of a return spring 34. An anvil 35 is formed on one surface of the lever arm 32 and has the cap 26 attached thereto at a point directly opposite the pressure sensitive surface 36 of the pressure sensitive semiconductor element 25. The end of lever arm 32 operates against a cam surface 37 of a shutter 38 which normally closes the aperture shown at 39 used to expose the film plane of the camera. Upon the pushbutton 31 and lever arm 32 being depressed by a user of the camera, the anvil 35 and cap 26 will be brought into contact and will apply stress or pressure to the pressure sensitive area of the semiconductor device 25 thereby initiating current flow through the device and hence photo lamp 17 of FIG. 2 in the manner previously described. Simultaneously with this action, the cam surface 37 will cause the shutter 38 to be pivoted to the position shown in dotted outline form thereby exposing the aperture 39 and hence the film plane of the camera.

The mechanical angular relationship of the opening of shutter 38 to the point where the cap 26 on anvil 35 strikes pressure sensitive transistor 25 is such that the opening of aperture 39 occurs after a short delay period related to the time required for the flash bulb to emit its peak intensity of light. This relationship is depicted in FIG. 3B of the drawings wherein the percent opening of the aperture 39 is plotted against time. From a review of FIG. 3B it will be seen that the percent opening of aperture 39 goes from 0 value to a maximum value after a period of about 10 milliseconds following depression of the pushbutton 31. The curve shown in FIG. 3B also could be employed to illustrate the emission of light characteristics of the photo flashbulb where the intensity of light is plotted as the ordinate and the time required to emit a given amount of light is plotted as the abscissa. It will be seen that the mechanical relationship of the opening of the aperture 39 is designed to coincide substantially with the maximum light intensity emission of the photo flash lamp 17 with which the circuit is designed to be used. It might also be noted that while in FIG. 3 the cap 26 is shown as being mounted on anvil 35, the mounting of the cap on the semiconductor surface 36, or other similar alternatives also could readily be achieved.

FIG. 4 of the drawings is a schematic illustration of still another form of contact-less photo lamp light emission initiation circuit employing a magnetic sensitive diode 41 as the contact-less photo lamp light emission initiation means. The magnetic sensitive diode 41 is connected in series circuit relationship with a load resistor 12 across the power supply terminals 13 and 14 and through on-off switch 16 to the electric energy

source 15 which may comprise a low voltage battery of about 3 volts. The magnetic sensitive diode 41 may be similar to the one manufactured and sold by the Sony Electric Company of Japan. Alternatively, a magnetic sensitive transistor such as described in *Electronic Design News*, February 15, 1969 issue, a magnetic sensitive Hall element or other magnetic sensitive semiconductor device could be employed in place of the diode 41 as will be described more fully hereinafter. Similar to earlier described circuits, the juncture of the magnetic sensitive diode 41 and load resistor 12 is coupled through a coupling capacitor 22 to the control gate of the semiconductor switching device 18 such as an SCR, SUS, etc. The load terminals of the switching device 18 in turn are connected in series with the photo lamp means 17 for selective energization in the manner described hereinafter.

A rotatable shutter plate 42 which is spring biased to rotate in a counterclockwise direction as shown by the arrow includes an aperture opening shown at 43 which upon rotation into alignment with the aperture or passageway providing an optic path to the film plane of a camera (shown at 44), will operate to expose the film plane to a subject being photographed. The shutter plate 42 can be pre-wound by means of a trigger mechanism (not shown) by an operator of the camera and is prevented from unwinding by a stop 45 formed on its periphery. In the pre-wound condition, the stop 45 is engaged by the end of a release lever arm 46 that in turn is actuated by a pushbutton 47. Upon the pushbutton 47 being depressed against the action of a return spring 48, the end of lever arm 46 allows the rotatable shutter member 42 to be rotated in the direction shown by the arrow.

The rotatable shutter plate 42 also includes a permanent magnet shown at 49 which is mounted on its periphery and which is adapted to influence or magnetically permeate the magnetically sensitive area of the magnetically sensitive switching element 41 upon being rotated in the previously described manner. It is desirable that the magnetic energization of the magnetically sensitive semiconductor diode 41 take place slightly in advance of the aperture opening 43 becoming aligned with the aperture 44 so that upon the latter occurrence, the light emitted by the photo lamp 17 has reached substantially its peak intensity. This can be accomplished by appropriate design of the angular location of the permanent magnet 49 on the rotatable shutter plate 42 relative to the positions of the aperture opening 43 on the shutter plate and the aperture 44 which is of course located on a different part of the camera and is in a fixed position relative to the rotatable shutter plate 42.

In operation, the circuit of FIG. 4 functions in the following manner. In this description, it is assumed that an operator has inserted a photo lamp 17 in the socket designed to receive such photo lamp and has pre-wound or cocked the camera so as to condition the rotatable shutter plate 42 to be rotated through the action of a pre-wound spring (not shown) in the manner described above. If a mechanical on-off switch 16 is located in the circuit as indicated, it would then be closed to condition the circuit for operation. However, it should be noted that the circuit could be modified to eliminate the on-off switch 16 by placement of the photo lamp 17 receiving socket 17a in the circuit at the point where the on-off switch presently is located, as shown in FIG. 18. By such arrangement, the photo lamp could oper-

ate in the manner of a fuse. However, for such an arrangement, the photo lamp 17 would have to be of a filament type which will allow sufficient trickle current to flow through its filament to render the diode 41 conductive.

After conditioning the circuit of FIG. 4, an operator of the camera is then ready to trip the camera for picture taking purposes. Upon this occasion, the pushbutton 47 is depressed thereby releasing the rotatable shutter 42 in the above briefly described manner. This results in aligning the magnetic field of the permanent magnet 49 (at least instantaneously by reason of the rotational scanning of the field of the permanent magnet past the magnetically sensitive semiconductor diode 41) so as to trigger the diode 41 into conduction. This results in the production of a current pulse in the gate-emitter circuit of SCR 18 by reason of the co-action of the load resistor 12 and coupling capacitor 22 and triggers the semiconductor switch 18 into conduction thereby igniting or flashing the photo lamp 17. As previously stated by reason of their relative angular location on rotatable shutter 42, flashing of the photo lamp 17 is initiated somewhat in advance of the aperture opening 43 exposing the aperture 44 and hence film plane of the camera so that such exposure coincides substantially with the maximum or peak intensity of the light emitted by the photo lamp 17. It will be appreciated, therefore, that the resulting light flash initiation is derived through internal action of the magnetically sensitive semiconductor diode 41 without requiring that the low voltage source 15 provide sufficient energy to punch through any oxidized or corrosive surface film that might build up on switch contacts that are not readily accessible for cleaning. The switch contacts of the on-off switch 16 (should it be used as shown in FIG. 4) can be designed to be self-cleaning and operable at high force levels. Thus, it will be appreciated that the magnetically sensitive diode 41 constitutes another form of contact-less photo lamp light emission initiation means according to the invention.

FIG. 5 of the drawings is a schematic illustration of a contact-less light emission initiation circuit which has been constructed using the trigger mechanism (shown in FIG. 6) along with the other components of an Eastman Kodak model 134 "Instamatic" camera. This particular camera includes an electro-optic exposure control shown at 51 which operates in conjunction with a light source 52 through the medium of an intermediate switch contact 53 that is closed initially upon the operator of the camera depressing the pushbutton 47 against the action of a return spring 48. The closing of the intermediate switch contact 53 onto a switch contact 54 formed on the pivoted lever arm 55 (with the pushbutton 47 in the depressed position), allows electric current from the electric energy source 15 (which may comprise a low voltage battery source) to flow to the exposure control circuit 51 and to a light source 52 to indicate to the user of the camera that the battery source 15 is working, and that the exposure control 51 is energized. The exposure control 51 then operates automatically in the manner of a photometer to set the aperture opening of the camera in accordance with ambient lighting conditions.

Subsequent to the energization of the exposure control circuit 51 the pushbutton 47 will continue its travel downwardly so as to close the intermediate switch contact 53 onto a third switch contact 56. Contact 56 in-

cludes an extension 57 that operates against the end 46a of a centrally pivoted lever arm 46. The remaining end of the centrally pivoted lever arm 46 operates to stop the rotation of a rotatable shutter member 42 as was described previously in connection with FIG. 4 of the drawings. The rotatable shutter member 42 is acted upon by a pre-wound spring (not shown) which tends to rotate the shutter member 42 counterclockwise in the direction of the arrow. Mounted on the rotatable shutter member 42 is a permanent magnet 49 and an aperture opening 43 is formed in the member for exposing the aperture 44 shown in dotted outline form to thereby expose the film plane of the camera. This portion of the circuit operates in precisely the same manner as the embodiment shown in FIG. 4.

Upon an operator of the camera placing the camera in condition for the taking of a picture, he will have pre-wound the spring that drives the rotatable shutter member 42, inserted an unused photo flashbulb 17 in the socket for receiving the same and properly lined up the camera for the taking of a picture. Thereafter, upon depressing the pushbutton 47, the following sequence of operations will occur. First, during the initial portion of the downward travel of the free end of the pivoted lever arm 55, the switch contacts 54 and 53 will close so as to energize the exposure control 51 and the indicating light 52, thereby indicating to the user of the camera that all is well and he can continue to depress the pushbutton 47 further so as to consummate the taking of the picture. Thereafter, further depression of the pushbutton 47 causes the switch contacts 53 and 56 to engage so as to enable the photo flash lamp 17 to be flashed. However, because the semiconductor switching element 18 is in its current blocking condition the photo lamp 17 will not be flashed.

Further depression of the pushbutton 47 will then cause the extension 57 to rotate the end 46a of lever arm 46 downwardly in a counterclockwise direction so as to release the end 46 from the stop 45. The pre-wound spring will rotate the shutter member 42 in a counterclockwise direction shown by the arrow so as to align the magnetic field of the magnet 49 with the magnetically sensitive, contact-less, photo lamp light emission initiation means comprised by the magnetically sensitive diode 41. This results in the production of a gating-on current in the gate-emitter of the semiconductor switch means 18 causing it to be rendered conductive and to supply a light emission initiating current to the filament, fibrous material, gaseous material, or other light emission substance in the photo lamp 17. As stated previously, the relative positions of the permanent magnet 49 and the aperture opening 43 on the rotatable shutter member 42 are pre-designed to allow coincidence of peak or maximum light emission with the exposure of the aperture or other optic path opening to the film plane of the camera.

FIG. 6 of the drawings is a partial, perspective view of an actual shutter mechanism employed in the construction of a contact-less photo lamp light emission initiation circuit having the circuit features illustrated schematically in FIG. 5. The shutter mechanism shown in FIG. 6 is similar to that employed in the model 134 Instamatic camera manufactured and sold by the Eastman Kodak Company. This shutter mechanism includes a shutter plate 61 which is rotatably suspended by a pivot 63 over an aperture of the camera shown at 44 formed in a back supporting plate 62. The shutter

plate 61 includes a spring tensioning arm 64 which is acted upon by a wire tension spring 65 supported between the pivot 63, the tension arm 64 and a pin 66 secured to the back supporting plate 62. The spring is arranged such that in its normal, quiescent condition, the shutter plate 61 is supported in the position shown in solid lines closing the aperture opening 44 which provides a light optic path to the film plane of the camera.

The shutter plate 61 also includes a trigger arm 67 which extends above a planar right angle extension 68 of the back supporting plate 62 and which is disposed substantially at right angles with respect to the back supporting plate 62. The extension supporting surface 68 has rotatably mounted on it a trigger plate 69 having an amplifying arm 71 which is designed to engage the trigger arm 67 of the shutter plate 61 and to rotate it in a clockwise direction from its quiescent position shown in FIG. 6. When the trigger arm 67 is rotated clockwise by the amplifying arm 71, aperture 44 will be exposed allowing the image of an object being viewed by the camera to be projected through the optical path provided by the aperture 44 to the film plane of the camera, in a well-known manner. To assure proper operator control of the opening of the shutter plate 61, the trigger plate 69 is designed to be rotated clockwise from the position in which it is shown in FIG. 6 to the dotted line position shown. When this prewound or cocked, the amplifying arm 71 is engaged behind a release pin 72 formed on a cantilever arm 73 pivotably supported at 74 and tensioned in an upward position by the action of a bias spring 75. The bias spring 75 holds the cantilever arm 73 in its upward position so that the stop 72 prevents the amplifier arm 71 from rotating into engagement with the trigger arm 67 of shutter plate 61. The trigger plate 69 is rotated into its cocked or set condition by means of a conventional film advance and cocking mechanism (not shown) having a wiper arm shown at 76 that engages an upwardly extending tab 77 formed on the trigger plate 69. Trigger plate 69 is rotated around the pivot point 78 against the action of a hair spring shown at 79 supported between a pin 81 secured to the surface 68, or some similar fixed surface on the housing of the camera, and a pin 82 secured on the trigger plate 69.

With the above arrangement, upon the camera film being advanced, it will automatically cock the trigger plate 69 into its preset or wound condition shown in dotted outline form against the action of the hair spring 79 which tends to return the trigger plate to its quiescent condition shown in solid lines in FIG. 6. The magnetic diode shown at 41 in FIG. 5 is mounted on the camera housing in a position closely adjacent the trigger plate 69 and a permanent magnet 49 is secured to the trigger plate 69 in a position such that its magnetic field will sweep past and act upon the magnetic sensitive diode 41 upon the trigger plate 69 traveling from its cocked or wound position shown in dotted outline form to its quiescent condition shown in solid form in FIG. 6. The location of the magnetic sensitive diode 41 on the camera housing should be such that it is triggered into conduction prior to the shutter plate 61 being fully rotated to a position wherein the aperture 44 is fully exposed. By thus properly locating diode 41 relative to the permanent magnet 49, the diode can be triggered into conduction at a point such that maximum light intensity produced by photolamp 17 is

achieved substantially concurrently with the full opening of the aperture 44 by the shutter plate 61.

In operation, it will be seen that upon the film of the camera being advanced to a new, unused portion, the film advance and cocking mechanism automatically will cock the trigger plate 69 to its prewound condition shown in dotted outline form. In moving to this condition, the amplifying arm 71 will be enabled to ride over the tapered or curved surfaces of the release pin 72 and trigger lever arm 67. A stop or pin 83 prevents the shutter plate 61 from being rotated counterclockwise to a position sufficient to expose the aperture 44 during the cocking or film advance operation. There, the amplifying arm 71 will be blocked in back of release pin 72 until such time that the operator of the camera depresses the pushbutton 47. At this point, the amplifying arm is swept to its solid line position by the action of hair spring 79 thereby rotating lever arm 67 and shutter plate 61 in a clockwise direction, triggering the magnetic sensitive diode 41 and exposing the aperture opening 44 in the above-described manner.

The embodiment of the invention shown in FIG. 6 possesses certain undesirable characteristics in that it requires the use of a relatively high mass permanent magnet 49 to be mounted upon the movable trigger plate 69. This requirement in itself tends to limit the speed of response of the overall trigger mechanism and adversely affects its performance. To avoid this possible limitation, an arrangement such as shown in FIG. 7 may be employed. In FIG. 7 a photo lamp means 17 is designed to be energized from a low voltage source of electric energy comprised by a battery 15 through power supply terminals 13 and 14 and the selective switching action of a contact-less, magnetic sensitive, integrated circuit Hall element and amplifier shown at 88. The construction and operation of the magnetic sensitive Hall element and integrated circuit amplifier 88 will be described more fully hereinafter in connection with FIG. 8 of the drawings. However, for the purpose of the present description, it is believed to be sufficient to point out that this element is magnetically sensitive and can be designed to provide a sharp output current pulse in response to the application of a magnetic field to the magnetic sensitive areas of the element.

A permanent magnet 89 having a pair of magnetically permeable legs 91 and 92 positioned with the legs 91 and 92 straddling the magnetically sensitive Hall element and amplifier 88. A magnetically permeable rotatable member 93 which may be in the form of a very thin disc of magnetically permeable material, is secured so that its periphery normally is disposed opposite the ends of the legs 91 and 92. While thus arranged, the rotatable member 93 serves to short circuit or bypass the lines of magnetic flux from the ends of the legs 91 and 92 around the magnetically sensitive Hall element and integrated circuit amplifier 88. A slot shown at 94 is formed in the periphery of the rotatable member 93, so that upon being disposed opposite the ends of the legs 91 and 92, no short circuiting magnetic path will exist, and the magnetic flux from the permanent magnet 89 will be diverted through the magnetically sensitive Hall element and integrated circuit amplifier 88. The rotating and release mechanism for the rotatable plate 93 has not been illustrated in FIG. 7, since these features of the mechanism have been described adequately in FIG. 4 and other figures of the drawings. An aperture

43 is formed in the rotatable member 93 at an angular position such that it will coincide with the aperture or other optical coupling path to the film plane of the camera such as is shown in dotted outline form at 44. Here, again, the arrangement is such that the magnetically sensitive Hall element and integrated circuit amplifier 88 will be triggered into conduction at a point such that maximum light intensity is produced by the photo lamp means 17 substantially simultaneously with the exposure of the aperture 44 by aperture opening 43. However, because no large mass in the form of a permanent magnet is attached to a movable part, the dynamic performance of the apparatus can be improved.

FIG. 8 is a functional block diagram of the construction of the integrated circuit, magnetically sensitive Hall element and integrated circuit amplifier shown at 88 in FIG. 7. The Hall element employed in this structure, is shown at 101 and may comprise a combined metal oxide surface semiconductor Hall element and amplifier of the type described in U.S. Pat. No. 3,524,997, issued Aug. 18, 1970, for a "Monolithic Integrated Phase Control Circuit", John D. Harnden, Jr., et. al., inventors, and assigned to the assignee of the present invention. The Hall element is a well-known magnetically sensitive device having a conducting channel or inversion layer extending between a source and drain electrode. Upon a strong magnetic field on the order of about 2 kilogauss being applied perpendicular to the current flow of the device, it produces through the medium of the well-known Hall Effect, a voltage component which is mutually perpendicular to both the current flow and the magnetic field, and is proportional to the product of the current and the magnetic field. This output voltage is supplied to a suitable signal-shaping circuit 102 which may comprise a field effect transistor amplifier circuit whose output in turn supplies a power amplifier stage 103. The power amplifier stage 103 may itself comprise a device such as a silicon control rectifier (SCR), a PUT, a SUS, or other known power amplifier device and may be directly connected in circuit relationship with the photo lamp means 17 and battery source 15 for controlling electric current flow through the photo lamp means 17 shown in FIG. 7. All of the elements 101, 102 and 103 of the overall circuit structure 88 may be fabricated in monolithic integrated circuit form so as to be readily mounted within the housing of a hand-held camera. For a more detailed description of the construction and operation of the Hall element magnetic sensor and integrated circuit amplifier structure, reference is made to the above-identified U.S. Pat. No. 3,524,997.

FIG. 9 is a schematic illustration of still another form of magnetically triggered, contact-less, light emission initiation control circuit constructed in accordance with the invention. In the embodiment of the invention shown in FIG. 9, a magnetically sensitive semiconductor switch element shown at 105 controls the initiation of light emission from a photo lamp means 17 in the manner described above. For example, the semiconductor switch element 105 may comprise either a magnetically sensitive diode, a magnetically sensitive transistor, such as that described in U.S. Pat. No. 3,389,230, or a magnetically sensitive Hall element together with associated integrated circuit amplifier elements. A rotatable permanent magnet trigger member shown at 106 is positioned over the semiconductor

switch element 105 and includes an aperture opening 43 that is rotated into alignment with an aperture shown in dotted outline form at 44, upon the rotatable member 106 being rotated in a counterclockwise direction as shown by the arrows. The release mechanisms and spring drive mechanism for rotating member 106 are not shown for purposes of simplifying the description. The rotatable trigger member 106 includes a pole piece 107 which upon being aligned with a coating pole piece 108 disposed adjacent the semiconductor switch element 105, causes the semiconductor switch element to be triggered to its conducting condition as described previously. In the arrangement shown in FIG. 9, however, the linear position of pole piece 108 is physically adjustable to different locations such as shown in dotted outline form at 108a whereby the particular point at which the semiconductor switch element 105 is triggered into conduction relative to the angular position of the aperture 43 with respect to the aperture 44, can be adjusted physically by a user of the flash initiation control circuit. This can be achieved by a simple sliding support for the pole piece 108 which is calibrated in terms of time delay so as to achieve either minimum or maximum delay of the light emission relative to the alignment of the aperture opening 43 over the aperture 44. By this means, the user of the camera can control to a greater degree the timing relation between the pulsed maximum intensity light output from the photo lamp means 17 relative to the opening of the aperture of the camera.

FIGS. 10 and 11 of the drawings illustrate still another form of the invention wherein by suitable fabrication of the semiconductor switch element employed in the arrangement of FIG. 9, and proper disposition of several magnetically sensitive areas on a semiconductor substrate to form a multiple semiconductor switch element such as shown at 111, a selectable built-in time delay can be obtained wherein an operator of a camera can by appropriate choice of an output terminal, achieve any one of a plurality of different time delays relative to the opening of the aperture of the camera. For example, if a semiconductor switch element such as 111 has formed on its substrate three different magnetically sensitive switch areas 112, 113, 114, with each respective area having its own output terminal  $T_1$ ,  $T_2$ , and  $T_3$ , then the output flash initiating signal pulses obtained from each of these areas will have different time delays if the switch element 111 is included in a physical circuit arrangement such as shown in FIG. 9. Thus, with a semiconductor switch element such as 111, no physically movable parts are required to obtain different timed output signal pulses for producing light flashes in different time sequence relative to the opening of the aperture of the camera.

For example, assuming the switch element 111 were inserted physically in the circuit of FIG. 9, it will be seen that as the pole piece 107 is being rotated counterclockwise sequentially scans across the magnetically sensitive switch areas 112, 113, 114 in that order. Thus it will be seen that an electric output signal pulse will be produced at 112 some 10 milliseconds (for example) in advance of the signal pulse produced by the magnetically sensitive switch area 114, and the switch area 113 will produce an output flash initiating signal pulse 2 milliseconds in advance of the pulse produced by the switch area 114. This time relation relative to the opening of the aperture 44 by aperture opening 43

is illustrated in FIG. 11 wherein the light output from a photo lamp triggered by respective ones of the output terminals  $T_1$ ,  $T_2$ , and  $T_3$  is plotted vs. time.

It will be seen in FIG. 11 that if the operator connects the photo lamp means 17 to the output terminal  $T_1$ , the maximum intensity light flash will be produced only about 1 millisecond in advance of the opening of the aperture 44 by aperture opening 43. For certain types of pictures, under certain conditions, this kind of exposure is desirable. However, for other conditions, it may be desirable to connect the photo lamp means 17 to the output terminal  $T_2$  whereby maximum light intensity from the photo lamp would be produced some 2 milliseconds in advance of the opening of the camera aperture. Similarly, by connecting the photo lamp means 17 to the output terminal  $T_3$ , a full 10 millisecond delay can be obtained. The selection of the delay can be made by the operator in advance of taking the picture, and is a fixed highly predictable, reliable time delay since there are no physical adjustments that have to be made by the operator other than connecting the photo lamp means to the desired output terminal  $T_1$ ,  $T_2$ ,  $T_3$ ,  $T_0$ , etc. It should be noted that the particular time delays described are for purpose of illustration only and may be varied to suit particular applications by appropriate modification of the design of the various magnetically sensitive switch areas 112, 113, etc. semiconductor switch element 111 relative to the locations of the pole piece 107 and the aperture opening 43 and aperture 44. In this manner an adaptive or optimum delay can be obtained for cameras having various shutter speeds.

FIG. 12 is a schematic illustration of still another embodiment of the invention wherein built-in time delay may be obtained between two different functions to be controlled by a contact-less flash initiation control circuit constructed in accordance with the invention. In the embodiment of the invention shown in FIG. 12, a photo lamp means 17 is designed to be flashed by controlling electric current flow through the photo lamp means 17 from a source of electric energy such as 15. For this purpose, a magnetically sensitive semiconductor switch element 111 is provided having a first magnetically sensitive switch area 112 connected to control electric current flow through the photo lamp means 17. A second magnetically sensitive semiconductor switch area 113 is formed on element 111 and is connected to control energization or actuation of a relay winding 115 that then in turn controls release or actuation of a rotatable shutter wheel 42 having an aperture opening 43 therein for controlling exposure of the film plane of the camera through the aperture 44 shown in dotted outline form. This arrangement may be similar to that employed on bellows type cameras used for better quality picture taking by professional photographers. With such cameras, it is necessary to provide some remote control means for synchronizing operation of the shutter mechanism located at the end of the bellows when it is in its expanded condition, with the emission of light from a photo lamp such as 17.

With the arrangement shown in FIG. 12, upon the pushbutton 17 being depressed, the field of the permanent magnet 49 will first affect switch area 112 to produce light emission from the photo lamp means 17 due to the closer physical proximity of the magnet causes this switch area first be rendered conductive. Thereafter, as the permanent magnet 49 travels further

inwardly from the position shown due to the continued depression of the pushbutton 47, the strength of the magnetic field influencing the magnetically sensitive switch area 113 will become sufficiently strong to render this switch area conductive. Upon this occurrence, the relay winding 112 controlling the shutter member 42 will be actuated to thereby obtain a synchronized controlled exposure of the film plane to the object being photographed while the light emitted from the photo lamp 17 is at a suitable intensity level.

FIG. 13 is a functional block diagram of a more complete camera control system employing a contact-less light emission initiation control circuit in conjunction with an electrically controlled exposure device. In the embodiment of the invention shown in FIG. 13, a magnetically sensitive light emission initiation circuit is shown at 121 and may be constructed according to any of FIGS. 4 - 12. The magnetic light emission initiation circuit serves to control light emitted from a light source 122 that can comprise a single photo lamp, an array of photo lamps, a flash cube or the like, which emits light when energized from a suitable energy source such as 123 under the control of the magnetically sensitive, contact-less, light emission initiation circuit 121. The energy source 123 may comprise a low voltage battery source, a piezoelectric generator, a spring wound generator, or other type of known small power source. Operation of the magnetically sensitive light emission initiation circuit 121 is under the control of a pushbutton switch 124 that depresses a permanent magnet 125 so as to cause its magnetic field to influence the magnetically sensitive area of the initiation control circuit 121. This occurs upon the pushbutton 124 being depressed so as to bring the permanent magnet 125 from the solid line position shown in FIG. 3 down to the first dotted line position shown at 125a. Upon this occurrence, the magnetically sensitive light emission initiation control circuit 121 will function in the previously described manner to cause the photo lamp means 122 to be energized, and emit light for lighting a subject to be photographed.

Further depression of the pushbutton 124 will cause the permanent magnet 125 to be moved to its second position shown in dotted outline form at 125b where its magnetic field will influence the magnetic sensitive surface of a second magnetic initiation control circuit shown at 126. The magnetic initiation control circuit 126, in place of initiating operation of a photo lamp light source such as 122, instead initiates operation of a conversion circuit of conventional construction. The conversion circuit may be comprised by a push-pull transistor power converter circuit of known construction, a thyristor power circuit using SCRs, SUSs, PUTs, or the like, and operates to convert the direct current energy from source 123 to a different form of direct current energy suitable for application to an electrically controlled exposure element 127.

The electrically controlled exposure element 127 functions as an electrically controlled, combined aperture/shutter and is disposed intermediate a lens 128 and the film plane 129 of the camera with which the control system is used. The electrically controlled exposure element 127 because it operates as a combined shutter/aperture controls both the time of opening, as well as the extent of exposure of the film plane 129 to a subject being photographed through the lens 128. For a more detailed description of the electrically con-

trolled exposure element 127 reference is made to an article entitled "GMO - A New Optical Material" by Professor Terutaro Nakamura of the University of Tokyo appearing in *Technocrat Magazine*, vol. 2, No. 5, 1969, pages 44-46. The device comprises a GMO crystal having ferro-electric properties such that it can be made transparent to light upon the application of a control electric field to its terminals. For a more detailed description of this property, reference is made to the above-identified article. The device does constitute, however, a solid state semiconductor type of device so that it allows substantially the complete camera control system to be fabricated in accordance with integrated circuit manufacturing techniques. The device in its unexcited state will serve to block all light passage between the lens 128 and the film plane 129. However, upon appropriate excitation by an applied direct current electric field, the device can be rendered sufficiently light transmissive to form an image of the subject being photographed on the film plane 129. By controlling the time duration of this direct current exciting field, an appropriate photograph of the image can be obtained. The time duration of the exposure can of course be controlled by appropriate design of the magnetic initiation and conversion circuit 126 to provide the desired exposure time period as depicted in FIG. 13A of the drawings.

In operation, assuming that the camera has been appropriately loaded with unused film, and unused flashbulbs, and has been aligned on a subject to be photographed by a user of the camera, a picture can be recorded in accordance with the following sequence. Depression of the pushbutton 124 first initiates operation of the magnetically sensitive contact-less light emission initiation circuit 121 as to emit light from the photo lens light source 122. This is depicted in the curve shown in FIG. 13A (1) wherein the solid line depicts the electric current pulse supplied by the magnetically sensitive light emission initiation circuit 121 to the photo lamp light means 122, and the dotted line illustrates the intensity of the ensuing light pulse produced as a result of the excitation of the photo lamp light source 122. Continued sequential depression of the pushbutton 124 brings the permanent magnet 125 down to its second dotted line position 125b to thereby initiate operation of the magnetic initiation and conversion circuit 126. This circuit thereafter functions to produce an output electric current pulse having the wave shape shown in FIG. 13A (2) to provide appropriate excitation of the electrically controlled shutter/aperture exposure control element 127. From a comparison of the time relation of the current pulse shown in FIG. 13A(2) to that shown in curve (1), it will be seen that the timed exposure control of the electrically operable exposure control element 127 coincides substantially with the light pulse produced by the photo lamp light source 122.

FIG. 14 is a functional block diagram of an even more complete electronic control system for a camera wherein the required time delays between operation of the several subsystems of the camera is achieved electronically. The control system shown in FIG. 14 also is designed for use with an array of photo lamp means which may be selectively sequentially flashed. The control system shown in FIG. 14 employs a magnetically sensitive, contact-less light emission initiation circuit 121 whose operation is controlled by a permanent mag-

net 125 through the medium of a pushbutton 124. The magnetically sensitive light emission initiation circuit 121 may be fabricated in accordance with the teachings of any of FIGS. 4-12, and operates to supply direct current energy from an energy source 123 to a delay synchronizing circuit 131. The delay synchronizing circuit 131 may be fabricated in accordance with any of the known delay circuit structures, preferably of the interconnected bistable circuit variety so that it is susceptible of manufacture with the monolithic integrated circuit techniques. The delay circuit 131 has one output supplied to control the operation of a photo lamp array control circuit 132. The photo lamp array control circuit then in turn selectively controls the flashing or light emission of a selected one of a plurality of photo lamps comprising the light source 133.

The delay synchronizing circuit 131 also has a second output supplied to a converter circuit 134 which may comprise any known transistor converter circuit, or a SCR, SUS, or other known DC to DC power converter circuit susceptible of fabrication in accordance with integrated circuit techniques. The output from the converter circuit 134 is supplied to the electrically operable, shutter/aperture exposure control element 127 as described previously in connection with FIG. 13.

The integrated circuit converter 134 also has a second control input under the control of a light sensor 135 which is positioned to view and integrate or measure the amount of light to which the film plane 129 is exposed through the medium of the electrically controlled exposure element 127. The output from the sensor 135 then controls turn-off of the IC converter 134 so as to provide a substantially closed loop control of the exposure time of the film plane 129.

In operation, assuming that a camera employing the system of FIG. 14 has been properly conditioned for the taking of a picture, the operator then depresses the pushbutton 124. This results in moving the permanent magnet from the solid line position shown at 125 to the dotted line position at 125a and thereby initiates operation of the magnetically sensitive light emission initiation control circuit 121 in the manner previously described in connection with FIGS. 4-12 to supply energization current to the delay synchronizing circuit 131. Delay synchronizing circuit 131 then supplies a current pulse such as shown in solid form in FIG. 14A(1) to the array control circuit 132 which contains selectively to flash or emit light from a desired one of an array of photo lamps comprising light source 133 as depicted by the dotted line curve shown in FIG. 14A(1). Concurrently with this action, the delay synchronizing circuit 131 supplies a delay energizing pulse to the electrically controlled shutter/aperture exposure element 127 to excite its operation and expose the film plane 129.

The output current pulse supplied from the integrated converter circuit 134 is illustrated by the waveform in FIG. 14A(2). From an examination of FIG. 14A(2) it will be seen that there are a number of different trailing edges 136a, 136b...136f, etc., provided for the current pulse. These different trailing edges depict the manner in which the time duration of the excitation current supplied to the electrically controlled exposure element 127 can be varied in accordance with the setting of the sensor 135 for different film speeds employed at the film plane 129 or as determined by the intensity or level of light of the image being photographed. Thus, if the film employed at the film plane

129 is extremely high speed, or the lighting background, etc. produces a high intensity image, the control pulse supplied to the electrically controlled exposure element 127 may be extremely short in duration such as depicted by the pulses 136a, 136b, etc., to thereby obtain only a very short time duration exposure of the film plane to the subject being photographed. Alternatively, if the film employed is relatively slow in speed, or the background, etc., produces only a very low level intensity image, the time duration of the control pulse to the exposure element 127 may extend out to the point 136f, etc. By this means, closed loop control over the extent of exposure of the film plane to the subject being photographed is positively provided to assure acceptable quality image reproduction at the film plane 129. Because substantially all of the elements of the camera control system shown in FIG. 14 are electronic in nature, the entire system is susceptible to manufacture in integrated circuit form whereby it can be employed in a hand-held camera. Thus, it can be produced and sold at relatively low cost while assuring relatively high quality image production.

FIG. 15 is a schematic circuit diagram of still another different form of contact-less light emission initiation control circuit constructed in accordance with the invention and which employs a light emitting diode and light activated SCR to achieve contact-less light emission initiation. The arrangement shown in FIG. 5 employs a spring wound rotatable shutter plate 42 that automatically is rotated in a counterclockwise direction upon the pushbutton 47 being depressed to release the end of lever arm 46 from the stop 45 upon the user of the camera desiring to snap a picture, all in the manner previously described with relation to FIG. 4 of the drawings. The arrangement further includes a photo lamp means 17 that may comprise a single photo lamp, a flashcube, a linear array of flashbulbs, or an array control circuit selectively controlling desired ones of an array of flash lamps, etc., as described previously. The photo lamp means 17 is designed to be inserted into a pressure socket fitting so that it is self-cleaning by insertion and removal of the photo lamp bulbs. The terminals of the socket for the photo lamp means 17 are connected in series circuit relationship with a source of electric energy 15 that may comprise a battery, piezoelectric generator, etc. The source of electric energy 15 may even comprise an expendable paper battery such as that described by the Norelco Manufacturing Company in recent literature released by that company.

The series circuit comprising by 17 and 15 is connected across a first circuit branch comprised by a light emitting diode 141 (referred to as a LED) connected in series circuit relationship with a limiting resistor 142. The light emitting diode 141 may comprise any conventional, commercially available light emitting diode such as the gallium arsenide diode manufactured and sold by the Miniature Lamp Department of the General Electric Company, a visible light emitting diode of gallium phosphide also manufactured and sold by the Miniature Lamp Department of the General Electric Company, and other such similar devices. Light emitted by the light emitting diode 141 is intended to pass through an initiating opening 143 formed in the rotatable shutter member 142 upon the opening 143 becoming aligned with an opening 144 in a stop. Light transmitted from the light emitting diode 141 through openings 143 and 144 will impinge upon the light sensitive sur-

face of a light activated silicon control rectifier 145 (referred to as a LASCR).

The LASCR is a conventional, commercially available device manufactured and sold by the Semiconductor Products Department of the General Electric Company and may be fabricated in either discrete or integrated circuit form, and constitutes a second circuit branch connected in parallel with the circuit branch comprised by LED 141 and limiting resistor 142. With the circuit arrangement thus comprised, the photo lamp 17 serves as an on-off switch in the manner of an electric fuse and requires that the bulb not be placed in the terminal until such time that the camera is ready for use. Thus, while the circuit is stored on a shelf, etc., between periods of use, the flashbulb should not be inserted in its receiving socket. When it is desired to take a picture, the photo lamp 17 is inserted in the receiving socket thereby conditioning the circuit for the taking of a picture. It will be noted, that when thus conditioned, a closed circuit is produced through the circuit branch including the LED 141. This device is designed to draw a current of about 0.01 ampere which is so small as not to constitute a serious drain on the battery source 15 while the user of the camera is otherwise occupied in aiming, etc., the camera. However, it is necessary that the photo lamp 17 be of the variety that includes a filament for supplying the required 0.01 ampere excitation current to LED 141.

When it is desired to take a picture, the pushbutton 47 is released thereby releasing the spring driven rotatable shutter member 42. As stated above, the LED 141 already has been energized so that it is emitting light which under prior conditions has been blocked by the rotatable shutter plate 42. Upon the shutter plate rotating the two openings 143 and 144 into alignment, light from LED 141 passes through and impinges upon the light sensitive surface of the LASCR 145. This results in rendering LASCR 145 conductive and supplying current of sufficient magnitude to ignite the photo lamp 17. For this purpose, it is necessary that the photo lamp 17 be of the filamentary type so that sufficient trickle current can be supplied through it to energize the low current LED 141 without flashing the photo lamp. Thereafter, the aperture opening 43 in the shutter plate will be brought into alignment with the aperture 44 of the camera due to continued rotation of the shutter plate 42 in the previously described manner. This will result in exposing the film plane of the camera substantially concurrently in time with the production of the light pulse by the photo lamp 17.

The voltage vs. time characteristic curve to the right of FIG. 15 illustrates the voltage characteristics of an expendable paper battery of the type described by the Norelco Company. It will be noted that this type of battery must be activated by the user by squashing a suitable electrolyte fluid vial in advance of using the expendable paper battery as an energy source. Following the squashing of the electrolyte vial, voltage across the battery will rise substantially in the manner shown by the characteristic curve shown in FIG. 15. At some point indicated by the dotted line, thereafter, the system of FIG. 15 may safely be employed by the user of the circuit to take reliable flash pictures, and he will be assured of an adequate energy source to operate the system in the manner described above. It should be further noted that following the flashing of the photo lamp 17 it will become open-circuited in the manner of an

electric fuse so that a further drain on the battery does not occur until the new bulb is placed in the light socket to thereby condition the system to take a new picture. This operation would be carried out by user of the camera along with pre-winding the rotatable shutter member 42 to condition it for the taking of a new picture.

Should it be desired, the contact-less light-emission control circuit shown at 15 could be modified by replacing the light emitting diode 141 and limiting resistor 142 with an alpha particle source such as that shown in dotted outline form at 146. With the control thus modified, it is essential that the rotatable shutter member 42 or other shielding member be fabricated of a material which will shield the film at the film plane of the camera from alpha particle radiation from the source 146. In operation, the circuit will function in substantially the same manner as described earlier with relation to the LED version of FIG. 15, with the exception that the alpha particle source 146 now constitutes the source of initiating radiation that is directed onto the radiant energy sensitive surface of the LASCR 145 upon the openings 143 and 144 coming into alignment. Otherwise, the control circuit would function in substantially the same manner as described in the preceding paragraphs.

FIG. 16 is a schematic circuit diagram of an embodiment of the invention which was built employing an Eastman Kodak Model 134 Instamatic camera modified to include a contact-less light emission initiation control circuit shown in FIG. 16. The circuit elements employed in FIG. 16 are substantially identical to those described in connection with FIG. 5 of the drawings, and hence will not be again described in detail. The only difference between the FIG. 16 circuit and that shown in FIG. 5 is the substitution of a light emitting diode 141 for the magnetically sensitive diode 41 used in FIG. 5, and the substitution of a light activated SCR 145 for the conventional gate controlled SCR 18 and its associated gate control circuitry. Another distinction of importance is the inclusion of the additional initiating openings 143 in the rotatable shutter member 42 and the additional opening 144 in a back plate (not shown) but depicted by dotted outline form in FIG. 16. These additional apertures serve to time or synchronize the exposure of the LASCR 145 to light emitted from the light emitting diode 141 as described previously in connection with FIG. 15 of the drawings.

The particular trigger mechanism that was employed to trigger the shutter plate is the same as that shown in FIG. 6 of the drawings and described previously in connection with FIG. 5. The trigger mechanism of FIG. 6 when used with the light activated system of FIG. 16 is modified to remove the permanent magnet previously described and insert instead the two openings 143 and 144 to allow for timed passage of light between the LED 141 and the LASCR 145 (not shown in FIG. 6 of the drawings). In all other respects, the trigger mechanism was constructed and operates in substantially the same manner as described previously in connection with FIG. 6, and is substantially the same as that employed in a Model 134 Instamatic camera.

Briefly, however, it will be seen that upon placing the camera control system of FIGS. 16 and 6 in operation, depression of the pushbutton 47 will release the amplifying arm 71 for movement counterclockwise from its dotted line position to its solid line position shown in

FIG. 6. Upon this occurrence, the amplifying arm 71 sweeps across the lever arm 67 causing the shutter plate 61 to rotate clockwise thereby opening or exposing the aperture opening 44. Prior to this occurrence, in the sequence of events, the additional opening 143 in the rotatable plate 69 will have swept across the additional opening 144 thereby allowing light emitted from diode 141 to impinge upon the light sensitive surface of the LASCR 145. This renders LASCR 145 conductive and initiates light emission from a photo lamp (not shown) connected to the terminals 17a, 17b shown in FIG. 16. This light emission is timed to occur substantially simultaneously with the maximum opening of the aperture 44 by the shutter plate 61. The extent (diameter) of the optical path provided through the aperture opening 44 is controlled by the exposure control 51 in accordance with the ambient light level as is well-known in the art. The time duration of the opening of the aperture 44 will of course be controlled by the time required for the return spring 65 to return the shutter plate 61 to its normal, quiescent position shown in solid line in FIG. 6. It will be appreciated therefore, that the light activated embodiment shown in FIGS. 16 and 6 functions in substantially the same manner as the magnetically controlled embodiment to perform contact-less light emission initiation from a photo lamp lighting means.

FIG. 6A of the drawings illustrates a modification of the embodiment of the invention shown in FIGS. 16 and 6. In the alternative arrangement of FIG. 6A, a highly reflective surface shown at 149 is formed on the shutter plate 61 and is located in a position such that it will reflect light past a stop 148 from the light emitting diode 141 to the light sensitive surface of the LASCR 145 at a particular point in the angular travel of shutter member 61 where it is desired to render the LASCR 145 conductive. By thus modifying the arrangement of FIGS. 16 and 6, it no longer becomes necessary to cut the openings 143 and 144 in the trigger mechanism shown in FIG. 6. This simplifies the manufacture of the assembly, as well as relaxes some of the requirements on the location of the LASCR 145 and LED 141. Additionally, because only the formation of a light reflecting surface 149 is required, no substantial mass is added to the shutter mechanism 61 thereby enhancing its performance. Further, it might be noted that the provision of the low mass, light reflective shutter member light emission initiation shown in FIG. 6A, and similar arrangements described herein allows a designer of a camera shutter trigger mechanism to go to direct acting shutter arrangements in contrast to indirect acting shutter trigger mechanisms. This is due to the fact that the trigger mechanism will now no longer be required to actuate auxiliary electrical contacts or other similar tasks which impose a mechanical loading on the trigger mechanism. The result is to greatly simplify the task of the designer of the trigger mechanism as well as to allow for improved performance of the mechanism.

FIG. 17 is a schematic circuit diagram of a different form of light activated, contact-less light emission initiation circuit for use with a camera control of the type having an on-off switch 16 that is normally closed and maintained closed after the taking of a picture. With such on-off control switch design, it can be seen that the circuit arrangement of FIGS. 15 and 16 would maintain a continuous current drain on the battery source 15 so as to run down the source during periods

of non-use. To avoid this from happening, a capacitor 151 is inserted in the circuit branch between the light emitting diode 141 and the limiting resistor 142. In this arrangement, the LASCR 145 again is connected through the photo lamp 17 in parallel with the circuit branch including the light emitting diode 141 across the battery source 15. Here again the photo lamp 17 will serve as an on-off fuse for discontinuing conduction through the LASCR 145 after being flashed, and a new bulb must be inserted in the circuit by the user in order to condition it for re-use.

With the circuit arrangement of FIG. 17, prewinding or cocking of the trigger mechanism of the camera will automatically open the switch 16. However, due to the fact that the switch 16 previously was closed on its fixed contact, the capacitor 151 will have been charged to the full voltage of the battery source 15. Assuming that there is a fresh flashbulb 17 in the circuit, then upon closure of switch 16 by the user of the camera, sufficient energy will be discharged from the capacitor 151 through LED 141 to initiate light emission and selectively activate the light activated SCR 145. This results in turning on LASCR 145 and flashing the flashbulb 17. The light output vs. time characteristic curve shown to the right in FIG. 17 illustrates the light output characteristic of the LED 141. It can be seen that by appropriate design location of the exposure openings of the camera (not shown) relative to the energization of the LED 141 at a point such as shown by the dotted line, synchronized, contact-less light emission initiation can be obtained with the circuit of FIG. 17. Further, because the switching mechanism of the camera is of the type wherein the contacts 16 remain closed after use, the inclusion of the capacitor 151 will prevent further current drain on the battery source 15 after it has once become charged to the voltage of the battery.

From the foregoing description, it will be appreciated that the present invention provides a family of new and improved contact-less light emission initiation circuits for use in controlling operation of photo lamps, flashbulbs, flash cubes, lamp arrays, etc., employed in lighting subjects to be photographed with a camera. The contact-less photo lamp light emission initiation circuits may be fabricated in micro-miniaturized integrated circuit form, are capable of reliable operation even with low voltage electric energy sources, such as expendable paper batteries, and the like, and may be included as an operating subsystem of an over-all camera control system for controlling light emission together with other controlled functions such as controlled exposure of the film plane of the camera, etc.

Having described several embodiments of a new and improved contact-less, light emission initiation circuit for camera control systems constructed in accordance with the invention, it is believed obvious that other modifications and variations of the invention are possible in the light of the above teachings. It is, therefore, to be understood that changes may be made in the particular embodiments of the invention described which are in the full intended scope of the invention as defined by the appended claims.

What I claim as new and desire to secure by Letters Patent of the United States is:

1. A contact-less photo lamp flashing circuit comprising electric supply terminal means for connection to a source of electric energy and to photo lamp means to initiate light emission from the same upon the establish-

ment of a closed electric current path through the electric supply terminal means, the source of electric energy and the photo lamp means to be energized, semiconductor switch means connected in the current path intermediate the photo lamp means and source of electric energy for controlling the closure of the current path to the photo lamp means, said semiconductor switch means being provided with a control electrode for selectively rendering said semiconductor switch means conductive, a magnetically sensitive semiconductor device and a load resistor connected in series across said electric supply terminal means, means coupling said control electrode of the semiconductor

switch means to the junction of said device and load resistor, and magnetic means to impress a magnetic field on said magnetically sensitive semiconductor device in synchronism with the opening of a camera shutter, said magnetically sensitive semiconductor device being provided with a plurality of individual magnetically sensitive areas, said magnetic means being adapted to impress said magnetic field on said magnetically sensitive areas in time sequence, and including means for selectively connecting any of said magnetically sensitive areas in series with said load resistor for achieving flash synchronization.

\* \* \* \* \*

15

20

25

30

35

40

45

50

55

60

65