

No. 863,473.

PATENTED AUG. 13, 1907.

L. D. TOLIVER.
DISK SHARPENER.
APPLICATION FILED NOV. 26, 1906.

2 SHEETS—SHEET 1.

Fig. 1.

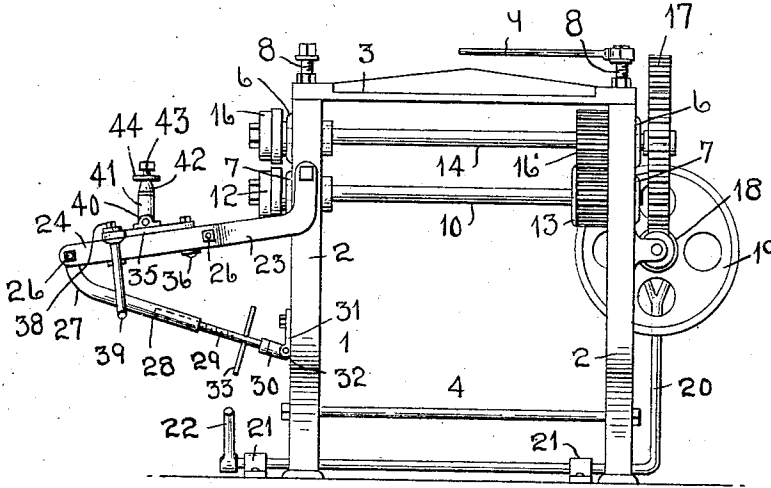
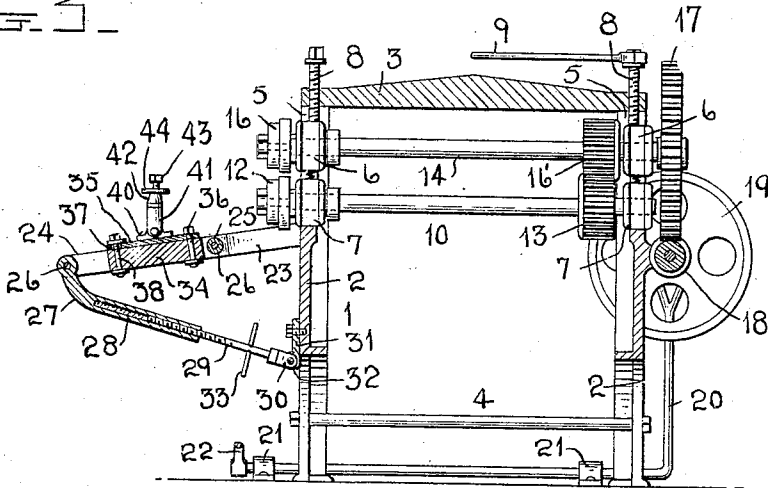

Fig. 2.



Witnesses
L. B. James
C. H. Giesbauer

Inventor
Lorenzo D. Toliver

By *A. B. Wilson*
Attorneys

No. 863,473.

PATENTED AUG. 13, 1907.

L. D. TOLIVER.
DISK SHARPENER.
APPLICATION FILED NOV. 26, 1906.

2 SHEETS—SHEET 2.

Fig. 2.

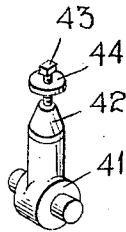
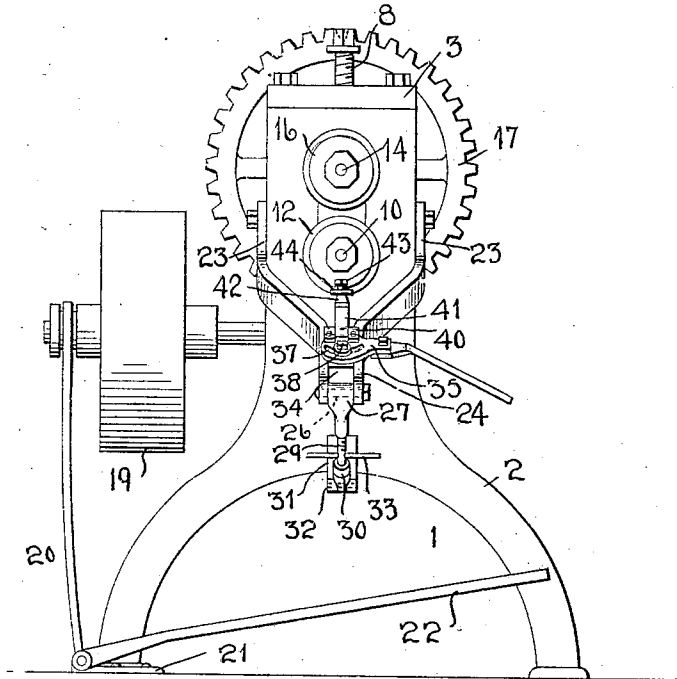
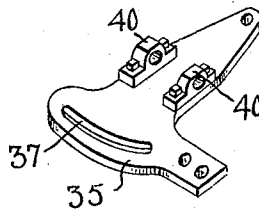

Fig. 4.

Fig. 5.



Witnesses
L. B. James
C. H. Griesbauer

Inventor
Lorenzo D. Toliver

By *A. B. Wilson & Co.*
Attorneys

UNITED STATES PATENT OFFICE.

LORENZO D. TOLIVER, OF ABILENE, KANSAS.

DISK-SHARPENER.

No. 863,473.

Specification of Letters Patent.

Patented Aug. 13, 1907.

Application filed November 26, 1906. Serial No. 345,143.

To all whom it may concern:

Be it known that I, LORENZO D. TOLIVER, a citizen of the United States, residing at Abilene, in the county of Dickinson and State of Kansas, have invented certain new and useful Improvements in Disk-Sharpener; and I do declare the following to be a full, clear, and exact description of the invention, such as will enable others skilled in the art to which it appertains to make and use the same.

This invention relates to improvements in roller disk sharpening machines.

The object of the invention is to provide a device of this character having means whereby a disk may be adjustably supported in position thereon to be engaged by the sharpening rolls and means whereby the supporting device for the disks may be raised or lowered to vary the angles of inclination at which the disk is held.

A further object is to provide a machine of this character having means whereby the pressure of the sharpening rolls upon the disk may be regulated.

With the above and other objects in view, the invention consists of certain novel features of construction, combination and arrangement of parts, as will be hereinafter described and claimed.

In the accompanying drawings:—Figure 1 is a side view of the disk sharpener constructed in accordance with the invention; Fig. 2 is an end elevation of the same; Fig. 3 is a vertical sectional view; Fig. 4 is an enlarged detail view of the disk supporting spindle; and Fig. 5 is a similar view of the adjustable supporting plate.

Referring more particularly to the drawings, 1 denotes the supporting frame of the machine, which consists of end pieces 2 connected together at their upper ends by a cross plate 3 and at their lower ends by tie-rods or bars 4. In the upper portion of the end pieces 2 are formed vertically-disposed recesses 5, in which are arranged upper and lower pairs of journal boxes 6 and 7. The lower pair of journal boxes 7 are stationary while the upper pair of boxes 6 are adapted to be adjusted vertically by means of bolts 8 that are screwed through apertures in the top cross plate 3, as shown. The bolts 8 are provided with squared heads, with which is adapted to be engaged a wrench 9, by means of which the bolts 8 are screwed in or out to adjust the boxes 6.

Journalled in the lower stationary boxes 7 is a longitudinally-disposed shaft 10, one end of which projects beyond the box at one end of the machine, and has fixedly mounted thereon a lower sharpening roller 12. On the shaft 10 adjacent to the inner side of the opposite end plate is mounted a spur gear pinion 13. Journalled in the upper pair of boxes 6 is an upper sharpening roll shaft 14, one end of which projects beyond the end of the machine, and has fixedly mounted thereon an upper

sharpening roller 16. The roller 16 is disposed immediately above the roller 12, and is adapted to be brought into engagement therewith. On the opposite end of the shaft 14 is mounted a spur gear pinion 16' adapted to mesh with the pinion 13 on the lower shaft to operate or drive the same.

The end of the upper shaft 14 opposite to that having the sharpening roller projects beyond the opposite side of the frame, and has fixedly mounted thereon a worm gear 17 adapted to be engaged and driven by a worm 18 journalled in suitable bearings on the end of the frame. On the shaft of the worm 18 is mounted a friction clutch pulley 19, by means of which the machine is connected with and operated by any suitable driving mechanism. The clutch pulley 19 is adapted to be drawn into and out of operative connection with the worm shaft by means of a right angularly formed, shifting lever 20, which is journalled in suitable bearings 21, and is provided on one end with a laterally-projecting handle 22 by means of which the same is operated.

On the end of the frame opposite to that on which the drive mechanism is arranged is pivotally-mounted a disk supporting mechanism, said mechanism being here shown as consisting of a pair of supporting arms or bars 23, the inner ends of which are bent upwardly at right angles and are pivotally connected to the opposite edges of the end of the frame. The arms 23 project forwardly from the end of the frame and are bent or converge toward each other to form parallel supporting bars 24. These bars 24 are spaced apart by spacing blocks 25, and are bolted together by clamping bolts 26. Pivotaly-connected to the forward ends of the bars 24 is the upper curved end of an adjustable supporting brace 27, the opposite end of which is provided with a threaded bore 28. In the bore 28 is adapted to be screwed the threaded outer end of an adjusting screw 29, the inner end of which is provided with a socket 30 by means of which said inner end of the screw is revolubly-mounted upon a supporting post 31, which is hingedly connected to the lower portion of the end of the frame, as shown at 32. The screw 29 is provided with a transversely-disposed operating rod 33, by means of which said screw may be readily turned to increase or diminish the length of the brace 27, thereby raising or lowering the supporting arms 23 and bars 24 to vary the angle of the disk supported thereon.

Adjustably-mounted between the bars 24 is a block or carriage 34, on which is pivotally-mounted a disk supporting plate 35. The plate 35 is pivotally-connected at its inner end to the block 34, by means of a pivot bolt 36. The opposite end of the plate 35 is provided with a segmental slot 37, through which is arranged a clamping bolt 38, by means of which the plate

may be locked at any desired angle when turned upon the pivot bolt 36. The plate 35 is also provided with a handle 39, by means of which the same may be readily turned or swung in one direction or the other.

- 5 Hingedly-mounted upon the plate 35 in suitable bearings 40 is a disk supporting post 41 having a frusto-conical upper end 42 adapted to be inserted through the central aperture of the disk when arranged thereon. The upper end of the post 41 is provided with a threaded socket, into which is adapted to be screwed a clamping bolt 43. On the clamping bolt 43 is arranged a clamping plate or washer 44 adapted to engage the outer side of the disk, thereby firmly holding the same in position on the post 31.
- 10 15 By arranging the supporting plate and post of the disk upon an adjustable block or carriage, said plate and post may be shifted to accommodate disks of various sizes, and by pivotally-mounting the plate 35 upon said block or carriage the disk may be swung to the proper position for engaging the edge thereof with the sharpening rollers. The proper angles for supporting the disk may be readily obtained by turning the adjusting screw 29 in one direction or the other to lengthen or shorten the supporting brace 27. By 25 means of the bolts 8, the upper journal boxes may be adjusted to regulate the pressure of the upper sharpening roll on the disk.

From the foregoing description, taken in connection with the accompanying drawings, the construction and operation of the invention will be readily understood without requiring a more extended explanation.

30 Various changes in the form, proportion and the minor details of construction may be resorted to without departing from the principle or sacrificing any of the advantages of this invention, as defined by the 35 appended claims.

Having thus described my invention, what I claim as new and desire to secure by Letters-Patent, is:—

1. A disk sharpening machine comprising a frame, sharpening rolls revolubly mounted on said frame, a pair of supporting arms pivotally mounted on said frame, means to adjustably support said arms at different angles relatively to said rolls, and a disk holding post mounted to swing laterally and slide longitudinally relatively to said rolls. 40 45

2. A disk sharpening machine comprising a frame, sharpening rolls mounted to rotate on said frame, a pair of supporting arms pivotally mounted on said frame, an adjustable brace rod to support said arms at different angles with respect to said rolls, and a hinged disk holding post mounted to slide longitudinally and swing laterally on said arms, substantially as described. 50 55

3. A disk sharpening machine comprising a frame, sharpening rolls mounted to rotate on said frame, a pair of supporting arms pivotally mounted on said frame, an adjustable brace rod to support said arms at different angles with respect to said rolls, a plate pivotally and adjustably mounted on said arms, and a disk holding post hingedly mounted on said plate eccentrically of the pivot, substantially as described. 60 65

4. A disk sharpening machine comprising a frame, stationary and adjustable coacting sharpening rolls mounted for rotation in said frame, a pair of pivotally-mounted disk supporting arms, a brace bar to support the outer end of said arms, said bar having an interiorly-threaded bore in its lower end, a swiveled adjusting screw adapted to work in said threaded end of the brace bar, whereby the latter may be lengthened or shortened to adjust said arms, a sliding block or carriage on said arms, a plate pivotally mounted on said block, a handle to shift said plate, a disk supporting post hingedly mounted on said plate, and means to secure a disk on said post, substantially as described. 70

In testimony whereof I have hereunto set my hand in presence of two subscribing witnesses.

LORENZO D. TOLIVER.

Witnesses:

EMMA PARENT,
CHAS. W. GANS.