

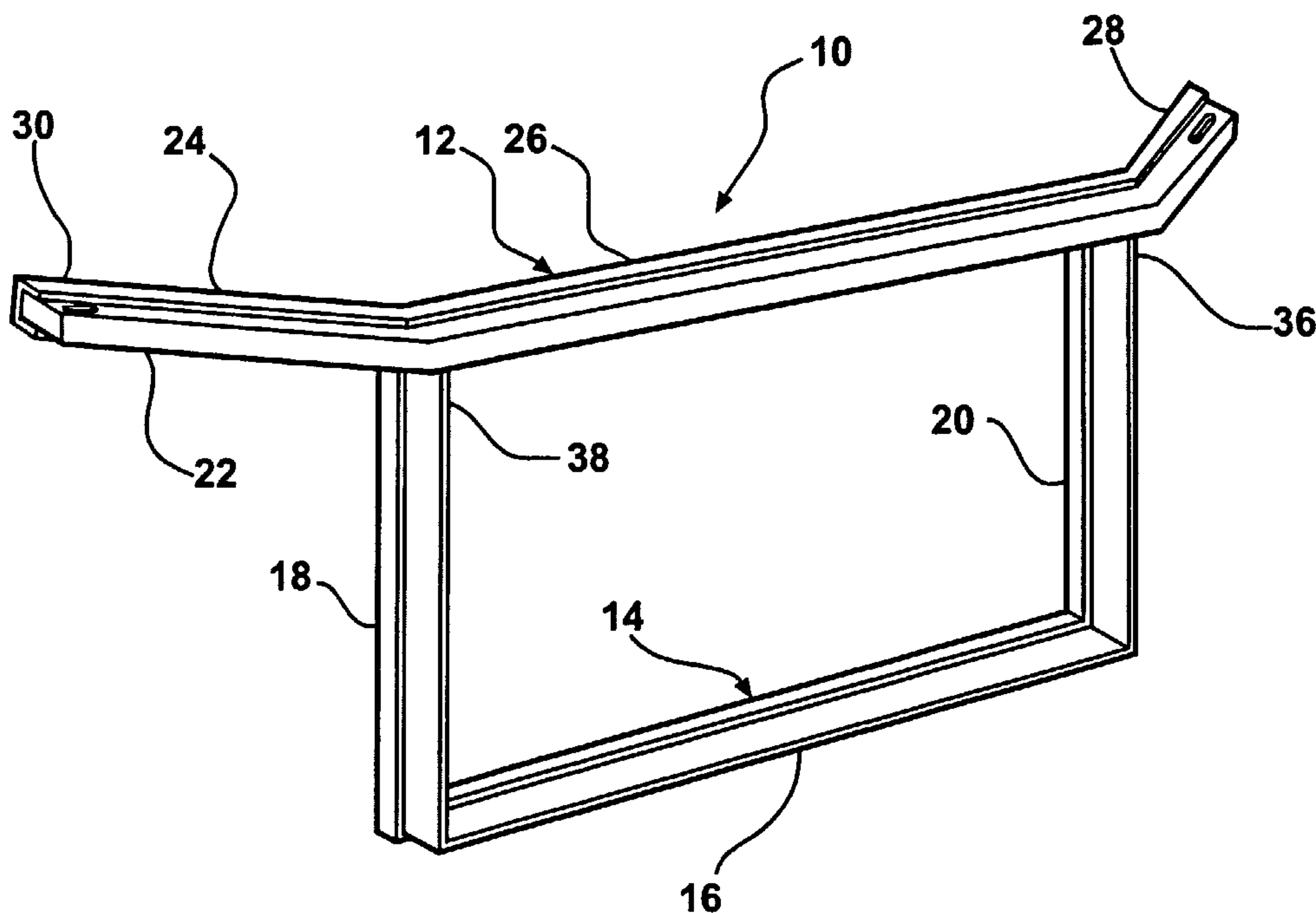

(86) Date de dépôt PCT/PCT Filing Date: 2002/07/18
 (87) Date publication PCT/PCT Publication Date: 2003/01/30
 (85) Entrée phase nationale/National Entry: 2004/01/19
 (86) N° demande PCT/PCT Application No.: CA 2002/001095
 (87) N° publication PCT/PCT Publication No.: 2003/008256
 (30) Priorités/Priorities: 2001/07/18 (60/306,331) US;
 2001/10/15 (60/329,366) US

(51) Cl.Int.⁷/Int.Cl.⁷ B62D 25/08, B60K 11/04, B62D 29/04,
 B62D 29/02, B62D 65/00
 (71) Demandeur/Applicant:
 DECOMA INTERNATIONAL INC., CA
 (72) Inventeurs/Inventors:
 HENDERSON, JACK V., US;
 HOUTARI, KEIJO J., US;
 SCHULTZ, JOHN, US;
 CHUBA, CHARLES JOHN, US
 (74) Agent: IMAI, JEFFREY T.

(54) Titre : PANNEAU D'INTEGRATION DE COMPOSANTS COMPOSITES
 (54) Title: COMPOSITE COMPONENT INTEGRATION PANEL FOR A MOTOR VEHICLE



(57) Abrégé/Abstract:

A panel assembly (10) is securable to a front end of a motor vehicle for positioning and securing a plurality of elements thereto. The panel assembly has a core (22) connectable to the front end of a motor vehicle. A skin (24) covers the core (22). A component mounting structure is molded to the skin (24). The component mounting structure is adapted to have the plurality of elements attached thereto in spaced relation. The panel assembly (10) may be assembled to the motor vehicle with the plurality of elements secured thereto.

(12) INTERNATIONAL APPLICATION PUBLISHED UNDER THE PATENT COOPERATION TREATY (PCT)

(19) World Intellectual Property Organization
International Bureau(43) International Publication Date
30 January 2003 (30.01.2003)

PCT

(10) International Publication Number
WO 03/008256 A1(51) International Patent Classification⁷: **B62D 25/08**,
65/00, 29/02, 29/04, B60K 11/04

(21) International Application Number: PCT/CA02/01095

(22) International Filing Date: 18 July 2002 (18.07.2002)

(25) Filing Language: English

(26) Publication Language: English

(30) Priority Data:
60/306,331 18 July 2001 (18.07.2001) US
60/329,366 15 October 2001 (15.10.2001) US(71) Applicant (for all designated States except US): **DE-COMA INTERNATIONAL INC.** [CA/CA]; 50 Casmir Court, Concord, Ontario L4K 4J5 (CA).

(72) Inventors; and

(75) Inventors/Applicants (for US only): **HENDERSON,****Jack, V.** [US/US]; 6118 Dunmore Dr., WestBloomfield, MI 48322 (US). **HOUTARI, Keijo, J.** [CA/US]; 12434 Orchardwood, Fenton, MI 48430 (US). **SCHULTZ, John** [IE/US]; 20336 Cedar, St. Clair Shores, MI 48081 (US). **CHUBA, Charles, John** [US/US]; 34634 Bunker Hill, Farmington Hills, MI 48331 (US).(74) Agent: **IMAI, Jeffrey, T.**; Magna International Inc, 337 Magna Drive, Aurora, Ontario L4G 7K1, L4G 7K1 (CA).(81) Designated States (*national*): AE, AG, AL, AM, AT, AU, AZ, BA, BB, BG, BR, BY, BZ, CA, CH, CN, CO, CR, CU, CZ, DE, DK, DM, DZ, EC, EE, ES, FI, GB, GD, GE, GH, GM, HR, HU, ID, IL, IN, IS, JP, KE, KG, KP, KR, KZ, LC, LK, LR, LS, LT, LU, LV, MA, MD, MG, MK, MN, MW, MX, MZ, NO, NZ, OM, PH, PL, PT, RO, RU, SD, SE, SG, SI, SK, SL, TJ, TM, TN, TR, TT, TZ, UA, UG, US, UZ, VN, YU, ZA, ZM, ZW.(84) Designated States (*regional*): ARIPO patent (GH, GM, KE, LS, MW, MZ, SD, SL, SZ, TZ, UG, ZM, ZW), Eurasian patent (AM, AZ, BY, KG, KZ, MD, RU, TJ, TM),

[Continued on next page]

(54) Title: COMPOSITE COMPONENT INTEGRATION PANEL FOR A MOTOR VEHICLE

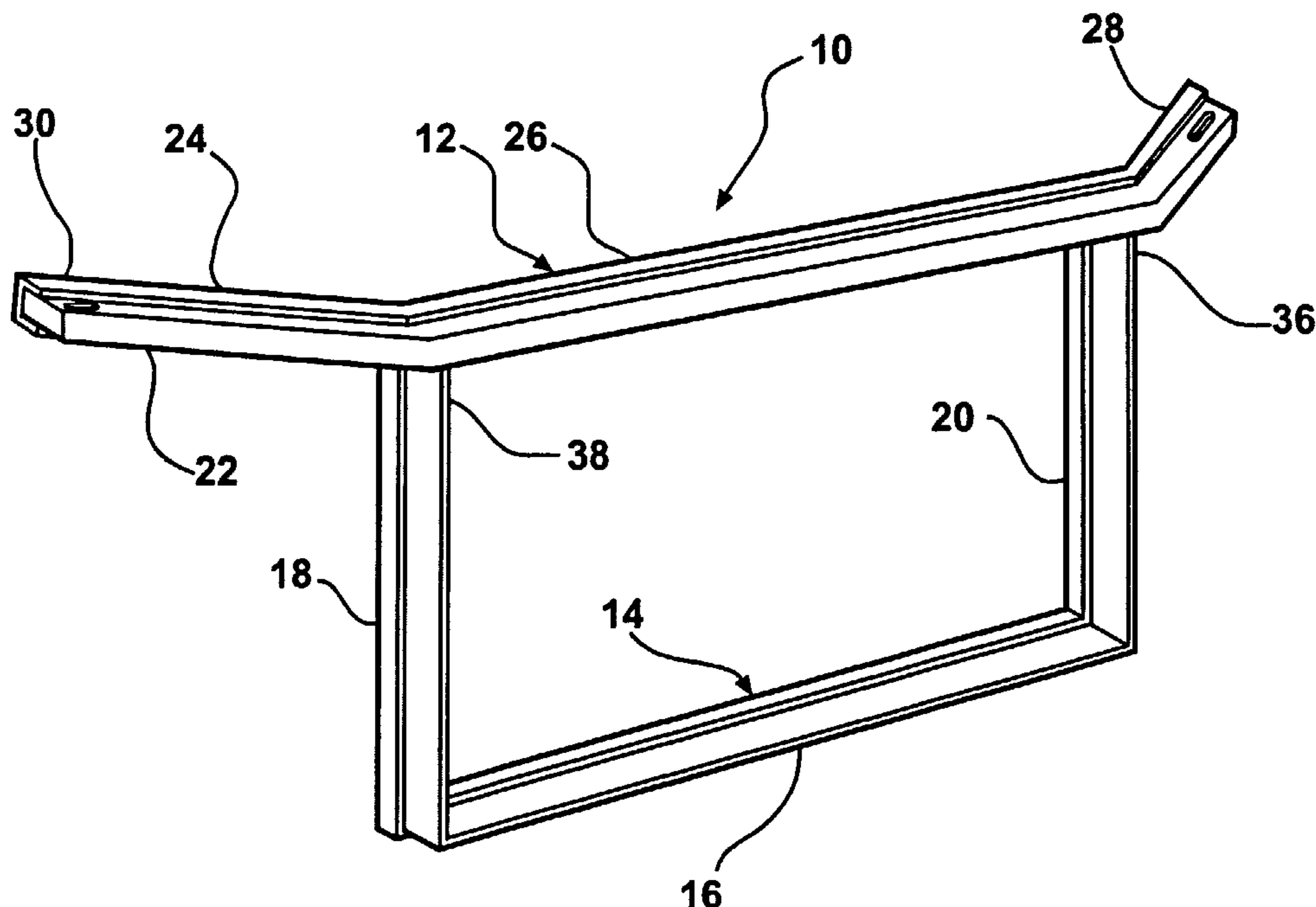

(57) Abstract: A panel assembly (10) is securable to a front end of a motor vehicle for positioning and securing a plurality of elements thereto. The panel assembly has a core (22) connectable to the front end of a motor vehicle. A skin (24) covers the core (22). A component mounting structure is molded to the skin (24). The component mounting structure is adapted to have the plurality of elements attached thereto in spaced relation. The panel assembly (10) may be assembled to the motor vehicle with the plurality of elements secured thereto.

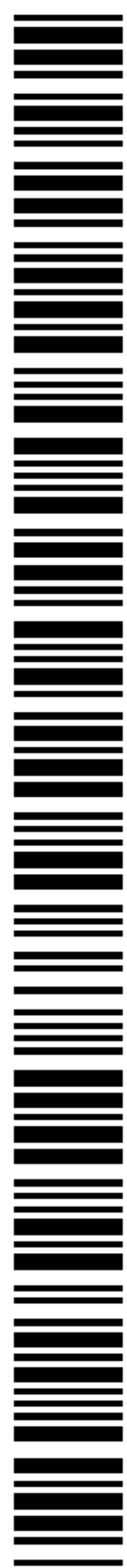

WO 03/008256 A1

WO 03/008256 A1



European patent (AT, BE, BG, CH, CY, CZ, DE, DK, EE, ES, FI, FR, GB, GR, IE, IT, LU, MC, NL, PT, SE, SK, TR), OAPI patent (BF, BJ, CF, CG, CI, CM, GA, GN, GQ, GW, ML, MR, NE, SN, TD, TG).

For two-letter codes and other abbreviations, refer to the "Guidance Notes on Codes and Abbreviations" appearing at the beginning of each regular issue of the PCT Gazette.

Published:

— *with international search report*

COMPOSITE COMPONENT INTEGRATION PANEL

Field of the Invention

The invention relates to a composite component integration panel for an automotive vehicle. More particularly, the invention relates to a front end assembly
5 of a motor vehicle that integrates automotive components typically found in a forward section of a motor vehicle.

Description of the Related Art

A grille opening reinforcement (GOR) is one of the most important
10 components of the front end of an automobile. A GOR is a molded piece having a Class "B" surface, i.e., a surface that is not visible when the motor vehicle is fully assembled. Components such as fenders, bumper covers, grilles, headlamps and the like are assembled to the GOR. The GOR provides attachments, locators and structural support to the components that are secured thereto. It also provides access
15 for lamp bulb replacement, secondary hood latch release levers, and other maintenance and repair requirements.

The primary function of a GOR is to provide the assembly plants a controlled and predictable front-end composite structure for their vehicles. An original equipment manufacturer (OEM) typically incorporates the GOR into all of its designs
20 because the fit and finish of all front-end exterior components are maintained at a high level with great precision. However, a disadvantage of GOR designs is that much of the structure of the GOR is duplicated by a similar structure, namely, the radiator support.

Summary Of The Invention

25 Accordingly, a panel is provided for front-end structure, crash management, and attaching components to a front end of a vehicle body. The panel eliminates duplication of structure between a conventional radiator structure and the GOR. The panel could be installed in either a body shop or trim line application. The trim line

application would allow for additional component integration. For example, parts such as headlamps, park turn lamps, grille, radiator, fascia, fluid reservoirs, and air dams could first be assembled to the panel, thus forming a front-end module, which would then be attached to the body structure. Therefore, the panel would not have an
5 impact on a traditional body shop build but more importantly would have the flexibility of added part consolidation.

Brief Description Of The Drawings

Advantages of the invention will be readily appreciated as the same becomes
10 better understood by reference to the following detailed description when considered in connection with the accompanying drawings, wherein:

Figure 1 is a perspective view of a first embodiment of the invention;

Figure 2 is a perspective view of the first embodiment of the invention
in complete form;

15 Figure 3 is a partially cut-away perspective view of the first embodiment of the invention;

Figure 4 is a partially cut-away perspective view of a second embodiment of the invention;

20 Figure 5 is a partially cut-away perspective view of a third embodiment of the invention;

Figure 6 is a partially cut-away perspective view of a fourth embodiment of the invention;

Figure 7 is a perspective view of a fifth embodiment of the invention;
and

25 Figure 8 is a perspective view of the fifth embodiment of the invention in complete form.

Detailed Description Of The Preferred Embodiments

As shown in the Figures, wherein like primed numerals represent similar elements in different embodiments, a panel assembly of the present invention is generally indicated at 10. The panel assembly 10 is an open structural frame having an upper section 12 and a lower section 14. The lower section 14 includes a cross member 16 and two side members 18, 20 creating a U-shape. Each of the upper 12 and lower 14 sections has a core 22 and a skin 24. In the preferred embodiment, the core 22 is fabricated from balsa wood and the skin 24 is fabricated from a fiber resin matrix, such as a carbon fiber. The balsa wood core 22 is inserted into a mold, which is subsequently shot with the carbon fiber. The carbon fiber skin 24 is applied to the balsa core 22 and serves as a tensile member in impact situations.

The upper section 12 defines a length 26 that extends between a driver end 28 and a passenger end 30. The length 26 extends through a non-linear path in the preferred embodiment. Each of the driver 28 and passenger 30 ends include joint connections 32, 34, best seen in Figure 7. The joint connections 32, 34 will be discussed in greater detail subsequently.

The lower section 14 extends between an upper driver end 36 and an upper passenger end 38. More specifically, one 20 of the side members 18, 20 ends at the upper driver end 36 and the other 18 of the side members 18, 20 ends at the upper passenger end 38. The upper driver 36 and passenger 38 ends are fixedly secured to the length 26 of the upper section 12 between the driver 28 and passenger 30 ends thereof.

As detailed in Figure 3, the carbon fiber skin 24 is shaped in a partial C-section. The C-section allows for increased structural integrity and facilitates wet out in the molding process. The carbon fiber skin 24 includes a first skin portion 40 and a second skin portion 42 that together envelop the core 22. This process of manufacture is via molding, as alluded to above.

The panel assembly 10 is inserted into a compression mold, thus allowing for intricate shapes and attachment features to be molded in a component mounting structure 44, shown in Figure 2. After the panel assembly 10 is inserted in

the tool, a thermoplastic/glass reinforced material fills the mold via a compression or injection molding process. During the molding process, the thermoplastic/glass reinforced material is essentially in a liquid state, which allows for complete material distribution and wet out to the panel assembly 10. These aforementioned processes
5 serve two main functions. First, the carbon fiber skin 24 and balsa wood core 22 are completely encapsulated (box section) with a structural skin 46. Second, module formation of the head lamp, fascia, grille, radiator, and body structure attachments can be performed away from assembly of a motor vehicle.

Calculations can demonstrate the composite panel's attributes as they
10 relate to vehicle stiffness and crash worthiness are far superior to steel structural counterparts. The mass moment of inertia properties for the panel assembly 10 in the Z-direction, e.g., the direction of an impact, reap significant magnitudes of improvement in comparison to the impact directional mass moment of inertia properties of the steel structure.

15 A test was performed with the loading criteria input based on a 4500 pound vehicle subject to 40% offset/40 mile per hour deformable barrier impact. This test yielded a resultant point load (offset from vehicle centerline) of 50,000 pounds. Due to the ultimate tensile strength of steel being exceeded by the stress of the loading condition, the results yielded a catastrophic failure in the steel radiator
20 structure. The comparison of deflection and stresses between the panel assembly 10 and the steel radiator structure demonstrates that the panel assembly 10 would significantly improve vehicle stiffness and crash worthiness.

An additional crash energy attribute of the panel assembly 10 is in the design of the joint connections 32, 34 to the shotgun rails (not shown). The joint
25 connections 32, 34, as shown in Figure 7, would hold the shotgun rails of the motor vehicle and be attached with a through bolt, thus coupling the two upper shotgun rails. Under an offset/high speed crash similar to that discussed above, the coupling of the upper shotguns enables the energy due to impact will be dissipated through each side of the motor vehicle.

30 Lastly, relative to energy management, the panel assembly 10 is advantageous in terms of pedestrian protection (upper leg/lower torso to grille/hood

impact). These advantages may be attributed to the sandwich construction of the panel assembly 10, as it has the ability to distribute local loads and stresses over a large area. This equates to a lower HIC (head impact criteria) value upon pedestrian impact.

5 A mass comparison of the panel assembly 10 and the steel radiator structure for a typical passenger vehicle such as a midsize motor vehicle (a family sedan) yielded the following results: the steel radiator structure (upper rail portion only) weighed 6.6 pounds in comparison to 5.33 pounds for the panel assembly 10. The overall approximate weight of the steel radiator structure and panel assembly 10,
10 without lamp canisters or integrated air deflectors, are 15.5 and 8.14 pounds, respectively. Therefore, improvements of energy dissipation are matched by the reduction in weight to the motor vehicle.

 The invention has been described in an illustrative manner. It is to be understood that the terminology, which has been used, is intended to be in the nature
15 of words of description rather than of limitation. Many modifications and variations of the invention are possible in light of the above teachings. Therefore, within the scope of the appended claims, the invention may be practiced other than as specifically described.

What is claimed is:

1. A panel assembly securable to a front end of a motor vehicle for positioning and securing a plurality of elements thereto, said panel assembly comprising:
 - an upper section defining a length extending between a driver end and a passenger end;
 - a lower section extending between an upper driver end and an upper passenger end, said upper driver and passenger ends fixedly secured to said length of said upper section; and
 - a component mounting structure molded to said skin of said upper and lower sections, said component mounting structure adapted to have the plurality of elements secured thereto in spaced relation such that said panel assembly may be assembled to the motor vehicle with the plurality of elements secured to said panel assembly, characterized by said upper and lower sections each comprising a molded skin encapsulating a core and said component mounting structure comprising a flange extending away from said core.
2. A panel assembly as set forth in claim 1 wherein said skin includes a first skin portion and a second skin portion, said first skin portion covers a portion of said core and said second skin portion cooperates with said first skin portion, encapsulating said core.
3. A panel assembly as set forth in claim 2 wherein said core is fabricated of balsa wood.
4. A panel assembly as set forth in claim 3 wherein said skin includes carbon fiber.
5. A panel assembly as set forth in claims 1 to 4 wherein said first skin portion includes said flange.
6. A panel assembly as set forth in claim 5 wherein said second skin portion includes said flange.
7. A panel assembly as set forth in claim 6 wherein said upper section includes joint connections disposed at said driver end and said passenger end.

1/3

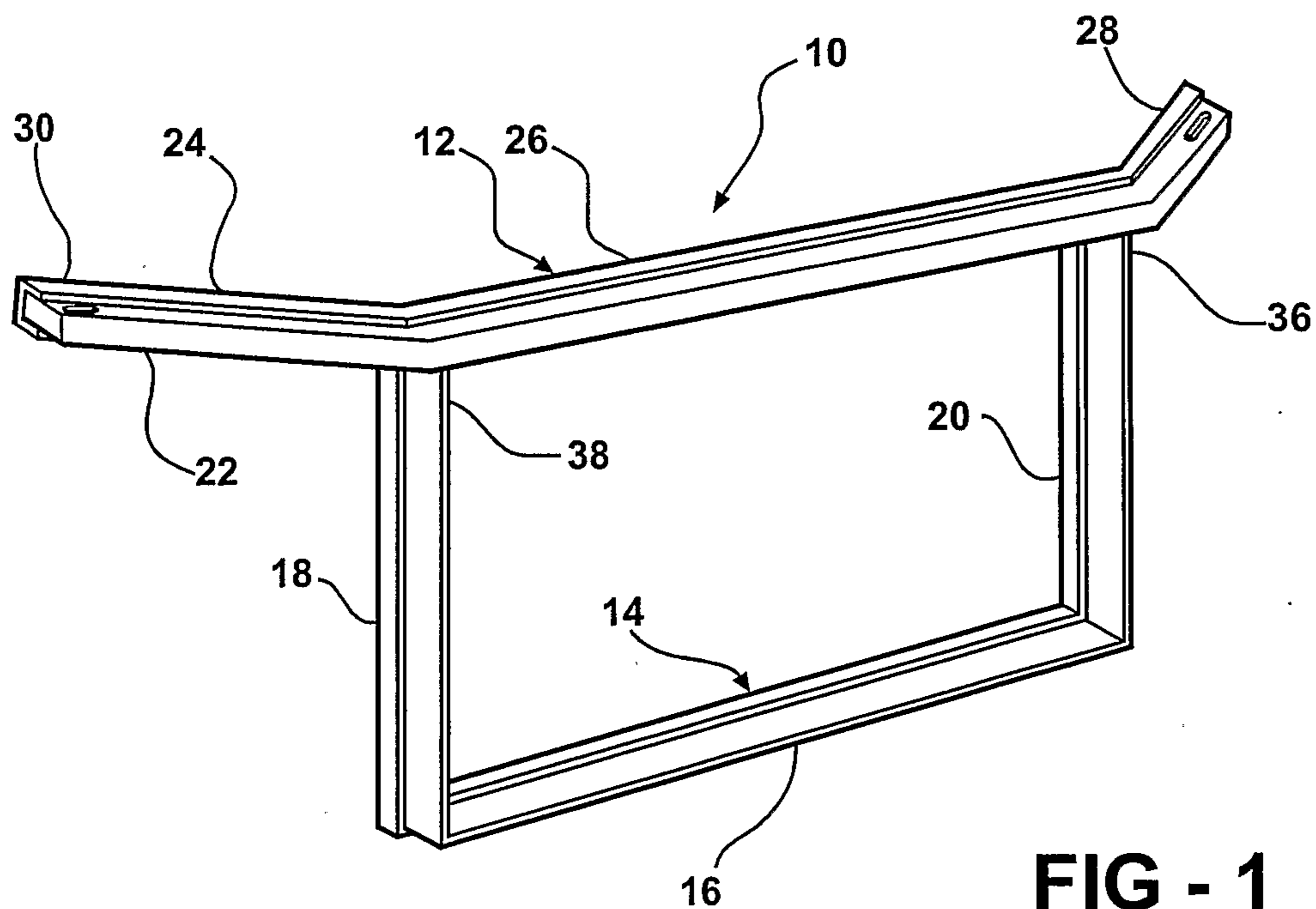

FIG - 1

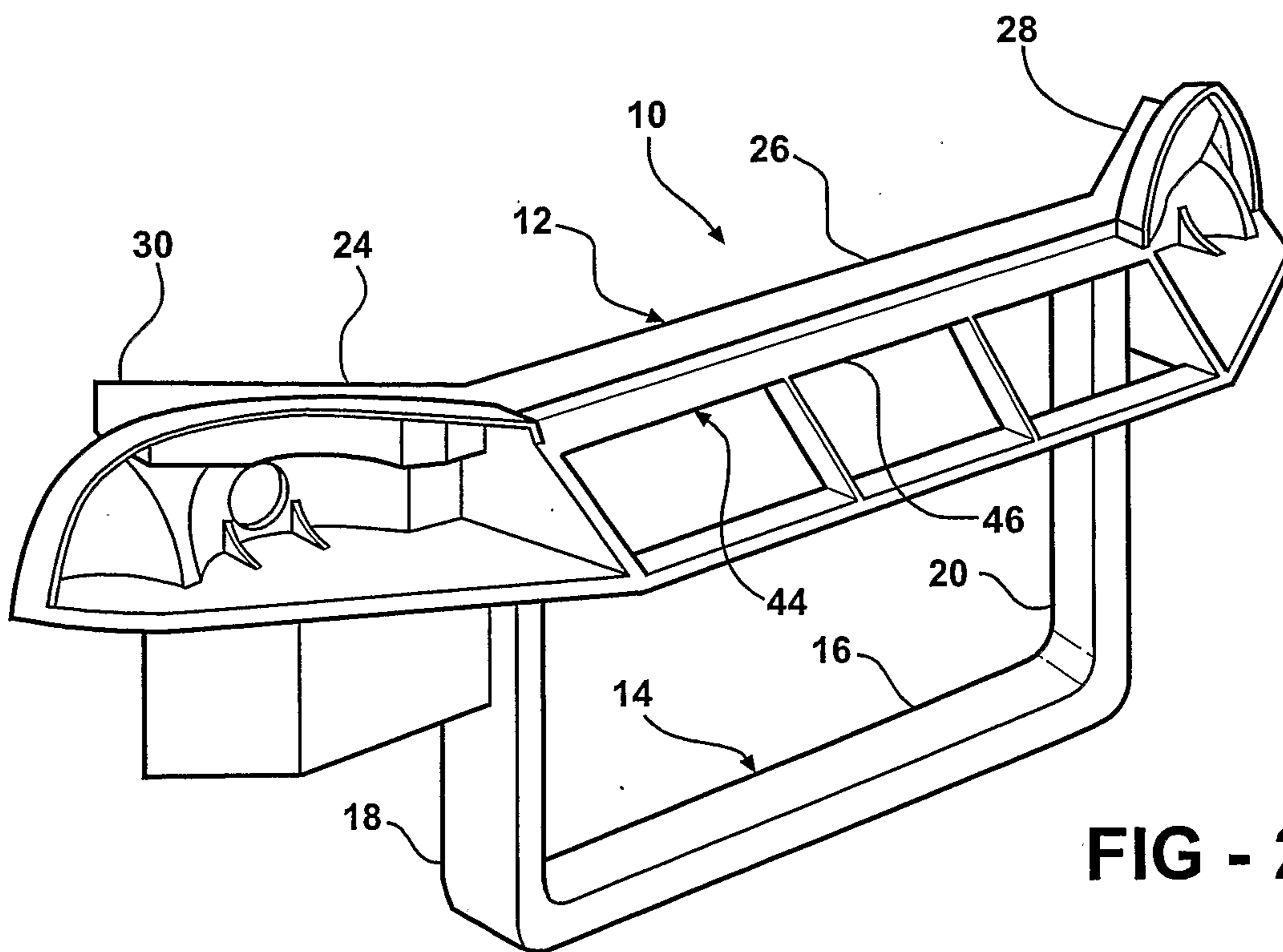

FIG - 2

3/3

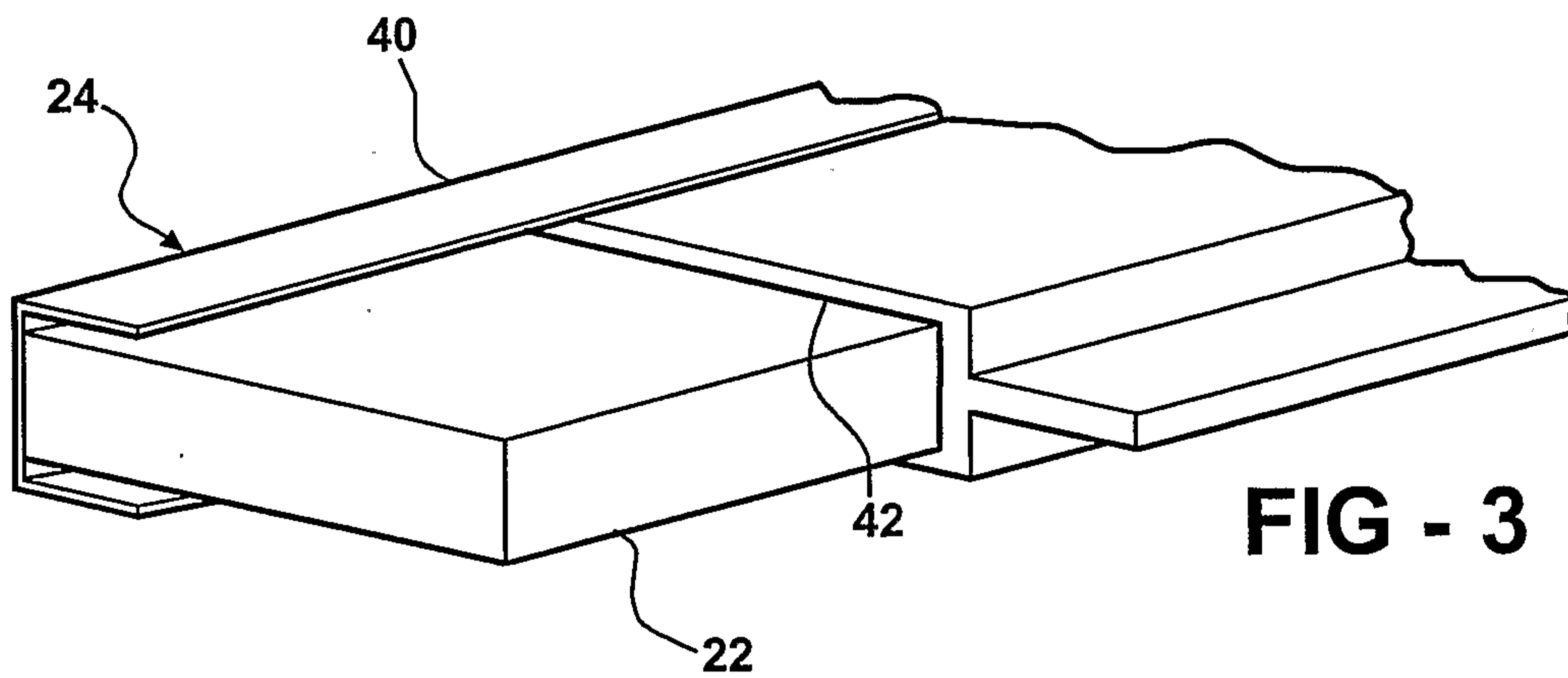

FIG - 3

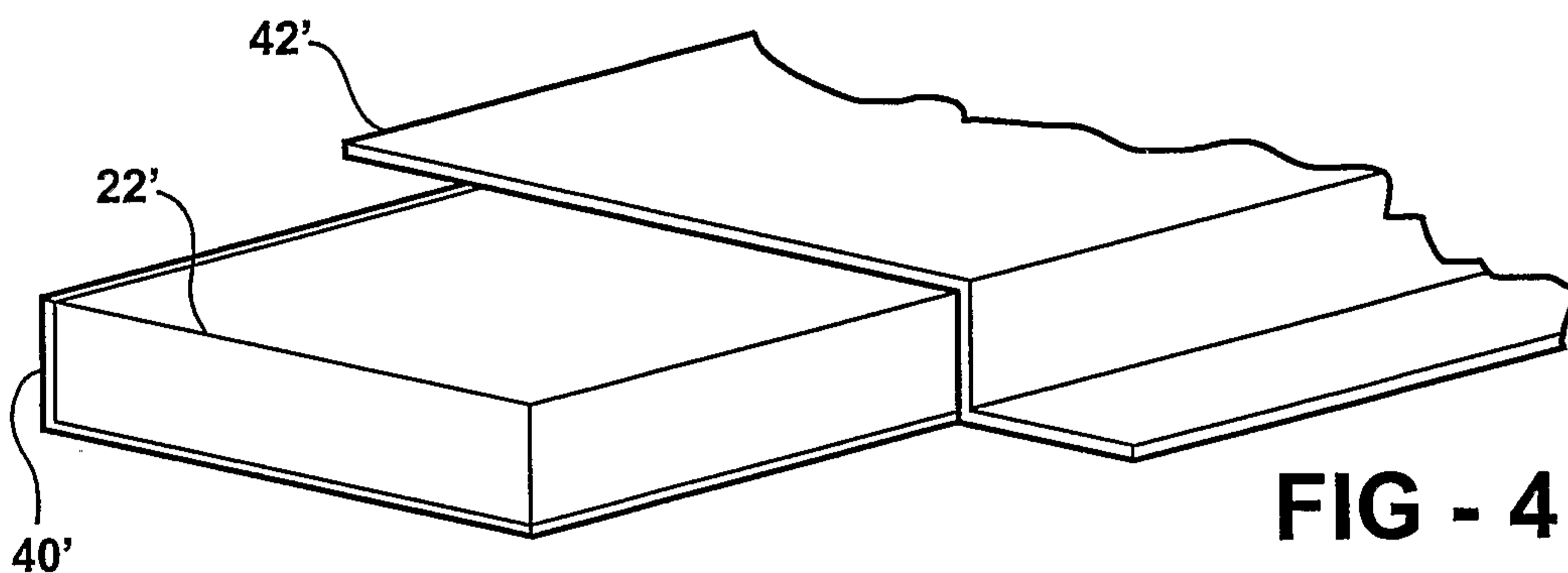

FIG - 4

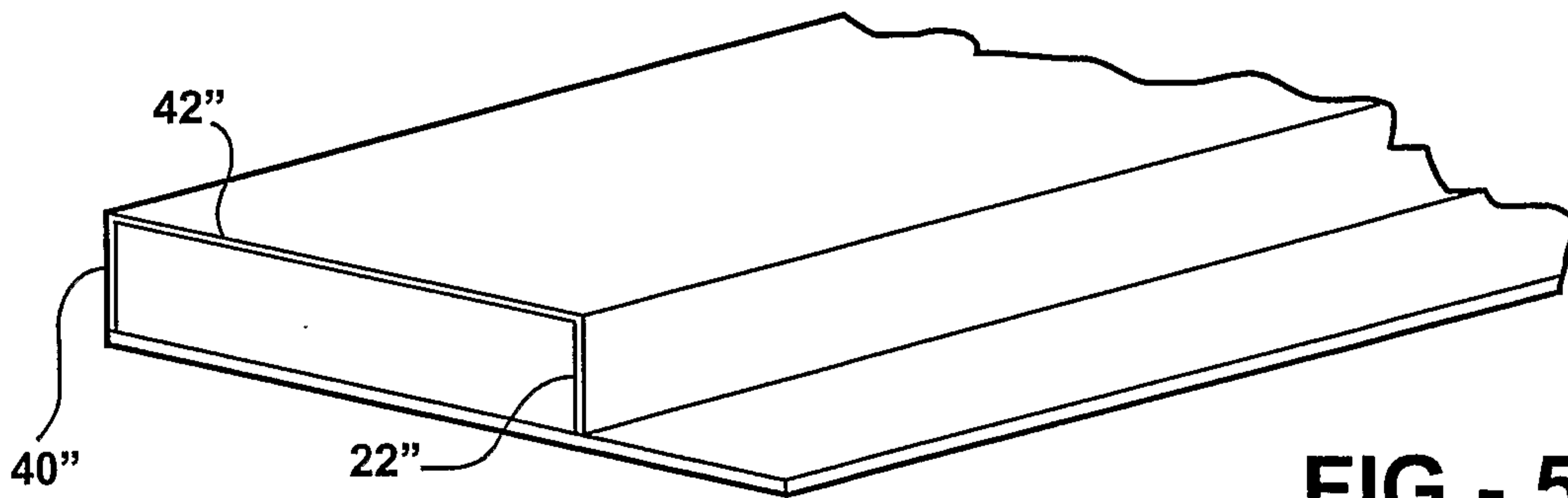

FIG - 5

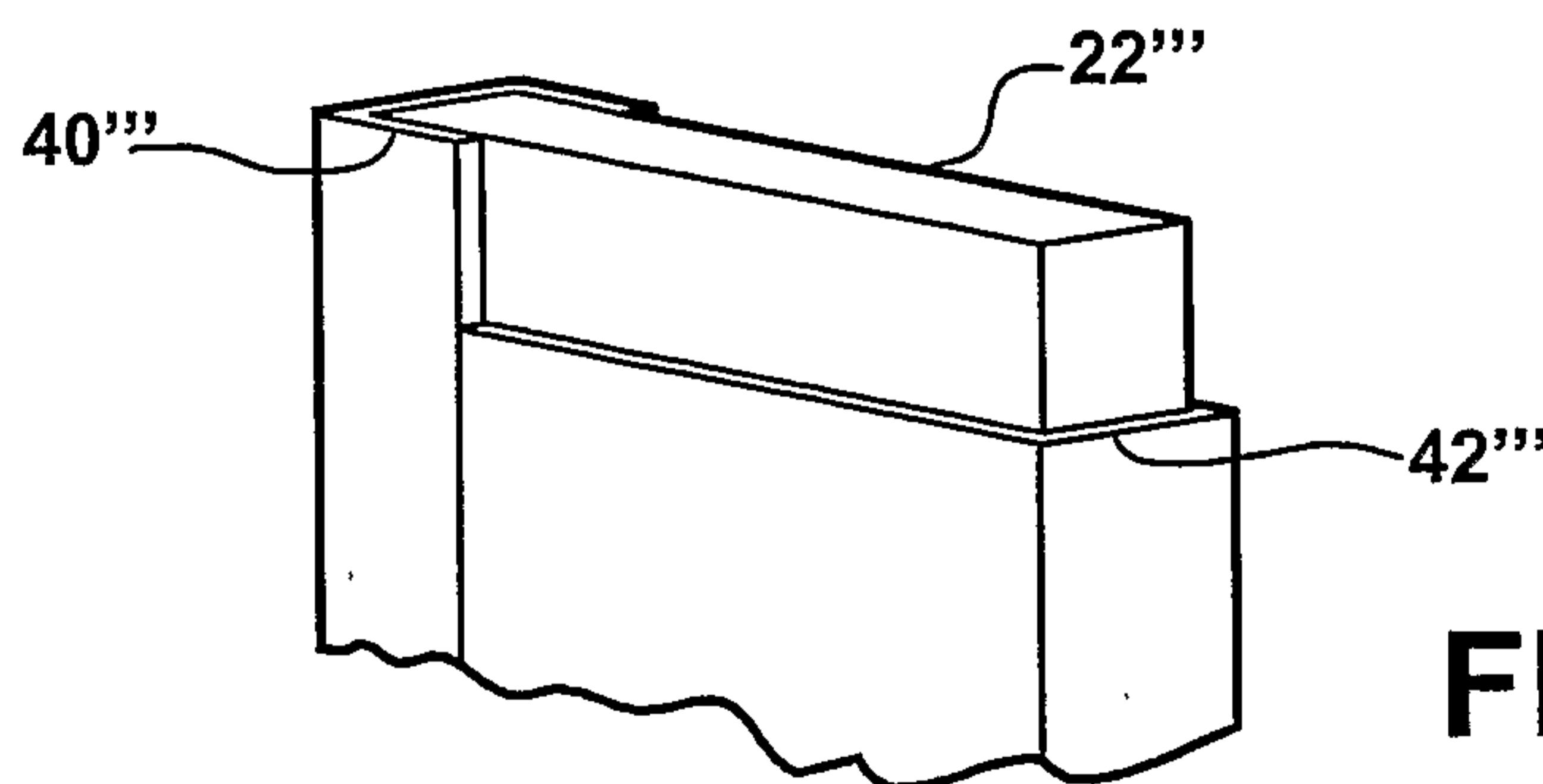

FIG - 6

2/3

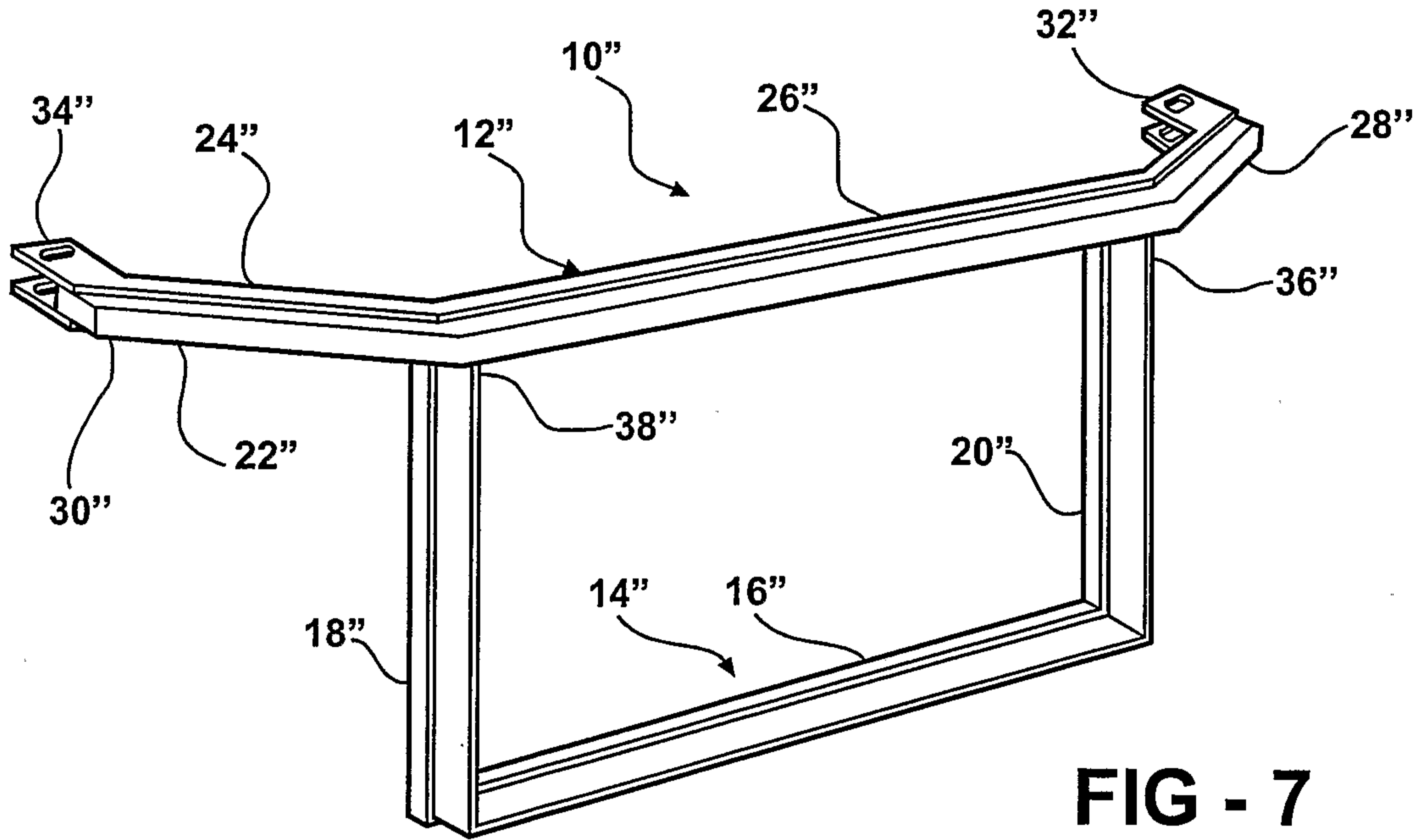

FIG - 7

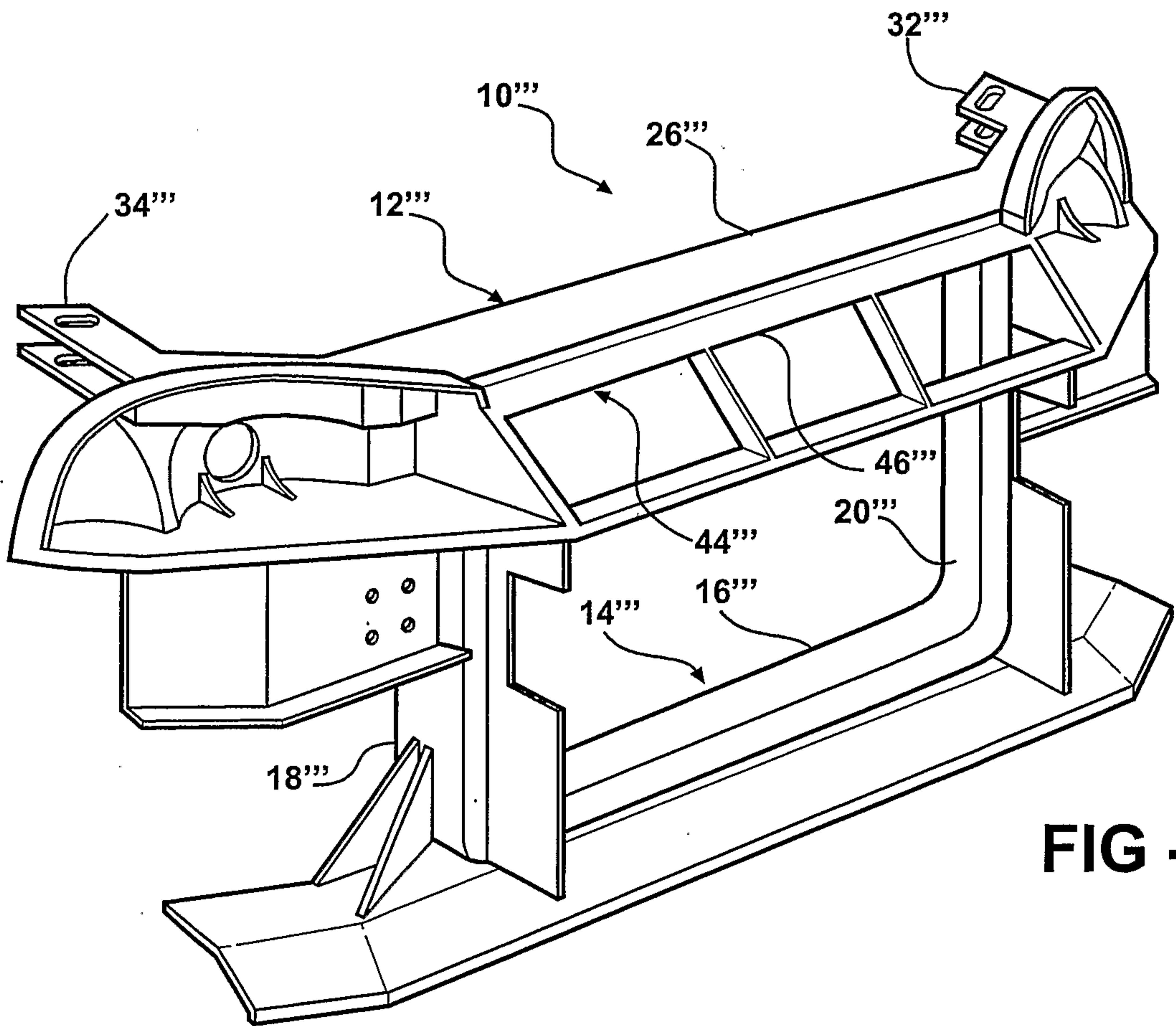

FIG - 8

