



Europäisches Patentamt
European Patent Office
Office européen des brevets



(11) **EP 0 943 760 B1**

(12) **EUROPEAN PATENT SPECIFICATION**

(45) Date of publication and mention
of the grant of the patent:
19.03.2003 Bulletin 2003/12

(51) Int Cl.7: **E05B 17/20, E05B 9/04**

(21) Application number: **99200139.6**

(22) Date of filing: **20.01.1999**

(54) **Cylinder lock**

Zylinderschloss

Serrure cylindrique

(84) Designated Contracting States:
AT BE DE DK ES FR GB IT LU NL SE

• **van der Wal, Jan Willem**
7471 ME Goor (NL)

(30) Priority: **19.03.1998 NL 1008637**

(74) Representative: **Lips, Hendrik Jan George, Ir.**
HAAGSCH OCTROOIBUREAU
Breitnerlaan 146
2596 HG Den Haag (NL)

(43) Date of publication of application:
22.09.1999 Bulletin 1999/38

(73) Proprietor: **Ankerslot bv**
7550 AM Hengelo (NL)

(56) References cited:
DE-A- 3 801 234 **DE-A- 3 904 535**
DE-A- 19 651 432 **FR-A- 2 158 680**
US-A- 1 529 071 **US-A- 2 058 895**
US-A- 3 019 632 **US-A- 5 121 619**

(72) Inventors:
• **Dondorff, Jan**
7523 CA Enschede (NL)

EP 0 943 760 B1

Note: Within nine months from the publication of the mention of the grant of the European patent, any person may give notice to the European Patent Office of opposition to the European patent granted. Notice of opposition shall be filed in a written reasoned statement. It shall not be deemed to have been filed until the opposition fee has been paid. (Art. 99(1) European Patent Convention).

Description

[0001] The invention relates to a cylinder lock as described in the preamble of claim 1.

[0002] Such a cylinder lock is known by DE 3 801 234. This shows a lock the cylinder housing of which is provided with a special shaped slot in which a corresponding shaped abutment plate is received which is fixed in said housing by means of bolts. Said abutment plate is provided with an outwards extending abutment lip engaging the safety metal work.

[0003] This forms a rather cumbersome construction comprising a number of parts and by which substantially only removing of the cylinder housing is opposed.

[0004] The object of the invention is to remove these disadvantages and this is obtained by applying the features as indicated in the characterizing portion of claim 1.

[0005] When now a tap bolt is screwed into the inner cylinder and a force is exerted on it, the cylinder housing will break at the position of the operating member of the bolt of the lock. When the assembly is pulled further outwards the shank of said pin will contact the safety metal work, the pin will be tilted and the edge of the head of the pin will engage and grasp into said inner cylinder as well as in the safety metalwork. Owing to this, the inner cylinder with the cylinder housing can not be pulled out further.

[0006] In particular, the tilting pin will consist of two cylindrical, coaxial parts with the head having a larger diameter than the shank. This enables simple manufacturing of the tilting pin. Then the recess in the wall of said cylinder housing, in which the head of the tilting pin is to be mounted, will also have a simple form. At the same time it is achieved that the shank of the tilting pin, on tilting the pin, will not directly contact the wall of the recess in the cylinder housing.

[0007] Obviously, the tilting pin must be able to tilt in relation to the cylinder housing wall but should be fixedly mounted in it, so that it can not drop out of the recess and into the cylinder housing. In connection with that, the head of the tilting pin can be secured by means of a light drive fit or by glueing or in a like way.

[0008] The invention is further explained by way of an embodiment shown in the drawing, in which:

fig. 1 shows a perspective view of a cylinder housing of a cylinder lock having the accompanying safety metalwork in which the inner cylinder in one part of it has been omitted for reasons of clarity;

fig. 2 shows a perspective view, on an enlarged scale, of a tilting pin used with the lock according to fig. 1; and

fig. 3 shows a perspective view of the lock according to fig. 1 when its cylinder housing has been pulled out over a certain distance and the tilting pin is in its operational position.

[0009] Fig. 1 shows a cylinder housing 1 having in its part at the far right an inner cylinder 2 indicated only by some dash lines. A key can be inserted into the inner cylinder.

5 [0010] Situated between both cylindrical parts of the cylinder housing 1 are means for actuating the bolt of said lock. The bolt and said means for actuating it can be of known construction and therefore have not been illustrated in the drawing.

10 [0011] The cylinder housing 1 is received in a safety metalwork 3, which can be fastened onto a door or window.

[0012] A recess is made in the wall 4 of the cylinder housing 1, in which recess a tilting pin 6 is received, in particular its head 7, see Fig. 2, in such a way that the shank 8 of the tilting pin 6 protrudes beyond the cylinder housing 1. The head 7 can be secured in the wall 4 by light drive fit or by glueing.

[0013] When someone tries to pull the inner cylinder 20 out with force in the direction of the arrow P, the cylinder housing 1 will break at the location of the transition 9 between both cylindrical parts, as shown in Fig. 3. Then, the shank 8 of the tilting pin 6 contacts the safety metalwork 3 and the pin will tilt as shown in Fig. 3. Due to that, a part of the edge 10 of the head 7 of the pin 6 will engage the inner cylinder 2 and will grasp into it. The opposite part of the edge 11 of the head 7 will at the same time grasp into the wall of the cavity in the safety metalwork 3, in which cavity the cylinder housing 1 is received.

[0014] The cylinder housing 1 and the inner cylinder 2 can not be pulled out further, so that the lock is protected against burglary.

[0015] Naturally, the tilting pin 6 need not consist of cylindrical parts but said parts can also have a more rectangular shape.

[0016] Therefore, it will be obvious that only one possible embodiment of a cylinder lock according to the invention has been illustrated in the drawing and described above and that many modifications can be made without leaving the inventive idea, as it is indicated in the claims.

45 Claims

1. Cylinder lock comprising a safety metalwork (3) which can be secured in a door or the like, a cylinder housing (1) being fixed in relation to said metalwork, in said housing an inner cylinder (2) being received in which a key can be inserted so that the inner cylinder (2) can be rotated and the bolt of said lock can be operated, a means being provided to prevent moving said housing (1) out of the door by pulling it outwards such as by means of said inner cylinder (2), **characterized in that** said means is formed by a tilting pin (6) comprising a head (7) and a shank (8), said head (7) being located in a recess in the

wall (4) of said housing (1) and said shank (8) protruding beyond said wall (4) in such a way that when the housing (1) is pulled outwards the shank (8) will engage said safety metalwork (3) and will cause tilting of said pin (6) and the edge of the head (7) of said pin will grasp into said inner cylinder (2) as well as into the safety metalwork (3).

2. Cylinder lock according to claim 1, **characterized in that** the tilting pin (6) consists of two cylindrical, coaxial parts (7,8) from which the head (7) has a larger diameter than the shank (8).
3. Cylinder lock according to claim 1 or 2, **characterized in that** the head (7) of the tilting pin (6) is secured in said cylinder housing (1) by means of a light drive fit or by glueing or in a similar way.

Patentansprüche

1. Zylinderschloß, das ein Sicherungsmetallstück (3) aufweist, das in einer Tür oder einem ähnlichen Gegenstand gesichert werden kann, ein Zylindergehäuse (1) ist relativ zu dem Metallstück fixiert, in dem Gehäuse ist ein innerer Zylinder (2) aufgenommen, in welchen ein Schlüssel eingeführt werden kann, so daß der innere Zylinder (2) gedreht werden kann und daß der Bolzen des Verschlusses bedient werden kann, Mittel sind dafür vorgesehen, eine Bewegung des Gehäuses (1) aus der Tür heraus dadurch zu vermeiden, daß es beispielsweise durch den inneren Zylinder (2) herausziehbar ist, **dadurch gekennzeichnet, daß** diese Mittel durch einen geneigten Stift (6) ausgebildet sind, der einen Kopf (7) und einen Schaft (8) aufweist, wobei der Kopf (7) innerhalb einer Vertiefung in der Wand (4) des Gehäuses (1) angeordnet ist und wobei der Schaft (8) über die Wand (4) derart hervorsteht, daß beim Herausziehen des Gehäuses (1) der Schaft (8) in das Sicherheitsmetallstück (3) eingreift und dabei eine Neigung des Stiftes (6) hervorruft und daß die Flanke des Kopfes (7) des Stiftes in den inneren Zylinder (2) als auch in das Sicherheitsmetallstück (3) eingreift.
2. Zylinderschloß nach Anspruch 1, **dadurch gekennzeichnet, daß** der geneigte Stift (6) aus zwei zylindrischen, coaxialen Stücken (7, 8) besteht, von denen der Kopf (7) einen größeren Durchmesser als der Schaft (8) aufweist.
3. Zylinderschloß nach Anspruch 1 oder 2, **dadurch gekennzeichnet, daß** der Kopf (7) des geneigten Stiftes (6) innerhalb des zylindergehäuses (1) durch Mittel einer Leichtgangpassung oder durch Verkleben oder in ähnlicher Art und Weise gesichert ist.

Revendications

1. Serrure cylindrique comprenant une plaque métallique de sécurité (3) qui peut être montée sur une porte ou analogue, un logement cylindrique (1) étant fixé en relation avec ladite plaque métallique, un cylindre intérieur (2) étant incorporé dans ledit logement dans lequel une clef peut être introduite de telle sorte que le cylindre intérieur (2) peut être mis en rotation et que le verrou de ladite serrure peut être actionné, des moyens étant prévus pour empêcher le mouvement dudit logement (1) hors de la porte en le tirant vers l'extérieur tel qu'au moyen dudit cylindre intérieur (2), **caractérisé en ce que** lesdits moyens sont formés par une goupille basculante (6) comprenant une tête (7) et un fût (8), ladite tête (7) étant située dans un évidement dans la paroi (4) dudit logement (1) et ledit fût (8) faisant saillie au-delà de ladite paroi (4) de telle sorte que lorsque le logement (1) est tiré vers l'extérieur, le fût (8) coopère avec ladite plaque métallique de sûreté (3) et provoque le basculement de ladite goupille (6) et le bord de la tête (7) de ladite goupille et le bord de la tête (7) de ladite goupille s'engage dans ledit cylindre intérieur (2) ainsi que dans la plaque métallique de sûreté (3).
2. Serrure cylindrique selon la revendication 1, **caractérisée en ce que** la goupille basculante (6) consiste en deux parties coaxiales cylindriques (7,8) dont la tête (7) présente un plus grand diamètre que le fût (8).
3. Serrure cylindrique selon la revendication 1 ou 2, **caractérisée en ce que** la tête (7) de la goupille basculante (6) est montée dans ledit logement cylindrique (1) au moyen d'un léger ajustement serré ou par collage ou d'une manière similaire.

FIG. 2

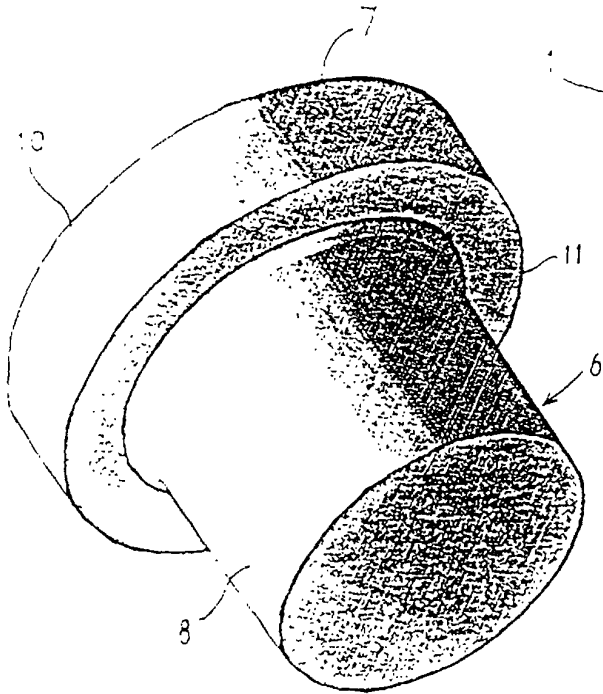

FIG. 1

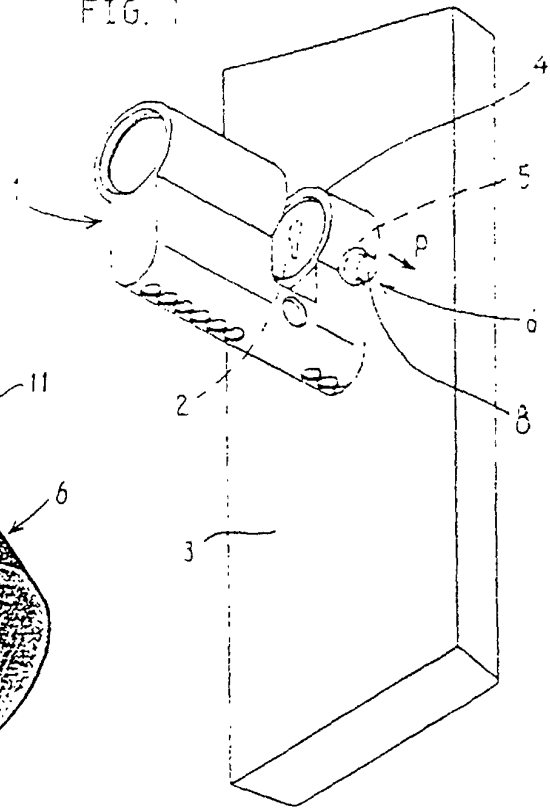

FIG. 3

