



(12) **EUROPEAN PATENT APPLICATION**

(43) Date of publication:
27.03.2019 Bulletin 2019/13

(51) Int Cl.:
G01T 1/12 (2006.01) A61N 5/00 (2006.01)

(21) Application number: **18168858.1**

(22) Date of filing: **29.05.2013**

(84) Designated Contracting States:
AL AT BE BG CH CY CZ DE DK EE ES FI FR GB GR HR HU IE IS IT LI LT LU LV MC MK MT NL NO PL PT RO RS SE SI SK SM TR

- **SARFEHNIA, Arman**
Toronto, Ontario M4S 2G8 (CA)
- **RENAUD, James**
Verdun, Quebec H4G 1Y6 (CA)

(30) Priority: **29.05.2012 US 201261652540 P**

(74) Representative: **Alton, Andrew**
Urquhart-Dykes & Lord LLP
Arena Point
Merrion Way
Leeds LS2 8PA (GB)

(62) Document number(s) of the earlier application(s) in accordance with Art. 76 EPC:
13796823.6 / 2 856 210

(71) Applicant: **Sun Nuclear Corporation**
Melbourne, FL 32940 (US)

Remarks:

- This application was filed on 23-04-2018 as a divisional application to the application mentioned under INID code 62.
- Claims filed after the date of filing of the application (Rule 68(4) EPC).

(72) Inventors:
 • **SEUNTJENS, Jan**
Montreal, Québec H3E1W (CA)

(54) **METHOD AND SYSTEM FOR CALORIMETRY PROBE**

(57) Radiotherapy is one of the most effective treatments for cancer and its success depends critically on accurate targeting and delivery of the correct radiation dose. Accurate dosimetry is therefore essential to maintain and improve patient survival rates. However, size and long wait times currently limit water and graphite based calorimeters to standards laboratories leaving field-based dosimetry to ionization chamber measurements which depend upon a reference field-specified calibration factor. It would therefore be beneficial to provide

radiotherapy equipment operators a direct approach of clinical reference dosimetry wherein the dosimeter provides increased independence on dose, dose rate, radiation energy, and energy type, etc. It would be further beneficial for such novel clinical dosimeters to be compact, function as secondary standards used routinely for measurements and allow radiotherapy doses to be measured directly and in an absolute manner. According to embodiments of the invention novel compact graphite probe calorimeters are provided.

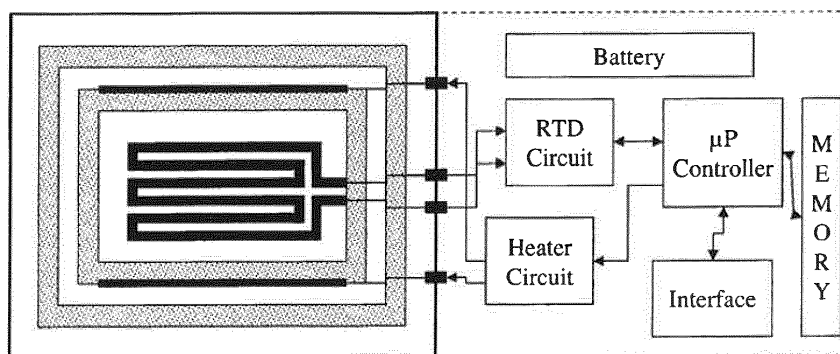

Figure 8

Description**CROSS-REFERENCE TO RELATED APPLICATIONS**

5 [0001] This patent application claims the benefit of U.S. Provisional Patent Application US 61/652,540 filed May 29, 2012 entitled "Method and System for Calorimetry and Clinical Dosimetry", the entire contents of which are included by reference.

FIELD OF THE INVENTION

10 [0002] The present invention relates to calorimeters and in particular compact graphite based radiation calorimeters.

BACKGROUND OF THE INVENTION

15 [0003] Radiotherapy is one of the two most effective treatments for cancer. The success of radiotherapy in curing cancer depends critically on accurate targeting and delivery of the correct radiation dose. If the dose delivered to a patient is too low then cancerous cells may survive leading to a recurrence of the cancer. If the dose delivered is too high then surrounding healthy tissue is more likely to be damaged. For example, optimal treatment of some head and neck tumours requires that the dose delivered should be within only a few percent of that prescribed. Uncertainty in
20 patient positioning means that it is crucial for all other errors to be as small as is possible. Accurate dosimetry is therefore essential to maintain and improve patient survival rates.

[0004] Radiation dosimetry is the measurement and calculation of the absorbed dose in matter and tissue resulting from the exposure to indirect and direct ionizing radiation. It is a scientific subspecialty in the fields of health physics and medical physics that is focused on the calculation of internal (internal dosimetry) and external doses from ionizing
25 radiation. In medical physics absorbed dose is reported in SI units of gray (Gy) where 1 Gy = 1 J/kg, and in radiation protection dosimeters in units of Sieverts (Sv).

[0005] There are different ways of measuring absorbed dose from ionizing radiation. For workers who come in contact with radioactive substances or may be exposed to radiation routinely, personal dosimeters are typically employed and intended primarily for warning / notification rather than accurate determination of dose. In the United States, these
30 dosimeters are usually thermoluminescent dosimeters (TLD) or optically stimulated luminescence (OSL) dosimeters, whilst personal dose monitors based on photographic emulsions that are sensitive to ionizing radiation are also available. In radiotherapy, such as with linear particle accelerators in external beam radiotherapy, routine accurate calibration is typically and most commonly obtained using ionization chambers. However other detectors ranging from semiconductor-based dosimeters to radiochromic films may also be used for certain applications.

[0006] Because the human body is approximately 70% water and has an overall density close to 1 g/cm³, for consistency, absorbed dose measurements are normally made in and/or reported as dose to water. National standards laboratories such as US National Institute of Standards and Technology (NIST) and UK National Physical Laboratory (NPL) provide calibration factors for ionization chambers and other measurement devices that are used to convert the instrument's readout, which may be for example ionization, optical density change, current, etc., to absorbed dose to water.
40 The standards laboratories maintain a primary standard, which is normally based on either of three techniques: calorimetry, Fricke dosimetry, or free air ionization chambers. Out of the three, calorimetry, being the measurement of temperature rises due to radiation energy being absorbed in medium, is the most direct and absolute means of determining absorbed dose and is used most commonly.

[0007] A hospital or other users subsequently send their detectors (often ionization chambers) to the laboratory, where
45 it is exposed to a known amount of radiation (as determined using the primary standard) and in turn a calibration factor is issued to convert the instrument's reading to absorbed dose. The user may then use this calibrated detector (secondary standard) to derive calibration factors for other instruments they use (tertiary standards) or field instruments. The uncertainty on the calibration factor of a detector increases inherently with the number of steps in the chain of calibrations relating the device to the primary standard.

[0008] Today many primary standards laboratories use water- or graphite-calorimeters to maintain an absolute photon dosimetry standard. In calorimetry, the basic assumption is that all (or a known fraction) of the absorbed radiation energy appears as heat, so that the measurement of absorbed dose reduces to a measurement of a temperature change. If the absorbed dose to water is to be established, ideally the calorimetric measurements should be made using water, see for example Ross et al in "Water Calorimetry for Radiation Dosimetry" (Phys. Med. Biol., Vol. 41, pp1-29). However,
55 due to many challenges with water calorimetry, including low signal to noise ratio and potential heat defect due to presence of impurities in water, in addition to the cumbersome nature of the device and difficulty of working with a water tank and related accessories, significant research has also been undertaken in the area of graphite calorimetry. Graphite has beneficial radiation absorption characteristics that are similar to those of water, and allows for thermally isolated

segments to be machined and configured so as to permit the measurement of absorbed dose to graphite. At present due to advances in water calorimeters arising from the work of Domen, see for example "Absorbed Dose Water Calorimeter" (Med. Phys., Vol. 7, pp157-159), both graphite and water calorimeters are exploited.

5 [0009] However, due to their general bulkiness and long wait times with establishing thermal equilibrium water and graphite based calorimeters have been to date, within the prior art, limited to standards laboratories. Accordingly, it would be beneficial to provide clinical medical physicists with an alternative approach to ionization chambers for the calibration and quality assurance of radiation therapy equipment including standard as well as small radiation fields. It would be further beneficial for such novel clinical dosimeters to be capable of operating as self-calibrating secondary standards, which may be used routinely for measurements rather than calibration activities only.

10 [0010] Radiotherapy is a field subject to continuing evolution as treatment protocols, radiopharmaceuticals, and radiotherapy equipment address both the rising rates of cancer, as more people live to an old age and as mass lifestyle changes occur in the developing world such that in 2007 approximately 13% of all human deaths worldwide (7.9 million) were cancer related, and currently there are over 200 different known types of cancers. Amongst such developments is the emergence of treatment units specifically designed for stereotactic radiosurgery, wherein small targets inside the body are treated using small static or rotating radiation fields that are at times highly modulated in both intensity and/or shape. Many radiotherapy units such as GammaKnife®, CyberKnife®, TomoTherapy®, and even most conventional linear accelerator (L1NAC) manufacturers Varian®, Siemens®, Elekta® now provide the capabilities of delivering extremely complex treatment deliveries based on stereotactic radiotherapy (SRT) or intensity modulated radiation therapy (IMRT) to treat a given disease site with extreme accuracy and conformality. Accordingly, with these sophisticated techniques comes the requirement for new dosimetry protocols that address absorbed dose calibration in nonstandard radiation fields wherein practices are currently lacking international standards, see for example Alfonso et al in "A New Formalism for Reference Dosimetry of Small and Non-Standard Fields" (Med. Phys., Vol. 35, pp5179-5186). Accordingly, calorimetry could offer a more direct and accurate way of measuring absorbed dose to water in small and composite radiation fields by doing away with the need to transfer calibration factors according to the radiation beam quality of interest.

15 [0011] However, calorimetry is not without its challenges when considering compact field-deployable calorimeters. Graphite has a specific heat capacity one-sixth that of water and therefore for a given radiation dose, its temperature rises 6 times more than an equivalent water based calorimeter give rise to a higher signal to noise ratio.. A typical dose of radiation to a human during radiotherapy treatment is approximately 1- 2Gy, which is 1-2 joules per kilogram. Accordingly, if we consider a calorimeter comprising a 1cm³ piece of graphite, which weighs approximately 2 grams, this would therefore absorb around 2 - 4mJ, which with a specific heat capacity of around 700Jkg⁻¹K⁻¹ equates to a temperature rise of just 1 - 2mK. Accordingly, significant problems exist in insulating the graphite from the ambient clinical environment in order to measure such tiny temperature changes.

20 [0012] Accordingly, embodiments of the invention provide for compact graphite probe calorimeters (GPC) for absolute accurate clinical dosimetry to address the requirements of evolving radiotherapy systems and radiopharmaceutical therapies whilst providing medical radiation oncology technologists and medical physicists with compact, fast, low cost alternatives to ionization chambers for conventional radiotherapy calibration.

25 [0013] Other aspects and features of the present invention will become apparent to those ordinarily skilled in the art upon review of the following description of specific embodiments of the invention in conjunction with the accompanying figures.

40 SUMMARY OF THE INVENTION

[0014] It is an object of the present invention address limitations within the prior art relating to calorimeters and provide compact graphite based radiation calorimeters.

45 [0015] In accordance with an embodiment of the invention there is provided a calorimeter comprising:

- a core providing a predetermined absorption cross-section to a predetermined radiation type;
- a jacket surrounding the core to provide thermal isolation of the core from the ambient environment; a first thermal barrier material disposed between the core and jacket; and
- 50 a temperature dependent resistor thermally coupled to the core.

[0016] The first thermal barrier material may be an aerogel.

[0017] The calorimeter may further comprise: a shield surrounding the jacket to provide further thermal isolation of the core and jacket from the ambient environment; and a second thermal barrier material disposed between the jacket and the shield.

55 [0018] The calorimeter may further comprise: the second thermal barrier material is an aerogel.

[0019] The calorimeter may further comprise: a support providing mechanical support for the core and electrical traces electrically connected to the temperature dependent resistor; wherein the support feeds through and is hermetically

sealed to the shield such that a vacuum is provided within the shield for thermally isolating the core is maintained.

[0020] The calorimeter may further comprise: a heater element at least one of formed on the inner surface of and embedded with the shield.

[0021] A temperature dependent resistor may be at least one of formed on the outer surface of and embedded within the core.

[0022] The temperature dependent resistor may be at least one of a thin film device, a thick film device, and a semiconductor device.

[0023] In accordance with an embodiment of the invention there is provided a method of measuring a radiation dose comprising: providing a calorimeter comprising: a core providing a predetermined absorption cross-section to a predetermined radiation type; a jacket surrounding the core to provide thermal isolation of the core from the ambient environment; a first thermal barrier material disposed between the core and jacket; and a first temperature dependent resistor thermally coupled to the core; measuring the temperature dependent resistor during application of a dose of radiation according to a predetermined regimen; determining the radiation dose in dependence upon at least the measurements of the temperature dependent resistor and a conversion factor relating to the calorimeter.

[0024] The method of measuring a radiation dose may further comprise; providing a heater element within the calorimeter; and controlling the temperature of the core in dependence upon at least one of the first temperature dependent resistor and a second temperature dependent resistor thermally coupled to the core.

[0025] The first and second temperature dependent resistors may comprise at least one of thin film resistive elements formed upon the outer surface of the core and resistive elements embedded within the core.

[0026] The core of the calorimeter may be graphite; and the first thermal barrier material may be an aerogel.

[0027] The calorimeter may further comprise: a shield surrounding the jacket to provide further thermal isolation of the core and jacket from the ambient environment; and a second thermal barrier material disposed between the jacket and the shield.

[0028] In accordance with an embodiment of the invention there is provided a method of verifying a radiotherapy regimen comprising: establishing a predetermined radiotherapy regimen; determining with a microprocessor an expected temperature profile for a calorimeter of predetermined design exposed to the radiotherapy regimen; measuring the temperature profile of a physical calorimeter of the predetermined design when exposed to a radiation source operating according to the predetermined radiotherapy regimen; determining with the microprocessor a decision in dependence upon at least the expected temperature profile and measured temperature profile.

[0029] The physical calorimeter of the predetermined design may comprise: a core providing a predetermined absorption cross-section to a predetermined radiation type; a jacket surrounding the core to provide thermal isolation of the core from the ambient environment; a first thermal barrier material disposed between the core and jacket; and a first temperature dependent resistor thermally coupled to the core.

[0030] The physical calorimeter of the predetermined design may further comprise: a shield surrounding the jacket to provide further thermal isolation of the core and jacket from the ambient environment; and a second thermal barrier material disposed between the jacket and the shield.

[0031] The determination may be made in dependence upon at least one of the time dependent evolution and overall evolution of the measured temperature profile.

[0032] The calorimeter of predetermined design may provide real time measurement of dosage.

[0033] The core of the calorimeter may be graphite; and the first thermal barrier may be an aerogel.

[0034] Other aspects and features of the present invention will become apparent to those ordinarily skilled in the art upon review of the following description of specific embodiments of the invention in conjunction with the accompanying figures.

BRIEF DESCRIPTION OF THE DRAWINGS

[0035] Embodiments of the present invention will now be described, by way of example only, with reference to the attached Figures, wherein:

Figures 1A and 1B depict finite element analysis of a graphite probe calorimeter (GPC) design according to an embodiment of the invention;

Figure 1C depicts FEM heat transfer simulation results for a GPC according to an embodiment of the invention as depicted in Figures 1A and 1B;

Figure 2A depicts a GPC according to an embodiment of the invention consisting of cylindrically nested components of graphite;

Figure 2B depicts the GPC according to an embodiment of the invention in Figure 2A with the platinum alloy thermistor leads covered by polyimide tubing and are threaded through holes in the jacket and shield caps;

Figure 2C depicts the GPC according to an embodiment of the invention in Figures 2A and 2B integrated into a

PMMA stem protecting the electrical connections from the physical strain of handling and waterproofing the GPC for submerged dose measurements;

Figure 3A depicts a schematic diagram of the GPC design of Figures 2A through 2B according to an embodiment of the invention;

Figure 3B depicts a microCT scan of the GPC according to the design of Figures 2A, 2B, and 3A according to an embodiment of the invention showing the thermistors fixed to the core;

Figure 4A depicts experimental calorimetric data in raw data from in units of active bridge voltage for the GPC according to an embodiment of the invention in Figures 2A through 3B acquired during a 30s / 200MU irradiation;

Figure 4B depicts an ohm calibration, in which the bridge voltage response to a change in resistance of a balanced decade box by 1Ω is recorded;

Figure 4C depicts a raw experimental calorimetric signal for a GPC according to an embodiment of the invention in Figures 2A through 3B acquired during a 30s / 200MU irradiation with the GPC within a $30 \times 30 \times 30 \text{cm}^3$ water phantom;

Figure 5A depicts a GPC according to an embodiment of the invention with thin film heater and resistance elements formed upon the graphite elements;

Figure 5B depicts a GPC according to an embodiment of the invention with thin film heaters formed upon the graphite jacket and resistance element within the graphite core;

Figure 5C depicts a GPC according to an embodiment of the invention with resistive element embedded within the graphite core and heating elements embedded within the jacket;

Figure 6 depicts a GPC according to an embodiment of the invention with thin film heaters upon the graphite jacket and multiple resistance elements formed upon the graphite core;

Figure 7A depicts a GPC according to an embodiment of the invention wherein a graphite core with thin file resistance elements is sealed within a jacket under vacuum with low temperature glass based sealing;

Figure 7B depicts a GPC according to an embodiment of the invention with wire wound heaters formed around the graphite core and resistance element within the graphite core;

Figure 8 depicts an integrated GPC assembly comprising a GPC according to an embodiment of the invention in conjunction with thermal control and temperature sensing electronics for a stand-alone battery operated absolute calorimeter;

Figure 9 depicts an integrated GPC assembly comprising a GPC according to an embodiment of the invention in conjunction with thermal control, calorimeter and jacket temperature sensing electronics for a stand-alone battery operated absolute calorimeter with wireless interface; and

Figure 10 depicts a GPC according to an embodiment of the invention with multiple graphite cores with wire wound heaters formed around each core, with core specific temperature sensors and jacket heating elements segmented to align with each graphite core.

DETAILED DESCRIPTION

[0036] The present invention is directed to calorimeters and in particular compact graphite based radiation calorimeters.

[0037] The ensuing description provides exemplary embodiment(s) only, and is not intended to limit the scope, applicability or configuration of the disclosure. Rather, the ensuing description of the exemplary embodiment(s) will provide those skilled in the art with an enabling description for implementing an exemplary embodiment. It is being understood that various changes may be made in the function and arrangement of elements without departing from the spirit and scope as set forth in the appended claims.

1. DESIGN

[0038] A calorimeter provides a unique primary absorbed dose standard in that it does not require a radiation field for calibration. This dosimetric technique is based on the assumption that the dose, D , absorbed in a medium contributes to a temperature rise, ΔT , which is proportional to the specific heat capacity, c_p , where $D=c_p \cdot \Delta T$. However, in practice, heat transfer, heat defects, radiation type, and radiation field perturbations due to the presence of the calorimeter are issues to consider, and potentially require consideration of corrections. Within the following description of a design and implementation for a compact, solid state calorimeter according to an embodiment of the invention a design goal of operating simultaneously for high-energy photon and electron beams was set. The photon beam being defined as x-rays from a ^{60}Co source up to 18MV energy and electron beams with energies $4\text{MeV} \leq E_e \leq 25\text{MeV}$.

[0039] Within the embodiments of the invention described below a core design emphasis was placed on portability and ease-of-use. Accordingly, the format of the calorimeter was chosen to be probe-like, similar in size to an air-filled 0.6cm^3 ionization chamber, giving it a comparable spatial resolution. The design was also intended to be robust enough to allow for repeated handling. However, these goals were subsidiary to the overarching goal of the GPC is to develop

an absolute clinical dosimeter capable of providing a direct measurement of absorbed dose to water to within a sub-percent uncertainty in a practical time frame.

[0040] However, it would be evident to one skilled in the art that calorimeters according to embodiments of the invention may be designed with different design goals in terms of the radiation types, radiation energies, dosage to be measured etc. Further, other mechanical design goals may form the basis of the design in terms of volume, geometric constraints, geometry, support, and handling for example. It would also be evident that calorimeters according to embodiments of the invention may be designed for a single radiation source or multiple sources. Accordingly dosimeters according to embodiments of the invention provide increased independence on dose, dose rate, radiation energy, and energy type with appropriate design. Additionally, the embodiments of the invention describe a single graphite core but it would also be evident that embodiments of the invention may be implemented with multiple graphite cores to provide dosimetry data in respect of a predetermined physical geometry defined by an assembly housing for the multiple graphite cores or assembly into which multiple dosimeters are disposed.

1A. Mechanical Design Considerations: The numerical design optimization study was conducted with the intent to fabricate a graphite calorimeter able to operate in the dual beams and energy ranges identified above at dose rates comparable to the range of normal LINAC operation and greater. However, embodiments of the invention operating with / without active stabilization and similar or different geometries may be employed to perform measurements at lower dose rates. Additionally, with improved response times calorimeters according to embodiments of the invention allow concurrent dose application and measurements in either continuous or pulsed approaches. With an emphasis placed on portability and easy-of-use, the format of the calorimeter was chosen to be probe-like with a target size equivalent to an air-filled 0.6cm³ ionization chamber giving it good spatial resolution. Additionally, the design should be robust enough to allow for routine handling, for example placement within and subsequent removal from water or water-equivalent phantoms, and be able to provide a direct and reliable measurement of absorbed dose to water, with an uncertainty of 1% or better, with real time dose data and fast settling.

1B. Heat Transfer Modeling: In quasi-adiabatic radiation mode, a graphite calorimeter measures the integrated dose-rate averaged over a graphite core volume based on its fundamental relation to temperature rise and the heat transfer, see Seuntjens et al in "Photon Absorbed Dose Standards" (Metrologia, Vol. 46, ppS39-S58), as described in Equations (1A) and (1B) where ΔT_{gr} is the temperature rise averaged over the core due to radiation, and $c_{gr,p}$ is the specific heat capacity of graphite at constant pressure.

$$\overline{D}_{gr} = c_{gr,p} \cdot \Delta T_{gr} \cdot k_{ht} \cdot \prod k_i \quad (1A)$$

$$\overline{D}_{gr} = \frac{E_{rad}}{m_{gr}} = \frac{\Delta E_{total} - \Delta E_{transfer}}{m_{gr}} = c_{gr,p} * \Delta T_{gr} - \frac{\Delta E_{transfer}}{m_{gr}} \quad (1B)$$

[0041] Within Equation (1A) the heat loss, k_{ht} is the most significant effect perturbing the measurements and hence obtaining accurate dose measurements such that the GPC optimization was primarily driven by finite element method-based numerical heat-transfer studies conducted using COMSOL Multiphysics® software. The product $\prod k_i$ corrects for lesser effects which may be included or excluded such as in the proof of principle simulations and design analysis described below in respect of embodiments of the invention. Such effects include, but are not limited to, the presence of impurities in the graphite (which has been assumed to be small for a GPC of the target 0.6cm³ volume described below but may not be negligible for other GPC designs), and the volume averaging effect of the graphite core. Accordingly, Equation (1B) represents a simplification such that the single correction term, $\Delta E_{transfer}/m_{gr}$, accounts for the effects of heat transfer from the core and is defined as the difference between the ideal temperature rise, in the absence of heat transfer processes, and the actual temperature rise. In calorimetry, a temperature rise is traditionally determined by linearly fitting the pre- and post-irradiation temperature traces, extrapolating them to the midpoint of the irradiation period and measuring the difference in temperature, see Seuntjens et al in "Review of Calorimeter-based Absorbed Dose to Water Standards" (IAEA Int. Symp. on Standards and Codes of Practice in Med. Rad. Dosimetry, IAEA-CN-96-3).

[0042] Referring to Figure 1A there is depicted a finite element analysis meshing of a GPC according to an embodiment of the invention wherein the input parameters to the thermal simulation included thermal properties of the involved materials, boundary conditions, and the distribution of heat sources and heat sinks spatially and temporally. The resulting radiation-induced temperature distribution in a GPC according to an embodiment of the invention is depicted in Figure 1B. Throughout the optimization process, a 2D axially-symmetric modeling of the GPC was conducted, dramatically

reducing the number of mesh elements (degrees of freedom) required to describe the detector geometry. Thermistors were modeled as spheres and their power dissipation was taken into account as constant heat sources. Heat loss from the core due to conduction via the thermistor leads was also included in the model. The relative calculation tolerance was kept below 0.1% for all simulations.

[0043] For each design variation evaluated, the average temperature of the core was recorded as a function of time for the purpose of calculating a temperature rise through extrapolation of the pre- and post-irradiation traces. Such an average temperature plot for a GPC according to an embodiment of the invention being depicted in Figure 1C from a numerical finite element method (FEM) based heat transfer study conducted using COMSOL Multiphysics™ software. Accordingly, the fast response of the GPC according to an embodiment during dosing, the linear portion of the results wherein a temperature rise of approximately 700mK is observed within approximately 40 seconds of exposure, and the slow thermal relaxation subsequently with an approximate time constant of 120 seconds

[0044] **1C. Design Optimization:** A variety of base geometries may be considered for GPC devices according to embodiments of the invention wherein different geometries may present different advantages and disadvantages in different deployment scenarios. Within this specification two GPC designs are considered: the cylinder and the sphere. The choice of shape is important as it dictates the surface area to volume ratio of the core, which in turn directly affects the amount of heat transfer experienced in a given volume. For a sphere and cylinder of common diameter, the surface area to volume ratios are the same when the length of the cylinder is equal to its diameter. Increasing the length of the cylinder decreases the surface to volume ratio, giving it an advantage over a comparable sphere. In other applications and scenarios other designs of the core may be employed including, but not limited to, spherical, cuboid, cube, triangular prism, hemisphere, hexagonal prism, pyramid, tetrahedron, octahedron, dodecahedron, and icosahedron.

[0045] Accordingly, heat simulations were conducted to determine the number and shape of the nested graphite components, namely core, jackets, and shields, to minimize the heat transfer experienced in the core. In order to narrow the design solution space, a number of constraints were imposed on the optimization process including:

- the maximum diameter of the GPC was set to 20 mm;
- the minimum thickness of any given graphite or insulation layer was set to 0.5 mm to keep the demands of prototype fabrication and assembly at a reasonable level;
- the maximum insulation layer thickness was set to 1.0 mm so as to avoid overly large radiation field perturbation effects; and
- the mass of each outer element, e.g. jacket and shield, was set to be equal to that of the absorbing core thus minimizing the magnitude of the thermal gradients across these bodies.

[0046] However, it would be evident to one skilled in the art that other design constraints may be applied according to the target GPC requirements without departing from the scope of the invention. Within the design solution space presented with respect to the GPCs within this specification insulator materials were restricted to air, polystyrene, and a flexible aerogel-based material (e.g. Pyrogel® 2250). The relevant thermal properties of these materials are listed in Table 1. Vacuum gaps were not considered for fabricating prototypes for evaluation but it would be evident to one skilled in the art that vacuum based thermal insulation may be implemented with or without an associated pumping system. It would also be evident that other materials or combination of materials to provide the required thermal barriers wherein said materials may include solid, liquids, gels, and gases. It would be further evident that where multiple additional elements surround the core, such as depicted in Figures 2A through 3B, 5, and 6 with the shield and jacket that the thermal barrier may be different between each sequential pair of elements.

Table 1: Material Properties Used in Simulating Heat Transport in COMSOL Multiphysics FEM at 22°C

Material	Mass Density (kgm^{-3})	Specific Heat Capacity ($Jkg^{-1}K^{-1}$)	Thermal Conductivity ($Wm^{-1}K^{-1}$)
Pyrogel® 2250	170	1046	0.0155
Expanded Polystyrene	997.8	4.1823	0.6009
Air	1.194	1005	0.0259

[0047] Initial heat transfer simulations were aimed to determine the optimal number and shape of nested graphite components, e.g. core, jackets, shield, etc., in order to maximize the thermal isolation of the core. This was carried out using an axially-symmetric heat conduction model of the GPC, with an initial temperature set above ambient, varied between 23°C and 40°C, was left to reach thermal equilibrium with the surrounding environment, set to 22°C. For each

design variation, the average temperature of the core was traced as it decreased exponentially and the degree of thermal isolation was quantified by measuring the associated time constants. This approach was chosen because the aforementioned extrapolation method of determining temperature rises is only valid when the time scales over which temperature losses occur are much longer than the irradiation time, see for example Seuntjens et al in "Review of Calorimeter-based Absorbed Dose to Water Standards" (IAEA Int. Symp. on Standards and Codes of Practice in Med. Rad. Dosimetry, IAEA-CN-96-3).

[0048] A heat source defined in space and time to mimic the effects of the dose distribution deposited by a 6MV photon beam was added to the heat transport model. Accurate dose distributions perturbed by the presence of inhomogeneities were calculated using Monte Carlo techniques. The dose rate $\delta D/\delta t$ for the simulated radiation source was varied between $100\text{cGy/min} \leq \delta D/\delta t \leq 1000\text{cGy/min}$, for irradiation times ranging between 100 seconds and 1000 seconds. Heat transfer correction factors, k_{ht} , were determined by measuring the ratio of the temperature rise in the core in the absence of heat transfer to that of the realistic case. The model was further refined through the addition of thermistors, platinum alloy leads, and a poly(methyl methacrylate) stem. To simulate active thermal control, a proportional, integral, derivative (PID) controller was emulated by implementing an algorithm controlling the amount of power dissipated in the shield such that a desired set point temperature is achieved and maintained.

[0049] **ID. Monte Carlo Simulations:** A two-dimensional (2D) axially-symmetric model of the GPC inside a water phantom was simulated with the DOSRZnrc user code of the EGSnrcMP Monte Carlo (MC) code system, see Kawrakow et al in "The EGSnrc Code System: Monte Carlo Simulation of Electron and Photon Transport" (Canadian National Research Center, NRC Report PIRS-701, 2006). An inventor developed 6MV photon spectrum and an electron energy cutoff of 521keV were used. In all cases, simulations were compared to a water-only (no calorimeter present) model. A perturbation correction, k_{gap} , due to the presence of the aerogel (Pyrogel® 2250) was calculated, see for example Boutillon in "Gap Correction for the Calorimetric Measurement of Absorbed Dose in Graphite with a 60Co Beam" (Phys. Med. Biol., Vol. 34, pp1809-21) and Owen et al "Correction for the Effect of the Gaps around the Core of an Absorbed Dose Graphite Calorimeter in High Energy Photon Radiation" (Phys. Med. Biol., Vol. 36, pp1699-1704. Additionally the graphite to water absorbed dose conversion factor was calculated together with the ratio the of MC dose scored in the GPC core volume to that of an equivalent volume of water at the same depth in the absence of the detector, see for example Nutbrown et al "Evaluation of Factors to Convert Absorbed Dose Calibrations in Graphite to Water for Mega-Voltage Photon Beams" (UK National Physical Laboratory, NPL Report CIRM 37, 2000). Since both of these factors are beam-quality dependent, it would be evident that knowledge of the incident radiation spectrum is required to accurately calibrate them, and hence design simulations / design variations may therefore be required to provide the desired sensitivity / accuracy for different incident beams. The dose averaged over the volume can also be converted to absorbed dose to a point.

2. GRAPHITE PROBE CALORIMETER

[0050] **2A. Construction:** The GPC prototype according to an embodiment of the invention as depicted in Figure 2A consists of cylindrically nested components of graphite, Grade R 4340 from SGL Carbon Group, with a density of 1.27g/cm^3 with aerogel thermal insulation, Pyrogel® 2250 from Aspen Aerogels, Inc. Two negative temperature coefficient thermistors with a nominal resistance of $10\text{k}\Omega$ at 25°C and a bead diameter of 0.5mm were fixed to the core. The 6.3mm long platinum alloy thermistor leads were covered by polyimide tubing with an inner diameter of 0.18mm were threaded through 0.5mm diameter holes in the jacket and shield caps allowing for electrical connections to be made to a shielded, two-lead cable outside the body, as depicted in Figure 2B. For the jack and shield, a high purity (99%) graphite adhesive, 931 from Cotronics Corp., was used to fasten the end caps to the hollow cylinder body. A Poly(Methyl Methacrylate) (PMMA, also known as Lucite) stem was fabricated to encapsulate and waterproof the GPC for submerged dose measurements as depicted in Figure 2C. This PMMA stem also serves as a rigid shell protecting the electrical connections from the physical strain of handling. Active thermal stabilization of the shield was not incorporated into the GPC prototype because the aim of the initial measurements was to establish a baseline of its performance, a worst case scenario, when operated in the clinical setting. However it would be evident to one skilled in the art that thermal stabilization may be implemented within a GPC according to an embodiment of the invention.

[0051] **2B. Absorbed Dose Measurements:** Initial absorbed dose to water measurements made using the GPC prototype according to an embodiment of the invention were performed using a Novalis Tx radiosurgery system. The GPC was positioned horizontally inside a $30 \times 30 \times 6\text{cm}^3$ water-equivalent phantom with 1.55cm thick water-equivalent buildup. This entire setup was placed in front of a horizontally oriented 6MV stereotactic radiosurgery mode photon beam at 1000 MU/min dose rate and source-skin distance (SSD) of 100cm . A field size of $10 \times 10\text{cm}^2$ was used throughout the experiments. The GPC was irradiated for 12, 20, 30 and 60 seconds amounting to doses of 200, 333, 500 and 1000 monitor units (MU) respectively. Raw signals acquired were the voltage output of an active bridge type circuit. Bridge voltage was related to relative change in thermistor resistance through ohm-calibrations, see Figure 4B, which were in turn related to a temperature rise using a thermistor calibration curve. The corresponding dose to graphite measurements

were then corrected for heat transfer and radiation perturbation effects and converted to water dose using MC calculated data.

[0052] In a second series of measurements twenty-five (25) absorbed dose to water measurements were made using the GPC with the same 6MV photon beam and Novalis Tx radiosurgery system. The GPC was positioned vertically and coincident with the central beam axis at a depth of 5.0cm inside of a $30 \times 30 \times 30\text{cm}^3$ temperature controlled water phantom at a source-to-surface distance (SSD) of 107.3cm. The water set-point temperature was set to 24°C and left to stabilize overnight. Temperature control was shut-off before performing absorbed dose measurements at dose rates of 400 and 1000MU/min. A collimator setting of $10 \times 10\text{cm}^2$ was used throughout the experiments. As previously stated, raw calorimetric signals acquired were the voltage output of an active bridge type circuit, wherein such a raw calorimetric signal being depicted in Figure 4C.

[0053] As noted *supra* and depicted in Figure 4B the bridge voltage was related to a relative change in thermistor resistance through Ohm-calibrations conducted during the experimental session. The change in thermistor resistance was in turn related to a temperature rise using a prior-measured thermistor calibration curve. The corresponding dose to graphite measurements were then corrected for heat transfer and radiation field perturbation effects and converted to water dose using MC-calculated data. GPC-acquired dose to water values were compared against dose to water measurements made with an Exradin A12 ionization chamber (Standard Imaging Inc.) with a calibration traceable to a primary standards laboratory (National Research Council of Canada), following the AAPM TG-51 protocol, see for example Almond et al in "AAPM TG-51 Protocol for Clinical Reference Dosimetry of High Energy Photon and Electron Beams" (Med. Phys., V1. 26, pp.1847-1870).

3. RESULTS:

[0054] **3A. Graphite Probe Calorimeter:** Referring to Figure 3A and 3B there are depicted a schematic diagram and X-ray microtomography (microCT) scan of the resulting GPC design as discussed above in respect of sections 1A through 1F according to an embodiment of the invention. The GPC is made up of three concentric cylinders, the first being the 6.10mm diameter by 10.00mm long graphite core is separated from a second 0.70mm thick jacket cylinder by a 0.70mm isotropic layer of insulation. Likewise, a further 1.00mm layer of insulation thermally isolates the jacket from a 1.00mm thick graphite shield. The aerogel was selected as the insulator due to its relatively low thermal conductivity and its ease of manipulation.

[0055] **3B. Measurements: $30 \times 30 \times 6\text{cm}^3$ Water-Equivalent Phantom:** A summary of the results of initial experiments performed by delivering 200, 333, 500 and 1000 MU, at a rate of 1000 MU/min, are shown in Tables 2 and 3 below. The uncertainty in each column represents one standard deviation on those measurements. Since the calorimetric measurements were performed for different irradiation times, Table 1B also lists the calculated doses per 100 MU delivered, averaged over all measurements. The maximum absolute percent difference of measured dose to water with the GPC and that measured based on the Task Group 51 of the American Association of Physicists in Medicine (AAPM TG-51) using a tertiary reference chamber was 2.8%, a tenth of a percent larger than the estimated combined relative standard uncertainty (2.7%) of the measurements as outlined in Table 2 below. All other measurements agreed with the expected dose values within this total uncertainty.

Table 2: Summary of GPC Measurements for various MU Deliveries

Delivered MU	Number of calorimetric runs performed	Average temperature rise (mK)	Average heat loss corrected dose to graphite (cGy)
200	2	2.47 ± 0.01	178.8 ± 0.6
333	5	3.98 ± 0.03	287.3 ± 2.4
500	3	6.08 ± 0.01	437.8 ± 0.9
1000	2	11.95 ± 0.01	858.9 ± 1.1
Total average per 100 MU	12	1.21 ± 0.02	87.1 ± 1.2

Table 3: Summary of Dose Measurements for various MU Deliveries

Delivered MU	Average dose to water (cGy)	TG-51 measured dose to water (cGy)	% Difference of experiment from TG-51
200	196.5 ± 0.7	193.2	+1.7
333	315.8 ± 2.7	321.6	-1.8
500	480.0 ± 1.0	482.9	-0.6
1000	948.2 ± 1.2	965.8	-1.8
Total average per 100 MU	95.7 ± 1.4	96.6	-0.9

3C. Measurements: 30 × 30 × 30cm³ Water Phantom:

[0056] A summary of the results of the experiments performed by delivering 200 and 333 MU, at a rate of 400 and 1000 MU/min, respectively, are shown in Table 4, for the GPC disposed within the 30 × 30 × 30cm³ water phantom. The uncertainty in each column represents one standard deviation on those measurements. Table 4 also lists the averages of all quantities measured normalized to a delivery of 100 MU over the 25 measurements performed. The maximum percentage difference between a dose to water measured using the GPC and the corresponding TG-51 derived value was 2.2%. A clear trend was observed between the accuracy of dose measurement and the stability of the water bath temperature. During the first hour of measurement, the water temperature was stable to within 2 mK and the average discrepancy between the GPC and the ion chamber was 0.6%. During the last hour of measurement, the water was cooling at a rate of about 15 mK/h and the average discrepancy increased to 1.5%

Table 4: Dose Measurement Summary using GPC for Different MU Deliveries

Delivered MU	Number of Calorimetric Measurements	Average Temperature Rise (mK)	Average Heat Loss Corrected Graphite (cGy)	Average Dose to Water (cGy)	TG-51 Calculated Dose to Water (cGy)	% Difference of Experiments to TG-51
333	20	2.99±0.02	213.9±1.2	241.8±1.4	244.4	+1.2
200	5	1.79±0.01	128.1±0.6	144.8±0.6	145.1	+0.2
Average per 100MU	20	0.90±0.0 1	64.2±0.4	72.6±0.4	73.2	+0.9

[0057] Percentage difference in last column of Table 4 is given by Equation (2).

$$\%Difference = \frac{TG51 - CalculatedDose - MeasuredDose}{TG51 - CalculatedDose} \times 100 \quad (2)$$

3D. Linearity Measurements:

[0058] Referring to Table 5 the linearity of a GPC according to an embodiment of the invention, as described supra in respect of Figures 1A to 3B, is presented based upon measurements using the same 30 × 30 × 30cm³ water phantom as exploited and discussed supra in respect of Section 3C. As evident from the data presented the GPC provides high linearity over dosage ranges from approximately 6cGy to approximately 660cGy based upon the characteristics of the design. Accordingly, it would be evident to one skilled in the art that the design of the GPC may be tailored to a particular dose range, beam profile, response rate, as well as linearity.

Table 5: Linearity Data for GPC using $30 \times 30 \times 30\text{cm}^3$ Water Phantom

Irradiation Duration (s)	Measured Dose in Graphite (cGy)	Ratio of Dose Duration to 60 Second	Ratio of Irradiated Dose to that of 60 second Duration
60	658.33	1	1
30	329.09	0.5	0.49989
30	328.89	0.5	0.49958
0.6	6.56	0.01	0.00996
0.06	0.48	0.001	0.00073

[0059] 3E. Dose to Water Measurement Uncertainties: In an effort to identify where the measurement differences of GPC experiments to TG-51 reference a breakdown of the estimated uncertainty budget, listing the largest contributing types A and B uncertainties used in the data analysis, was assembled. It is important to note that the uncertainty budget shown in Table 6 is meant to provide a high-level perspective and should not be considered complete but does indicate potential areas for improvement. Although the heat transfer corrections are likely to be near unity for this setup, their dependencies have not yet been fully evaluated and require a detailed sensitivity analysis. As such, this quantity has been assigned a standard uncertainty of 0.5% in accordance with the methodology of Sander, see Sander et al. in "NPL's New Absorbed Dose Standard for the Calibration of HDR192Ir Brachytherapy Sources" (Metrologia, Vol. 49, pp.S184-S188.17). The reproducibility represents one standard deviation of the raw mean. The Ohm and thermistor calibrations reflect the uncertainty in the fits of their respective curves.

[0060] Since the specific heat capacity of the graphite used in the GPC's construction is unknown, a standard value with a rectangular distribution of $715 \pm 10 \text{ Jkg}^{-1}\text{K}^{-1}$ at 24°C was used based on the experimentally determined values using pure graphite from the literature, see for example Alberts et al. "CRC Handbook Of Chemistry and Physics" (87th Ed., CRC, Cleveland, 1976) and Picard et al in "Determination of the Specific Heat Capacity of a Graphite Sample using Absolute and Differential Methods" (Metrologia, Vol. 44, pp.294-302). The positioning refers to the effect of the uncertainty in the GPC depth measurements. Finally, the perturbation-dose conversion refers to the statistical uncertainty in the Monte-Carlo simulations used to calculate this quantity.

[0061] On the other hand, the relative uncertainty associated with the TG-51 measurements is estimated to be 0.9% ($k = 1$). This value was determined from the 0.7% uncertainty on the value of $N_{D,w}$ provided by the standards laboratory, 0.5% uncertainty on the beam quality conversion factor k_Q , see for example Rogers "The Physics of AAPM's TG-51 Protocol" (Clinical Dosimetry Measurements in Radiotherapy, Medical Physics Monograph No. 34, Medical Physics Publishing, pp.239-298), and 0.4% total uncertainty associated with P_{POL}, P_{ION}, P_{TP} , humidity, depth setting, and leakage current.

Table 6: Estimated Uncertainty Budget for GPC in High-Energy Photon Beam Water Dose Measurements

Quantity	Type A % uncertainty	Type B % uncertainty
Heat transfer correction	---	0.5
Reproducibility	0.6	---
Ohm calibration	---	0.5
Thermistor calibration	---	0.2
Specific heat capacity	---	0.8
Positioning	0.2	---
Perturbation-dose calibration	---	0.4
Other uncertainties not considered in this work	---	0.4
Quadratic summation	0.6	1.2
Combined relative standard uncertainty in dose to water	1.4	

[0062] 3F. Corrections and Dose Conversion: Conductive heat transfer corrections, k_{ht} , calculated using a three-dimensional model of the GPC submerged in a constant temperature water phantom were determined to be 1.001 and

1.002 for the 20s and 30s irradiations, respectively. The effects of convection in the water phantom are assumed to be negligible. A Monte Carlo-calculated dose distribution for this experimental setup was used as a heat source input parameter in the heat transport model. The product of the radiation field perturbation factor and the graphite to water dose conversion factor was determined using MC to be 1.130 ± 0.005 .

4. DISCUSSION

[0063] The results in Tables 2-4 demonstrate the feasibility of performing absolute clinical photon dose measurements using the GPC. The reproducibility achieved in this work is similar to the 0.6% estimated by Duane with a small-scale IMRT calorimeter, see Duane et al. in "An Absorbed Dose Calorimeter for IMRT Dosimetry" (Metrologia, Vol. 49, pp.S168-S173). There are areas however, that would benefit from improvement for the devices to become routine clinical dosimeters.

[0064] As expected, the observed relation between temperature stability and measurement accuracy suggests that clinical use of the GPC will probably require it to be able to provide its own stable background temperature against which a temperature rise can be measured. The discrepancies observed between the GPC and TG-51 are partly due to the fact that the heat loss correction applied to the measured dose to graphite has been calculated assuming a stable surround temperature. In reality, the water in the tank is slowly drifting toward room temperature. As these thermal gradients increase in magnitude, the less adequate the heat transfer correction becomes. Accordingly, developing a proportional-integral-derivative (PID) temperature controller algorithm and associated electronic circuitry may be required to operate in the isothermal mode such as employed in other prior art calorimeters, see for example Daures et al in "New Constant-Temperature Operation Mode for Graphite Calorimeter at LNE-LNHB" (Phys. Med. Biol., Vol. 50, pp.4035-4052). With such a PID controller the measured quantity is the power dissipated in the core to maintain a set point temperature. Benefits of an isothermal mode include an increased reproducibility, decreased initialization time and delay time between measurements, and the ability to operate at higher dose rates than achievable when operating in the quasi-adiabatic radiation mode. Furthermore, the calibration procedure discussed supra, i.e. voltage to resistance and resistance to temperature, will become unnecessary in this mode with a priori knowledge of the core mass.

[0065] As a result, the ohm calibration (0.5%), thermistor calibration (0.2%), and specific heat capacity (0.8%) sources of type B uncertainty are replaced by the uncertainty of a mass measurement, which is expected to be no more than a few tenths of a percent. While an overall uncertainty of 1.4% was estimated for the dose measurements in this work, it is hypothesized that this can be reduced to well below 1.0% if operating in isothermal mode. With the potential for automated data analysis, the GPC could be made to be a battery-powered, absolute clinical dosimeter that could store and wirelessly transmit the measured dose values and automatically notify the user of an out-of-specification reading without anyone having to manually measure and recognize faulty values.

5. ALTERNATE EMBODIMENTS

[0066] Accordingly, as discussed supra, isothermal mode operation may be beneficial in some embodiments of the invention. Referring to Figures 5A through 7B, there are depicted alternative embodiments of the invention employing resistive heating elements within different portions of the GPC together with resistive sensing elements disposed upon or within the graphite core.

[0067] Figure 5A depicts a circularly symmetric GPC with resistive sensor elements deposited upon the outer surface of the graphite core and resistive heating elements deposited onto the inner surface of the jacket.

[0068] Figure 5B depicts a circularly symmetric GPC with resistive sensor element embedded within the graphite core and resistive heating elements deposited onto the inner surface of the jacket.

[0069] Figure 5C depicts a circularly symmetric GPC with resistive sensor element embedded within the graphite core and resistive heating elements embedded within the jacket.

[0070] Figure 6 depicts a rectangular GPC with multiple resistive sensor elements deposited upon the outer surface of the graphite core and heater elements are deposited onto the inner surface of the jacket.

[0071] Figure 7A depicts a circularly symmetric GPC with resistive sensor elements embedded within the graphite core which is held within a vacuum environment formed through the sealing of a low thermal conductivity glass rod, which is attached to the graphite core, to the ceramic outer jacket using a low temperature glass frit based sealing process.

[0072] Figure 7B depicts a GPC according to an embodiment of the invention with wire wound heaters formed around the graphite core and resistance element within the graphite core.

[0073] It would be evident to one skilled in the art that the temperature dependent resistive sensor elements formed on the graphic core may be thin film thermocouples formed by vacuum deposition. These foreign (non-graphite) materials may be used in amounts that do not make them affect the measurement of the principal quantity, i.e., dose to graphite. Thermocouples may employ for example nickel, iron, copper, constantan, Chromel and Alumel as metal elements. Alternatively they may be platinum or nickel resistance temperature detectors (RTDs), semiconductor thermistors, or

sintered metal oxide thermistors. They may exhibit positive or negative temperature coefficients. Similarly the heater elements may be formed from metals including, but not limited to platinum, nikeline, constantan, manganin, nickel-chrome (nichrome), and copper. It would also be evident that the shield and / or jacket may be formed from other materials according to the overall thermal and mechanical design constraints. Such materials may include, but not be limited to, quartz, glass, ceramic, borosilicate glass, alumina, aluminum nitride, mullite, and beryllia. All such materials may be metalized for formation of the heating elements within the GPC. It would also be evident that according to design and manufacturing variations that temperature sensing elements may be formed within the core as well as on the outer surface of the core and that the core may be formed from multiple elements as well as a single element.

[0074] Accordingly, the jacket, and potentially the shield as well, may contain resistive heating elements, which are actively controlled to maintain a constant higher-than-ambient temperature. By maintaining a constant jacket temperature, thermal equilibrium across the encased calorimeter components will be achievable, thus minimizing heat loss from the core. While some heat transfer in the core is inevitable due to inherent dose gradients, it is expected that active thermal stabilization should sufficiently minimize this effect such that the repeatability of the radiation-induced temperature rise is improved to within a few tenths of a percent. Additionally as evident from Figure 6 it would be evident that segmented heaters operating in conjunction with multiple thermal sensor elements on the core may provide for more complex control and feedback methods, see for example Daures. According to other embodiments of the invention, heater elements and RTD elements may be formed onto the core together such that thermal stability is achieved through one set of RTD elements providing feed-back to a thermal controller driving the heater elements before a second set of RTD elements are read for the dose measurement. If a long thermal time constant exists for the GPC relative to the dose regimen being implemented then the heating circuit may be disabled for the duration of the measurement to reduce noise and control artifacts within the measurements.

[0075] Thermistor calibration in a computer-controlled variable water bath can render calibration of the device to an uncertainty of 0.2 - 0.3%, as has been demonstrated with thermistors used in Domen-type water calorimeters, see for example Stewart in "The Development of New Devices for Accurate Radiation Dose Measurement: A Guarded Liquid Ionization Chamber and an Electron Sealed Water Calorimeter" (Ph.D. Dissertation, McGill University, 2007). In short, calibration is achieved by dissipating an accurately known amount of electrical energy into the core in the absence of radiation and measuring the resulting response of the active bridge circuit, thus directly relating energy absorbed to bridge voltage. This mode of operation has the added advantage of not requiring a priori knowledge of the specific heat capacity of the absorber medium. By developing a calibration process based on the quasi-adiabatic electrical mode of operation, the ohm-calibration, thermistor calibration and specific heat capacity sources of Type B uncertainty can be replaced by a single electrical calibration uncertainty.

[0076] Accordingly, a GPC according to embodiments of the invention could be made to be a battery-powered, self-calibrating dosimeter that could notify the user of an out-of-specification response without anyone having to manually measure faulty values. Such an integrated stand-alone GPC being depicted in Figure 8 wherein integrated heaters and RTDs are couple to heater and RTD circuits respectively which are themselves coupled to a microprocessor controller executing a program determining feedback to the heater circuit and deriving dose measurements from the RTD measurements. This dose data may be stored within integrated memory to the microprocessor or a separate memory. Additionally the microprocessor communicates with an interface, which may for example be a wired interface such as 12C for example, or a wireless interface such as Bluetooth, allowing transfer of dose data from the GPC as well as downloading of new program data, calibration data etc. Optionally, the GPC may be used for Quality Assurance of an intended radiotherapy regimen. Accordingly the microprocessor may receive the radiotherapy regimen profile of dose versus time, measure the actual regimen and determine whether the required regimen profile was achieved or not. Optionally, the GPC may simply stream dose versus time data to a remote controller for data logging, regimen verification, etc.

[0077] It would be evident that whilst a microprocessor based controller is described in respect of Figure 8 that alternatively designs employing field-programmable gate array (FPGA) or complex programmable logic device (CPLD) architectures are feasible. In some instances a direct RTD read circuit may be provided within an FPGA or CPLD with only a small block consumption overall within the circuit.

[0078] Alternatively an integrated GPC such as depicted in Figure 8 may be designed for interconnection via a standard connector, e.g. micro-USB, allowing the GPC to be directly powered, c.f. USB 2.0 specification, and data logged during operation from a host computer such as a laptop or smartphone. Alternative embodiments of the invention exploiting thin-film temperature sensing elements, thin-film heaters, thick-film heaters, thermistors, RTDs, etc. may be formed with different geometries according to different mechanical and thermal constraints needs based on dose ranges, dose rate, radiation delivery type, and radiation type. Similarly, as depicted in Figure 9 an integrated GPC may be designed to be self-contained with a battery and supporting a wireless interface, such as for example Bluetooth, IEEE 802.11, IEEE 802.15, Zigbee, and Wireless USB allowing the integrated GPC to automatically connect to a local area network or personal area network to communicate all dose measurements or only those that fall outside a predetermined range programmed into the GPC controller. Such integrated GPC's may be charged / recharged through the standard connector in the design depicted in Figure 8 or through a wireless / inductive interface in addition to the one supporting data

communications such as depicted in Figure 9. It would also be evident that the integrated GPC may store multiple measurements prior to their transmission via a wired / wireless interface. Further, in Figure 9 a dedicated PID Controller interfaces with the heater circuit with feedback from first and second RTD circuits, one coupled to the RTD within the graphite core and the other coupled to RTDs on the inner surface of the shield upon which the heaters are also disposed. As discussed *supra* multiple heater elements and RTDs for example may be employed in conjunction with each other to provide distributed heating, temperature feedback, and temperature sensing for dose measurement.

[0079] Alternatively, as depicted in Figure 10 multiple graphite cores may be disposed within a common jacket and shield, in this instance vertically although horizontally and / or 3D arrays may be also implemented. Each graphite core has disposed, in this instance, a resistive element upon the outer surface to provide temperature measurement (although as discussed *supra* other configurations may be employed together with others not presented in Figures). Additionally, multiple heater elements are disposed on the inner surface of the jacket, as opposed to a single heater element, aligned with each graphite core such that adjustment of graphite core's via said heaters may be controlled together, individually, in associated groups, or multiple associated groups wherein a single heater may for example be associated with 2 or more groups (e.g. the third heater in a linear array may be associated with element groups (1,2,3); (2,3,4); and (3,4,5). Also disposed on the inner surface of the shield is a shield resistive element providing temperature dependent resistance data to a PID controller, heater controller, microprocessor, or other control system.

[0080] Within the preceding discussions in respect of embodiments of the invention and in respect of Figures 1A through 10 temperature sensing elements within the various embodiments have been described primarily on the basis that these are resistive structures, i.e. having resistance R . However, it would be evident to one skilled in the art that these may alternatively be capacitive with capacitance C , inductive with inductance L , LC circuits, or RLC circuits such that, for example, the frequency offset of a resonant circuit with temperature or impedance with temperature may form the basis for temperature measurement. In some embodiments of the invention, such as a spiral inductor, an external antenna may be used to electromagnetically excite the spiral inductor wherein the impedance variations of the external antenna exciting the spiral inductor will depend upon the temperature of the spiral inductor. Accordingly, the graphite core may be embedded within an insulator without any external connection for temperature sensing.

[0081] Specific details are given in the above description to provide a thorough understanding of the embodiments. However, it is understood that the embodiments may be practiced without these specific details. For example, circuits may be shown in block diagrams in order not to obscure the embodiments in unnecessary detail. In other instances, well-known circuits, processes, algorithms, structures, and techniques may be shown without unnecessary detail in order to avoid obscuring the embodiments.

[0082] The foregoing disclosure of the exemplary embodiments of the present invention has been presented for purposes of illustration and description. It is not intended to be exhaustive or to limit the invention to the precise forms disclosed. Many variations and modifications of the embodiments described herein will be apparent to one of ordinary skill in the art in light of the above disclosure. The scope of the invention is to be defined only by the claims appended hereto, and by their equivalents.

[0083] Further, in describing representative embodiments of the present invention, the specification may have presented the method and/or process of the present invention as a particular sequence of steps. However, to the extent that the method or process does not rely on the particular order of steps set forth herein, the method or process should not be limited to the particular sequence of steps described. As one of ordinary skill in the art would appreciate, other sequences of steps may be possible. Therefore, the particular order of the steps set forth in the specification should not be construed as limitations on the claims. In addition, the claims directed to the method and/or process of the present invention should not be limited to the performance of their steps in the order written, and one skilled in the art can readily appreciate that the sequences may be varied and still remain within the spirit and scope of the present invention.

Claims

1. A calorimeter comprising:

- at least one core;
- a jacket surrounding the at least one core to provide thermal isolation of the at least one core from the ambient environment;
- a first thermal barrier disposed between the at least one core and the jacket; and
- a temperature sensing element thermally coupled to the at least one core, wherein the maximum diameter of the calorimeter is 20mm.

2. The calorimeter according to claim 1, wherein the calorimeter has a volume of approximately 0.6cm^3 .

EP 3 460 529 A1

3. The calorimeter according to claim 1, wherein the calorimeter has a volume of approximately 14cm³.
4. The calorimeter according to claim 1, wherein the calorimeter has a volume less than or equal to 0.6cm³.
- 5 5. The calorimeter according to claim 1, wherein the calorimeter has a volume less than or equal to 14cm³.
6. The calorimeter according to claim 1, wherein the core has a volume of approximately 0.3cm³.
7. The calorimeter according to claim 1, wherein the core has a volume less than or equal to 0.3cm³.
- 10 8. The calorimeter according to claim 1, wherein the core has a diameter of approximately 6mm.
9. The calorimeter according to claim 1, wherein the core has a diameter of less than or equal to 6mm.
- 15 10. The calorimeter according to claim 1, wherein the calorimeter has a diameter of approximately 13mm.
11. The calorimeter according to claim 1, wherein the calorimeter has a diameter of less than or equal to 13mm.
12. The calorimeter according to claim 1 comprising a plurality of cores, wherein the jacket surrounds the plurality of
20 cores and a temperature sensing element is thermally coupled to each of the cores.
13. The calorimeter according to claim 12, wherein the plurality of cores are vertically disposed within the jacket.
14. The calorimeter according to claim 13, wherein the plurality of cores are horizontally disposed within the jacket.
- 25 15. The calorimeter according to claim 1, further comprising a wireless interface configured to transfer dose data from the calorimeter to a microprocessor.

30

35

40

45

50

55

Figure 1A

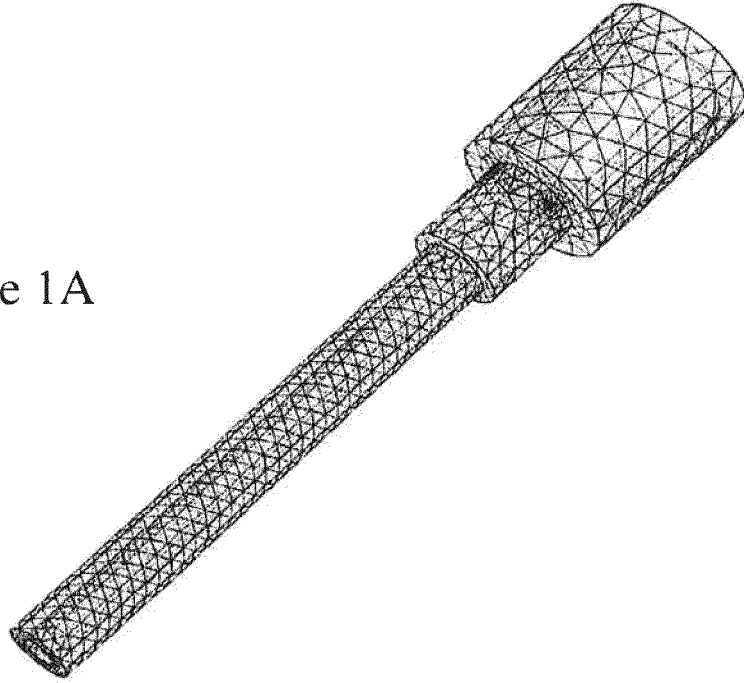
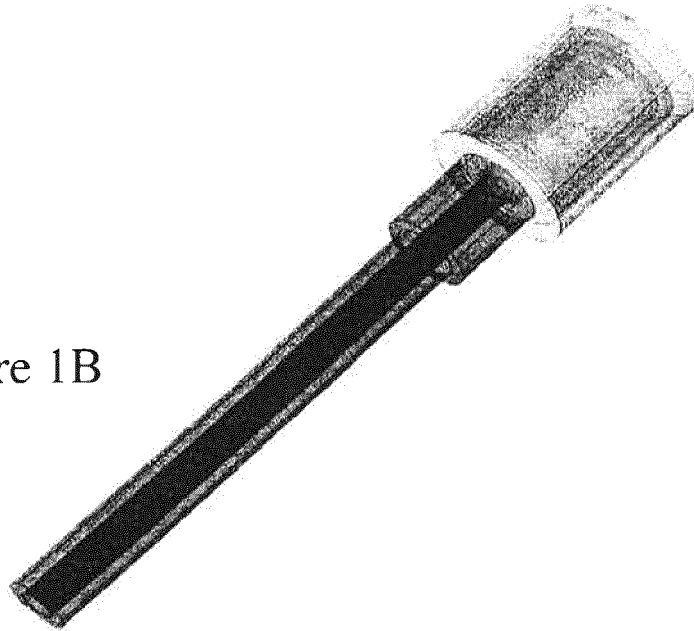

Figure 1B



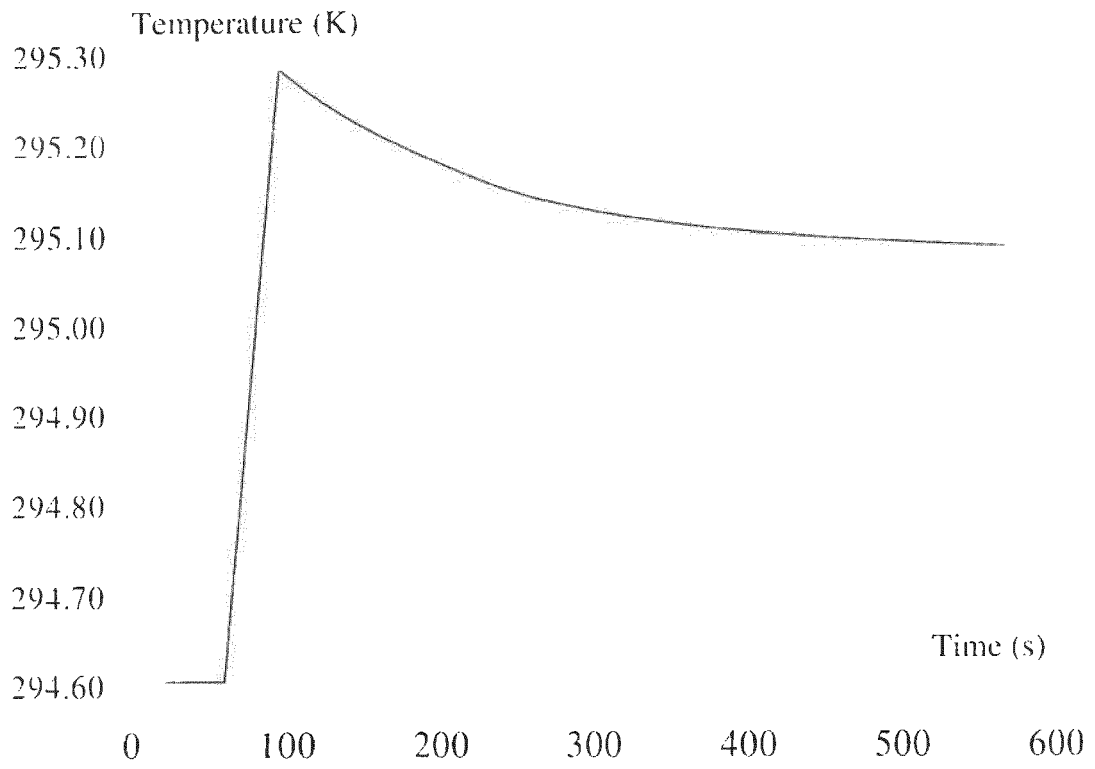

Figure 1C

Figure 2A

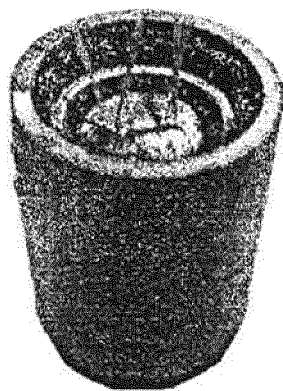

Figure 2B

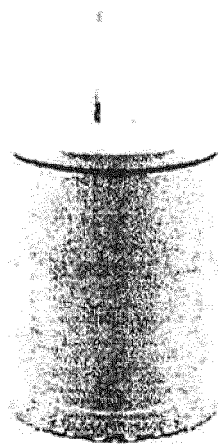



Figure 2C

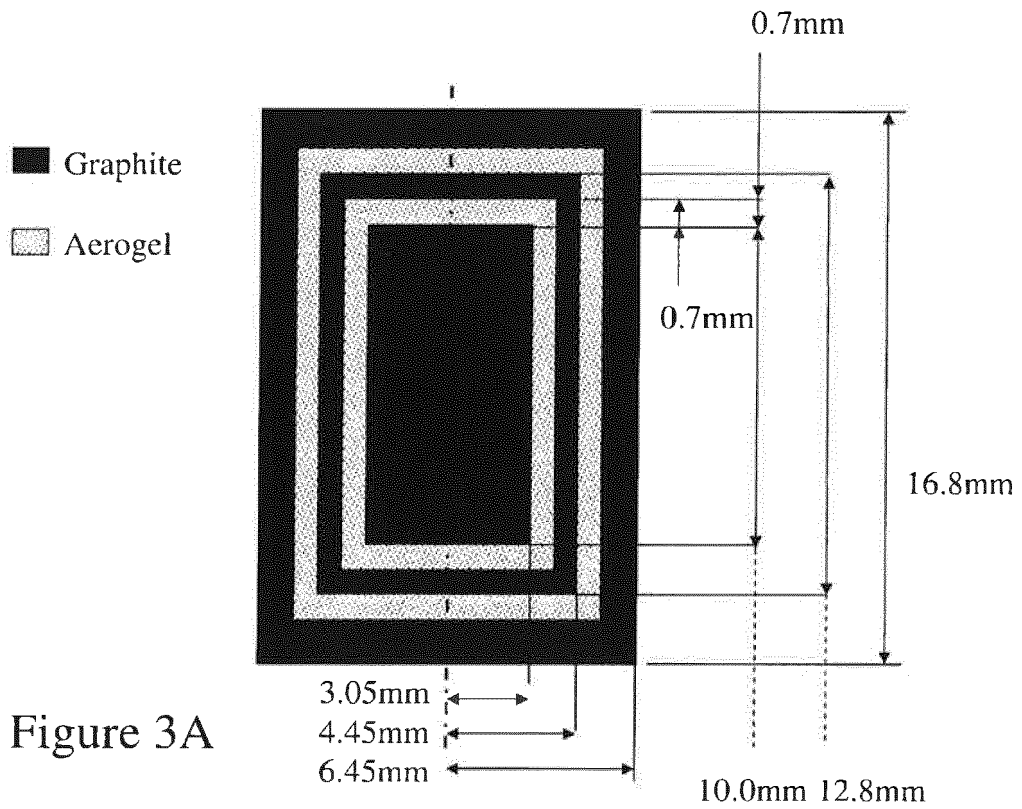

Figure 3A

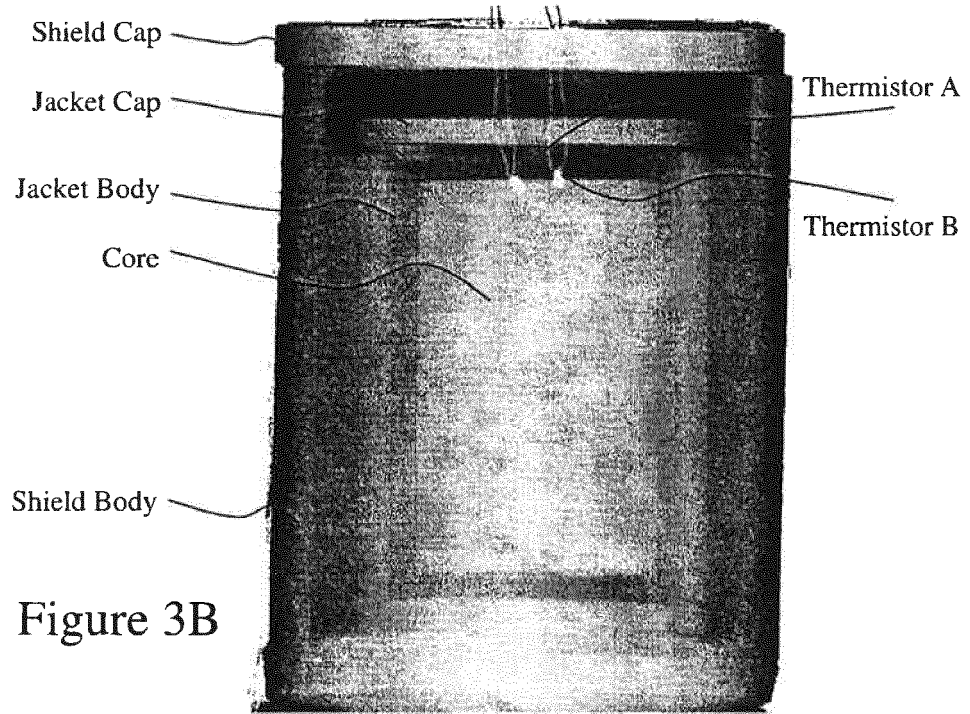

Figure 3B

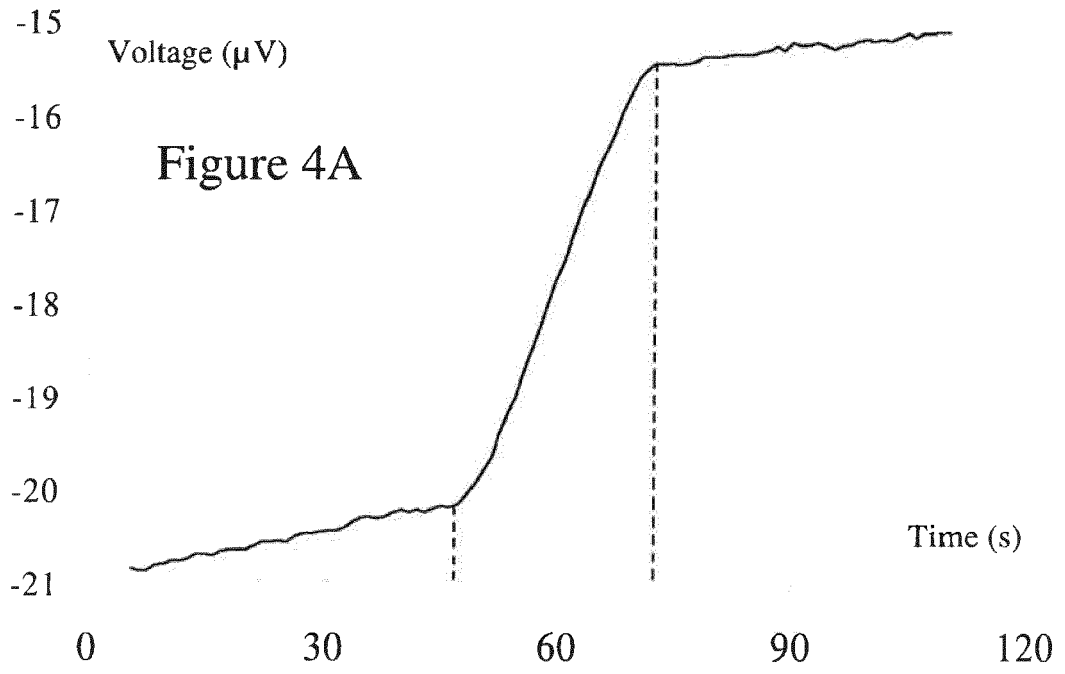

Figure 4A

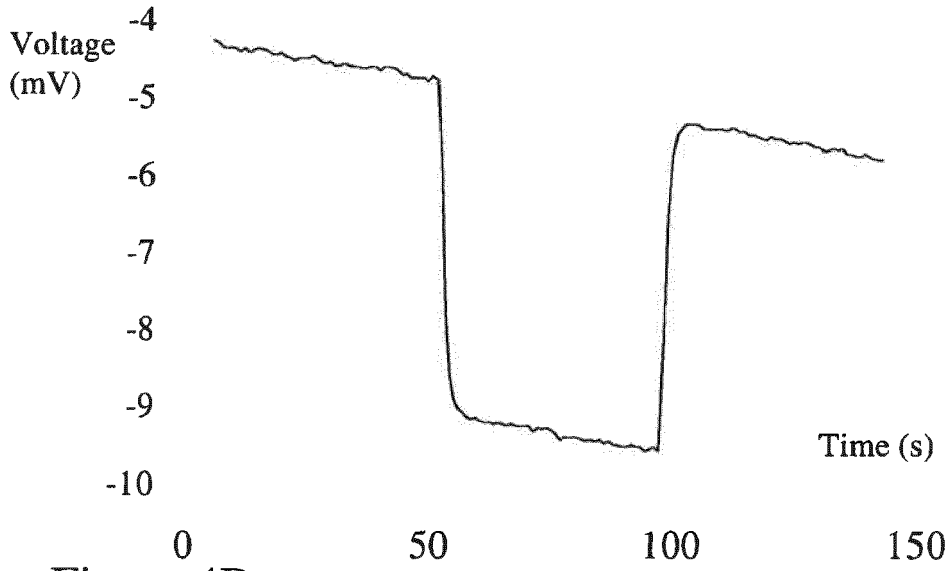

Figure 4B

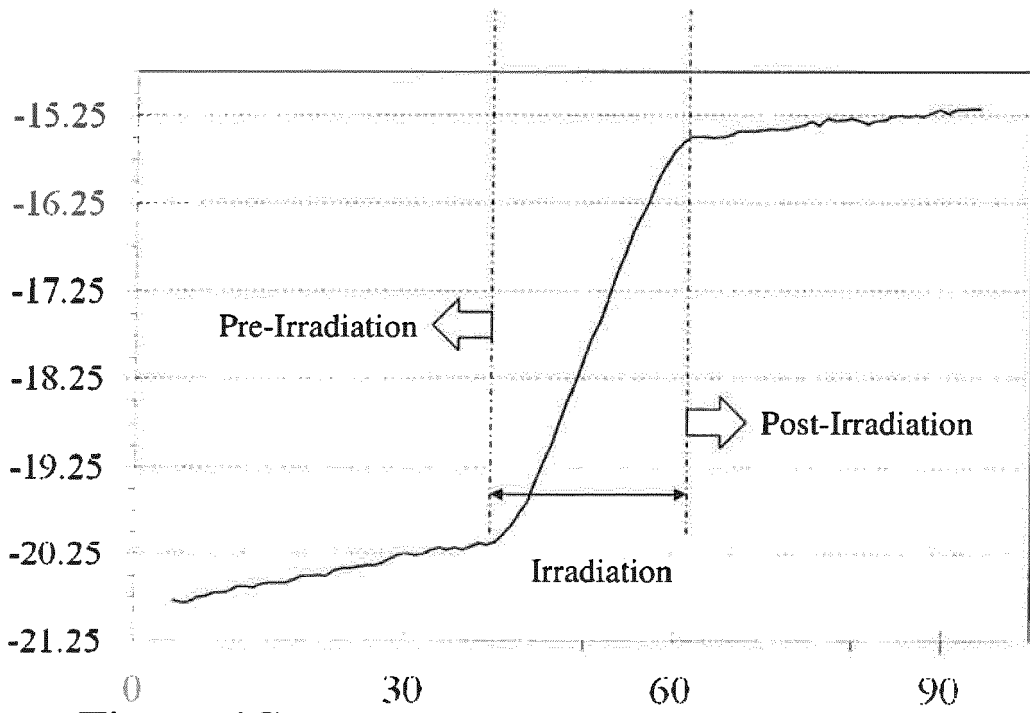

Figure 4C

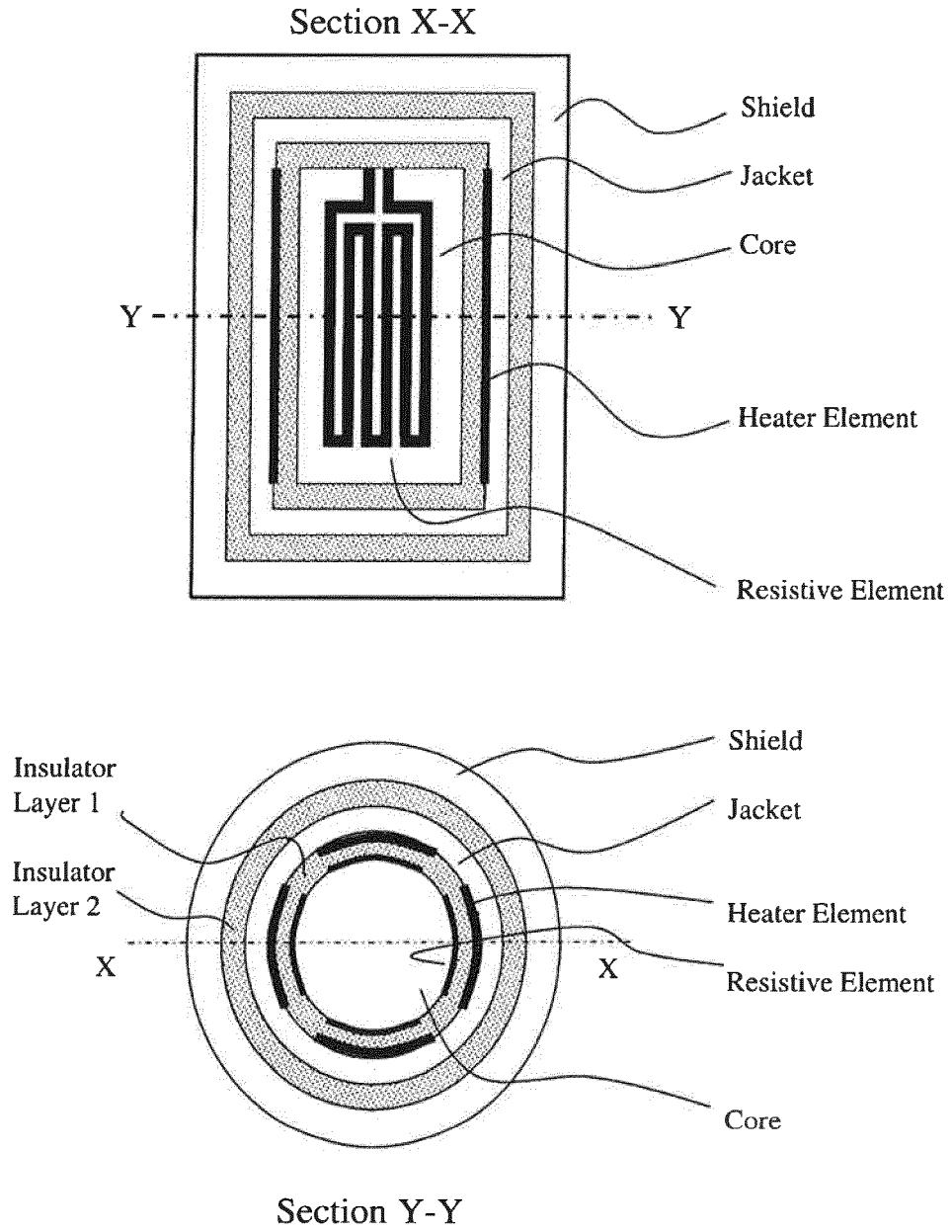

Figure 5A

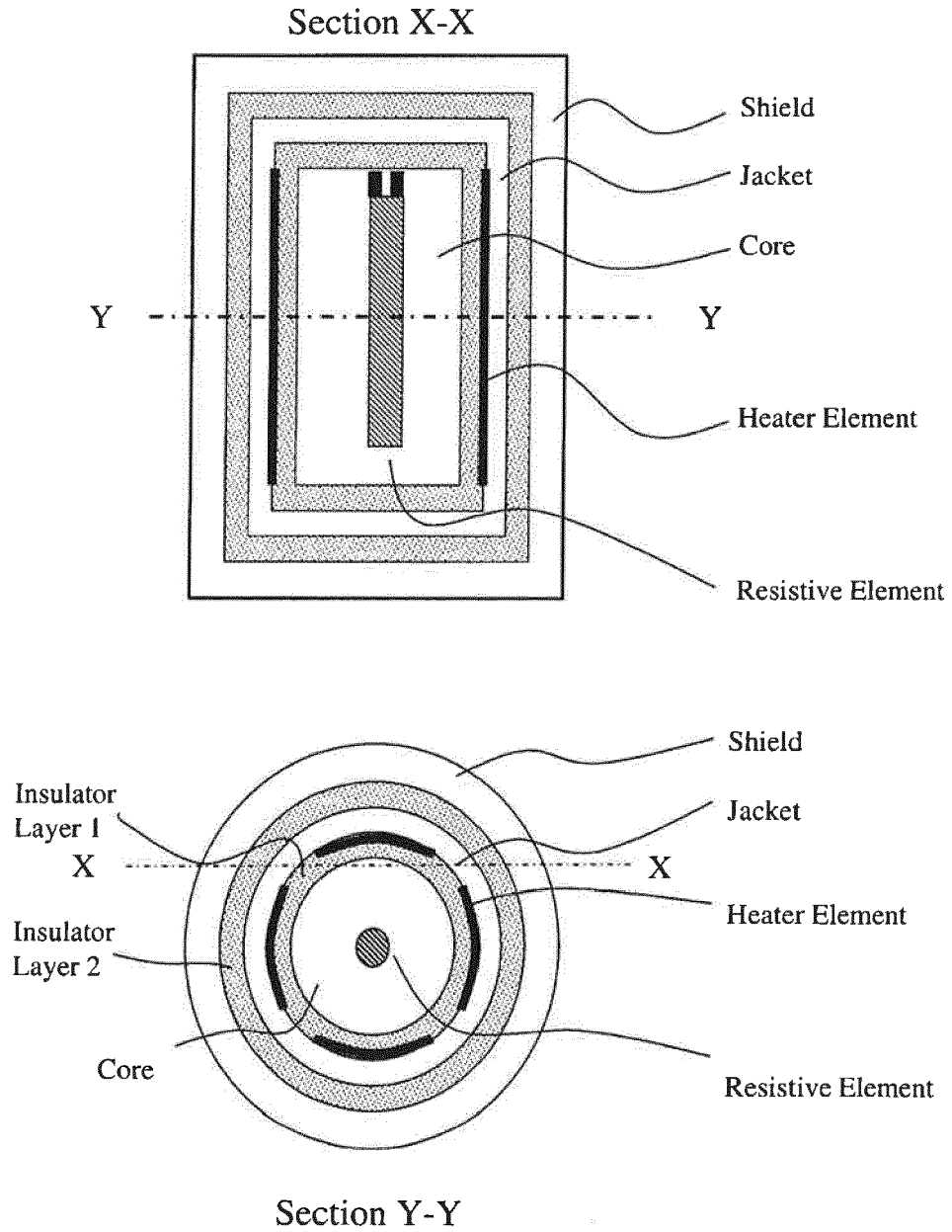

Figure 5B

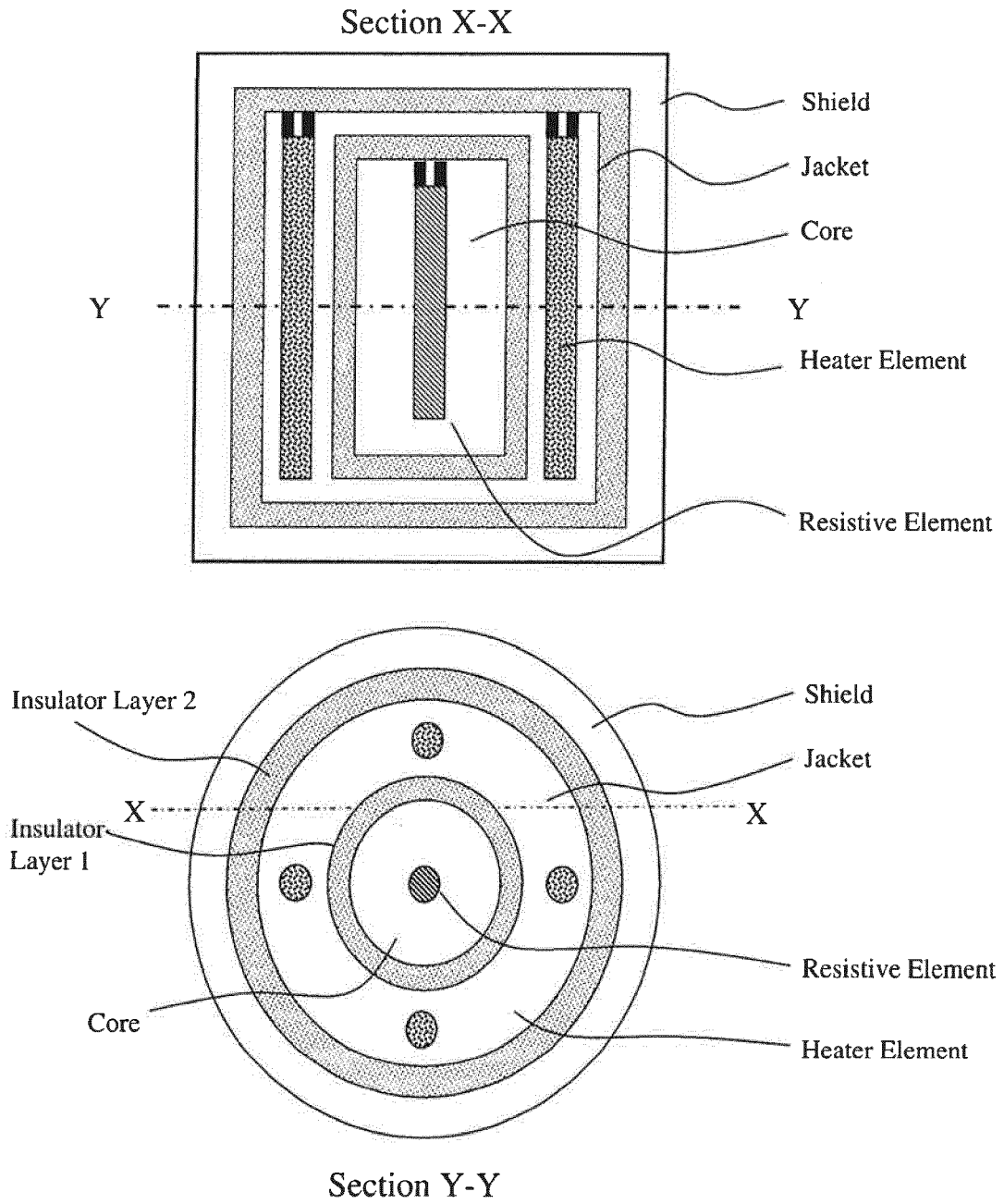

Figure 5C

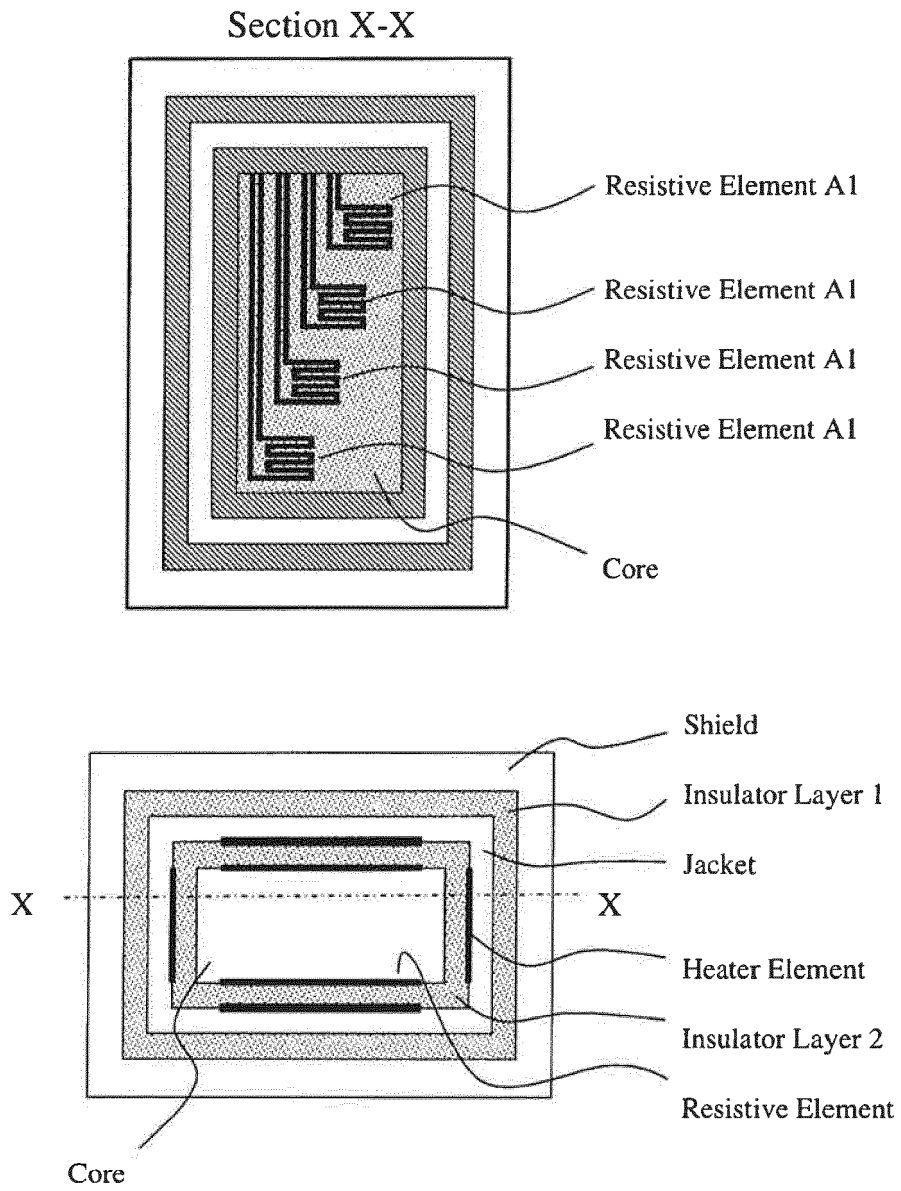

Figure 6

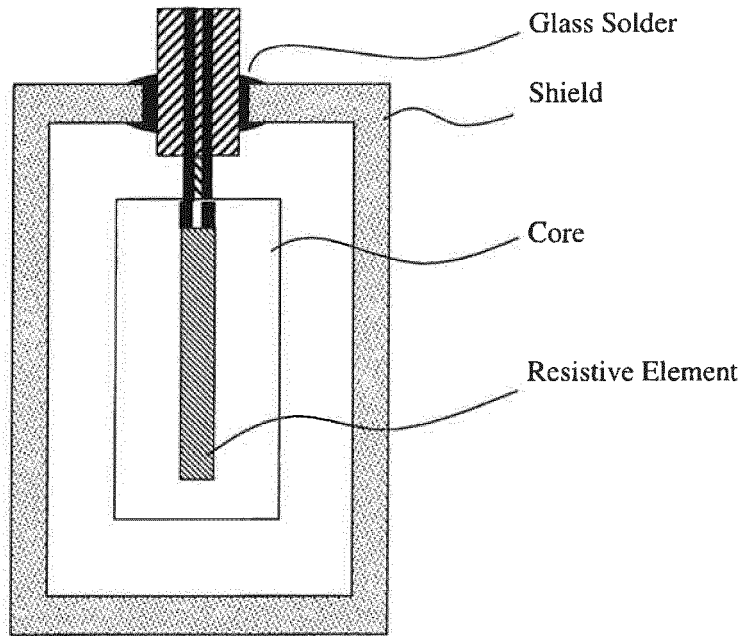

Figure 7A

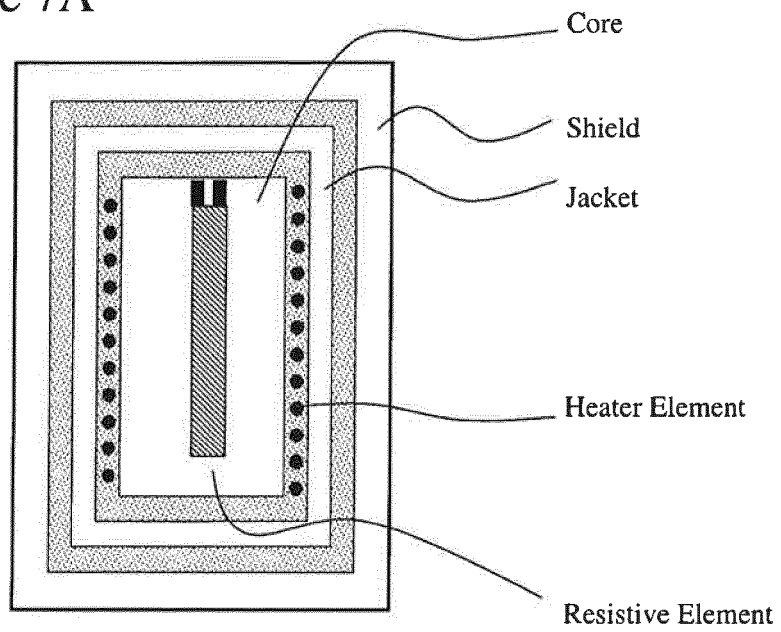

Figure 7B

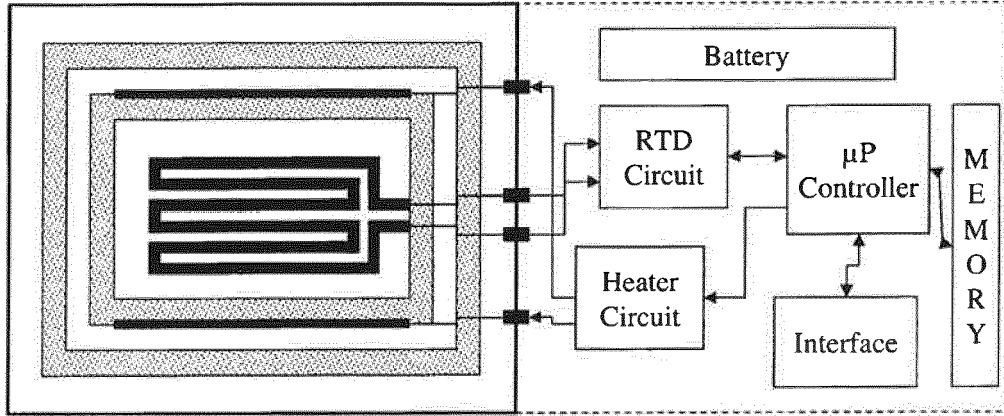

Figure 8

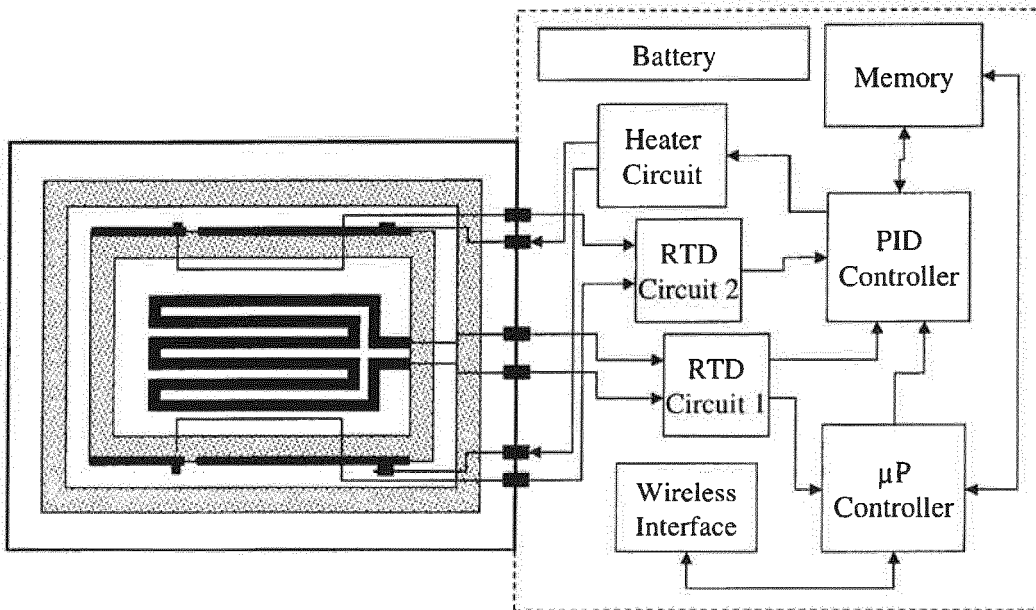

Figure 9

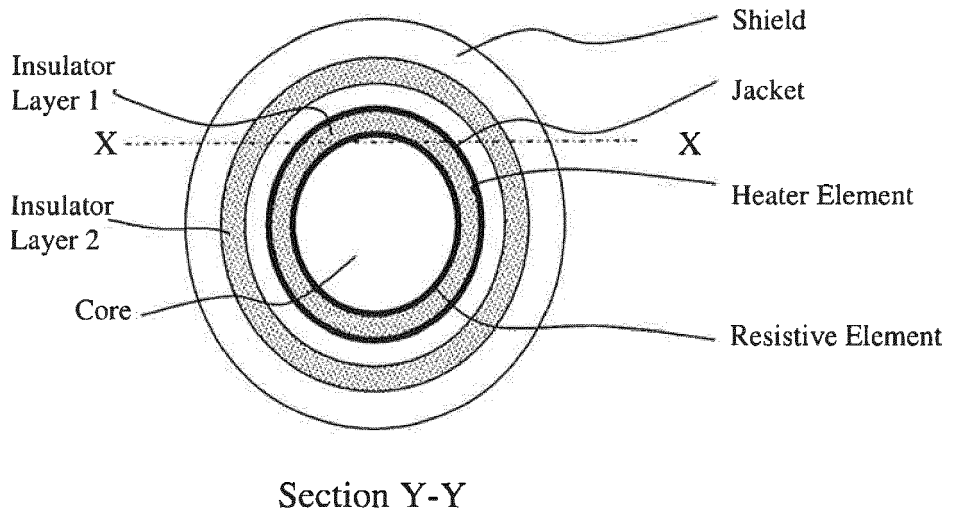
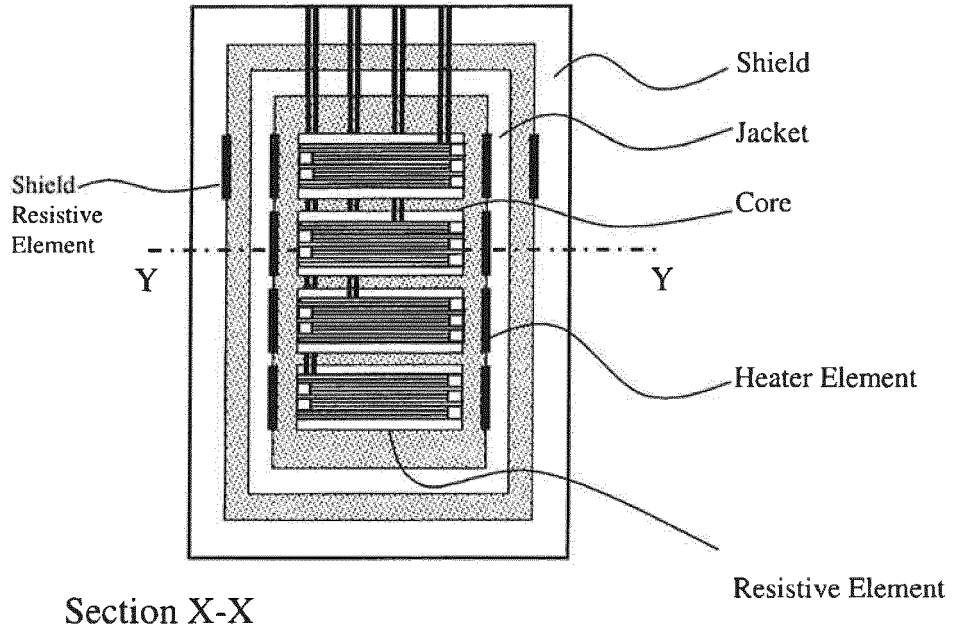

Figure 10



EUROPEAN SEARCH REPORT

Application Number
EP 18 16 8858

5

10

15

20

25

30

35

40

45

50

55

DOCUMENTS CONSIDERED TO BE RELEVANT			
Category	Citation of document with indication, where appropriate, of relevant passages	Relevant to claim	CLASSIFICATION OF THE APPLICATION (IPC)
X,P	RENAUD JAMES ET AL: "Development of a graphite probe calorimeter for absolute clinical dosimetry", MEDICAL PHYSICS, AIP, MELVILLE, NY, US, vol. 40, no. 2, 1 February 2013 (2013-02-01), pages 20701-20701, XP012170941, ISSN: 0094-2405, DOI: 10.1118/1.4773870 [retrieved on 2013-01-09] * figure 2a *	1-11	INV. G01T1/12 A61N5/00
X,P	DAURES J ET AL: "Paper;Small section graphite calorimeter (GR-10) at LNE-LNHB for measurements in small beams for IMRT;Small section graphite calorimeter (GR-10) at LNE-LNHB for measurements in small beams for IMRT", METROLOGIA, INSTITUTE OF PHYSICS PUBLISHING, BRISTOL, GB, vol. 49, no. 5, 10 August 2012 (2012-08-10), pages S174-S178, XP020229547, ISSN: 0026-1394, DOI: 10.1088/0026-1394/49/5/S174 * figure 3 *	1-15	TECHNICAL FIELDS SEARCHED (IPC) A61N G01T
X	US 3 790 794 A (MURRAY K ET AL) 5 February 1974 (1974-02-05) * columns 2-3; figure 1 *	1-11	
X	US 3 665 762 A (DOMEN STEVE R) 30 May 1972 (1972-05-30) * column 2, lines 42-63; claims 1,3; figure 2 *	1	
The present search report has been drawn up for all claims			
Place of search Munich		Date of completion of the search 23 November 2018	Examiner Gentil, Cédric
CATEGORY OF CITED DOCUMENTS X : particularly relevant if taken alone Y : particularly relevant if combined with another document of the same category A : technological background O : non-written disclosure P : intermediate document		T : theory or principle underlying the invention E : earlier patent document, but published on, or after the filing date D : document cited in the application L : document cited for other reasons & : member of the same patent family, corresponding document	

EPO FORM 1503 03.02 (P04C01)



EUROPEAN SEARCH REPORT

Application Number
EP 18 16 8858

5

10

15

20

25

30

35

40

45

50

55

DOCUMENTS CONSIDERED TO BE RELEVANT			
Category	Citation of document with indication, where appropriate, of relevant passages	Relevant to claim	CLASSIFICATION OF THE APPLICATION (IPC)
A	M R MCEWEN ET AL: "A portable calorimeter for measuring absorbed dose in the radiotherapy clinic", PHYSICS IN MEDICINE AND BIOLOGY, vol. 45, no. 12, 1 December 2000 (2000-12-01), pages 3675-3691, XP055245545, Bristol GB ISSN: 0031-9155, DOI: 10.1088/0031-9155/45/12/312 * page 3677, paragraphs 3,5-8 - page 3690 *	1-15	
A	----- US 2009/217999 A1 (BECKER PAUL [US]) 3 September 2009 (2009-09-03) * paragraph [0007]; figure 1 *	1-15	
A	----- US 2003/043879 A1 (TANAKA KEIICHI [JP] ET AL) 6 March 2003 (2003-03-06) * the whole document *	1-15	
A	----- WO 2007/128718 A1 (SCANDITRONIX WELLHOEFER AB [SE]; AHNESJOE ANDERS [SE]; EKLUND KARIN [S]) 15 November 2007 (2007-11-15) * the whole document *	1-15	
The present search report has been drawn up for all claims			TECHNICAL FIELDS SEARCHED (IPC)
Place of search Munich		Date of completion of the search 23 November 2018	Examiner Gentil, Cédric
CATEGORY OF CITED DOCUMENTS X : particularly relevant if taken alone Y : particularly relevant if combined with another document of the same category A : technological background O : non-written disclosure P : intermediate document		T : theory or principle underlying the invention E : earlier patent document, but published on, or after the filing date D : document cited in the application L : document cited for other reasons ----- & : member of the same patent family, corresponding document	

1
EPO FORM 1503 03.02 (P04C01)

ANNEX TO THE EUROPEAN SEARCH REPORT
ON EUROPEAN PATENT APPLICATION NO.

EP 18 16 8858

5 This annex lists the patent family members relating to the patent documents cited in the above-mentioned European search report.
The members are as contained in the European Patent Office EDP file on
The European Patent Office is in no way liable for these particulars which are merely given for the purpose of information.

23-11-2018

Patent document cited in search report	Publication date	Patent family member(s)	Publication date
US 3790794	A	05-02-1974	NONE
US 3665762	A	30-05-1972	NONE
US 2009217999	A1	03-09-2009	CA 2714620 A1 11-09-2009 EP 2245351 A2 03-11-2010 RU 2010139904 A 10-04-2012 US 2009217999 A1 03-09-2009 WO 2009111357 A2 11-09-2009
US 2003043879	A1	06-03-2003	JP 4646441 B2 09-03-2011 JP 2002357660 A 13-12-2002 US 2003043879 A1 06-03-2003
WO 2007128718	A1	15-11-2007	EP 2016444 A1 21-01-2009 US 2009090870 A1 09-04-2009 WO 2007128718 A1 15-11-2007

REFERENCES CITED IN THE DESCRIPTION

This list of references cited by the applicant is for the reader's convenience only. It does not form part of the European patent document. Even though great care has been taken in compiling the references, errors or omissions cannot be excluded and the EPO disclaims all liability in this regard.

Patent documents cited in the description

- US 61652540 B [0001]

Non-patent literature cited in the description

- **ROSS et al.** Water Calorimetry for Radiation Dosimetry. *Phys. Med. Biol.*, vol. 41, 1-29 [0008]
- Absorbed Dose Water Calorimeter. *Med. Phys.*, vol. 7, 157-159 [0008]
- **ALFONSO et al.** A New Formalism for Reference Dosimetry of Small and Non-Standard Fields. *Med. Phys.*, vol. 35, 5179-5186 [0010]
- **SEUNTJENS et al.** Photon Absorbed Dose Standards. *Metrologia*, vol. 46, S39-S58 [0040]
- **SEUNTJENS et al.** Review of Calorimeter-based Absorbed Dose to Water Standards. *IAEA Int. Symp. on Standards and Codes of Practice in Med. Rad. Dosimetry, IAEA-CN-96-3* [0041] [0047]
- The EGSnrc Code System: Monte Carlo Simulation of Electron and Photon Transport. **KAWRAKOW et al.** NRC Report PIRS-701. Canadian National Research Center, 2006 [0049]
- Gap Correction for the Calorimetric Measurement of Absorbed Dose in Graphite with a Co Beam. *Phys. Med. Biol.*, vol. 34, 1809-21 [0049]
- **OWEN et al.** Correction for the Effect of the Gaps around the Core of an Absorbed Dose Graphite Calorimeter in High Energy Photon Radiation. *Phys. Med. Biol.*, vol. 36, 1699-1704 [0049]
- Evaluation of Factors to Convert Absorbed Dose Calibrations in Graphite to Water for Mega-Voltage Photon Beams. **NUTBROWN et al.** NPL Report CIRM. UK National Physical Laboratory, 2000, vol. 37 [0049]
- **ALMOND et al.** AAPM TG-51 Protocol for Clinical Reference Dosimetry of High Energy Photon and Electron Beams. *Med. Phys.*, vol. 1 (26), 1847-1870 [0053]
- **SANDER et al.** NPL's New Absorbed Dose Standard for the Calibration of HDR192Ir Brachytherapy Sources. *Metrologia*, vol. 49, S184-S188.17 [0059]
- **ALBERTS et al.** CRC Handbook Of Chemistry and Physics. CRC, 1976 [0060]
- **PICARD et al.** Determination of the Specific Heat Capacity of a Graphite Sample using Absolute and Differential Methods. *Metrologia*, vol. 44, 294-302 [0060]
- The Physics of AAPM's TG-51 Protocol. **ROGERS.** Clinical Dosimetry Measurements in Radiotherapy, Medical Physics Monograph No. 34. Medical Physics Publishing, 239-298 [0061]
- **DUANE et al.** An Absorbed Dose Calorimeter for IM-RT Dosimetry. *Metrologia*, vol. 49, S168-S173 [0063]
- **DAURES et al.** New Constant-Temperature Operation Mode for Graphite Calorimeter at LNE-LNHB. *Phys. Med. Biol.*, vol. 50, 4035-4052 [0064]
- The Development of New Devices for Accurate Radiation Dose Measurement: A Guarded Liquid Ionization Chamber and an Electron Sealed Water Calorimeter. **STEWART.** Ph.D. Dissertation. McGill University, 2007 [0075]