

(No Model.)

H. A. WEBSTER.
BUFFING OR POLISHING APPLIANCE.

No. 573,735.

Patented Dec. 22, 1896.

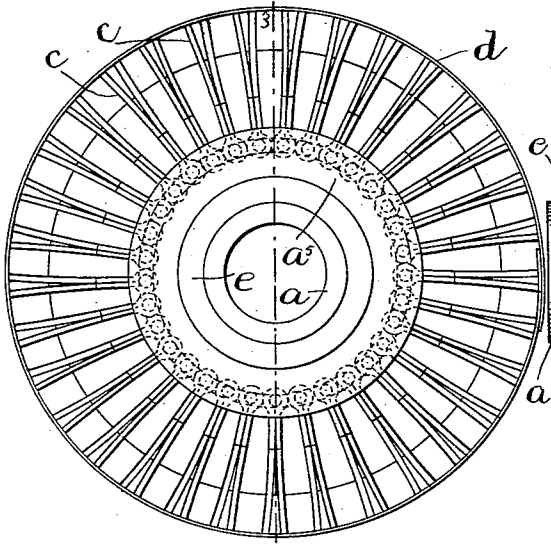

FIG. 1.

3

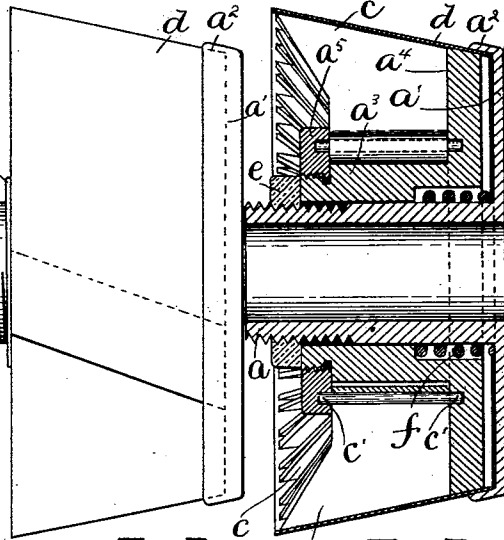

FIG. 2.

FIG. 3.

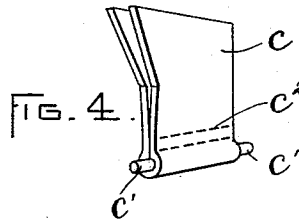

FIG. 4.

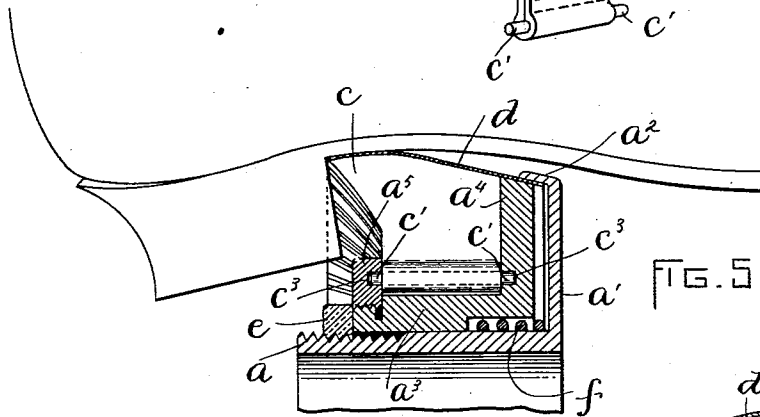

FIG. 5.

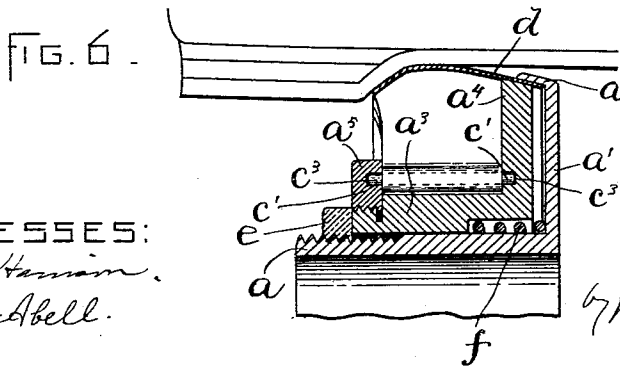

FIG. 6.

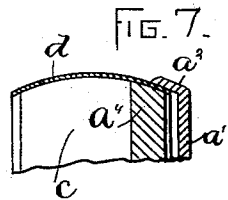

FIG. 7.

WITNESSES:
A. D. Hanson.
Rollin Abell.

INVENTOR:
H. A. Webster
By *Wm. B. Quincy*
Atty.

UNITED STATES PATENT OFFICE.

HAROLD A. WEBSTER, OF HAVERHILL, MASSACHUSETTS, ASSIGNOR TO
GEORGE H. P. FLAGG, TRUSTEE, OF BOSTON, MASSACHUSETTS.

BUFFING OR POLISHING APPLIANCE.

SPECIFICATION forming part of Letters Patent No. 573,735, dated December 22, 1896.

Application filed October 16, 1895. Serial No. 565,846. (No model.)

To all whom it may concern:

Be it known that I, HAROLD A. WEBSTER, of Haverhill, in the county of Essex and State of Massachusetts, have invented certain new and useful Improvements in Buffing or Polishing Appliances, of which the following is a specification.

This invention relates to rotary appliances for performing operations analogous to polishing or to buffing surfaces of articles presented to the appliance, the acting part of the appliance being a circular band or cover which surrounds a driving-shaft or rotary holder and is separated from said shaft or holder by a circular yielding cushion, so that the said band or cover constitutes a yielding periphery which is adapted to conform to various shapes and curvatures of the article presented to it.

The invention has for its object to provide an appliance of the character above mentioned in which the band or cover shall be unobstructed at one edge, so that the said edge is at all times flexible and is adapted to act on surfaces that would be inaccessible to a cover both ends or edges of which are positively secured to the holder.

The invention consists in the improvements which I will now proceed to describe and claim.

Of the accompanying drawings, forming a part of this specification, Figure 1 represents an end view of an appliance embodying my improvement. Fig. 2 represents a side view of the same. Fig. 3 represents a section on line 3 3 of Fig. 1. Fig. 4 represents a perspective view of one of the sections of the yielding cushion. Fig. 5 represents a view similar to a portion of Fig. 3, showing a boot or shoeshank presented to the free edge of the flexible cover. Fig. 6 represents a view similar to Fig. 5, showing the cushion and cover shaped or molded to act on the inclined breast of a spring-heel. Fig. 7 represents a view similar to a portion of Fig. 6, showing the cushion and cover in their natural form.

The same letters of reference indicate the same parts in all the figures.

In carrying out my invention I construct an appliance comprising a rotary holder adapted to be engaged with a driving-shaft, a circu-

lar yielding cushion surrounding said holder and composed of limp arms or flaps radiating from the holder, the ends of the cushion being formed by opposite edges of the flaps, a clamp at one end of said cushion and covering the inner end thereof, the edges of the strips forming the outer end of the cushion projecting unobstructedly outward from the holder, and a flexible working cover composed of a strip of material suitable for polishing or for buffing, said strip being engaged at its inner end with the clamp and being supported at its outer end by the unobstructed edges of the flaps, so that it can yield inwardly toward the holder or shaft to any desired extent without involving contact with said holder or shaft of the article or work presented to the said cover.

The holder comprises a tube or hub a , adapted to be placed upon a driving-shaft and engaged therewith by friction or otherwise, a clamping member consisting of a head or flange a' on one end of the hub a , said flange having an annular lip a^2 at its margin, and a collar a^3 , which loosely encircles the hub a and is movable lengthwise thereon, the said collar having at one end a flange or disk a^4 , the periphery of which forms a clamping member complementary to the lip a' , and a narrower flange a^5 at the opposite end of the collar a^3 .

The cushion comprises a series of flexible limp strips or flaps c , which may be composed of any suitable material, such as pieces of limp cloth or limp leather, the latter being preferred. Said strips are suitably attached to the holder in position to radiate therefrom, as shown in Fig. 1, their outer edges collectively forming a circular yielding support for the cover d , hereinafter described. I prefer to make each strip d by bending a single strip around a rod c' and connecting the flaps thus formed together at one side of the rod by stitches c^2 , as shown in Fig. 4, the ends of the rod projecting beyond the edges of the strip for entrance into recesses $c^3 c^3$, formed in the flanges $a^4 a^5$. The flange a^5 is adjustable, so that it can be moved toward and from the flange a^4 to secure and release the rods c' , the said flange a^5 being here shown as screwed onto the threaded end of the collar a^3 . The

edges of the strips that form the inner end of the cushion are covered or obstructed by the flange a^4 , but the edges that form the outer end of the cushion project unobstructedly outward from the narrower flange a^5 , and are therefore adapted to yield freely.

The cover d is composed of a strip or elongated sheet of suitable flexible material, which for polishing purposes is or may be of silesia or other suitable cloth, while for buffing purposes it may be of sandpaper or emery-cloth. The said cover is formed to encircle the cushion above described, and is of such width that one end may be inserted between the clamping members and there rigidly confined, the clamping members positively connecting it with the holder and causing it to rotate therewith. The other end of the cover d and the corresponding end of the cushion are unobstructed, so that they can yield inwardly toward the axis of the device, under the pressure of the work upon the cover, without permitting injurious contact between the work and any rigid part of the holder, the flange a^5 being of such size or diameter relatively to the diameter of the cushion that the latter projects outwardly a considerable distance from the holder and is supported only by the unobstructed edges of the flaps c , as shown in Figs. 1, 3, 5, and 6, so that the outer end of the cushion can yield toward the hub or holder to any extent that may be required.

The clamping members may be operated to release and grasp the cover by any suitable means. I have here shown as the adjusting means a nut e , engaged with the threaded outer end of the hub a and bearing against the corresponding end of the collar a^3 . When said nut is rotated in one direction, it causes a relative movement of the hub and collar, which brings the clamping members together, said members being suitably inclined, as shown in Figs. 3, 5, and 6, or otherwise formed so that upon the movement of the head a' toward the flange a^4 the clamping members will grasp the interposed portion of the cover. When the nut is turned in the opposite direction, the clamping members are allowed to separate from each other, a spring f being preferably employed to facilitate their separation.

In applying the cover the operator first separates the clamping members and then wraps the strip around the cushion, at the same time inserting one edge of the strip between the clamping members, the strip being of such length that one of its ends overlaps the other, as indicated in Fig. 2. The clamping members are then adjusted to grasp the strip, and the appliance is ready for operation.

The periphery of the cushion may have any desired form suited to the particular work required of it. In Figs. 2, 3, and 5 the outer edges of the strip c are inclined to give the periphery of the cushion the form of a cone-frustum, this form being particularly adapted to buffing the shank portions of boot and shoe

soles, the free edge of the cover being adapted by its form to enter the angle at the breast of the heel, as shown in Fig. 5.

In Fig. 6 I show the outer ends of the strip c as somewhat curved and the cover d molded so that in cross-section it has a concavo-convex form, its inner edge being thus adapted to the inclination of the clamping members, while its outer edge is adapted to the curvature of the tapering portion of the cushion, the cushion and cover thus formed being intended particularly for buffing the inclined breast of a spring-heel, as shown in Fig. 6. The cover, formed as shown in Fig. 6, may be removed when its outer portion is worn and reapplied with the portion that was previously between the clamping members placed upon the outer end of the cushion, thus considerably prolonging the usefulness of the cover.

It is obvious that the cushion and cover may be of any other suitable form, such as cylindrical.

I claim—

1. An appliance of the character specified, comprising a rotary holder; a series of limp flaps engaged at their inner edges therewith and radiating therefrom, and constituting a cushion; clamping members at one end of the holder covering the edges of the flaps which form one end of the cushion and backing up the same at that end, the edges of the flaps which form the other end of the cushion extending unobstructedly outward from the holder; and a working cover encircling the cushion and supported by the outermost edges thereof said cover being held at one end of the cushion by said clamping members while its opposite end is yieldingly supported by the unobstructed portions of the flaps.

2. An appliance of the character specified, comprising a rotary holder having outwardly-projecting flanges at its ends, one formed as a clamping member and of greater diameter than the other; a cushion composed of a series of limp arms or flaps confined at their inner sides between said flanges, the edges of the flaps which form the inner end of the cushion being covered or obstructed throughout their extent by the larger flange while the edges forming the outer end of the cushion project unobstructedly outward from the smaller flange and are adapted to yield inwardly; a movable clamping member adapted to cooperate with the first-mentioned clamping member; means for adjusting said movable member; and a working cover encircling the flaps and held at one end by the said clamping members, and yieldingly supported at the other end by the unobstructed outer ends of the flaps.

3. An appliance of the character specified, comprising a rotary hub having a flange formed as a clamping member; a collar or sleeve loosely mounted on said hub, and having at one end a flange formed as a clamping member to cooperate with the flange on the

hub and at the other end an adjustable flange
of less diameter, said flanges on the sleeve
having recesses in their confronting sides; a
cushion composed of a series of limp arms or
5 flaps confined between the flanges of the
sleeve, the edges of the flaps which form
the inner end of the cushion being covered
by the larger flange, while the edges which
form the outer end of the cushion project un-
10 obstructedly outward from the smaller flange,
and are adapted to yield; rods engaged with
the flaps and with the recesses in the sleeve-
flanges; a working cover encircling the flaps
and held at one end by the clamping mem-

bers, its other end being yieldingly sup- 15
ported by the unobstructed ends of the flaps;
and a clamp-adjusting nut engaged with the
hub and bearing against one end of the
sleeve, substantially as and for the purpose
described. 20

In testimony whereof I have signed my
name to this specification, in the presence of
two subscribing witnesses, this 9th day of
October, A. D. 1895.

HAROLD A. WEBSTER.

Witnesses:

C. F. BROWN,
A. D. HARRISON.