



(51) International Patent Classification:

A63B 71/00 (2006.01) A45F 5/00 (2006.01)  
A41D 20/00 (2006.01) A47G 1/02 (2006.01)  
A45C 15/04 (2006.01) A63B 71/06 (2006.01)  
A45D 42/06 (2006.01) F16M 13/04 (2006.01)  
A45D 42/16 (2006.01) G02B 5/10 (2006.01)

(21) International Application Number:

PCT/CA2017/000229

(22) International Filing Date:

17 October 2017 (17.10.2017)

(25) Filing Language:

English

(26) Publication Language:

English

(30) Priority Data:

2,946,435 19 October 2016 (19.10.2016) CA  
2,949,693 23 November 2016 (23.11.2016) CA

(71) Applicant: DMYK INVENTIONS INC. [CA/CA]; 3142  
137A Street, Surrey, British Columbia V4P 2B7 (CA).

(72) Inventor: MAHARAJ, Damien; 3142 137A Street, Sur-  
reyy, British Columbia V4P 2B7 (CA).

(74) Agent: URBANEK, Ted, B.; Urbanek Intellectual Property  
Law, 2300 - 1066 West Hastings Street, Vancouver, British  
Columbia V6E 3X2 (CA).

(81) Designated States (unless otherwise indicated, for every  
kind of national protection available): AE, AG, AL, AM,  
AO, AT, AU, AZ, BA, BB, BG, BH, BN, BR, BW, BY, BZ,  
CA, CH, CL, CN, CO, CR, CU, CZ, DE, DJ, DK, DM, DO,  
DZ, EC, EE, EG, ES, FI, GB, GD, GE, GH, GM, GT, HN,  
HR, HU, ID, IL, IN, IR, IS, JO, JP, KE, KG, KH, KN, KP,  
KR, KW, KZ, LA, LC, LK, LR, LS, LU, LY, MA, MD, ME,  
MG, MK, MN, MW, MX, MY, MZ, NA, NG, NI, NO, NZ,  
OM, PA, PE, PG, PH, PL, PT, QA, RO, RS, RU, RW, SA,  
SC, SD, SE, SG, SK, SL, SM, ST, SV, SY, TH, TJ, TM, TN,  
TR, TT, TZ, UA, UG, US, UZ, VC, VN, ZA, ZM, ZW.

(54) Title: AWARENESS DEVICE FOR ATHLETES

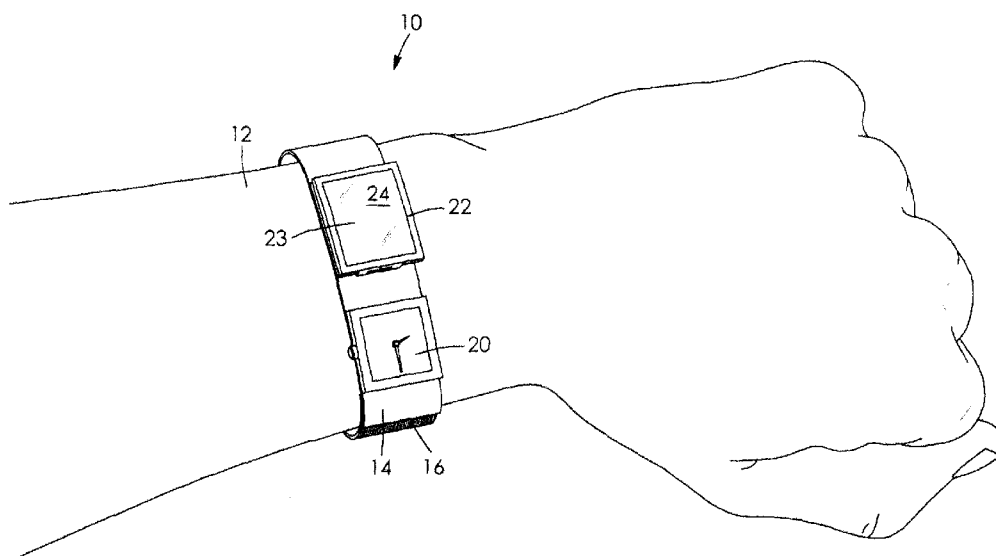


FIG. 1

(57) Abstract: A personal safety device is provided, the device comprising: i) a mirror holder, the mirror holder defining an interior and including: a bottom; a top which is opposite the bottom; a convex mirrored surface on the top; a rim which retains the mirrored surface; a back; a front which is opposite the back; a first side; a second side which is opposite the first side; a hinge between the top and the back; a releasable mating pair, a first half which is on the front and a second half which is on the rim, such that the top functions as a lid for releasably covering the interior; and ii) a wrist strap, the wrist strap retaining the mirror holder. A combination including a watch or a monitor and the mirror holder is also provided.



**(84) Designated States** (*unless otherwise indicated, for every kind of regional protection available*): ARIPO (BW, GH, GM, KE, LR, LS, MW, MZ, NA, RW, SD, SL, ST, SZ, TZ, UG, ZM, ZW), Eurasian (AM, AZ, BY, KG, KZ, RU, TJ, TM), European (AL, AT, BE, BG, CH, CY, CZ, DE, DK, EE, ES, FI, FR, GB, GR, HR, HU, IE, IS, IT, LT, LU, LV, MC, MK, MT, NL, NO, PL, PT, RO, RS, SE, SI, SK, SM, TR), OAPI (BF, BJ, CF, CG, CI, CM, GA, GN, GQ, GW, KM, ML, MR, NE, SN, TD, TG).

**Published:**

— *with international search report (Art. 21(3))*

## AWARENESS DEVICE FOR ATHLETES

### CROSS REFERENCE TO RELATED APPLICATIONS

This application claims benefit of Canadian Application Serial No. 2946435, filed on October 19, 2016 entitled AWARENESS DEVICE FOR ATHLETES, the contents of which are incorporated herein by reference.

### FIELD

The present technology relates to an easy to wear device to be used by runners and walkers so that they can observe activity behind them while being aware of their own physical state. More specifically, the device is a watch, a rear view mirror and a storage compartment for identification and medication.

### BACKGROUND

There are many situations where a user needs to know what is occurring behind their back. Runners, walkers and cyclist all need to look forward as much as possible. Looking over one's shoulder can lead to accidents including tripping and falling or running in to objects. However, there are many situations where one wants to be able to check over their shoulder.

Increasingly, active people are being encouraged to carry identification and any medication that they might need. This is especially important for people with allergies, heart conditions, and other conditions that require medication. Older runners are encouraged to carry aspirin.

Many athletes wear monitors that provide health information. Some include a watch and timer, but they are essentially dedicated devices with few additional capabilities.

FR 2,599,521 relates to a watch provided with a mirror mounted pivotally on a watch and covering the display. It is made up by incorporating and combining a moving or static reflecting element on a wrist watch or the like supplemented with a lens on the strap itself. It is intended to enable a person to survey his surroundings outside the visual field without having to turn around, without having to move his body or his head and this for preventive, utilitarian as well

as recreational purposes. As shown, the mirror is concave and thus would not provide a good rear view. The mirror in the resulting device must be articulated in order that the user can read the time, or view any other metric on their watch or monitor. No further functionality is provided, hence a user will have to carry identification and/or medication elsewhere on them.

United States Patent Application 20050030836 discloses a watch that has a mirror dial plate assembly comprising a light valve layer, and a light reflective layer. The light valve is controlled by an electronic circuit for its on, off, and variable light transmission. The reflectivity of the mirror assembly is thus controlled. Dial marks are incorporated either on or in the light valve layer, or using a separation transparent layer. This would not provide a clear enough image for a user to see what is occurring behind them, nor could it be used to retrofit a watch or monitor to increase functionality.

United States Patent 7,063,427 discloses a portable mirror device for hunters or other persons who need to extend their field of view to the side or rear without moving their head appreciably. The device is reversibly attached to a body-segment of the user and can either be raised to an active position or folded in a stored position against the body-segment. Also disclosed is an attachment-cuff for attaching the invention to the body-segment. The cuff comprises a rigid or semi-rigid inner member encased by a covering, which covering has two ends with closure means attached thereto for securing the cuff to the body-segment. This would not be suitable for a runner or other athlete to use while running, cycling or being involved in other athletic activities.

United States Patent Application 20140226225 discloses a rear view mirror device for use by the rider of a bicycle or other personal mobility vehicle comprising a convex reflective mirror integrated with a base component and held in place over the optimum sweet spot triangulated area between the index finger, thumb and wrist of a bare hand or a gloved hand of any size by means of a harness system comprising an elastic cord threaded through holes in the base component to form loops for insertion of the wrist, index finger and thumb of the hand and secured on the back of the hand through cord pulls at the ends of the elastic cord. The device provides a near vibration-less, clear, sharp and accurate rear viewing, and effortless, infinite maneuverability into the most optimal position to focus through an individual's own unique

eyesight, leading to less eye strain. This device interferes with a user's hand, and has only one function. It would not be suitable for use with a watch or monitor.

United States Patent 3,717,403 discloses a rear-viewing mirror that is adapted to be worn by the viewer. The mirror includes a base; a frame mounted on the base; and a mirror mounted in the frame. Apparel means, for example, a glove, or a mitt, or a band, or an elastic band, is secured to the base and is adapted to be worn by the user. This wearing is carried out in such a manner that the mirror is visible to the wearer. This device has only one function and would not be suitable for a runner.

United States Patent 4,054,375 discloses a rear view cycling mirror comprising a case housing a mirror adapted to be strapped to the wrist of a cyclist or attached via a clip to the bicycle. The mirror is mounted on the inside face of the case cover which is hinged to the base of the case by a universal ball joint. This joint provides maximum adjustability to the cyclist. The strap or clip is inserted through a slot in a dropped portion of the base. This device has only one function and would not be suitable for a runner.

United States Patent 4,490,012 discloses a safety rear view mirror device that has a detachable mounting base part for removably securing it alternately on the brim or peak portion of a cap or the crown portion of a hat or other type of head covering. The mounting base part is bifurcated to alternately fit over and to be securely clamped by a mounting screw to the peak portion of a cap or alternatively, to rest against and to be clamped on the crown portion of a hat by a through-extending mounting screw. A flexible and ductile connector cable is endwise slidably, removably mounted at one end within a collar portion of the base part and, at its other end, is adapted to be securely and detachably mounting by a spring clip to a back mounting for a back-viewing mirror. The cable is constructed for easy finger-grip bending to move the mirror into the best rear viewing position, with full assurance that the cable will stay in its selected bent positioning. The cable has a metal core cast within and enclosed by a hollow insulating sheath. Head or hat mounted mirrors have been found to provide a poor image and are difficult to use as they obstruct the user's vision, if positioned to provide a rear view.

United States Patent 5,361,169 discloses a mirror which is attached to an underwater diver's wrist or arm. By placing the mirror in front of his face mask and controlling the line of sight reflected by the mirror, the diver can inspect equipment on his body or easily access equipment with the hand not wearing the mirror. In addition, the diver's peripheral vision is improved so he or she can see objects, fish or a diving partner located behind them. The mirror is attached to the diver's wrist or arm by a wrist strap made of water resistant material such as nylon or rubber. Alternate embodiments include a pouch containing the mirror on a flexible strap and a diver's handheld console with a hinged plate containing the mirror. This device is specific to diving and would not be suitable for runners or other athletes to use to check what is happening behind them. It is limited in functionality.

In a related technology, United States Patent 4,636,047 discloses a high quality mirror readily at hand for the emergency use of a contact lens wearer, an accessory mirror comprising a thin wafer having a mirrored outer surface is affixed to the back of a wrist watch. The presently preferred embodiment of the invention comprises a steel wafer shaped approximately to conform with the shape of the watch back. The steel wafer has a first surface which is mirror finished and chromium plated and a second surface coated with an adhesive layer which is itself overlaid by a paper wafer. Thus, the paper wafer is removable to permit affixing the steel wafer to the wrist watch back. A process for preparing the preferred embodiment of the product is disclosed. In addition, variants utilizing a plastic film sold under the trademark "Mylar" and coated with metal and incorporating a protective cover for the mirror surface are also disclosed. This would not be suitable for an athlete to use for viewing behind them, nor does it provide a storage area.

What is needed is a device that is multipurpose to allow an active person to easily see behind themselves on an as need basis, that does not obstruct their forward vision. The device would preferably be for locating on a user's wrist and would be retained with a removable strap upon which a convex mirror is mounted. The device would also include a monitor such as a heart rate monitor, a Global Positioning System (GPS), a fitness tracker and the like, or watch, also mounted on the strap. The device would further include a storage compartment on an under side of the

mirror for holding identification, money, medication and the like. The device would be small and unobtrusive.

#### SUMMARY

The present technology is a multipurpose device for active people that allows them to see behind themselves on an as need basis, that does not obstruct their forward vision. The device is for locating on a user's wrist and includes a removable strap for retaining a convex mirror and a monitor such as a heart rate monitor, a Global Navigation Satellite System (GNSS), a fitness tracker and the like, or watch. The device further includes a storage compartment on an under side of the mirror for holding identification, money, medication, a key and the like. The device is small and unobtrusive and can replace the user's watch, monitor, fitness tracker or the like.

In one embodiment, a personal safety device for releasable attachment to a user's wrist is provided, the device comprising: i) a mirror holder, the mirror holder defining an interior and including: a bottom; a top which is opposite the bottom; a convex mirrored surface on the top; a rim which retains the mirrored surface; a back; a front which is opposite the back; a first side; a second side which is opposite the first side; a hinge between the top and the back; a releasable mating pair, a first half which is on the front and a second half which is on a front of the rim, such that the top functions as a lid for releasably covering the interior; and ii) a wrist strap, the wrist strap retaining the mirror holder.

In the personal safety device, the releasable mating pair may be a detent pair.

In the personal safety device the mirror holder may be rectangular and may have a longitudinal axis coaxial with a length of the wrist strap.

In the personal safety device, the mirror holder may have a width no wider than a width of the wrist strap.

In the personal safety device, the hinge may be a living hinge.

In the personal safety device, the interior may be about 3 cm long.

The personal safety device may further comprise a removable cover that is slidably engaged with the rim.

In the personal safety device, the rim may include a pair of grooves, one in a first inner side and the other in a second inner side, and a slot proximate the back, the pair of grooves and the slot slidably retaining the removable cover.

In the personal safety device the removable cover may include a stop that retains the removable cover in the rim.

The personal safety device may include a piece of personal identification housed in the interior.

The personal safety device may include a medication housed in the interior.

In another embodiment, an awareness device for releasable attachment to a user's wrist is provided, the device comprising: : i) a mirror holder, the mirror holder defining an interior and including: a bottom; a top which is opposite the bottom; a convex mirrored surface on the top; a rim which retains the mirrored surface; a back; a front which is opposite the back; a first side; a second side which is opposite the first side; a hinge between the top and the back; a releasable mating pair, a first half which is on the front and a second half which is on the rim, such that the top functions as a lid for releasably covering the interior; ii) a monitor, a watch or a combination watch-monitor; and iii) a wrist strap, the wrist strap retaining the mirror holder and the monitor, the mirror and the monitor mounted a long a length of the wrist strap.

In the awareness device, the mirror holder may be rectangular and may have a longitudinal axis coaxial with the length of the wrist strap.

In the awareness device, the mirror holder may have a width no wider than a width of the band.

In the awareness device, the interior may be about 3 cm long.

The awareness device may further comprise a removable cover that is slidably engaged with the rim.

In the awareness device, the rim may include a pair of grooves, one in a first inner side and the other in a second inner side, and a slot proximate the back, the pair of grooves and the slot slidably retaining the removable cover.

In the awareness device the removable cover may include a stop that retains the removable cover in the rim.

In the awareness device, the hinge may include a pair of knuckles and a pin therethrough.

In the awareness device, the bottom may be a curved bottom.

In the awareness device, the mirror holder and the monitor, watch or combination watch-monitor may be permanently mounted on the wrist strap or may be integral with the wrist strap.

In the awareness device, the monitor may be selected from the group consisting of a heart rate monitor, a Global Navigation Satellite System (GNSS), and a fitness tracker.

The awareness device may comprise the combination watch-monitor.

In yet another embodiment, a method of improving personal safety of a user is provided, the method comprising: the user attaching a personal safety device on their wrist, the personal safety device comprising: i) a mirror holder, the mirror holder defining an interior and including: a bottom; a top which is opposite the bottom; a convex mirrored surface on the top; a rim which retains the mirrored surface; a back; a front which is opposite the back; a first side; a second side which is opposite the first side; a hinge between the top and the back; a releasable mating pair, a first half which is on the front and a second half which is on the rim, such that the top functions as a lid for releasably covering the interior; and ii) a wrist strap, the wrist strap retaining the mirror holder; and the user lifting their wrist to a height to permit viewing of an area behind themselves.

The method may further comprise the user storing a piece of personal identification in the interior of the mirror holder.

The method may further comprise the user storing a medication in the interior of the mirror holder.

In yet another embodiment, a rear view mirror for attachment to a wrist band is provided, the rear view mirror comprising a mirror holder, the mirror holder defining an interior storage space and including: a bottom; a top which is opposite the bottom; a convex mirrored surface on the top; a rim which retains the mirrored surface; a back; a front which is opposite the back; a first side; a second side which is opposite the first side; a hinge between the top and the back; a detent pair, a first half which is on the front and a second half which is on the rim, such that the top functions as a lid for releasably covering the interior storage space; and ii) at least one strap including a closure, the strap for retaining the mirror holder on the wrist band.

In the rear view mirror, the mirror holder may further comprise a removable cover that is slidably engaged with the rim.

In the rear view mirror, the rim may include a pair of grooves, one in a first inner side and the other in a second inner side, and a slot proximate the back, the pair of grooves and the slot slidably retaining a removable cover.

In the rear view mirror, the removable cover may include a stop that retains the removable cover in the rim.

In the rear view mirror, the top may be entirely mirrored.

## FIGURES

Figure 1 is a plan view of the device of the present technology on a user's wrist.

Figure 2 is a partially exploded view of the device of Figure 1.

Figure 3 is a perspective view of the mirror holder of Figure 1.

Figure 4 is a longitudinal sectional view of the mirror holder of Figure 3.

Figure 5 is an exploded view of the hinge of an alternative embodiment of Figure 1.

Figure 6A is a plan view of an alternative embodiment of Figure 1; Figure 6B is a sectional view taken through line 6B in Figure 6A; and Figure 6C is a sectional view taken through line 6C in Figure 6A.

Figure 7 is a sectional view of an alternative embodiment of Figures 6A-C, taken along the same line in Figure 6A as 6B.

Figure 8A is top view of an alternative embodiment; Figure 8B is a side view of the alternative embodiment in the retracted position.

Figure 9A a side view of an alternative embodiment; Figure 9B is a medial longitudinal sectional view of an alternative embodiment; Figure 9C is an end view of an alternative embodiment.

Figure 10 is a top view of the device.

Figure 11 is and end view of the top of the device.

#### DESCRIPTION

Except as otherwise expressly provided, the following rules of interpretation apply to this specification (written description, claims and drawings): (a) all words used herein shall be construed to be of such gender or number (singular or plural) as the circumstances require; (b) the singular terms "a", "an", and "the", as used in the specification and the appended claims include plural references unless the context clearly dictates otherwise; (c) the antecedent term "about" applied to a recited range or value denotes an approximation within the deviation in the range or value known or expected in the art from the measurements method; (d) the words "herein", "hereby", "hereof", "hereto", "hereinbefore", and "hereinafter", and words of similar import, refer to this specification in its entirety and not to any particular paragraph, claim or other subdivision, unless otherwise specified; (e) descriptive headings are for convenience only and shall not control or affect the meaning or construction of any part of the specification; and (f) "or" and "any" are not exclusive and "include" and "including" are not limiting. Further, the terms "comprising," "having," "including," and "containing" are to be construed as open ended terms (i.e., meaning "including, but not limited to,") unless otherwise noted.

To the extent necessary to provide descriptive support, the subject matter and/or text of the appended claims is incorporated herein by reference in their entirety.

Recitation of ranges of values herein are merely intended to serve as a shorthand method of referring individually to each separate value falling within the range, unless otherwise indicated herein, and each separate value is incorporated into the specification as if it were individually recited herein. Where a specific range of values is provided, it is understood that each intervening value, to the tenth of the unit of the lower limit unless the context clearly dictates otherwise, between the upper and lower limit of that range and any other stated or intervening value in that stated range, is included therein. All smaller sub ranges are also included. The upper and lower limits of these smaller ranges are also included therein, subject to any specifically excluded limit in the stated range.

Unless defined otherwise, all technical and scientific terms used herein have the same meaning as commonly understood by one of ordinary skill in the relevant art. Although any methods and materials similar or equivalent to those described herein can also be used, the acceptable methods and materials are now described.

#### DEFINITIONS

Detent pair – in the context of the present technology, a detent pair is a mechanism that temporarily keeps one part in a certain position relative to that of another, and can be released by applying force to one of the parts.

#### DETAILED DESCRIPTION

A multipurpose device, generally referred to as 10 is shown in Figure 1, on the wrist 12 of a user. The user is typically an athlete, but need not be. The device 10 has a wrist band 14 that releasably holds the device 10 around the user's wrist 12. It has a closure 16 which may have a buckle closure or a hook and loop type closure. A monitor, watch or combination watch-monitor 20 is retained on the wrist band 14 and proximate the monitor, watch or combination watch-monitor 20 is a mirror holder 22. The mirror holder 22 has a top 23 that includes an upper mirrored

surface 24, which is convex. In some embodiments, the rim 42 supports or retains the mirrored surface 24 but does not bound the mirrored surface 24, in other words, the entire top 23 is mirrored.

As shown in Figure 2, the mirror holder 22 is rectangular and has a longitudinal axis 26 coaxial with the length 28 of the wrist band 14. The holder 22 has a width 30 that is preferably no wider or not significantly wider than the width 32 of the band 14, in other words, no wider than the monitor 20. In one embodiment, the mirror holder is releasably retained on the wrist band 14 with one or more straps 34. Preferably the straps 34 have a hook and loop type closure 36.

In another embodiment, the straps are one piece and are stretchable. This allows for different wrist band widths and thicknesses to be accommodated.

As shown in Figure 3, the mirror holder 22 has a bottom 40, the top 23, a rim 42, a back 44, a front 46, a first side 48 and a second side 50, which is parallel and opposite the first side 48. A living hinge 50 is continuous with the rim 42 of the top 23 and the back 44, allowing the top 23, with its rim 42 and mirrored surface 24 to function as a lid, generally referred to as 52. A front end 60 of the lid 52 and the front 46 each have a mating member 62, 64 to releasably close the lid 52. In the preferred embodiment, the mating members 62, 64 are a detent pair. The lid 52 covers an aperture 66. The front 46 and back 44, the sides 48, 50, the bottom 40, and the top 23 define an interior 68 that is continuous with the aperture 66.

As shown in Figure 4, the interior 68 provides a storage space for identification 70, a small noisemaker 71, medication 72 and/or a small key 74. It is preferably about 2.5 to about 3 or about 3.5 cm long and all lengths therebetween. The mirror holder 22 preferably has a slightly curved bottom 40, or a relatively flat bottom with a curve at one end 76. The slight curve 76 or the curve at one end allows the device to fit the user's wrist better than a flat bottom 40 would.

The mirror holder 22 is preferably a plastic polymeric material with a mirrored upper surface. Suitable plastics include polystyrene, polycarbonate, and other non-malleable plastic polymers.

In an alternative embodiment shown in Figure 5, the hinge 80 is a two part hinge with a pin 82 extending through the knuckles 84 of the top 23 and the back 44. The mirror holder 22 is permanently affixed to the wrist band 14 or is integral with the wrist band 14.

In yet another embodiment shown in Figure 6A, the mirrored surface 24 has a removable cover 90. In this embodiment, the rim both retains and bounds the mirrored surface. The cover is a thin sheet of a pliable plastic polymer that runs on a pair of slides in the rim 42. There is one slide 94 on an inner surface 102 of the first side 96 of the rim 42 (Figure 6B) and a second slide 98 on an inner surface 102 of the second side 100 of the rim 42 (Figure 6C). The slides 92 in the preferred embodiment are simply grooves in the rim 42. A slot 104 in the rim 42 allows the removable cover 90 to be drawn away from the mirrored surface 24. A stop 106 on the removable cover 90 stops the removable cover 90 from sliding off the mirror holder 22. The cover 90 allows a user to cover the mirrored surface 24 when in locations where the mirrored surface 24 could cause alarm.

In yet another embodiment shown in Figure 7, the mirror holder 22 has an articulating cover 120. In this embodiment, the rim both retains and bounds the mirrored surface. The articulating cover is made of a series of bands 122 with a linkage 124 between each band 122. The articulating cover 120 slides in one slide 94 on an inner surface 102 of the first side 96 of the rim 42 (Figure 6A and 6B) and a second slide 98 on an inner surface 102 of the second side 100 of the rim 42 (Figure 6C). The slides 92 in the preferred embodiment are simply grooves in the rim 42. A slot 104 in the rim 42 allows the removable cover 90 to be drawn away from the mirrored surface 24. Returning to Figure 7, a groove 126 in the bottom 40 houses the articulating cover 120 when it is withdrawn from the mirrored surface 24. A stop 128 on the articulating cover 120 stops the cover 120 from sliding off the mirror holder 22.

In yet another embodiment, shown in Figure 8A, the cover is an accordion cover 150. In this embodiment, the rim both retains and bounds the mirrored surface. The cover 150 is scored normal to the longitudinal axis 26, such that there is a plurality of score lines 152. As shown in Figure 8B, when pressure is exerted on the cover 150, it folds along the score lines 152, exposing

the mirrored surface 24. There may be one cover 150 for the mirror holder 22 or there may be two, with one retracting to towards the front 46 and the other retracting towards the back 44.

As shown in Figure 2, the straps 34 may be affixed to the bottom 40 of the mirror holder 22 or may be, as shown in Figure 9A, fed through slots 200 proximate the bottom 40 of the mirror holder 22. Alternatively, as shown in Figure 9B, or additionally, a longitudinal slot 226 may run through the bottom 40 along the length 228 of the bottom 40. This slot may be closed or may be open as shown in Figure 9C. In these embodiments, the slot is sized to fit the wrist band of the watch or monitor. One specific example is a Fitbit® Surge which is 1.34" (34.3 mm) wide, the Fitbit Charge which is .8" (20.3 mm) wide, the Fitbit Alta which is .6" (15.2 mm) wide, the Fitbit Blaze which is .87" (22.1 mm), the Fitbit Flex which is 0.5" (12.7 mm) wide and the Fitbit One which is .76" (19.3 mm) wide. This may be through the inclusion of spacers that fill the void in a slot sized to accept the Fitbit Charge when used with the Alta, One or Flex or a slot sized to fit the Blaze when used with the Charge or the One or a slot sized to fit the Surge when used with any other Fitbit. Alternatively, the slot may be specific to the product. The open slot provides for more flexibility in sizing.

With regard to a large sized wristband, the device bottom 40 would preferably have a curvature with a radius of about 45 to about 47 mm at least over about 20 mm from the front 46 of the device, with the remaining about 10 to 15 mm being substantially flat. Alternatively, the entire bottom 40 of the device may be curved with a radius of about 45 to about 47 mm. The total length of the device would preferably be about 30 to about 35 mm. The mirror may be about 25 mm long and may cover the entire upper surface without having a frame about it. The radius of curvature of the mirror is about 890 mm and 1800 mm.

The device 10 may have "ID" 248 formed into a top surface as shown in Figure 10. This would alert someone to the fact that identification and potentially relevant health information is held inside. As shown in Figure 11, the identification 70 may be retained on the underside 250 of top 23 with C-shaped slides 252 on either side of the underside 250.

While example embodiments have been described in connection with what is presently considered to be an example of a possible most practical and/or suitable embodiment, it is to be

understood that the descriptions are not to be limited to the disclosed embodiments, but on the contrary, is intended to cover various modifications and equivalent arrangements included within the spirit and scope of the example embodiment. Those skilled in the art will recognize, or be able to ascertain using no more than routine experimentation, many equivalents to the specific example embodiments specifically described herein. Such equivalents are intended to be encompassed in the scope of the claims, if appended hereto or subsequently filed.

## CLAIMS

1. A personal safety device for releasable attachment to a user's wrist, the device comprising: i) a mirror holder, the mirror holder defining an interior and including: a bottom; a top which is opposite the bottom; a convex mirrored surface on the top; a rim which retains the mirrored surface; a back; a front which is opposite the back; a first side; a second side which is opposite the first side; a hinge between the top and the back; a releasable mating pair, a first half which is on the front and a second half which is on a front of the rim, such that the top functions as a lid for releasably covering the interior; and ii) a wrist strap, the wrist strap retaining the mirror holder.
2. The personal safety device of claim 1, wherein the releasable mating pair is a detent pair.
3. The personal safety device of claim 1 or 2, wherein the mirror holder is rectangular and has a longitudinal axis coaxial with a length of the wrist strap.
4. The personal safety device of any one of claims 1 to 3, wherein the hinge is a living hinge.
5. The personal safety device of any one of claims 1 to 4, wherein the top is entirely mirrored.
6. The personal safety device of any one of claims 1 to 4, further comprising a removable cover that is slidably engaged with the rim.
7. The personal safety device of claim 6, wherein the rim includes a pair of grooves, one in a first inner side and the other in a second inner side, and a slot proximate the back, the pair of grooves and the slot slidably retaining the removable cover.
8. The personal safety device of claim 7, wherein the removable cover includes a stop that retains the removable cover in the rim.

9. An awareness device for releasable attachment to a user's wrist, the device comprising: : i) a mirror holder, the mirror holder defining an interior and including: a bottom; a top which is opposite the bottom; a convex mirrored surface on the top; a rim which retains the mirrored surface; a back; a front which is opposite the back; a first side; a second side which is opposite the first side; a hinge between the top and the back; a releasable mating pair, a first half which is on the front and a second half which is on the rim, such that the top functions as a lid for releasably covering the interior; ii) a monitor, a watch or a combination watch-monitor; and iii) a wrist strap, the wrist strap retaining the mirror holder and the monitor, the mirror and the monitor mounted a long a length of the wrist strap.
10. The awareness device of claim 9, wherein the mirror holder is rectangular and has a longitudinal axis coaxial with the length of the wrist strap.
11. The awareness device of claim 9 or 10, wherein the top is entirely mirrored.
12. The awareness device of claim 9 or 10, wherein the mirror holder further comprises a removable cover that is slidably engaged with the rim.
13. The awareness device of claim 12, wherein the rim includes a pair of grooves, one in a first inner side and the other in a second inner side, and a slot proximate the back, the pair of grooves and the slot slidably retaining the removable cover.
14. The awareness device of claim 11, wherein the removable cover includes a stop that retains the removable cover in the rim.
15. The awareness device of any one of claims 9 to 14, wherein the hinge may include a pair of knuckles and a pin therethrough.
16. The awareness device of any one of claims 9 to 15, wherein the mirror holder and the monitor, watch or combination watch-monitor are permanently mounted or are integral with the wrist strap.

17. The awareness device of any one of claims 9 to 16, wherein the monitor is selected from the group consisting of a heart rate monitor, a Global Navigation Satellite System (GNSS), and a fitness tracker.

18. A method of improving personal safety of a user, the method comprising: the user attaching a personal safety device on their wrist, the personal safety device comprising: i) a mirror holder, the mirror holder defining an interior and including: a bottom; a top which is opposite the bottom; a convex mirrored surface on the top; a rim which retains the mirrored surface; a back; a front which is opposite the back; a first side; a second side which is opposite the first side; a hinge between the top and the back; a releasable mating pair, a first half which is on the front and a second half which is on the rim, such that the top functions as a lid for releasably covering the interior; and ii) a wrist strap, the wrist strap retaining the mirror holder; and the user lifting their wrist to a height to permit viewing of an area behind themselves.

19. The method of claim 18, further comprising the user storing a piece of personal identification in the interior of the mirror holder.

20. The method of claim 18 or 19, further comprising the user storing a noise maker in the interior of the mirror holder.

21. The method of any one of claims 18 to 20, further comprising the user storing a medication in the interior of the mirror holder.

22. A rear view mirror for attachment to a wrist band, the rear view mirror comprising a mirror holder, the mirror holder defining an interior storage space and including: a bottom; a top which is opposite the bottom; a convex mirrored surface on the top; a rim which retains the mirrored surface; a back; a front which is opposite the back; a first side; a second side which is opposite the first side; a hinge between the top and the back; a detent pair, a first half which is on the front and a second half which is on the rim, such that the top functions as a lid for releasably covering the interior storage space; and ii) at

least one strap including a closure, the strap for retaining the mirror holder on the wrist band.

23. The rear view mirror of claim 22, wherein the mirror holder further comprises a removable cover that is slidably engaged with the rim.

24. The rear view mirror of claim 23, wherein the rim includes a pair of grooves, one in a first inner side and the other in a second inner side, and a slot proximate the back, the pair of grooves and the slot slidably retaining a removable cover.

25. The rear view mirror of claim 23 or 24, wherein the removable cover includes a stop that retains the removable cover in the rim.

26. The rear view mirror of claim 22, wherein the top is entirely mirrored.

1/9

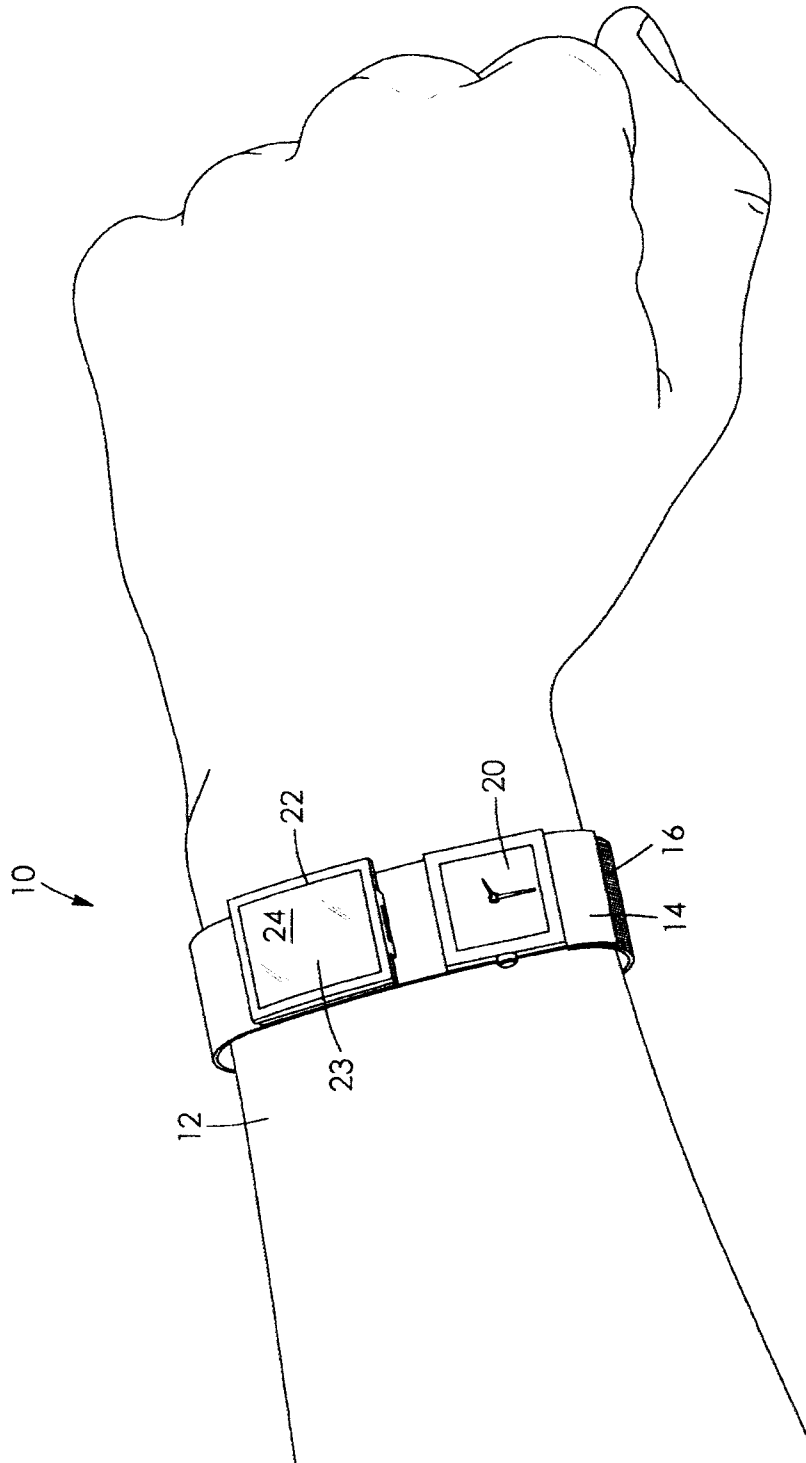
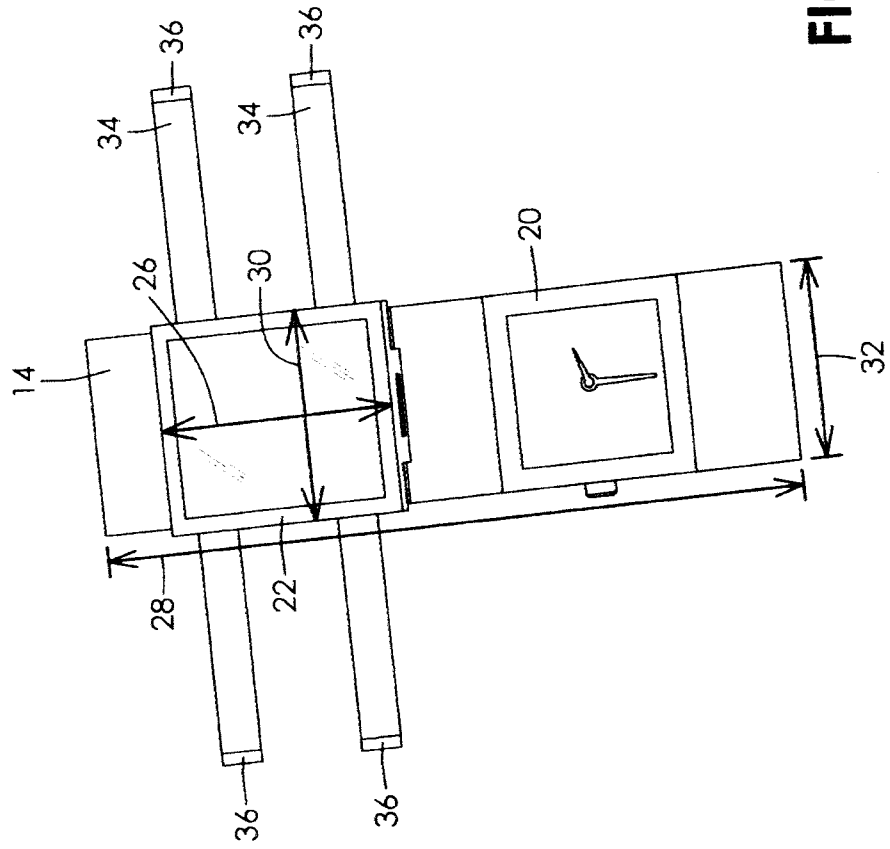


FIG. 1



**FIG. 2**

3/9

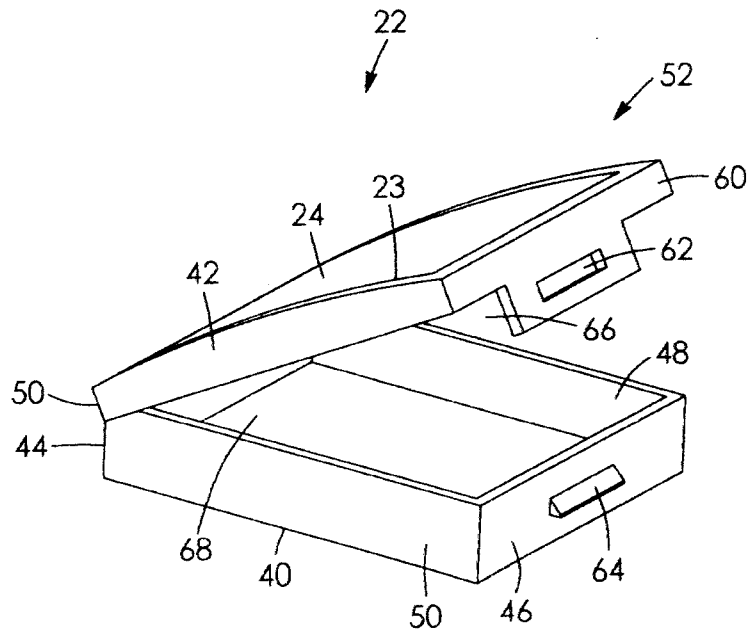


FIG. 3

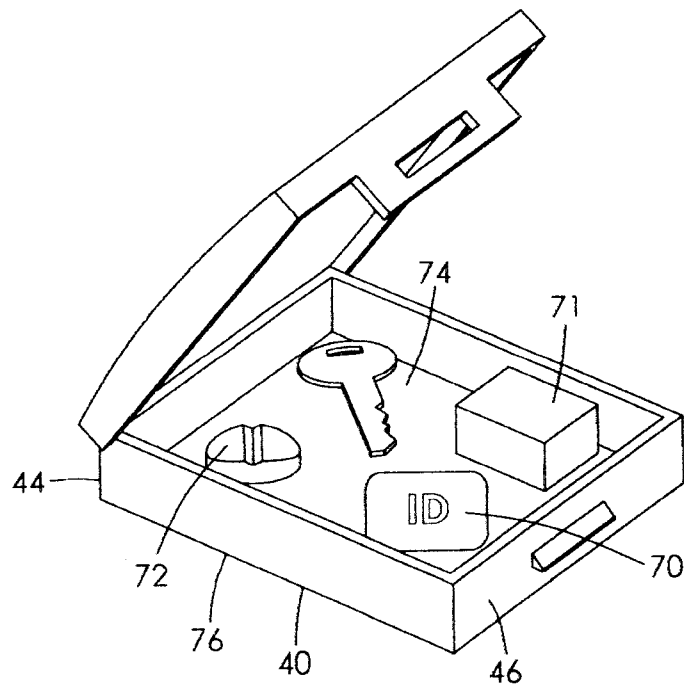
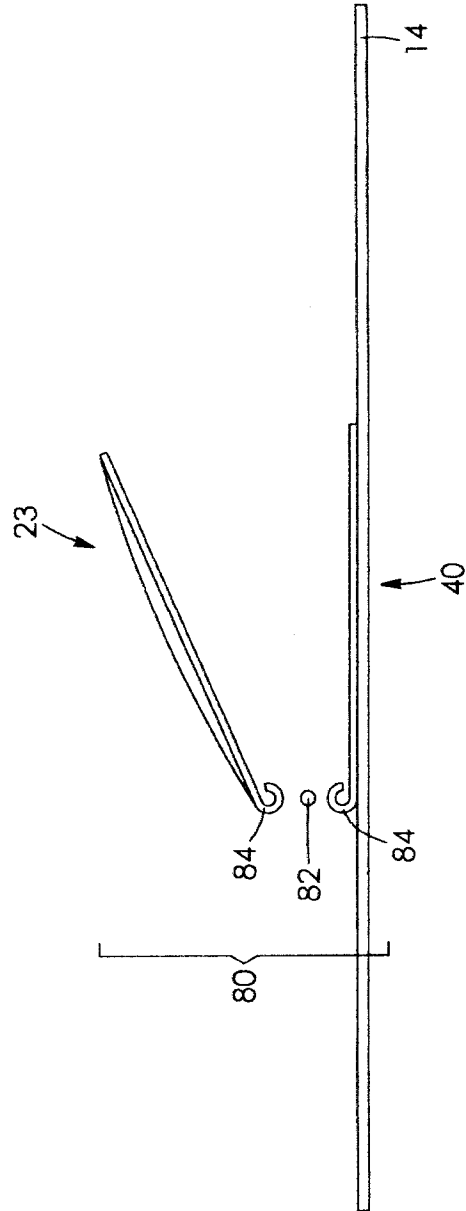
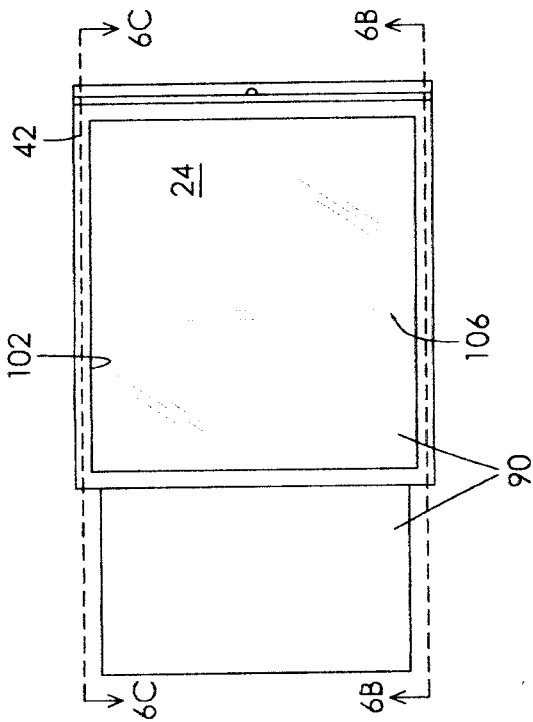


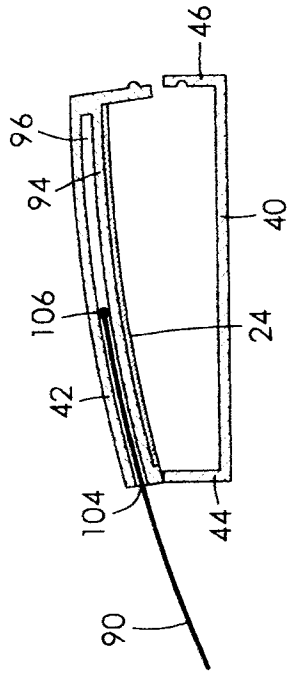
FIG. 4



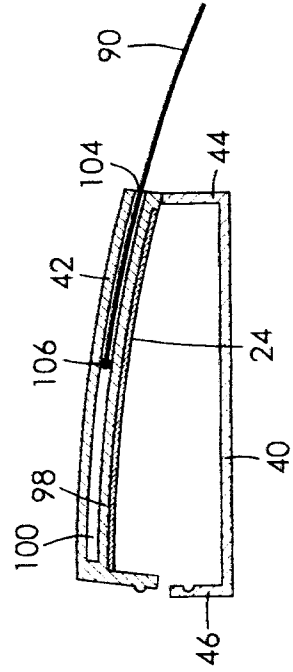
**FIG. 5**



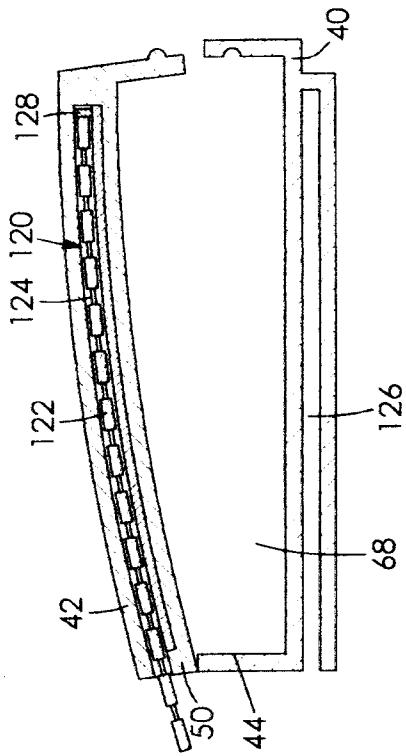
**FIG. 6A**



**FIG. 6B**

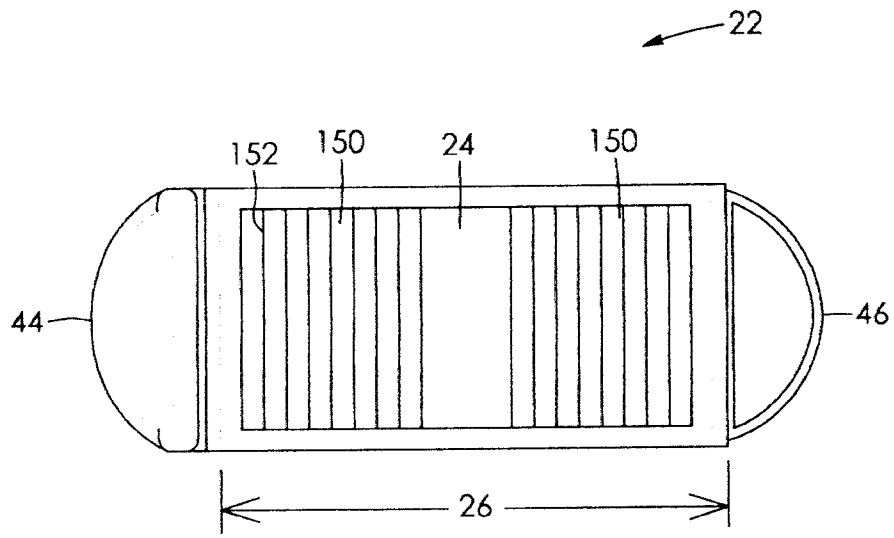


**FIG. 6C**

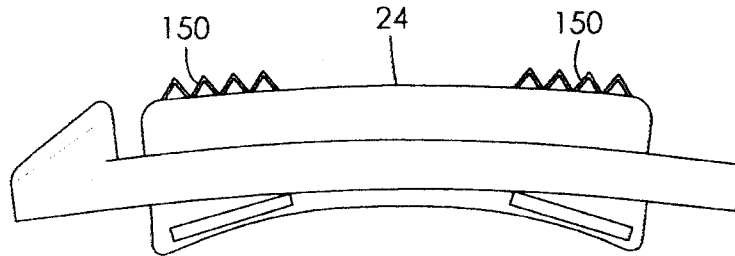


**FIG. 7**

7/9

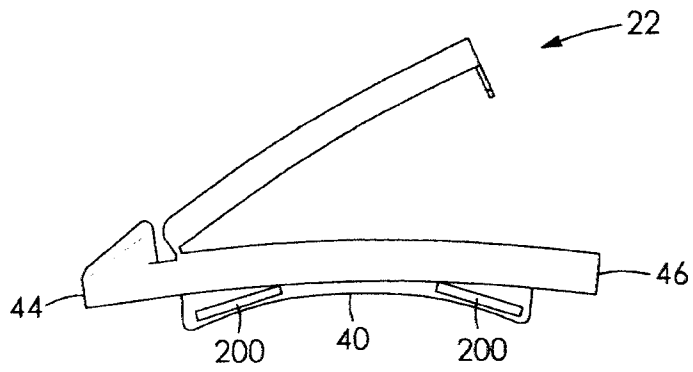


**FIG. 8A**

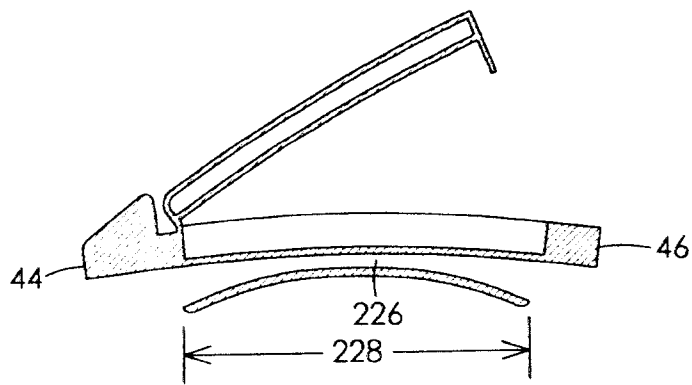


**FIG. 8B**

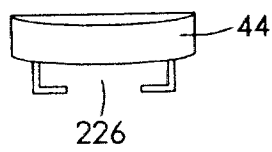
8/9



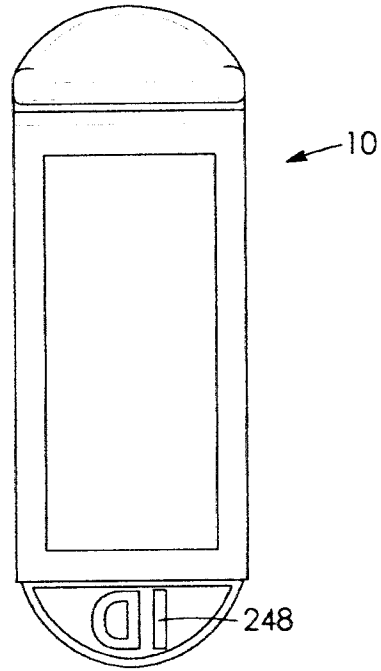
**FIG. 9A**



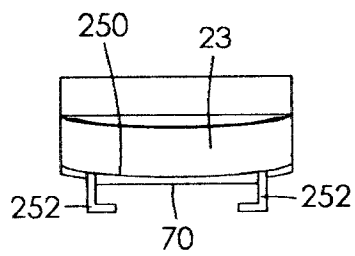
**FIG. 9B**



**FIG. 9C**



**FIG. 10**



**FIG. 11**

## INTERNATIONAL SEARCH REPORT

International application No.

**PCT/CA2017/000229**

<p>A. CLASSIFICATION OF SUBJECT MATTER          IPC: <i>A63B 71/00</i> (2006.01), <i>A41D 20/00</i> (2006.01), <i>A45C 15/04</i> (2006.01), <i>A45D 42/06</i> (2006.01), <i>A45D 42/16</i> (2006.01), <i>A45F 5/00</i> (2006.01) (more IPCs on the last page)</p> <p>According to International Patent Classification (IPC) or to both national classification and IPC</p>																	
<p>B. FIELDS SEARCHED</p> <p>Minimum documentation searched (classification system followed by classification symbols)          IPC (2006.01): A63B 71/00; A41D 20/00; A45C 15/04; A45D 42/06; A45D 42/16; A45F 5/00; A47G 1/02; A63B 71/06; F16M 13/04; G02B 5/10</p> <p>Documentation searched other than minimum documentation to the extent that such documents are included in the fields searched</p> <p>Electronic database(s) consulted during the international search (name of database(s) and, where practicable, search terms used)          Databases: Canadian Patent Database (CPD); Questel™ Orbit™</p> <p>Keywords: mirror, wrist, hinge, strap, clamshell</p>																	
<p>C. DOCUMENTS CONSIDERED TO BE RELEVANT</p> <table border="1"> <thead> <tr> <th>Category*</th> <th>Citation of document, with indication, where appropriate, of the relevant passages</th> <th>Relevant to claim No.</th> </tr> </thead> <tbody> <tr> <td>X Y</td> <td>CA 2 852 308 A1 (CRANE, R. P.) 2 May 2013 (02-05-2013) * fig. 1, 4b; page 5, lines 30-31, page 6, lines 6-8, page 7, lines 4-9, page 7, line 30 to page 8, line 2 *</td> <td>1, 2, 18 and 22 3-5, 9-11, 15-17, 19-21 and 26</td> </tr> <tr> <td>Y</td> <td>GB 1 269 992 (SENG, T. S.) 12 April 1972 (12-04-1972) * fig *</td> <td>3 and 10</td> </tr> <tr> <td>Y</td> <td>FR 2 599 521 (POUPON, P.) 4 December 1987 (04-12-1987) * fig. 1 and 2 *</td> <td>4, 5, 9-11, 15, 16 and 26</td> </tr> <tr> <td colspan="3">Continued...</td> </tr> </tbody> </table>			Category*	Citation of document, with indication, where appropriate, of the relevant passages	Relevant to claim No.	X Y	CA 2 852 308 A1 (CRANE, R. P.) 2 May 2013 (02-05-2013) * fig. 1, 4b; page 5, lines 30-31, page 6, lines 6-8, page 7, lines 4-9, page 7, line 30 to page 8, line 2 *	1, 2, 18 and 22 3-5, 9-11, 15-17, 19-21 and 26	Y	GB 1 269 992 (SENG, T. S.) 12 April 1972 (12-04-1972) * fig *	3 and 10	Y	FR 2 599 521 (POUPON, P.) 4 December 1987 (04-12-1987) * fig. 1 and 2 *	4, 5, 9-11, 15, 16 and 26	Continued...		
Category*	Citation of document, with indication, where appropriate, of the relevant passages	Relevant to claim No.															
X Y	CA 2 852 308 A1 (CRANE, R. P.) 2 May 2013 (02-05-2013) * fig. 1, 4b; page 5, lines 30-31, page 6, lines 6-8, page 7, lines 4-9, page 7, line 30 to page 8, line 2 *	1, 2, 18 and 22 3-5, 9-11, 15-17, 19-21 and 26															
Y	GB 1 269 992 (SENG, T. S.) 12 April 1972 (12-04-1972) * fig *	3 and 10															
Y	FR 2 599 521 (POUPON, P.) 4 December 1987 (04-12-1987) * fig. 1 and 2 *	4, 5, 9-11, 15, 16 and 26															
Continued...																	
<input checked="" type="checkbox"/> Further documents are listed in the continuation of Box C. <input checked="" type="checkbox"/> See patent family annex.																	
<p>* Special categories of cited documents:</p> <p>“A” document defining the general state of the art which is not considered to be of particular relevance</p> <p>“E” earlier application or patent but published on or after the international filing date</p> <p>“L” document which may throw doubts on priority claim(s) or which is cited to establish the publication date of another citation or other special reason (as specified)</p> <p>“O” document referring to an oral disclosure, use, exhibition or other means</p> <p>“P” document published prior to the international filing date but later than the priority date claimed</p>	<p>“T” later document published after the international filing date or priority date and not in conflict with the application but cited to understand the principle or theory underlying the invention</p> <p>“X” document of particular relevance; the claimed invention cannot be considered novel or cannot be considered to involve an inventive step when the document is taken alone</p> <p>“Y” document of particular relevance; the claimed invention cannot be considered to involve an inventive step when the document is combined with one or more other such documents, such combination being obvious to a person skilled in the art</p> <p>“&amp;” document member of the same patent family</p>																
Date of the actual completion of the international search 18 January 2018 (18-01-2018)		Date of mailing of the international search report 23 January 2018 (23-01-2018)															
Name and mailing address of the ISA/CA Canadian Intellectual Property Office Place du Portage I, C114 - 1st Floor, Box PCT 50 Victoria Street Gatineau, Quebec K1A 0C9 Facsimile No.: 819-953-2476		Authorized officer  Jeffrey Butler (819) 934-0087															

## INTERNATIONAL SEARCH REPORT

International application No.

**PCT/CA2017/000229**

## C (Continuation). DOCUMENTS CONSIDERED TO BE RELEVANT

Category*	Citation of document, with indication, where appropriate, of the relevant passages	Relevant to claim No.
Y	US 1 584 205 (ZALDO, E.) 11 May 1926 (11-05-1926) * fig. 3 *	19-21
Y	US 2008/0258917 A1 (BOYD, E. L. et al.) 23 October 2008 (23-10-2008) * par. 0031 *	17

**INTERNATIONAL SEARCH REPORT**  
Information on patent family members

International application No.  
**PCT/CA2017/000229**

Patent Document Cited in Search Report	Publication Date	Patent Family Member(s)	Publication Date
CA2852308A1	02 May 2013 (02-05-2013)	CA2852308A1 AU2012327873A1 AU2012327873B2 BR112014009705A2 CN103889268A EA201400364A1 EA025075B1 EP2770868A1 EP2770868A4 EP2770868B1 ES2633590T3 JP2015501447A JP5930053B2 KR20140096289A KR101621633B1 PH12014501080A1 PH12014501080B1 US2014300981A1 US9445657B2 WO2013059880A1	02 May 2013 (02-05-2013) 15 May 2014 (15-05-2014) 20 August 2015 (20-08-2015) 09 May 2017 (09-05-2017) 25 June 2014 (25-06-2014) 30 July 2014 (30-07-2014) 30 November 2016 (30-11-2016) 03 September 2014 (03-09-2014) 30 September 2015 (30-09-2015) 19 April 2017 (19-04-2017) 22 September 2017 (22-09-2017) 15 January 2015 (15-01-2015) 08 June 2016 (08-06-2016) 05 August 2014 (05-08-2014) 16 May 2016 (16-05-2016) 28 July 2014 (28-07-2014) 28 July 2014 (28-07-2014) 09 October 2014 (09-10-2014) 20 September 2016 (20-09-2016) 02 May 2013 (02-05-2013)
GB1269992A	12 April 1972 (12-04-1972)	None	
FR2599521A1	04 December 1987 (04-12-1987)	None	
US1584205A	11 May 1926 (11-05-1926)	None	
US2008258917A1	23 October 2008 (23-10-2008)	US2008258917A1 US7969314B2 CN101689041A CN101689041B CN106943726A EP2130098A1 EP2487551A2 EP2487551A3 JP2010532673A JP5204836B2 JP2013121547A JP5933465B2 JP2016172016A US2011215934A1 US8248247B2 US2012299725A1 US8421620B2 US2013222134A1 US8854214B2 US2015003214A1 US9250611B2 US2016107030A1 WO2008121856A1	23 October 2008 (23-10-2008) 28 June 2011 (28-06-2011) 31 March 2010 (31-03-2010) 19 April 2017 (19-04-2017) 14 July 2017 (14-07-2017) 09 December 2009 (09-12-2009) 15 August 2012 (15-08-2012) 09 January 2013 (09-01-2013) 14 October 2010 (14-10-2010) 05 June 2013 (05-06-2013) 20 June 2013 (20-06-2013) 08 June 2016 (08-06-2016) 29 September 2016 (29-09-2016) 08 September 2011 (08-09-2011) 21 August 2012 (21-08-2012) 29 November 2012 (29-11-2012) 16 April 2013 (16-04-2013) 29 August 2013 (29-08-2013) 07 October 2014 (07-10-2014) 01 January 2015 (01-01-2015) 02 February 2016 (02-02-2016) 21 April 2016 (21-04-2016) 09 October 2008 (09-10-2008)

*A47G 1/02* (2006.01), *A63B 71/06* (2006.01), *F16M 13/04* (2006.01), *G02B 5/10* (2006.01)