(12) PATENT ABRIDGMENT (11) Document No. AU-B-13258/88
(19) AUSTRALIAN PATENT OFFICE (10) Acceptance No. 607745

(54) Title
HERMETICALLY SEALED SCROLL TYPE COMPRESSOR

International Patent Classification(s)
(51)⁴ **F04C 023/02 F04C 018/02**

(21) Application No. : **13258/88** (22) Application Date : **18.03.88**

(30) Priority Data

(31) Number	(32) Date	(33) Country
62-67355	20.03.87	JP JAPAN
62-67354	20.03.87	JP JAPAN

(43) Publication Date : **22.09.88**

(44) Publication Date of Accepted Application : **14.03.91**

(71) Applicant(s)
SANDEN CORPORATION

(72) Inventor(s)
SHIGEMI SHIMIZU; KIYOSHI TERAUCHI; KAZUTO KIKUCHI

(74) Attorney or Agent
GRIFFITH HACK & CO, GPO Box 1285K, MELBOURNE VIC 3001

(56) Prior Art Documents
US 4314796
US 4340339
AU 27050/77 F04C 1/02

(57) Claim

1. A scroll type compressor within a hermetically sealed housing, the compressor comprising a fixed scroll fixedly disposed within said housing and having an end plate from which a first wrap extends into the interior of said housing, and orbiting scroll having an end plate from which a second wrap extends, said first and second wraps interfitting at an angular and radial offset to form a plurality of line contacts which define at least one pair of sealed off fluid pockets, a driving mechanism including a motor supported in said housing, said driving mechanism being operatively connected to said orbiting scroll to effect the orbital motion of said orbiting scroll, rotation preventing means for preventing the rotation of said orbiting scroll during orbital motion whereby the volume of the fluid pockets changes during orbital motion to compress the fluid in the pockets, said housing including a first shell, a separate second shell and a center block, said center block having a peripheral .../2

(11) AU-B-13258/88
(10) 607745

-2-

portion, said first shell being releasably and hermetically secured to a first side of said peripheral portion of said center block, and said second shell being releasably and hermetically secured to a second side of said peripheral portion of said center block.

10. A scroll type compressor with a hermetically sealing housing, the compressor comprising a fixed scroll fixedly disposed within said housing and having an end plate from which a first wrap extends into the interior of said housing, an orbiting scroll having an end plate from which a second wrap extends, said first and second wraps interfitting at an angular and radial offset to form a plurality of line contacts which define at least one pair of sealed off fluid pockets, a driving mechanism including a motor and a drive shaft supported in said housing, said driving mechanism being operatively connected to said orbiting scroll to effect the orbital motion of said orbiting scroll, rotation preventing means for preventing the rotation of said orbiting scroll during orbital motion whereby the volume of the fluid pockets changes during orbital motion to compress the fluid in the pockets, said housing including a first shell, a separate second shell and a center block, said center block having a peripheral portion and an interior portion located inwardly of the peripheral portion, said first shell being releasably and hermetically secured to a first side of said peripheral portion of said center block, said second shell being releasably and hermetically secured to a second side of said peripheral portion of said center block, a portion of said rotation preventing means being connected to a first side of said interior portion of said center block; one end portion of said drive shaft being rotatably supported in a second opposite side of said interior portion of said center block, a rear bearing support block releasably connected to said second side of said interior portion of said center block, the other end portion of said drive shaft being supported by said rear bearing support block.

COMPLETE SPECIFICATION

(ORIGINAL)

FOR OFFICE USE

Short Title:

Int. Cl:

Application Number:
Lodged:

Complete Specification-Lodged:
Accepted:
Lapsed:
Published:

Priority:

Related Art:

This document contains the
amendments made under
Section 49 and is correct for
printing.

TO BE COMPLETED BY APPLICANT

Name of Applicant:

SANDEN CORPORATION

Address of Applicant: 20 KOTOBUKI-CHO
ISESAKI-SHI
GUNMA-KEN
JAPAN

Actual Inventor:

Address for Service: CLEMENT HACK & CO.,
601 St. Kilda Road,
Melbourne, Victoria 3004,
Australia.

Complete Specification for the invention entitled:
SCROLL TYPE COMPRESSOR

The following statement is a full description of this invention
including the best method of performing it known to me:-

SCROLL TYPE COMPRESSOR

5 Background of the Invention

This invention relates to a scroll type compressor and more particularly, to a motor driven scroll compressor having the compression and drive mechanisms within a hermetically sealed container.

10 Scroll type fluid displacement apparatus are well known in the prior art. For example, U.S. Patent No. 801,182 issued to Creux discloses such an apparatus which includes two scrolls each having a circular end plate and a spiroidal or involute spiral element. The 15 scrolls are maintained angularly and radially offset so

that both spiral elements interfit to form a plurality of line contacts between their spiral curved surfaces to thereby seal off and define at least one pair of fluid pockets. The relative orbital motion of the two scrolls 5 shifts the line contacts along the spiral curved surfaces and, as a result, the volume of the fluid pockets increases or decreases, dependent on the direction of the orbital motion. Thus, a scroll type fluid displacement apparatus may be used to compress, expand or pump fluids.

10 Furthermore, U.S. Patent No. 4,560,330 for example, discloses such a hermetic type scroll compressor which includes a fixed scroll, orbiting scroll, rotation preventing device and driving mechanism in one sealed container.

15 In this hermetic type scroll compressor, the essentially inseparable container is sealed by welding or other means so that leakage of refrigerant gas from the container is completely prevented.

20 While the above mentioned hermetic type scroll compressor prevents leakage of refrigerant gas from the container, this hermetic type scroll compressor can hardly be disassembled and reassembled for inspection, and repair or exchange of parts.

Summary of the Invention

25 It is a primary object of this invention to improve hermetic scroll compressor container to facilitate disassembling and reassembling of a hermetic type scroll compressor by releasably and hermetically securing a first casing and a second casing through the 30 center block to form the hermetically sealed container.

It is another object of this invention to improve hermetic type scroll compressor manufacturing and maintenance efficiencies by assembling a first housing and a second housing of a hermetic type scroll compressor

separately so that the first housing, second housing and components therein can be disassembled, reassembled and inspected independently.

It is yet a further object of this invention to provide a releasably hermetic securing mechanism which also provides alignment means for aligning appropriate components within the first casing with appropriate components within the second casing.

According to the present invention there is provided a scroll type compressor within a hermetically sealed housing, the compressor comprising a fixed scroll fixedly disposed within said housing and having an end plate from which a first wrap extends into the interior of said housing, and orbiting scroll having an end plate from which a second wrap extends, said first and second wraps interfitting at an angular and radial offset to form a plurality of line contacts which define at least one pair of sealed off fluid pockets, a driving mechanism including a motor supported in said housing, said driving mechanism being operatively connected to said orbiting scroll to effect the orbital motion of said orbiting scroll, rotation preventing means for preventing the rotation of said orbiting scroll during orbital motion whereby the volume of the fluid pockets changes during orbital motion to compress the fluid in the pockets, said housing including a first shell, a separate second shell and a center block, said center block having a peripheral portion, said first shell being releasably and hermetically secured to a first side of said peripheral portion of said center block, and said second shell being releasably and hermetically secured to a second side of said peripheral portion of said center block.

According to the present invention there is provided a scroll type compressor with a hermetically sealing housing, the compressor comprising a fixed scroll fixedly disposed within said housing and having an end plate from which a first wrap extends into the interior of said housing, an orbiting scroll having an end plate from



which a second wrap extends, said first and second wraps interfitting at an angular and radial offset to form a plurality of line contacts which define at least one pair of sealed off fluid pockets, a driving mechanism including a motor and a drive shaft supported in said housing, said driving mechanism being operatively connected to said orbiting scroll to effect the orbital motion of said orbiting scroll, rotation preventing means for preventing the rotation of said orbiting scroll during orbital motion whereby the volume of the fluid pockets changes during orbital motion to compress the fluid in the pockets, said housing including a first shell, a separate second shell and a center block, said center block having a peripheral portion and an interior portion located inwardly of the peripheral portion, said first shell being releasably and hermetically secured to a first side of said peripheral portion of said center block, said second shell being releasably and hermetically secured to a second side of said peripheral portion of said center block, a portion of said rotation preventing means being connected to a first side of said interior portion of said center block; one end portion of said drive shaft being rotatably supported in a second opposite side of said interior portion of said center block, a rear bearing support block releasably connected to said second side of said interior portion of said center block, the other end portion of said drive shaft being supported by said rear bearing support block.

Further objects, features and other aspects of this invention will be understood from the detailed description of the preferred embodiment of this invention with reference to the annexed drawings.

Brief Description of the Drawings

Figure 1 is a vertical longitudinal sectional view



of a hermetic type scroll compressor in accordance with one embodiment of this invention.

Figure 2 is a vertical longitudinal sectional view of a hermetic type scroll compressor in accordance with another embodiment of this invention.

Detailed Description of the Preferred Embodiment

Figure 1 depicts a hermetic type scroll refrigerant compressor 1 in accordance with a first embodiment of the present invention. Compressor 1 includes first cup shaped casing 10, second cup shaped casing 20 and center block 30 which is attached to first cup shaped casing 10 and second cup shaped casing 20. Opening or bore 31 is formed in the center of center block 30 for receiving drive shaft 11. Radial projection 301 is formed in the inner peripheral surface of opening 31. Drive shaft 11 is rotatably supported in opening 31 by bearing 33. Bearing 33 firmly fits in opening 31. Outer ring 33a of bearing 33 is stopped at a rear end surface of radial projection 301. Nut 34 is screwed on drive shaft 11 and faces one end surface of inner ring 33b of bearing 33. Flange 111 located at one end of drive shaft 11 faces the other end surface of inner ring 33b of bearing 33. Axial motion of drive shaft 11 is

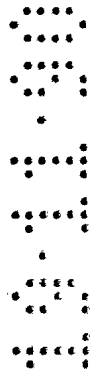

thereby prevented by flange 111 and nut 34. Rotor 40a of motor 40 surrounds drive shaft 11. Rotor 40a may be firmly inserted over drive shaft 11.

Fixed scroll 50 includes circular end plate 51 and wrap or spiral elements 52 affixed to or extending from one end surface of end plate 51. Fixed scroll 50 is fixed within the inner chamber of first cup shaped casing 10 by screws 11 screwed into end plate 51 from outside of first cup shaped casing 10. Seal ring 11b is located between an inner surface of screw flange 11a and the outer end surface of first cup shaped casing 10 to seal the connection therebetween. Circular end plate 51 of fixed scroll 50 partitions the inner chamber of first cup shaped casing 10 into two chambers, such as front chamber 15 18 and rear chamber 19.

Orbiting scroll 60 is disposed at the rear end side of center block 30 through later mentioned rotation preventing/thrust bearing device 45. Orbiting scroll 60 includes circular end plate 61 and wrap or spiral elements 62 affixed to or extending from one end surface of circular end plate 61. Annular projection 16 is formed opposite the surface of circular end plate 61 from which spiral element 62 extends. Bearing 16d is disposed within the inner peripheral wall of the annular projection 16.

Bushing 115 is attached to one end of drive shaft 11 at a radial offset through pin member 115b. Bushing 115 is inserted into annular projection 16 of orbiting scroll 60. Orbiting scroll 60 is rotatably supported by bushing 115 through bearing 16d placed on the outer peripheral surface of bushing 115.

Rotation preventing/thrust bearing device 45 is placed between the rear end surface of center block 30 and the end surface of circular end plate 61. Rotation preventing/thrust bearing device 48 includes fixed ring 451 attached on the axial end surface of annular

projection 302 which is formed in the rear end surface of center block 30, orbiting ring 452 attached on the end surface of circular end plate 61, and a plurality of bearing elements, such as balls 453, placed between 5 pockets 451a, 452a formed by rings 451, 452. The rotation of orbiting scroll 60 during orbital motion is prevented by the interaction of balls 453 with rings 451, 452. Also, the axial thrust load from orbiting scroll 60 is supported on center block 30 through balls 453. While 10 orbiting scroll 60 orbits, the rotation of orbiting scroll 60 is prevented by rotation preventing/thrust bearing device 45.

In this situation, spiral element 62 of orbiting scroll 60 interfits spiral element 52 of fixed 15 scroll 50 at an annular offset of 180° and at a predetermined radial offset. Spiral elements 62 and 52 define at least one pair of sealed off fluid pockets between their interfitting surfaces.

Radial projection 303 formed in the outer 20 peripheral surface of center block 30 is fixed to the axial end surface of first cup shaped casing 10 by screws 12. Seal ring 12a is disposed within circumferential groove 12b of annular projection 302 to form a seal between the inner wall of first cup shaped casing 10 and 25 the outer peripheral surface of annular projection 302.

The other end of drive shaft 11 is also rotatably supported by supporting block (rear bearing unit) 70 through bearing 71. Stator 40b of motor 40 is held firmly between center block 30 and rear bearing unit 30 70. Rear bearing unit 70 is fixed to center block 30 by screws 13 screwed into center block 30 from the rear end of rear bearing unit 70. Therefore, stator 40b is held firmly between center block 30 and rear bearing unit 70. The inner peripheral surface of stator 40b and the outer 35 peripheral surface of rotor 40a face each other.

Rear bearing unit 70 and motor 40 are covered by second cup shaped casing 20. Flange 21a formed at opening end 21 of second cup shaped casing 20 is fixed to radial projection 303 of center block 30 by screws 14.

5 Seal ring 14a is disposed within a circular groove 14h of flange 21a to form a seal between the front end surface of radial projection 303 and an axial end surface of flange 21a.

10 Wires 411 from stator 40b are connected with terminals 412a. Terminals 412a are connected to an external electrical source (not shown) through a switch (also not shown). hermetic seal base 412 is insulated from terminals 412a and fixed to projection 413 which is formed on side surface of second cup shaped casing 20 by
15 screws 414. Seal ring 414a is disposed within a circular groove 414b of projection 413 to form a seal between the rear end surface of hermetic seal base 412 and the axial end surface of projection 413.

By turning on the motor 40, the magnetic field
20 of stator 40b is generated so that rotor 40a begins rotation, thereby rotating drive shaft 11. This rotation is transferred to orbiting scroll 60 through bushing 115. Orbiting scroll 60 begins orbital motion due to rotation prevention/thrust bearing device 45. Refrigerant gas is
25 introduced to inner chamber 25 of second cup shaped casing 21 through inlet port 20c which is formed at the side wall of second cup shaped casing 20, and flows through front chamber 18 of first cup shaped casing 10 through bearing 33 and then through rotation
30 preventing/thrust bearing device 45. The refrigerant gas in the front chamber is taken into the sealed fluid pockets between the fixed scroll and orbiting scroll, then moves toward the center of the spiral wraps during the orbital motion of the orbiting scroll with a
35 resultant volume reduction and compression, and is discharged to rear chamber 19 as through hole 56 and

one-way valve 56c. Discharged gas in the rear chamber then flows to an external fluid circuit (not shown) through outlet port 10c.

Referring to Figure 2, hermetic type scroll refrigerant compressor 1 is shown in accordance with another embodiment of the present invention. The same construction is accorded like numerals as that shown in Figure 1. The description of that constructions is substantially omitted to simplify the description herein.

10 Orbiting scroll 60 interfits fixed scroll 50. Annular projection 16 is formed opposite the surface of circular end plate 61 from which spiral element 62 is extended. Bearing 16d is disposed within the inner peripheral wall of the annular projection 16. A first 15 center block 310 having central opening or bore 311 is disposed adjacent to rotation preventing/thrust bearing device 45. The first center block 310 is releasably and hermetically secured fixed to an axial end surface of first cup shaped casing 10 by screws 12. Seal ring 12a 20 is disposed within a circumferential groove 12b of annular projection 312 formed at the rear end surface of the center block 310 to form a seal between the inner wall of the first cup shaped casing 10 and the outer peripheral surfaces of annular projection 312. A first 25 housing 100 includes the first center block 310 and the first cup shaped casing 10 having fixed scroll 50, orbiting scroll 60 and rotation preventing/thrust bearing device 45 therein. Compression mechanism section 110 comprises a first center block 310 and the construction 30 to the right thereof as shown in Figure 2.

Second center block 320 rotatably supports drive shaft 11 in center block central opening or bore 321 through bearing 33. One end of drive shaft 11 is rotatably supported by rear bearing unit 70 through 35 bearing 71. Stator 40b of motor 40 is held between the second center block 320 and rear bearing unit 70. Rear

bearing unit 70 is releasably secured to the second center block 320 by screws 13. Thus, driving mechanism section 120 is to the left of first center block 310 as shown in Figure 2.

5 The second center block 320 is positioned firmly within second cup shaped casing 20 and against ridge 323 formed in the inner wall of the second cup shaped casing 20. A second housing 200 includes the driving mechanism section 120 and the second cup shaped
10 casing 20. Bushing 115 is attached to one end of drive shaft 11 at a radial offset through pin member 115b.

 The first housing 100 and the second housing 200 are fitted together so that bushing 115 is inserted into annular projection 18 of circular end plate 61.
15 Drive shaft 11 is attached to orbiting scroll at a radial offset. Flange 21a formed at opening end 21 of second cup shaped casing 20 is releasably and hermetically secured to radial projection 313 of first center block 310 by screws 14 and seal ring 14a. Seal ring 14a is
20 disposed within a circular groove 14b of flange 21a to form a seal between the front end surface of radial projection 313 and the axial end surface of flange 21a. Annular projection 322 and the recess defined by projection 312 form an alignment mechanism for aligning
25 drive shaft 11 with the orbiting scroll when first housing 100 and second housing 200 engage first center block 310. As a result, hermetically sealed compressor housing 400 is formed.

 Although illustrative embodiments of the
30 invention have been described in detail with respect to the accompanying drawings, it is to be understood that the invention is not limited to those precise embodiments, and that various changes and modifications may be effected therein by one skilled in the art without
35 departing from the scope of the invention.

THE CLAIMS DEFINING THE INVENTION ARE AS FOLLOWS:

1. A scroll type compressor within a hermetically sealed housing, the compressor comprising a fixed scroll fixedly disposed within said housing and having an end plate from which a first wrap extends into the interior of said housing, and orbiting scroll having an end plate from which a second wrap extends, said first and second wraps interfitting at an angular and radial offset to form a plurality of line contacts which define at least one pair of sealed off fluid pockets, a driving mechanism including a motor supported in said housing, said driving mechanism being operatively connected to said orbiting scroll to effect the orbital motion of said orbiting scroll, rotation preventing means for preventing the rotation of said orbiting scroll during orbital motion whereby the volume of the fluid pockets changes during orbital motion to compress the fluid in the pockets, said housing including a first shell, a separate second shell and a center block, said center block having a peripheral portion, said first shell being releasably and hermetically secured to a first side of said peripheral portion of said center block, and said second shell being releasably and hermetically secured to a second side of said peripheral portion of said center block.

2. The hermetically sealed scroll type compressor of Claim 1, wherein said scrolls are surrounded by said first shell and said motor including a rotor and stator is surrounded by the second shell.

3. The hermetically sealed scroll type compressor of Claim 2, further comprising said fixed scroll being releasably and hermetically secured to the first shell.

4. The hermetically sealed scroll type compressor of Claims 1, 2 or 3, wherein each shell is cup shaped.



5. The hermetically sealed scroll type compressor of Claim 1, wherein said center block is formed as a single piece element having said peripheral portion including receiving releasable fastening means for securing said first and second shells to said center block and an interior portion for rotatably supporting a portion of said drive mechanism.

6. The hermetically sealed scroll type compressor of Claim 1, wherein said center block is formed of a first block and a second separate block, said first block having said peripheral portion for receiving releasable fastening means for securing said first and second shells to said center block, said second block having an interior portion for rotatably supporting a portion of said drive mechanism.

7. The hermetically sealed scroll type compressor of Claims 5 or 6 wherein at least a portion of said fastening means securing one of said first and second shells to said center block element is disposed within the other of said first and second shell.

8. The hermetically sealed scroll type compressor of Claim 7, wherein at least a portion of said fastening means securing said first shell to said center block is disposed within said second shell.

9. The hermetically sealed scroll type compressor of Claim 8, wherein said scrolls are surrounded by said first shell and said motor including a rotor and a stator are surrounded by said second shell.

10. A scroll type compressor with a hermetically sealing housing, the compressor comprising a fixed scroll fixedly disposed within said housing and having an end plate from which a first wrap extends into the interior of said housing, an orbiting scroll having an end plate from which a second wrap extends, said first and second wraps interfitting at an angular and radial offset to form a plurality of line contacts which define at least



one pair of sealed off fluid pockets, a driving mechanism including a motor and a drive shaft supported in said housing, said driving mechanism being operatively connected to said orbiting scroll to effect the orbital motion of said orbiting scroll, rotation preventing means for preventing the rotation of said orbiting scroll during orbital motion whereby the volume of the fluid pockets changes during orbital motion to compress the fluid in the pockets, said housing including a first shell, a separate second shell and a center block, said center block having a peripheral portion and an interior portion located inwardly of the peripheral portion, said first shell being releasably and hermetically secured to a first side of said peripheral portion of said center block, said second shell being releasably and hermetically secured to a second side of said peripheral portion of said center block, a portion of said rotation preventing means being connected to a first side of said interior portion of said center block; one end portion of said drive shaft being rotatably supported in a second opposite side of said interior portion of said center block, a rear bearing support block releasably connected to said second side of said interior portion of said center block, the other end portion of said drive shaft being supported by said rear bearing support block.

11. The hermetically sealed scroll type compressor of Claim 10, wherein said center block is formed as a single piece element.

12. The hermetically sealed scroll type compressor of Claim 10, wherein said center block is formed of a first block and a second separate block, said first block including said peripheral portion and said first side of



said interior portion of said center block, and said second block including said second side of said interior portion of said center block.

13. The hermetically sealed scroll type compressor of Claim 12, wherein said second block has an annular projection concentrically disposed about said drive shaft, and said first block comprising an annular portion concentrically disposed about said drive shaft and having an annular recess in the wall thereof, said recess having an abutment surface substantially normal to the drive shaft center line, the annular projection and recess cooperating to form an alignment means for aligning said drive shaft with the orbiting scroll.

14. The hermetically sealed scroll type compressor of Claim 13, wherein the first block and second block each have a surface which extends radially outwardly from said first block annular portion and said second block annular projection respectively, and each surface is frustoconical.

15. The hermetically sealed scroll type compressor of Claims 10, 11, 12 or 13 wherein said scrolls are surrounded by said first shell and said motor including a rotor and a stator are surrounded by said second shell.

16. The hermetically sealed scroll type compressor of Claim 15, wherein said fixed scroll is releasably and hermetically secured to said first shell.



17. The hermetically sealed scroll type compressor according to Claims 10, 11, 12 or 13 wherein the improvement further comprises each shell being cup shaped.

18. A scroll type compressor substantially as hereinbefore described with reference to the accompanying drawings.

DATED THIS 19TH DAY OF NOVEMBER 1990

SANDEN CORPORATION

By its Patent Attorneys:

GRIFFITH HACK & CO

Fellows Institute of Patent
Attorneys of Australia

1990
NOV
19

1990
NOV
19



15 0 0 1 3 5 0

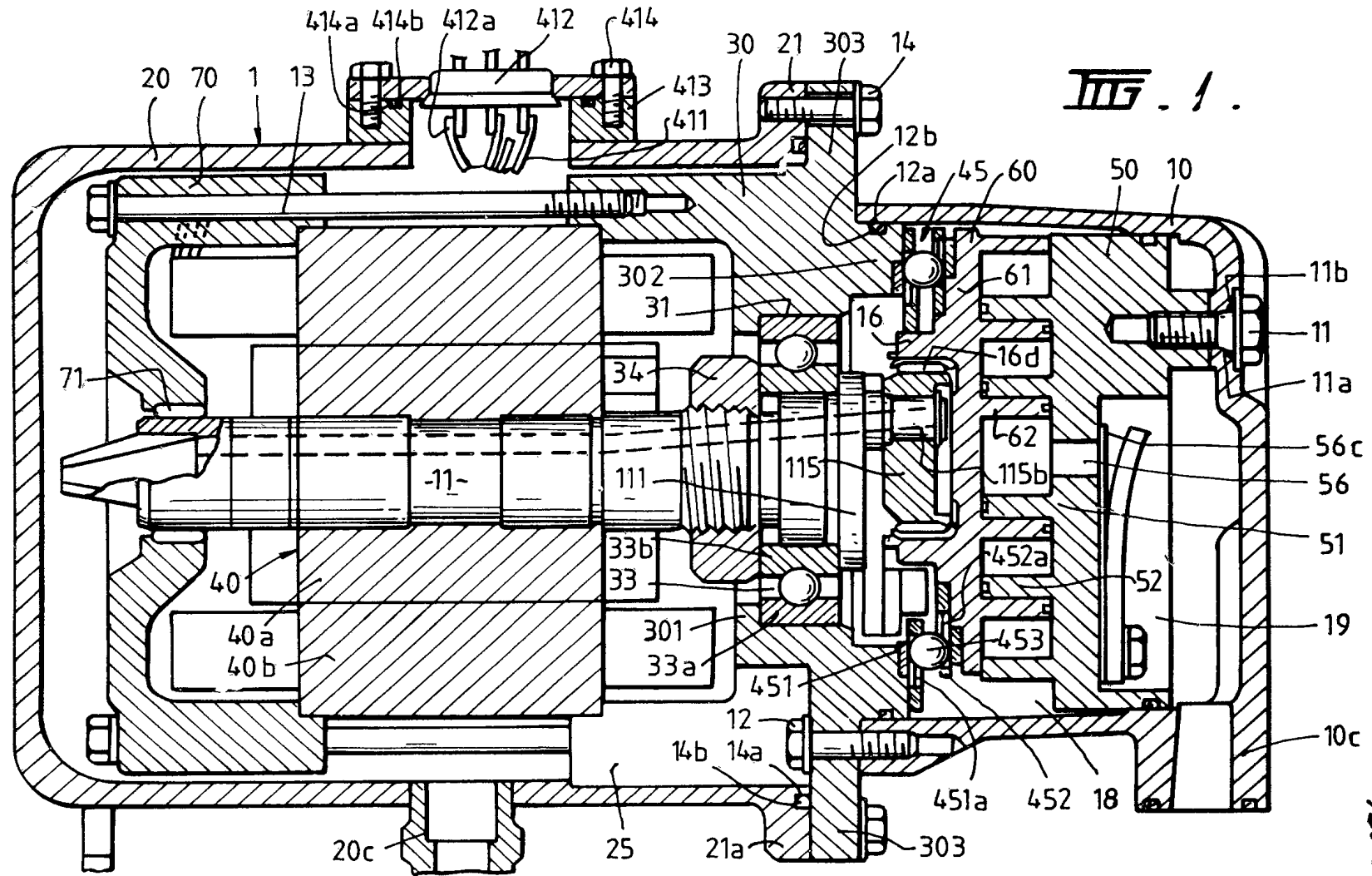

III. 1.

13258/88

15 00 1050

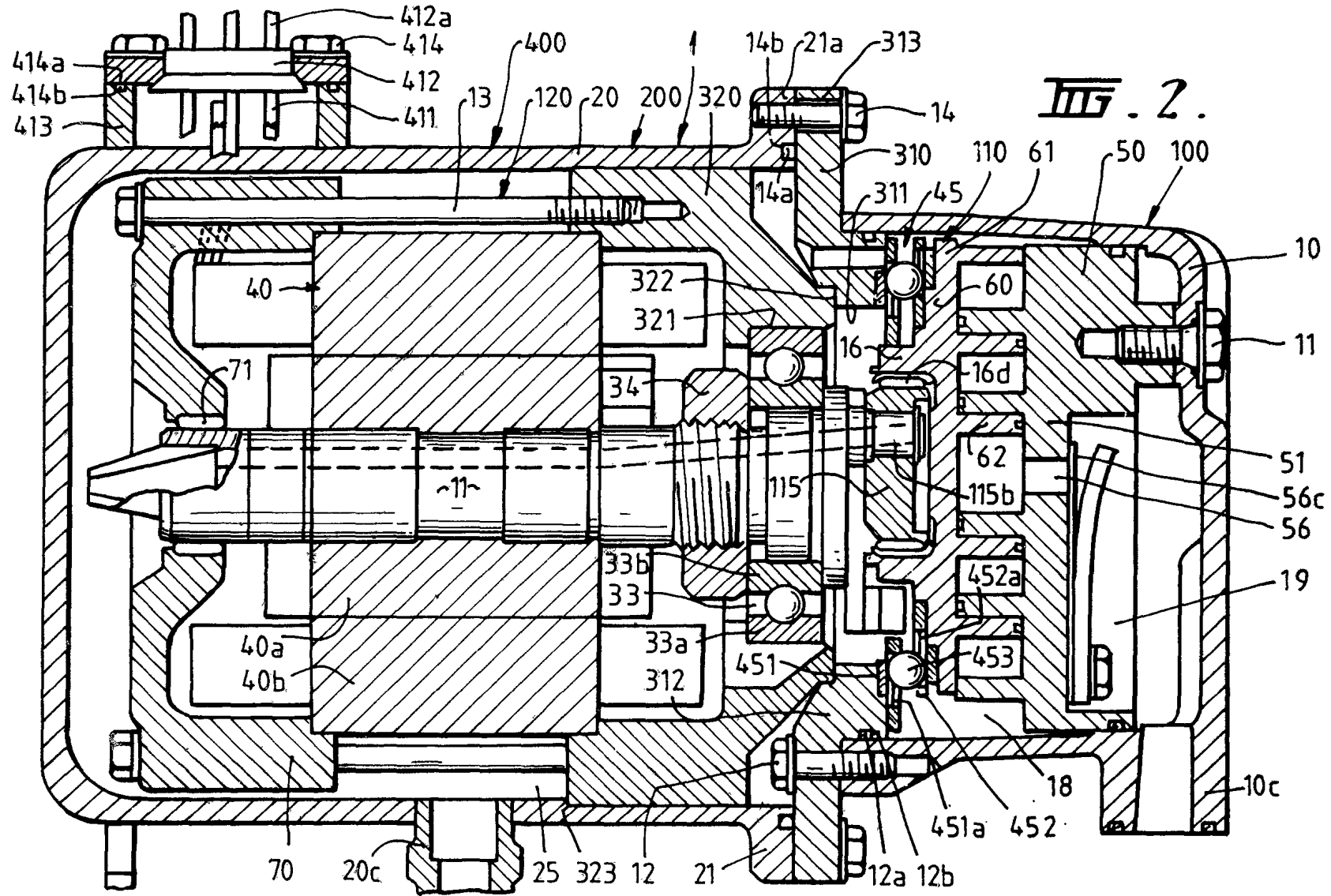

FIG. 2.