

C. W. BALDWIN.
ELEVATOR.

No. 109,169

Patented Nov. 15, 1870.

Fig. 1.

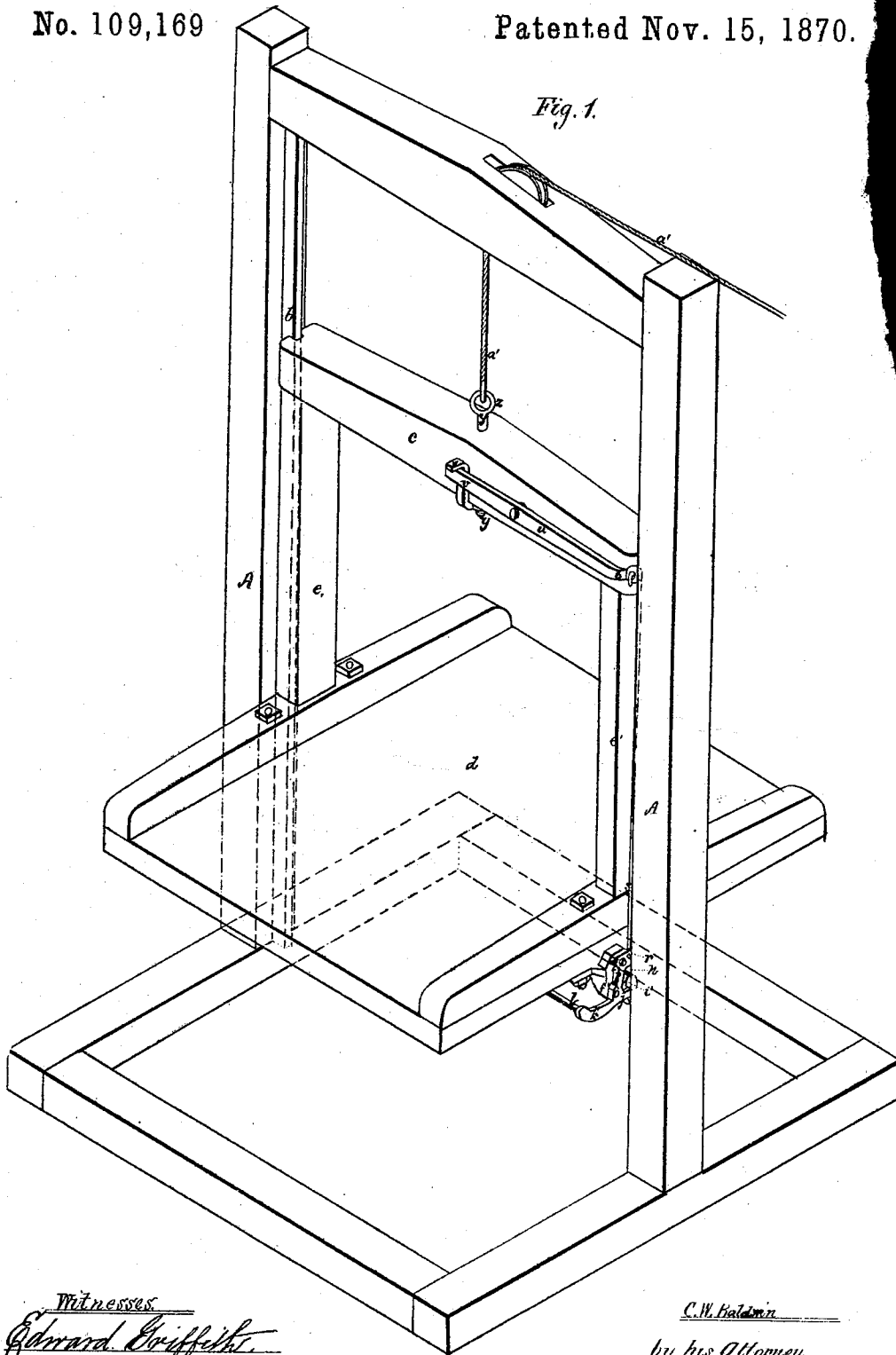

Witnesses
Edward Griffiths
Edmund H. Heurins

C. W. Baldwin
by his Attorney
Frederick Curtis

C. W. BALDWIN.
ELEVATOR.

No. 109,169

Patented Nov. 15, 1870.

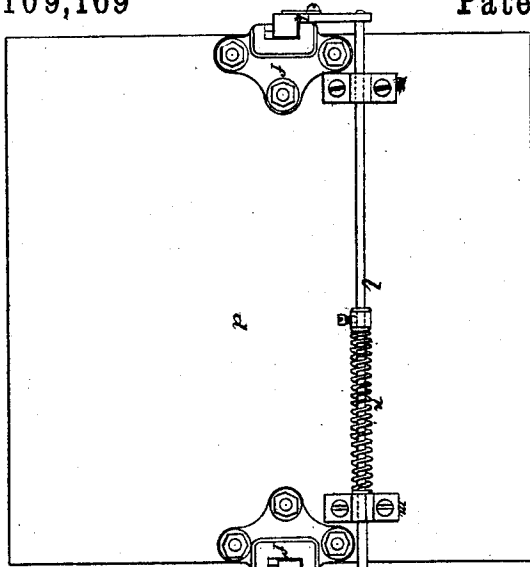

Fig. 2.

Witnesses
Edmond B. Smith
Edmund M. Stevens

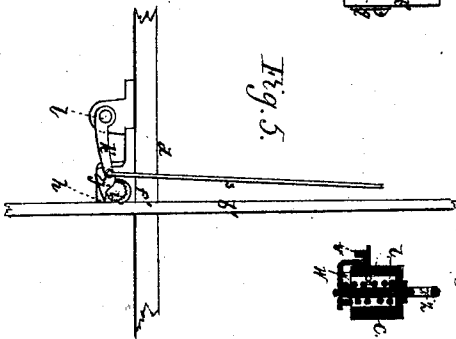

Fig. 5.



Fig. 4.



Fig. 6.
Side view of bracket.

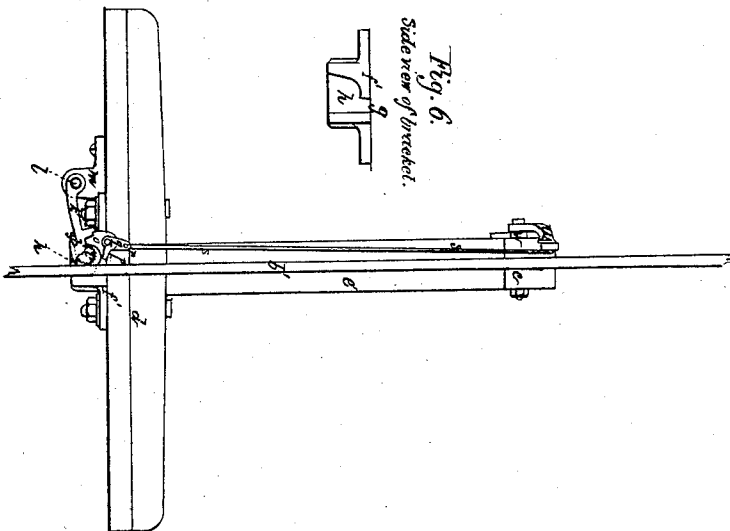

Fig. 3.

C. W. Baldwin
 by his Attorney
Frederick S. Gault

United States Patent Office.

CYRUS W. BALDWIN, OF BOSTON, MASSACHUSETTS.

Letters Patent No. 109,169, dated November 15, 1870.

IMPROVEMENT IN ELEVATORS.

The Schedule referred to in these Letters Patent and making part of the same

To all to whom these presents shall come:

Be it known that I, CYRUS W. BALDWIN, of Boston, in the county of Suffolk and State of Massachusetts, have made an invention of certain new and useful Improvements in Elevators for Buildings, &c.; and do hereby declare the following to be a full, clear, and exact description thereof, due reference being had to the accompanying drawing making part of this specification, and in which—

Figure 1 is a perspective view of my invention;

Figure 2 is an under-side view of the platform of its carriage;

Figure 3, a side elevation of its carriage and adjuncts; while

Figure 4 is a vertical and longitudinal section of the cross-head of the carriage.

My present invention may be considered in the light of an improvement upon that for which Letters Patent of the United States were issued to me on the 19th day of November, 1867, for improvement in elevators.

My present invention possesses characteristics in themselves independent of such Letters Patent, although suggested by them, and relates to means not only for reducing the number of composite parts of the device and simplifying its construction, but to vastly simplify its operation, or the number of movements before necessary to release the locking or safety device.

The construction and arrangement of parts which secure the above results also serve to cause the locking device to "set" itself automatically upon ascent of the elevator-carriage, being, in this respect, a great improvement upon the construction shown in Letters Patent before mentioned.

The invention or improvement also relates to means for providing against accidental fall of the platform of the carriage, should the cross-head or other portion of such carriage to which is usually applied the safety device or stop.

As heretofore constructed, the safety device or stop of elevator-carriages has been applied to the cross-head, or other portion of the carriage disposed above its platform. Consequently, upon breaking of any portion of the carriage above its platform, the safety device becomes useless, and the platform is allowed to descend unchecked to the floor, with the usual fatal results to life and property.

To provide a means of remedying this latter objection, my invention consists in applying the safety device hereafter explained to the under side of the platform; consequently the fracture or failure of any portion of the carriage cannot destroy the action of such device.

My present invention further consists in disposing

loosely, within certain clasps or recessed brackets affixed to the lower surface of the platform of the elevator-carriage, and embracing opposite sides of its supporting-slides or guides, two fluted or roughened rollers or circular disks, these rollers resting upon and being retained in place within the bracket and upon one side of the slide by means of two tripping-levers secured to a horizontal shaft extending transversely across the under side of the platform, the shaft being in turn controlled and actuated by a spring and by a pallet and lever, as hereinafter explained, and the whole being so arranged and operating that, upon fracture of the supporting-rope or chain of the carriage, the free ends of the tripping-levers before mentioned shall rise with a sudden snap, and throw the rollers upward and between the clasp and supporting-slides, between which they become tightly wedged, and so as to lock the carriage or its platform tightly to such slides.

In the drawing before alluded to as accompanying this specification—

A A denote two upright beams or posts for supporting the elevating-carriage, the slides or ways for guiding the vertical movements of such carriage being shown at *b b'*, as applied to opposite inner faces of the posts in the usual manner.

The cross-head of the elevator-carriage is shown at *c* and its platform at *d*, the posts or rods connecting the two being shown at *e e'*.

The extremities of the cross-head straddle the slides *b b'*, while the lower surface of the opposite sides of the platform *d* is provided with twin-shaped strong recessed brackets or clasps, *f f'*, a portion, *g*, of the recessions of such brackets serving to embrace the slides, while the lower and larger portion *h* of such depression or groove serves to receive a fluted roller, *i* or *i'*, which is disposed loosely within it, the said portion *h* being open at bottom, as represented in Figure 5 of the accompanying drawing.

By referring to such figure the reader will see that the portion *h* of the recess of the brackets is angular, or slightly converging at its upper part, and of such size that this upper part, with the slide *b* inclosed, shall be of somewhat less diameter than that of the fluted roller; hence, it will be obvious that, as this roller is suddenly forced upward and caught between the boundary of the opening *h* and the slide *b'*, the descent of the platform serves to wedge or force the roller tightly between such parts, and clamp the brackets, and consequently the platform, securely to the slides, and instantly arrest any further descent of said platform.

The rollers *i* or *i'* rest upon the free ends *j* of two tripping-levers, *k k'*, which are fixed to opposite ends of a horizontal rocker-shaft or rod, *l*, extending trans

versely of the under side of the platform *d*, and supported in suitable boxes, *m m'*, applied thereto, a coiled or other spring, *n*, being suitably applied to the shaft, in such manner as to maintain the free ends of the levers *k k'* in contact with the lower surface of the brackets *f f'*, and so as to cover the lower opening of the recess *h* and prevent escape of the rollers therefrom.

One of the levers or trippers, *k*, is provided with a small notched projection, *o*, this notch being for reception of the free end *p* of a right-angular bent pawl or trigger, *q*, fulcrumed to the outer face of one of the brackets, *f*, and immediately in rear of its roller recess, the upper arm *r* of such pawl being pivoted to the lower end of a connecting-rod, *s*, which extends up alongside of one of the posts *e* of the elevator-carriage, the opposite end of such rod in turn being pivoted to the outer extremity of the longer arm *t* of a lever, *u*, which is fulcrumed to the front face of the cross-head *c* of the carriage, as represented.

The extremity of the shorter arm *v* of the lever *u* is extended to the center of the cross-head *c*, where it supports upon its upper surface a bracket or bent support, *w*, such bracket being depressed by a coiled or other spring, *x*, disposed within or upon the upper part of the cross-head, a bolt, *y*, having upon its upper extremity an eye, *z*, being extended through the cross-head and screwing into the lower part of the bracket *w*, as shown in fig. 4 of the drawing.

A rope or chain, *a'*, is to be secured to the eye *z* of the bolt *y*, and thence carried to the hoisting mechanism in the usual manner.

The above constitutes the mechanical construction of my invention, the operation of which may be thus explained:

The weight of the elevator-carriage, with or without the load, forces upward the bracket *w*, and away from contact with the lever *u*, and thus remains during the ordinary working of the elevator-carriage.

To adjust the safety device covered by my invention so as to prepare for accidents, the tripping-levers are to be depressed sufficiently far to allow the lower and free end of the trigger to be inserted within the notch before alluded to as formed in one of them.

The spring of the shaft *l* serves to retain the trigger in contact with the notch at all times during the rise and descent of the carriage, until accidental fracture or slacking of the rope from any cause ensues.

The slacking of the rope has the effect of instantly allowing the bracket *w*, by means of its spring, to be depressed, this lowering of the bracket having the effect of raising the outer arm of the lever *u*, and, by means of the rod *s*, release the trigger from contact with the notch of the tripping-lever, and permit the spring of the rocker-shaft to elevate the levers with a sudden snap, and throw the rollers upward between their respective brackets and the slides *b b'*, in manner and with results before explained.

The above description of the nature and operation of my invention will enable mechanics to construct and explain it, it being remarked that, to adjust the safety device for use, the tripping-levers are to be depressed by hand, and the trigger *q* inserted within the notch of one of them. On releasing the hold of the lever the spring of the shaft *l* serves to maintain the contact of the trigger and lever until fracture of the supporting-rope or chain.

In order to dispense with the necessity of thus "setting" the safety device, and enable such setting to be

done automatically, upon the first ascent of the elevator or carriage after breakage of its supporting-rope, I pivot the lower ends of the rods *s* directly to one of the tripping-levers *k*, as shown in fig. 5 of the accompanying drawing, which is a side elevation of one of such levers and the parts immediately contiguous thereto, it being understood that the spring *n* of the shaft *l* is dispensed with in this instance.

By thus pivoting the rods to the lever it will be obvious that, as the bracket is drawn upward, with respect to the cross-head, by the weight of the carriage, as the rope is drawn taut the levers *k k'* drop by their own gravity and that of the rod *s*, thus allowing the rollers *i i'* in like manner to fall with them, and release the grip of the carriage upon its supporting ways.

I have contemplated the application of the principle of my present invention to elevators formerly constructed, in which toothed racks and two bent levers, operated by a semi-elliptic spring, and provided with lateral bolts for taking into the teeth before mentioned upon breakage of the rope, were the means employed for arresting the accidental descent of the carriage.

As so constructed, the supporting-rope is at all times connected to the eye-bolt, and, consequently, to the safety device, and thus is liable, by being caught and drawn taut accidentally at any time after the breakage or release thereof, to release the hold of the bolts upon the racks, and start the carriage again upon its illegitimate descent.

By means of my present invention, applied to such old construction of parts, the hold of the rope is at once entirely released from connection with the safety locking device upon breakage or slackening of such rope, and, consequently, such device retains an undisturbed hold of the supporting-slides of the carriage.

Claims.

I claim as my invention and desire to secure by Letters Patent of the United States—

1. The safety-catch or locking device, applied to the lower part of the carriage-platform of the elevator, substantially in the manner and for the purposes shown and set forth.

2. As a safety device, for arresting the accidental fall of an elevator-carriage, the employment of the fluted rollers *i i'*, operating in connection with the recessed brackets *f f'* or their equivalents, to embrace opposite sides of, and clasp or clamp the supporting-slides or guides of such carriage, in manner and operating substantially as before explained.

3. As a means of actuating or raising the rollers *i i'*, as well as forming a support to the same, the employment of the tripping-levers *k k'*, supported by the shaft *l*, and operated by the bracket *w* or its equivalent, essentially in manner as herein shown and explained.

4. The combination and arrangement of the rollers *i i'*, levers *k k'*, (supported by the shaft *l*, provided with the spring *n*), trigger *q*, lever *u*, and bracket *w*, the trigger *q* being connected with the lever *u* by the rod *s*, and the bracket *w* provided with the spring *x*, and the whole operating, in connection with the recessed brackets *f f'* and the slides *b*, in manner and for the purpose as before explained.

CYRUS W. BALDWIN.

Witnesses:

FRED. CURTIS,
EDWARD GRIFFITH.