

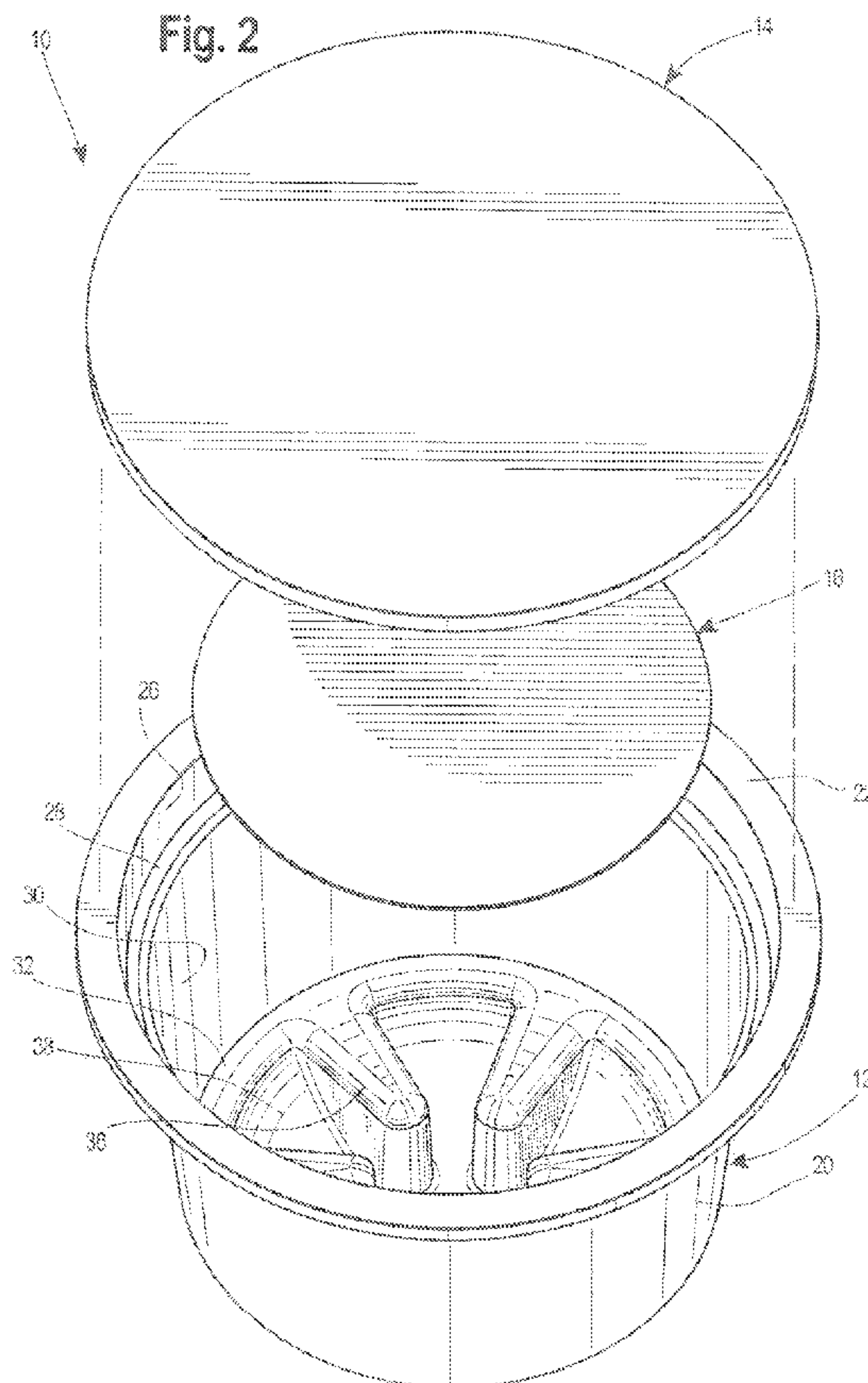

(86) Date de dépôt PCT/PCT Filing Date: 2012/03/08
 (87) Date publication PCT/PCT Publication Date: 2012/09/13
 (85) Entrée phase nationale/National Entry: 2013/09/04
 (86) N° demande PCT/PCT Application No.: US 2012/028185
 (87) N° publication PCT/PCT Publication No.: 2012/122329
 (30) Priorités/Priorities: 2011/03/08 (GB1103953.4);
 2011/03/08 (US61/450,548)

(51) Cl.Int./Int.Cl. *B65D 85/804* (2006.01)
 (71) Demandeur/Applicant:
 KRAFT FOODS R & D, INC., US
 (72) Inventeur/Inventor:
 HANSEN, NICHOLAS ANDREW, GB
 (74) Agent: SIM & MCBURNEY

(54) Titre : CAPSULE DE DISTRIBUTION DE BOISSON ET PROCEDES D'UTILISATION ET DE FABRICATION
 (54) Title: BEVERAGE DELIVERY POD AND METHODS OF USE AND MANUFACTURE



(57) **Abrégé/Abstract:**

A pod containing one or more beverage ingredients is provided, where the pod comprises a generally rigid outer member (12) with an open top and an outlet opening in the bottom, with an internal filter (16) adjacent a bottom portion of the outer member, one or



(57) **Abrégé(suite)/Abstract(continued):**

more beverage ingredients disposed above the filter, and a lid (14) closing the open top. The outer member has an outer peripheral sidewall (20) defining the open top and extending downwardly from the open top toward the bottom portion and inwardly converging toward the outlet opening. The bottom portion of the sidewall defines a plurality of ribs (36) extending inwardly in the interior of the outer member toward the outlet opening. Beverage outlet flow paths are disposed between adjacent ribs and directed toward the outlet opening. The filter is supported above the outlet opening and the beverage outlet flow paths by the ribs.

(12) INTERNATIONAL APPLICATION PUBLISHED UNDER THE PATENT COOPERATION TREATY (PCT)

(19) World Intellectual Property
Organization
International Bureau(10) International Publication Number
WO 2012/122329 A1(43) International Publication Date
13 September 2012 (13.09.2012)

(51) International Patent Classification:

B65D 85/804 (2006.01)

(21) International Application Number:

PCT/US2012/028185

(22) International Filing Date:

8 March 2012 (08.03.2012)

(25) Filing Language:

English

(26) Publication Language:

English

(30) Priority Data:

61/450,548	8 March 2011 (08.03.2011)	US
1103953.4	8 March 2011 (08.03.2011)	GB

(71) Applicant (for all designated States except US): **KRAFT FOODS R & D, INC.** [US/US]; Three Lakes Drive, Northfield, Illinois 60093 (US).

(72) Inventor; and

(75) Inventor/Applicant (for US only): **HANSEN, Nicholas Andrew** [GB/GB]; Ruscote Avenue, Banbury Oxfordshire OX16 2QU (GB).(74) Agents: **KRATZ, Rudy** et al.; Fitch, Even, Tabin & Flannery, 120 S. LaSalle Street, Suite 1600, Chicago, Illinois 60603 (US).

(81) Designated States (unless otherwise indicated, for every kind of national protection available): AE, AG, AL, AM, AO, AT, AU, AZ, BA, BB, BG, BH, BR, BW, BY, BZ, CA, CH, CL, CN, CO, CR, CU, CZ, DE, DK, DM, DO, DZ, EC, EE, EG, ES, FI, GB, GD, GE, GH, GM, GT, HN, HR, HU, ID, IL, IN, IS, JP, KE, KG, KM, KN, KP, KR, KZ, LA, LC, LK, LR, LS, LT, LU, LY, MA, MD, ME, MG, MK, MN, MW, MX, MY, MZ, NA, NG, NI, NO, NZ, OM, PE, PG, PH, PL, PT, QA, RO, RS, RU, RW, SC, SD, SE, SG, SK, SL, SM, ST, SV, SY, TH, TJ, TM, TN, TR, TT, TZ, UA, UG, US, UZ, VC, VN, ZA, ZM, ZW.

[Continued on next page]

(54) Title: BEVERAGE DELIVERY POD AND METHODS OF USE AND MANUFACTURE

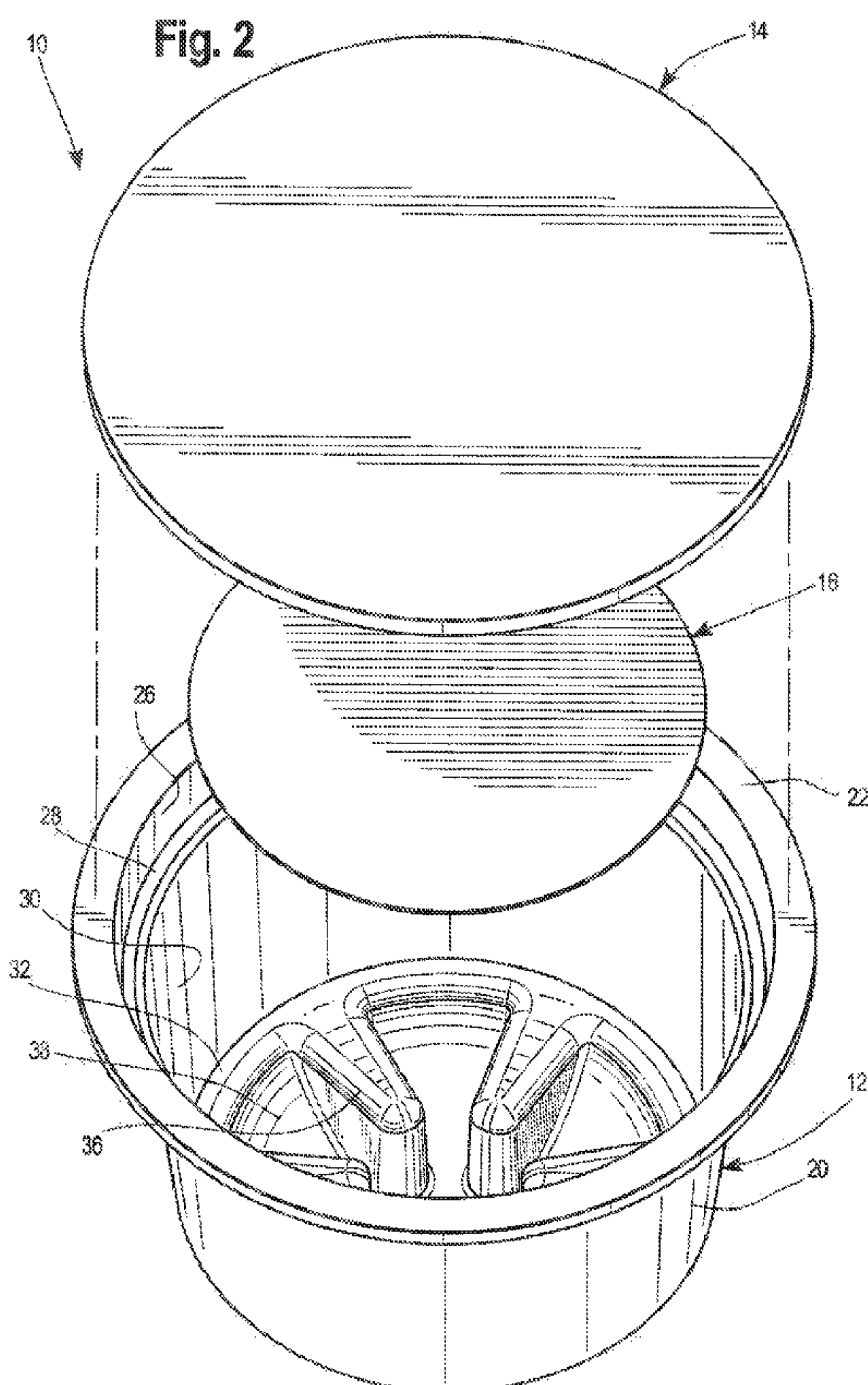

(57) Abstract: A pod containing one or more beverage ingredients is provided, where the pod comprises a generally rigid outer member (12) with an open top and an outlet opening in the bottom, with an internal filter (16) adjacent a bottom portion of the outer member, one or more beverage ingredients disposed above the filter, and a lid (14) closing the open top. The outer member has an outer peripheral sidewall (20) defining the open top and extending downwardly from the open top toward the bottom portion and inwardly converging toward the outlet opening. The bottom portion of the sidewall defines a plurality of ribs (36) extending inwardly in the interior of the outer member toward the outlet opening. Beverage outlet flow paths are disposed between adjacent ribs and directed toward the outlet opening. The filter is supported above the outlet opening and the beverage outlet flow paths by the ribs.

WO 2012/122329 A1



(84) Designated States (*unless otherwise indicated, for every kind of regional protection available*): ARIPO (BW, GH, GM, KE, LR, LS, MW, MZ, NA, RW, SD, SL, SZ, TZ, UG, ZM, ZW), Eurasian (AM, AZ, BY, KG, KZ, MD, RU, TJ, TM), European (AL, AT, BE, BG, CH, CY, CZ, DE, DK, EE, ES, FI, FR, GB, GR, HR, HU, IE, IS, IT, LT, LU, LV, MC, MK, MT, NL, NO, PL, PT, RO, RS,

SE, SI, SK, SM, TR), OAPI (BF, BJ, CF, CG, CI, CM, GA, GN, GQ, GW, ML, MR, NE, SN, TD, TG).

Published:

— *with international search report (Art. 21(3))*

BEVERAGE DELIVERY POD AND METHODS OF USE AND MANUFACTURE**Field**

[0001] A beverage delivery pod is described herein and, in particular, a sealed beverage delivery pod containing one or more ingredients for the preparation of beverages.

Background

[0002] Single serve beverage brewing systems can have a brewing machine configured to receive a filtered pod containing a single serving portion of one or more beverage ingredients, such as coffee or tea. The brewing machine can be configured in pass heated water through the pod to form and dispense a beverage therefrom. A machine can be configured to pierce the top of the pod to inject water into the pod, as well as to pierce the bottom of the pod to permit the beverage to exit the pod. The piercing of the pods for both the injection of water and the exiting of the beverage may not be desirable for all applications.

[0003] Beverage pods can be constructed from a variety of different materials and in a variety of different manners, not all of which lead to cost-effective manufacture and disposal and not all of which are suitable for use in different beverage brewing systems. Some beverage pods, for example, can require complex manipulations of internal elements during assembly. Other beverage pods can require complicated internal, injection molded components. Beverage pods are also known to be made with materials that can undesirably add to their cost.

Summary

[0004] A pod containing one or more beverage ingredients is provided, where the pod comprises a generally rigid outer member with an open top and an outlet opening in the bottom, with an internal filter adjacent a bottom portion of the outer member, one or more beverage ingredients disposed above the filter, and a lid closing the open top. The outer member has an outer peripheral sidewall, which can be generally annular, defining the open top and extending downwardly from the open top toward the bottom portion and inwardly converging toward the outlet opening. The bottom portion of the sidewall defines a plurality of ribs extending inwardly in the interior of the outer member toward the outlet opening. Beverage outlet flow paths are disposed between adjacent ribs and directed toward the outlet opening. The filter, which may be substantially planar, is supported above the outlet opening and the beverage outlet flow paths by the ribs.

[0005] In order to facilitate attachment of the filter, the sidewall includes an inward step about its periphery substantially coplanar with a top surface portion of the ribs to define an attachment surface to which the filter can be attached, such as by using an adhesive or by welding. While a large attachment surface can simplify attachment of the filter, if too large then more area of filter will be blocked, thereby decreasing the free flow area. In one aspect, the filter attached to the attachment surface has a ratio of free flow area to blocked flow area of between about 3:1 and 4:1, more preferably between about 3.2:1 and 3.7:1, and even more preferably about 3.4:1.

[0006] To increase the surface area of the filter, including the free flow area, the filter may be in a

conical, including truncated conical, configuration, whether facing upwardly or downwardly. This can be accomplished by configuring the top surface portions of the ribs to extend inwardly toward the outlet opening at an inclination such that the area of the attachment surface is larger than if the top surfaces of the ribs, and the filter thereon, were precisely coplanar.

[0007] The bottom portion of the sidewall can have a semi-circular or dome-shaped profile, which can be defined at least in part by curvilinear bottom walls of the outlet flow paths. The outlet flow paths can also be bounded by upstanding, interior sidewall segments disposed on opposite sides of each of the bottom walls. Those same sidewall segments can also form sidewall segments of the adjacent ribs.

[0008] The bottom portion of the sidewall, including if it is semi-circular or dome-shaped in profile, can be configured such that, in use, the pod is at least partially received in a brewing compartment of a beverage brewing device in a position for dispensing a beverage where the bottom portion of the sidewall is spaced from an upstanding piercing element of the brewing compartment. That is, the bottom portion of the sidewall does not have to be pierced to dispense a beverage. In one aspect, the height of the bottom portion is between about 20% and 30% of the total height of the pod, and more preferably about 25% of the total height of the pod. In another aspect, the outlet opening can be surrounded by a substantially planar segment of the sidewall. A ratio between the diameter of the substantially planar segment to a maximum diameter of sidewall adjacent the beverage ingredient compartment can be between about 1:3.7 and 1:4.7.

[0009] The materials used to form the beverage delivery pod can be selected to facilitate economical manufacture and/or recyclability. In one aspect, the lid can be formed on a non-metallic, multi-layer film. By omitting the metallic layer, the lid can more readily be removed from the outer member to empty remaining beverage ingredients after use and recycle the lid and/or the outer member. In another aspect, the outer member can be formed of a corn-based, biodegradable material. In yet another aspect, the lid and/or the outer member can be formed of materials lacking enhanced barrier properties. Instead, one or more pods can be provided within outer packaging, such as a flexible wrapper, which can provide greater barrier properties, as compared to the barrier properties of the lid and/or outer member of the pod.

[0010] A method of dispensing a beverage made from the beverage ingredients in any of the pods described herein is also provided. The method includes inserting the pod into a brew compartment of a beverage brewing device, forming an opening in the lid, and injecting an aqueous medium into the beverage ingredient compartment of the pod through the opening in the lid whereby the aqueous medium interacts with the one or more beverage ingredients to form a beverage. The method further includes filtering the beverage through the filter followed by dispensing the beverage from the beverage delivery pod through the outlet opening. The method includes optionally providing the pod with the outlet opening in an unblocked configuration prior to the step of inserting it into the brew compartment, such that a resultant beverage can exit the pod without requiring the bottom portion of the outer member to be pierced.

[0011] A method of manufacturing any of the beverage delivery pods described herein is also provided. The method can include providing the outer member, inserting the filter into the outer member, attaching the filter to the ribs in the bottom portion of the outer member and to at least substantially a peripheral portion of the sidewall surrounding the ribs, depositing the one or more beverage ingredients into the outer member above the filter, and attaching the lid to the outer member above the one or more beverage ingredients to close the beverage ingredient compartment.

Brief Description of the Drawings

[0012] FIGURE 1 is a side elevation view of a beverage delivery pod, showing an outer member with an attached lid;

[0013] FIGURE 2 is an exploded perspective view of the beverage delivery pod of FIGURE 1, showing the lid, an internal filter and the outer member, with the beverage ingredient omitted;

[0014] FIGURE 3 is a perspective view of the outer member of the beverage delivery pod of FIGURE 1, showing inwardly extending, raised ribs in the interior of a bottom portion of the outer member with outlet flow paths therebetween directed toward an outlet opening;

[0015] FIGURE 4 is a top plan view of the outer member of the beverage delivery pod of FIGURE 1;

[0016] FIGURE 5 is a cross-sectional elevation view of the beverage delivery pod of FIGURE 1, taken along line 5-5 as indicated on FIGURE 4 (with the lid, beverage ingredient, and filter omitted for clarity) and showing the lid, beverage ingredient, filter and curvilinear walls defining in part the outlet flow paths;

[0017] FIGURE 6 is a cross-sectional elevation view of the beverage delivery pod of FIGURE 1, taken along line 6-6 as indicated on FIGURE 4 (with the lid, beverage ingredient, and filter omitted for clarity) and showing the lid, beverage ingredient, filter and ribs; and

[0018] FIGURE 7 is a cross-section elevation view of the beverage delivery pod similar to that of FIGURE 5, but showing the pod disposed in a brew compartment of a beverage brewing device and with the bottom portion of the outer member being spaced from a bottom piercing element of the brew compartment.

Detailed Description

[0019] The beverage delivery pod 10 generally comprises outer member 12 for containing one or more beverage ingredients 18, a filter 16 supported in a bottom portion of the outer member 12, and a lid 14 closing a top portion of the outer member 12, as illustrated in whole or in part in FIGURES 1-7. In use, the beverage delivery pod 10 is configured to have its lid 14 pierced to form an opening through which an aqueous medium, typically water, is introduced. The one or more beverage ingredients can be, for example, roast and ground coffee or leaf tea. Other exemplary beverage ingredients include liquid coffee, chocolate or combinations thereof. The aqueous medium mixes with the one or more beverage ingredients 18 in the pod 10 to form a beverage which is passed through the filter 16 and dispensed through an outlet opening 34 disposed in the bottom portion of the outer member 12.

[0020] The beverage delivery pod 10 of the exemplary embodiment is configured to permit dispensing of the beverage without requiring the outer member 12 to be

pierced. Instead, the beverage is permitted flow out of the outlet opening 34 disposed in the bottom portion of the outer member 12, as depicted in FIGURE 7. The beverage delivery pod 10 of the exemplary embodiment is also configured to facilitate manufacturing, including providing the conical filter 16 which is supported in an elevated position above the outlet opening 34. The beverage delivery pod 10 of the exemplary embodiment is further configured to use reduced-cost components which can be readily recyclable.

[0021] Turning first to the configuration of the beverage delivery pod 10, the outer member 12 is generally in the shape of an annular cup, as depicted in FIGURES 1-4. The outer member 12 includes an outer sidewall 20 which forms the radially-outward boundary of the beverage delivery pod 10 as well as the bottom portion thereof. The sidewall includes a peripheral flange 22 extending radially outward from a top edge of an upper segment 26 of the sidewall 20, as depicted in FIGURE 1, and surrounding an open top of the pod 10. The peripheral flange 22 provides a surface against which the perimeter portion of the lid 14 is sealed. The diameter is reduced at an inwardly extending upper step 28 positioned at a lower edge of the upper segment 26 of the sidewall 20. A middle segment 30 of the sidewall 20 extends downwardly from a radially-inward edge of the upper step 28 to an outward edge of a lower step 32. The lower step 32 is at the transition of the sidewall 20 from the middle segment 30 to a lower, dome-shaped bottom portion 24 which represents the bottom of the outer member 12.

[0022] Both the upper segment 26, middle segment 30 and the bottom portion 24 are continuously tapered inwardly,

with the taper of the upper and middle segments 26 and 30 being substantially constant and the taper of the bottom portion 24 increasing, such that the diameter of the outer member 12 and thus the pod 10 decreases from top to bottom. Such a tapered configuration can facilitate withdrawal of the outer member 12 from a mold during formation, as well as facilitating insertion and location within a beverage machine. The steps 28 and 32 can function to increase the hoop strength of the outer member 12, thereby permitting the thickness and therefore the amount of material used to form the outer member 12 to be minimized. One or both of the steps 28 and 32 can also facilitate location and support during filling operations.

[0023] The bottom portion 24 of the sidewall 20 of the outer member 12 includes a plurality of raised, inwardly extending ribs 36, as depicted in FIGURES 2-4. The ribs 36 surround the outlet opening 34, as depicted in FIGURE 4. Disposed between the ribs 36 are flow channels which define at least in part outlet flow paths through which, in use, the beverage can pass through downstream of the filter 16 during flow toward the outlet opening 34. The ribs 36 and interspersed flow channels are with reference to the interior of the outer member 12. When viewed from the exterior, the ribs 36 appear to be grooves and the boundaries of the flow channels appear to be protruding elements separated by the grooves. Although six ribs 36 and flow channels are depicted in the figures, other numbers could be used, such as two or preferably three or more ribs and a corresponding number of flow channels.

[0024] The ribs 36 begin at an inward edge of the lower step 32 and are each defined by a pair of inwardly extending sidewall segments 40 and an inward front wall 42,

as depicted in FIGURE 4. Each of the ribs 38 also has a substantially planar top surface 44. The top surfaces 44 of the ribs 36 are substantially coplanar with the inner-facing surface of the lower step 32, such that the inner-facing surface of the lower step 32 forms a ring around the ribs 36, for purposes that will be described below.

[0025] The flow channels also begin at the inward edge of the lower step 32 and are each bounded on their bottom by a curvilinear bottom wall 38 and on their sides by the same sidewall segments 40 as define adjacent ribs 36. The curvilinear bottom walls 38 function to guide the beverage passing through the filter toward the outlet opening 34 in a generally smooth manner, e.g., free of obstructions or changes in direction of flow. The flow channels are each directed to a common space disposed about the outlet opening 34, where the flows can collide and combine to form one or more streams of beverage exiting the outlet opening 34, as illustrated in FIGURE 7. One of the curvilinear bottom walls 38 combine to provide the dome-shaped appearance of the bottom portion 24 of the sidewall 20 of the outer member 12, such as when viewed in side elevation, as depicted in FIGURE 1.

[0026] The inner-facing surface of the lower step 32 and the top surfaces 44 of the ribs 36 cooperate to form a substantially flat surface to which the filter 16 can be adhered. At least part of the substantially flat surface acts as an attachment surface, which is the portion to which the filter 16 is attached in a manner that impedes flow through the filter at the attachment surface. The adherence can be accomplished using an adhesive, welding or other suitable ways of attachment. The attachment to the inner-facing surface of the lower step 32 is preferably

substantially continuous, and more preferably completely continuous, so that most if not all of the beverage has to pass through the filter 16 before exiting through the outlet opening 34. The top surfaces 44 of the ribs 36 can help to support the filter 16 in an elevated position above the outlet opening 34 to provide a sufficiently dispersed area of the filter 16 such that the beverage passes through more of the unattached surface area of the filter 16 as opposed to being highly concentrated in a region immediately above or adjacent to the outlet opening 34, as could result if the filter were unsupported inwardly of the lower step 32. However, the attachment surface can block fluid flow through the immediately adjacent portion of the filter 16. This attachment surface is preferably minimized to a degree such that there still remains the vast majority of the surface area of the filter 16 free from attachment, i.e., unblocked by the attachment surface, while still providing for sufficient support to maintain the filter 16 in its elevated position during the pressurization and filtration during dispensing of a beverage. In a preferred embodiment, the filter 16 has a ratio of free flow area to blocked flow area of between about 3:1 and 4:1, more preferably between about 3.2:1 and 3.7:1, and even more preferably about 3.4:1. A larger unblocked surface area can result in reduced pressure requirements for forcing the beverage through the filter.

[0027] In order to increase the unblocked surface area of the filter 16, the filter 16 can be in a conical arrangement. That is, the center portion of the filter 16 is not precisely coplanar with the outer periphery thereof, but could be conical, including truncated conical, in shape. For example, the filter 16 can have an angle of

inclination toward its center portion of between about 10 and 15 or 20 degrees, more preferably between about 20 and 40 degrees, and, in an exemplary embodiment, even more preferably about 30 degrees. The filter 16 could have a height less than its diameter. For instance, an angle of inclination of 30 degrees in a filter having a diameter of 37 mm can increase the total area of the filter 16 from 1007 mm² if precisely planar to 1165 mm². While the conical shape can either be directed upwardly or downwardly to increase the surface area, it is preferred that the conical shape of the filter 16 be directed downwardly toward the outlet opening 34. The filter could alternatively be substantially planar.

[0028] In order to achieve the conical shape of the filter 16, the top surfaces 44 of the ribs 36 can be slightly inclined, either upwardly or downwardly, at the same or generally the same angle of inclination as is desired for the filter 16. Furthermore, the top surfaces 44 of the ribs 36 can be inwardly tapered or narrowed such that there is lesser support or blocked surface area of the filter 16 toward its center portion, which is where the beverage will tend to exit.

[0029] Turning now to details of the material and construction of the components of the beverage delivery pod 10, the outer member 12 in the exemplary embodiment is of thin walled, generally rigid construction. By generally rigid, what is meant is that the structure has the ability to generally retain its respective shape during normal handling, and if deformed will tend to return toward its original shape. The outer member 12 is preferably formed of a biodegradable polymer material, such as a corn-based material. Suitable materials include degradable

polyethylene (for example, SPITEK supplied by Symphony Environmental, Borehamwood, United Kingdom), biodegradable polyester amide (for example, BAK 1095 supplied by Symphony Environmental), poly lactic acids (PLA supplied by Cargill, Minn., USA), starch-based polymers, cellulose derivatives and polypeptides.

[0030] The filter 16 is preferably made from a material with a high wet strength, for example a non-woven fibre material of polyester. Other materials which may be used include a water-impermeable cellulosic material, such as a cellulosic material comprising woven paper fibres. The woven paper fibres may be admixed with fibres of polypropylene, polyvinyl chloride and/or polyethylene. The incorporation of these plastic materials into the cellulosic material renders the cellulosic material heat-sealable to the surface portions 44 of the ribs 36 and the inner-facing surface of the lower step 32. The filter 16 may also be treated or coated with a material which is activated by heat and/or pressure so that it can be sealed to the attachment surfaces.

[0031] The lid 14 is preferably a multi-layer film, made from one or more polypropylene (PP) or filled polypropylene layers and a polyethylene terephthalate (PET) layer. In one example, the lid 14 can have the following layers: PP (about 25 microns), filled PP (about 60 microns), PP (about 25 microns) and PET (about 23 microns). Preferably, though not necessarily, the lid 14 is free of metallic layers, such as an aluminum foil layer. This can permit the lid 14 to be more readily removed from attachment to the flange 22 of the sidewall 20 of the outer member 12 without leaving metallic remnants behind. This can permit the lid 14 to be removed from the outer member 12 after use, the contents

dumped or otherwise removed, and the outer member 12 ready to be recycled.

[0032] Both the lid 14 and the outer member 12 can lack traditional barrier layers. Elimination of the barrier layers can reduce the costs of the components. In order to provide the barrier properties for suitable shelf life of the beverage delivery pods 10, outer packaging for one or groups of two or more of the pods 10 can be provided, such as an outer wrapper, which may be in the form of a flow wrapped film.

[0033] The beverage delivery pod 10 can be configured for use in a beverage brewing device having a brew compartment 100 defined by an outer wall 104, as illustrated in FIGURE 7. The peripheral flange 22 of the outer member 12 of the pod 10 can be supported on an upper part 102 of the outer wall 104 of the brew compartment 100. The pod 10 can be configured such that it is not pierced by a bottom piercing member 110 of a bottom wall 106 of the compartment 100 when fully inserted to a degree sufficient for brewing. The outlet opening 34 of the bottom part 24 of the sidewall 20 of the outer member 12 is preferably open, e.g., it does not require piercing. While it can be completely open, it also can be initially closed, such as with a label that can be removed prior to insertion in the brew compartment 100 or a dissolvable plug disposed in the pod 10 to block the outlet opening 34 until dissolved by the dispensing beverage, heat or other present, non-mechanical factors.

[0034] A method of dispensing a beverage made from the beverage ingredients in any of the pods described herein is also provided. The method includes inserting the pod 10 into a brew compartment 100 of a beverage brewing device,

forming an opening in the lid 14, such as by using an inlet piercer 112, and injecting an aqueous medium into the beverage ingredient compartment of the pod 10 through the opening in the lid 14 and the inlet piercer 112, whereby the aqueous medium interacts with the one or more beverage ingredients 18 to form a beverage. The method further includes filtering the beverage through the filter 16 followed by dispensing the beverage from the beverage delivery pod 16 through the outlet opening 34 and into the brew compartment 100, and from the brew compartment 100 through an outlet 108 thereof. The method includes optionally providing the pod 10 with the outlet opening 34 in an unblocked configuration prior to the step of inserting it into the brew compartment 100, such that a resultant beverage can exit the pod 10 without requiring the bottom portion of the outer member 12 to be pierced, such as by a piercer 110 associated with the bottom 106 of the brew compartment 100.

[0035] A method of manufacturing any of the beverage delivery pods 10 described herein is also provided. The method can include providing the outer member 12, inserting the filter 16 into the outer member 12, attaching the filter 16 to the ribs 36 in the bottom portion of the outer member and to at least substantially a peripheral portion of the inner-facing surface of the lower step 32 surrounding the ribs 36, depositing the one or more beverage ingredients 18 into the outer member 12 above the filter 16, and attaching the lid 14 to the outer member 12 above the one or more beverage ingredients 18 to close the beverage ingredient compartment.

[0036] From the foregoing, it will be appreciated that beverage delivery pods, methods of use and methods of

manufacture are provided. However, numerous modifications and variations could be made thereto by those skilled in the art without departing from the scope of the description herein and as set forth in the claims.

Claims:

1. A pod containing one or more beverage ingredients, the pod comprising:

a generally rigid outer member having an outer peripheral sidewall defining an open top and extending downwardly from the open top toward a bottom portion and inwardly converging toward an outlet opening, the bottom portion of the sidewall defining a plurality of ribs extending inwardly in the interior of the outer member toward the outlet opening, and beverage outlet flow paths disposed between adjacent ribs and directed toward the outlet opening;

a filter supported above the outlet opening and the beverage outlet flow paths by the plurality of ribs;

a lid attached to the sidewall of the outer member to close the open top to form a beverage ingredient compartment bounded in part by the lid and the filter, the lid being pierceable to accommodate an inflow of an aqueous medium into the beverage ingredient compartment; and

one or more beverage ingredients disposed in the beverage ingredient compartment.

2. A pod as claimed in claim 1, wherein the sidewall includes an inward step about its periphery substantially coplanar with a top surface portion of the ribs to define an attachment surface to which the filter is attached.

3. A pod as claimed in claim 2, wherein the filter attached to the attachment surface has a ratio of free flow area to blocked flow area of between about 3:1 and 4:1,

more preferably between about 3.2:1 and 3.7:1, and even more preferably about 3.4:1.

4. A pod as claimed in any of claims 2 and 3, wherein the top surface portions of the ribs extend inwardly toward the outlet opening at a slight inclination such that the area of the attachment surface is larger than if the top surface of the ribs were precisely coplanar.

5. A pod as claimed in any of claims 1-4, wherein the bottom portion of the sidewall has a dome-shaped profile.

6. A pod as claimed in claim 5, wherein the beverage outlet flow paths are each defined in part by a curvilinear bottom wall and upstanding, interior sidewall segments at opposite sides of the bottom wall, the sidewall segments also forming sidewall segments of the adjacent ribs.

7. The pod as claimed in claim 6, wherein the dome-shaped profile is defined by the curvilinear bottom walls.

8. The pod as claimed in any of claims 5-7, wherein the dome-shaped profile has a height of between about 20% and 30% of the total height of the pod, and more preferably about 25% of the total height of the pod.

9. The pod as claimed in any of claims 1-8, wherein the bottom portion of the sidewall is configured such that, in use, the pod is at least partially received in a brewing compartment of a beverage brewing device in a position for dispensing a beverage where the bottom portion of the

sidewall is spaced from an upstanding piercing element of the brewing compartment.

10. The pod as claimed in any of claims 1-9, wherein the sidewall is annular and the outlet opening is surrounded by a substantially planar segment of the sidewall, a ratio between the diameter of the substantially planar segment to a maximum diameter of sidewall adjacent the beverage ingredient compartment being between about 1:3.7 and 1:4.7.

11. The pod as claimed in any of claims 1-10, wherein the lid is a non-metallic, multi-layer film.

12. The pod as claimed in any of claim 1-11, wherein the outer member is formed of a corn-based, biodegradable material.

13. The pod as claimed in any of claims 1-12, in combination with an outer flexible wrapper providing greater barrier properties as compared to any barrier properties of the lid and/or outer member of the pod.

14. A method of dispensing a beverage made from the beverage ingredients in the pod of any of claims 1-13, the method comprising:

providing the pod with the outlet opening in an unblocked configuration;

inserting the pod into a brew compartment of a beverage brewing device;

forming an opening in the lid;

injecting an aqueous medium into the beverage ingredient compartment of the pod through the opening in the lid whereby the aqueous medium interacts with the one or more beverage ingredients to form a beverage;

filtering the beverage through the filter; and

dispensing the beverage from the beverage delivery pod through the outlet opening.

15. A method of manufacturing the beverage pod of any of claims 1-13, the method comprising:

providing the outer member;

inserting the filter into the outer member;

attaching the filter to the ribs in the bottom portion of the outer member and to at least substantially a peripheral portion of the sidewall surrounding the ribs;

depositing the one or more beverage ingredients into the outer member above the filter; and

attaching the lid to the outer member above the one or more beverage ingredients to close the beverage ingredient compartment.

Fig. 1

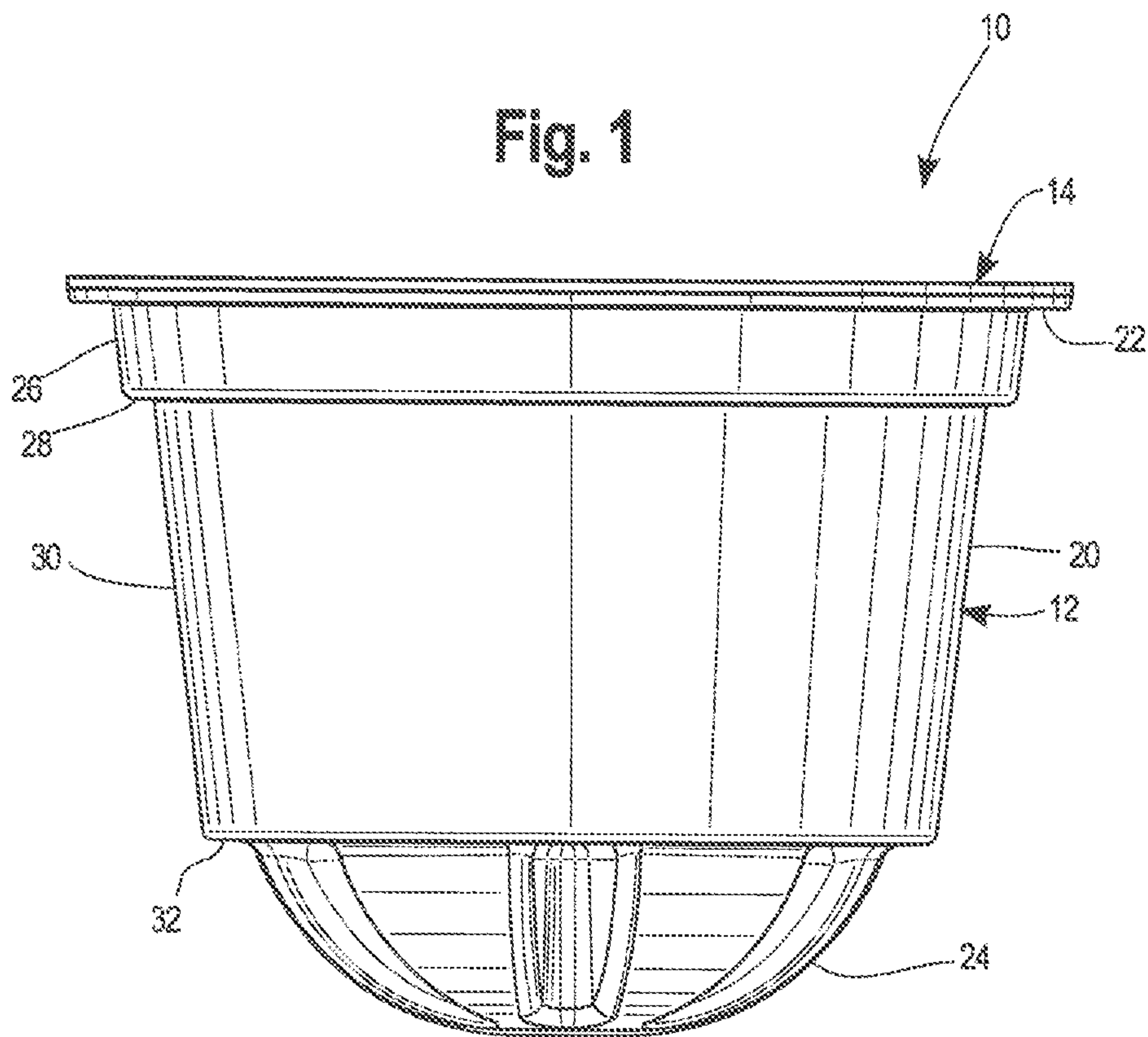

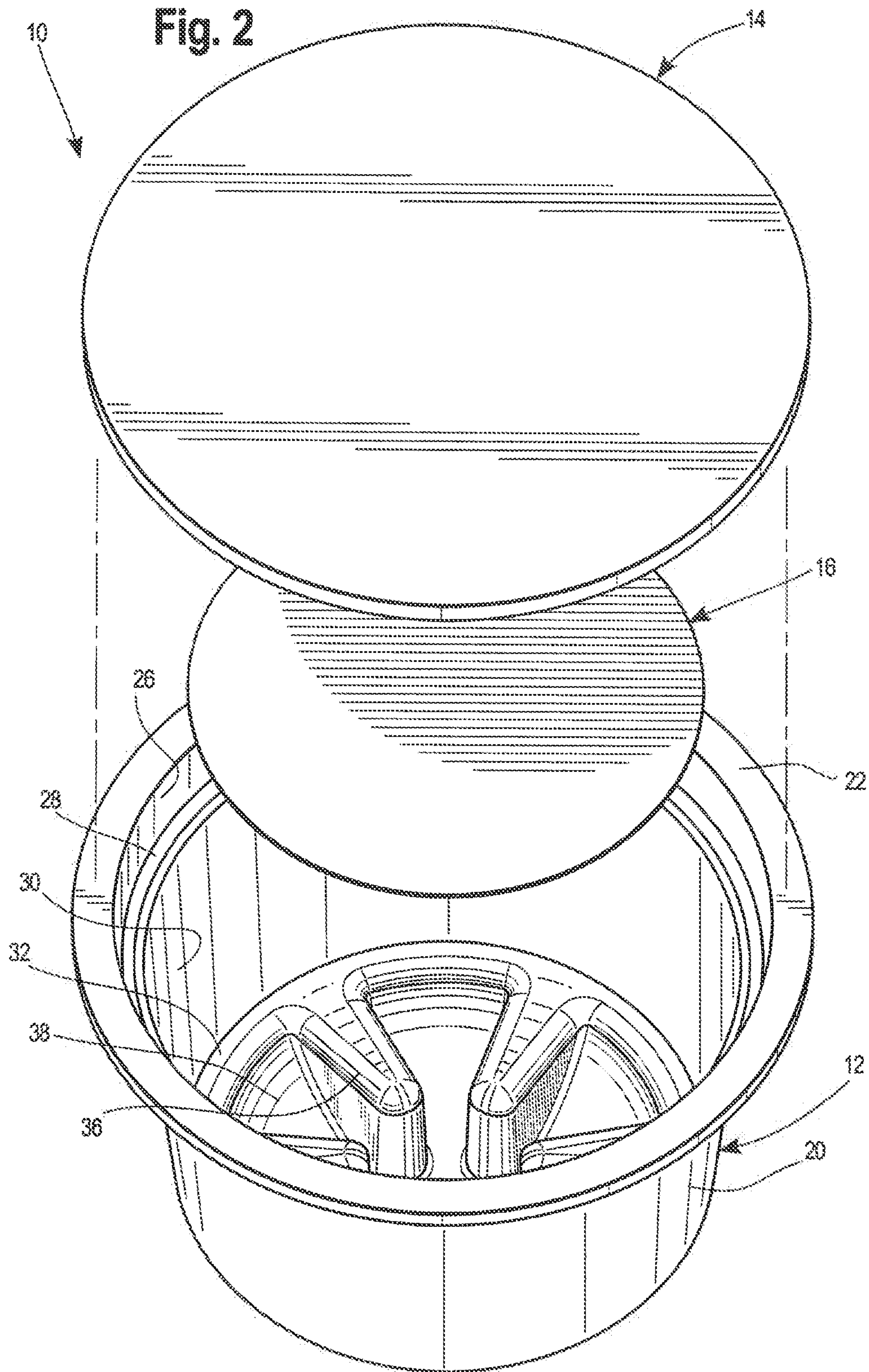

Fig. 3

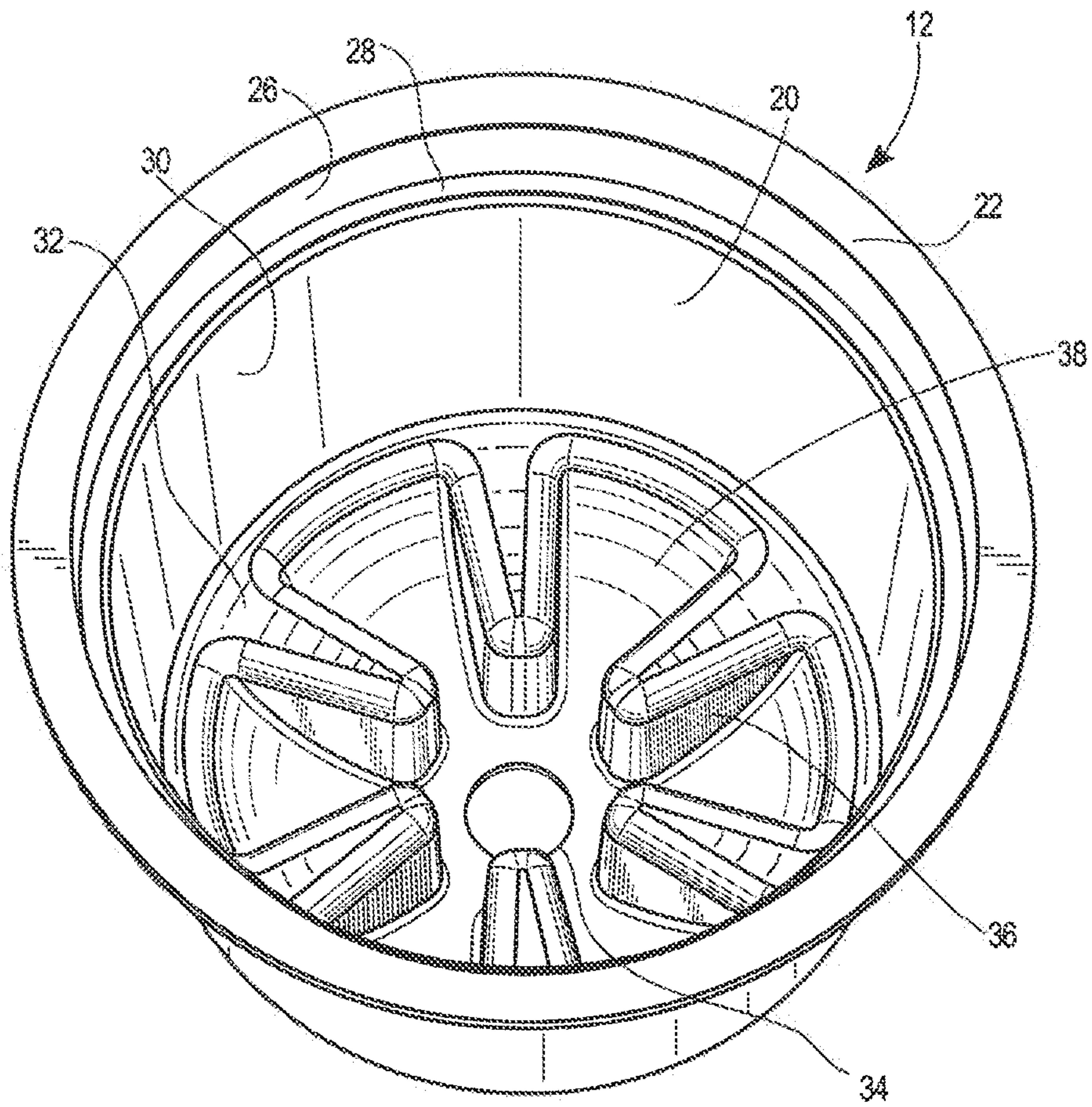

Fig. 4

4/5

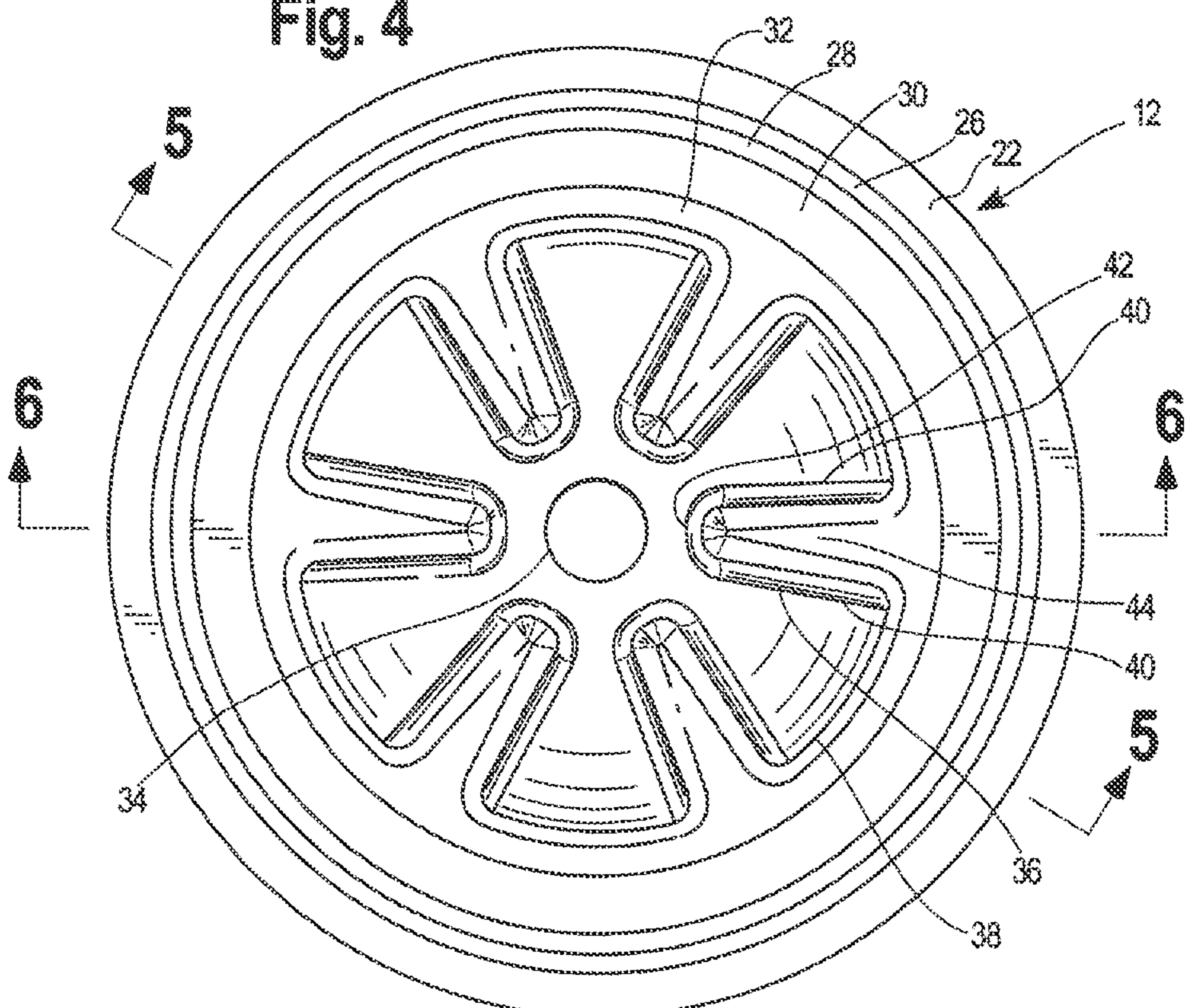

Fig. 5

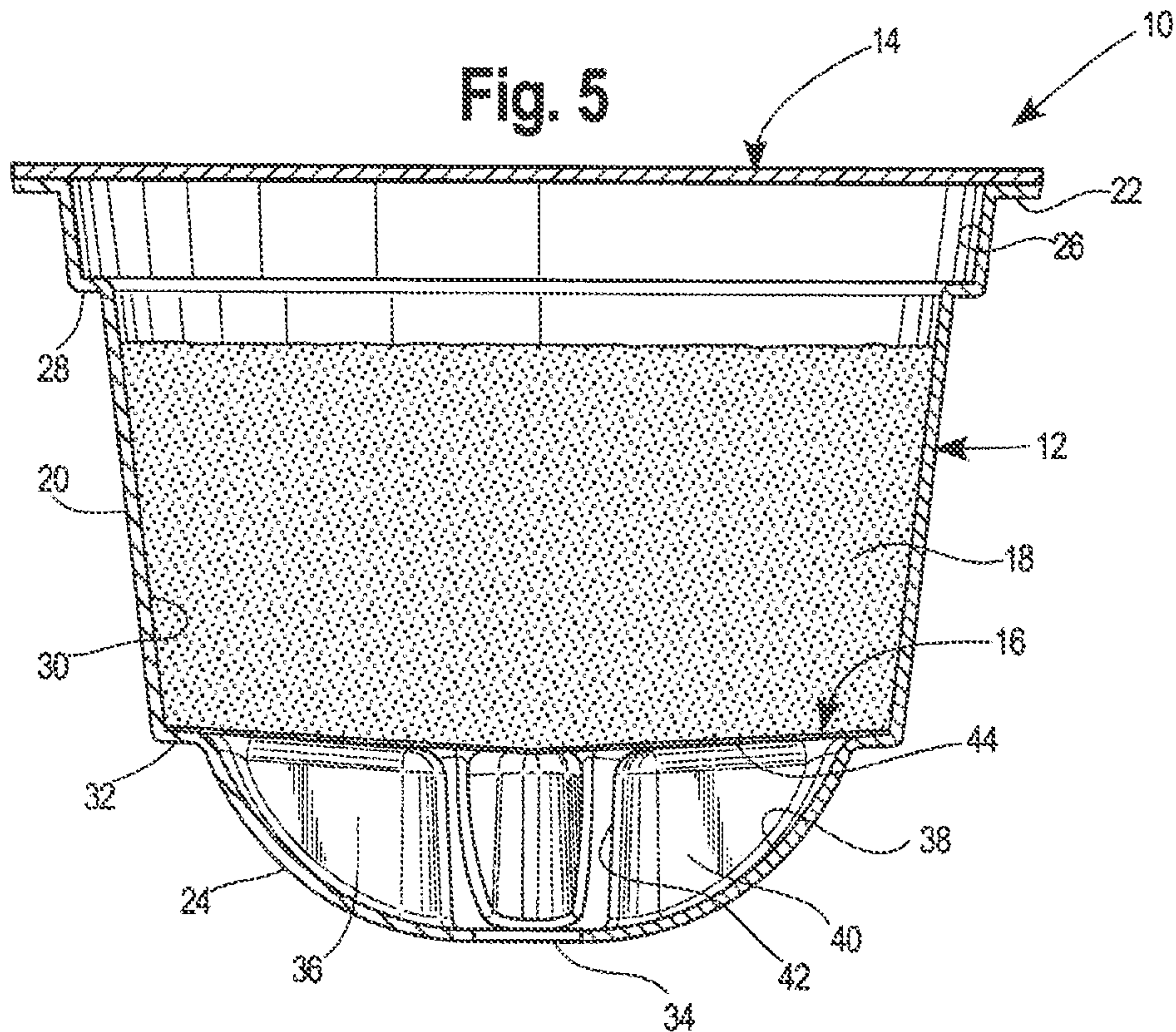

Fig. 6

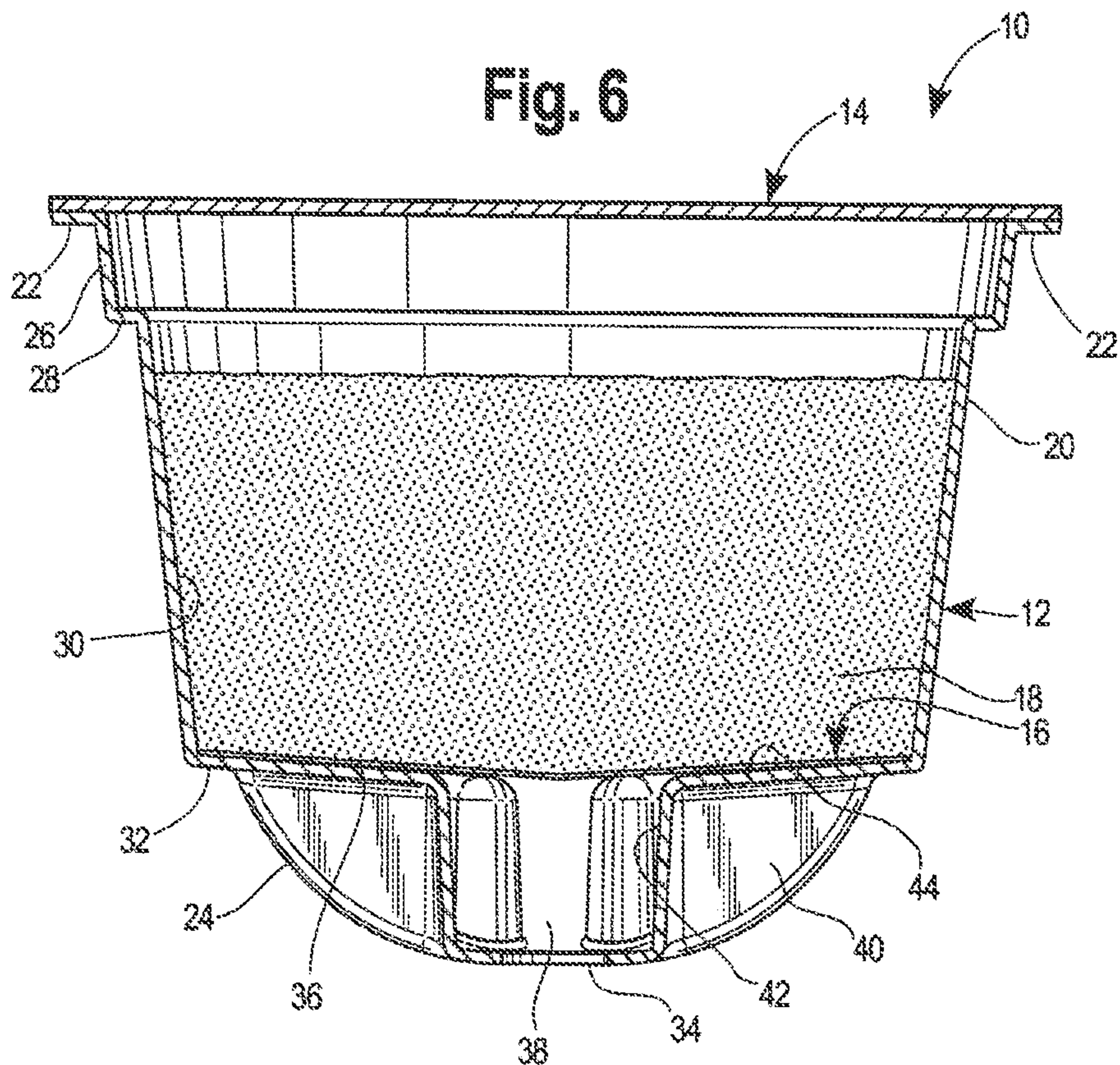

Fig. 7

