



- (51) International Patent Classification:  
*F24F 7/007* (2006.01) *E06B 7/02* (2006.01)
- (21) International Application Number:  
PCT/FI2014/050599
- (22) International Filing Date:  
29 July 2014 (29.07.2014)
- (25) Filing Language: Finnish
- (26) Publication Language: English
- (30) Priority Data:  
20140023 30 January 2014 (30.01.2014) FI
- (72) Inventor; and  
(71) Applicant : HAVIA, Kyösti [FI/FI]; Koiranpolku 44, FI-34110 Lakiala (FI).
- (74) Agent: KANGASMÄKI, Reijo; Finnish Patent Consulting FPC, PL 25, FI-33401 Tampere (FI).
- (81) Designated States (*unless otherwise indicated, for every kind of national protection available*): AE, AG, AL, AM, AO, AT, AU, AZ, BA, BB, BG, BH, BN, BR, BW, BY,

BZ, CA, CH, CL, CN, CO, CR, CU, CZ, DE, DK, DM, DO, DZ, EC, EE, EG, ES, FI, GB, GD, GE, GH, GM, GT, HN, HR, HU, ID, IL, IN, IR, IS, JP, KE, KG, KN, KP, KR, KZ, LA, LC, LK, LR, LS, LT, LU, LY, MA, MD, ME, MG, MK, MN, MW, MX, MY, MZ, NA, NG, NI, NO, NZ, OM, PA, PE, PG, PH, PL, PT, QA, RO, RS, RU, RW, SA, SC, SD, SE, SG, SK, SL, SM, ST, SV, SY, TH, TJ, TM, TN, TR, TT, TZ, UA, UG, US, UZ, VC, VN, ZA, ZM, ZW.

- (84) Designated States (*unless otherwise indicated, for every kind of regional protection available*): ARIPO (BW, GH, GM, KE, LR, LS, MW, MZ, NA, RW, SD, SL, SZ, TZ, UG, ZM, ZW), Eurasian (AM, AZ, BY, KG, KZ, RU, TJ, TM), European (AL, AT, BE, BG, CH, CY, CZ, DE, DK, EE, ES, FI, FR, GB, GR, HR, HU, IE, IS, IT, LT, LU, LV, MC, MK, MT, NL, NO, PL, PT, RO, RS, SE, SI, SK, SM, TR), OAPI (BF, BJ, CF, CG, CI, CM, GA, GN, GQ, GW, KM, ML, MR, NE, SN, TD, TG).

**Published:**

— with international search report (Art. 21(3))

(54) Title: SUPPLY AIR APPARATUS

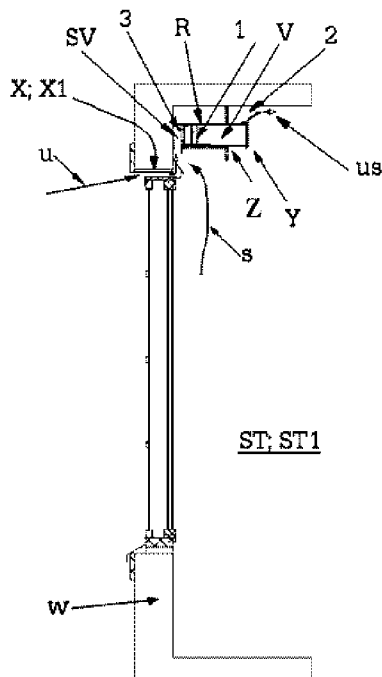

**FIG. 3**

(57) Abstract: The invention relates to a supply air apparatus, which is meant for producing outdoor air into an indoor space assisted by an auxiliary powered blower arrangement (1) by simultaneously mixing the outdoor air (u) to be brought into the indoor space with air from the indoor space (s). The supply air apparatus comprises in connection with an outdoor air flow way that exists in a structure (W) in a building between the indoor space and outside air a flow space (V) along with its flow connections for outdoor and indoor air for mixing the above with each other, the blower arrangement (1), such as one or more, advantageously on axial principle operated, blowers, and a blow flow arrangement (2) for leading a mixed flow of air (us) into the indoor space in the building. The supply air apparatus comprises in connection with a supply air device (X), such as a replacement air valve or like, in an outer wall of the building a built-in air distribution device (Y), which comprises: a boxstructured frame (R); an internal flow space (V) in the frame; an inflow arrangement (SV) of outdoor and indoor air that joins with the flow space and opens into an internal space (ST) in the building; the blower arrangement (1), such as one or several parallelly coupled device blowers or like; and a blow flow arrangement (2) leading the mixed air (us) into the indoor space.

## Supply air apparatus

The invention relates to a supply air apparatus according to the preamble of the independent claim related thereto, which supply air apparatus is meant especially for producing outdoor air into an indoor space assisted by an auxiliary powered, such as electrical, blower arrangement by simultaneously mixing the outdoor air to be brought into the indoor space with air from the indoor space.

Especially in underpressurized air conditioning systems the ventilation is based on underpressurizing, my means of which air is sucked in. Unless there are controlled pathways for replacement air, air tends to drift inside a building through all possible routes. In order to control the replacement air flows, there are in practice first of all passive that is without a blower naturally operating replacement air valves that have typically both mechanical adjustment arrangements for adjusting the amount of replacement air and filter arrangements in order to filter replacement air being fed indoors and to dampen the noise coming from outside. On the other hand, there are in practice also active that is blower operated replacement air valves and furthermore also replacement air valves provided with heating arrangements, with which the production of replacement air may be adjusted e.g. with adjustment mechanisms or by adjusting the speed of rotation of the blower.

One problem in producing replacement air is the movement of the cold outdoor air, being fed indoors, which causes a so called feeling of draft. The optimal functioning of an air replacement valve is based on a flow of warm indoor air passing upwards, which lifts the cold replacement air to go upwards along the inner surface of the ceiling. When such a flow slows down it gets thus warmer by getting mixed with the warm air

close to the ceiling, causing thus not any feeling of draft to be noticed in the living space of the apartment. This is why the replacement air valves are usually installed above radiators.

5

Nowadays energy efficiency of buildings has been improved and radiators have been exchanged e.g. into low-heat radiators or the heating has been switched to underfloor heating, due to which the air flow passing upwards along the walls has diminished and is thus not able to eliminate the feeling of draft on its own. On the other hand, in traditional construction technique the flow of replacement air often takes place in a decentralized manner e.g. through window gaps, whereby the speed of replacement air flow is relatively slow. In these types of cases, e.g. in connection with window renovation according to today's practice, windows have either been tightened and the apartments have been provided with separate replacement air valves or the original windows have been replaced with new windows having replacement air valves, after which the flow of replacement air into the apartment takes place at a higher speed in a spotlike manner. Actually the speed of replacement air flow rises even more, because in traditional renovation usually all windows are tightened and only some are provided with replacement air valves. Due to the feeling of draft, the replacement air valves are often closed during a heating season, which disrupts the ventilation. However, from the point of view of the functioning of the ventilation, it is important that feeding of replacement air occurs as planned regardless of outside temperature.

Furthermore, especially when placing the window valves in spaces that have e.g. curtain boxes, the natural flow of replacement air is blocked, which is why it may flow down e.g. along the window surface causing both a feeling of draft and the moistening/frosting of the

35

inner surface of the window, which also often leads to the closure of the replacement air valves. E.g. in an apartment building, when one or more residents close their replacement air valves and the constant-speed exhaust air volume does not diminish, a higher under-pressure is caused in other apartments and thus also a stronger feeling of draft, which brings about a need for other residents to also close the replacement air valves.

Preventing the free and controlled feed flow of replacement air causes a distortion for the pathways of replacement air in the buildings, in which case air enters through structures, hallways and even through the sewer system. This causes unclean indoor air and strains the structures. Symptoms of these types of problems are e.g. smells in the apartments that are drifted from e.g. neighbours, the hallway, the sewer etc. and sewer clogs. Thus, e.g. in ground floor buildings, such as in terraced houses or single-family houses and in the lower floors in apartment buildings, but the same way also in higher floors through e.g. elevator shafts and other vertical shafts, the closure of the replacement air valves causes the replacement air to pass through the ground and the structures. In this case, e.g. natural gases, such as e.g. radon, are basically being sucked into the apartment, which as such is a significant health risk, controlling of which requires measuring actions and based on which, when the threshold values are exceeded, renovating actions, such as assembling a radon well etc.

Especially in order to control the feeding of outdoor air to be fed into a building's indoor space, a supply air apparatus is previously known from e.g. patent publication GB 2260807, which supply air apparatus comprises a flow space with flow connections in connection with an outdoor air flow way in between an indoor

space of a building and outdoor air in order to mix outdoor air and indoor air with each other, a blower arrangement, such as a blower functioning on axial principle, and a blow flow arrangement in order to lead  
5 the mixed air inside the building.

With a solution described above it is possible to carry out the feeding of outdoor air into an indoor space by mixing indoor air, being produced from an apartment by  
10 an indoor air suction blower, with outdoor air, being fed into a suction channel by a blower, by feeding the mixed air to pass near the ceiling of the room guided by a lower guide. In this solution, the volume flow of the mixed air flow being blown into the apartment is to  
15 be regulated by adjusting the functioning of the blower, whereby the air being blown into the room is also, if needed, heated by auxiliary heaters existing near the ceiling. In addition, the air blower that circulates the indoor air is being guided according to outdoor  
20 air temperature in a way that its capacity is highest when outdoor air temperature is low and lowest when outdoor air temperature is high.

A disadvantage of the above mentioned solution is the  
25 large amount of apparatuses that is the blowers for both outside and inside air used therein, in addition to which the principle according to the solution may not be used as such in connection with existing replacement air valves that usually have already at least a  
30 mechanical adjustment arrangement in order to adjust the amount of outdoor air to be brought through the replacement air valve into the apartment.

The supply air apparatus according to the present in-  
35 vention is aimed to achieve a decisive improvement in the problems described above and thus to raise substantially the level of prior art. In order to achieve this aim, the supply air apparatus according to the inventi-

on is primarily characterized by what has been presented in the characterizing part of the independent claim related thereto.

5 As the most important advantages of the supply air apparatus according to the invention may be mentioned simplicity and efficiency of utilization and constructions related thereto, which, through eliminating the feeling of draft, enable the functioning of replacement  
10 air valves in apartments to be made more efficient by lowering the need for underpressurizing by helping the passage of replacement air. Thus, there is no need for closing the replacement air valves as the ventilation of the indoor air in the apartment takes place optimal-  
15 ly thanks to the air from the replacement air valves occurring as an overhead flow in the living space of the apartment. By virtue of the invention, the "climate" of the apartment improves significantly as the feeding of the replacing outdoor air occurs in a way that the replacement air being brought into the apart-  
20 ment heats up at the ceiling of the apartment before drifting downward, which eliminates the feeling of draft from getting born.

25 As an advantageous embodiment, in the blower arrangement of the supply air apparatus according to the invention it is possible to utilize an extra-low voltage, typically e.g. at 5-24 V voltage, operated device blower, the power supply and control of which may be carried out a lot simpler than on mains current operated  
30 devices and in a more safe way with respect to both its assembly and use.

35 The supply air apparatus according to the invention may furthermore advantageously be carried out e.g. by installing the air distribution device according to the invention above an existing replacement air valve in a wall so that the inflow arrangement of the air distri-

5           bution device opening into an indoor space of a building "sucks" both outdoor air being led through the replacement air valve and warm indoor air, and forwards the mixed air flow further with one or more parallel device blowers to take place essentially close to the ceiling through an overhead guide in the air distribution device without the risk of drifting thereof e.g. down along a window surface.

10           The supply air apparatus according to the invention may as an alternative solution be carried out also by an air distribution device, being in an integrated manner in connection with a window so that it is placed in the space between overlapping window structures, wherein  
15           its outdoor air production is advantageously arranged by outdoor air, being led in e.g. through ventilation holes in the outer window structure of the window. The controlling of the supply air apparatus according to the invention may furthermore be carried out the simplest way by controlling the functioning of its blower arrangement that is its speed of rotation  
20           electronically e.g. wirelessly.

25           With the supply air apparatus according to the invention it is thus possible to both improve the ventilation of existing buildings by improving the functioning of existing replacement air valves and make possible proper production of replacement air from the very beginning in the new building construction without the need  
30           for the residents to adjust the replacement air valves due to the feeling of draft. In addition, in the renovation construction it is possible to replace windows in poor condition with tightened ones, provided with replacement air valves for producing desired replacement air. Thanks to a properly functioning ventilation,  
35           in addition to the feeling of draft, also those very common problems due to mold and other the like problems caused by badly functioning ventilation may be avoided.

In the following description the invention is being described in detail with reference to the enclosed drawings, in which

5        in figures 1a-1e  
         are shown a front view, a side view, a cross-sectional side view, an overhead view and diagonally from above shown perspective view of an advantageous air distribution device according to a first alternative of the supply air apparatus according to the invention,

10                    in figures 2a-2b  
15                    are shown respective views as in figures 1a, 1b, 1d and 1e of an alternative implementation with respect to the air distribution device shown in figures 1a-1e,

20        in figure 3  
         is shown a side view regarding the placement of an air distribution device, implemented according to the first alternative, above a replacement air valve in connection with a curtain box,

25                    in figure 4  
         is shown an alternative implementation with respect to figure 3, in which the air distribution device according to the first alternative is placed in the wall above a replacement air valve close to the ceiling, and

30                    in figures 5a and 5b  
35                    are shown as an exemplary manner first of all a side view of an implementation of the air distribution device according to a second

alternative of the supply air apparatus and secondly an enlarged detail from the placement point of the air distribution device.

5 The invention relates to a supply air apparatus, which is meant for producing outdoor air into an indoor space assisted by an auxiliary powered, advantageously electrical, blower arrangement 1 by simultaneously mixing the outdoor air  $u$  to be brought into the indoor space  
10 with air from the indoor space  $s$ . The supply air apparatus comprises in connection with an outdoor air flow way that exists in a structure  $W$  in a building between the indoor space and outdoor air a flow space  $V$  along with its flow connections for outdoor air and indoor  
15 air for mixing the above with each other, the blower arrangement 1, such as one or more, advantageously on axial principle operated, blowers, and a blow flow arrangement 2 for leading a mixed flow of air  $us$  into the indoor space in the building. The supply air apparatus comprises in connection with a supply air device  
20  $X$ , such as a replacement air valve or like, in an outer wall of the building a built-in air distribution device  $Y$ , which comprises: a box-structured frame  $R$ ; an internal flow space  $V$  in the frame; an inflow arrangement  $SV$  of outdoor and indoor air that joins with the flow  
25 space and opens into an internal space  $ST$  in the building; the blower arrangement 1, such as one or several parallelly coupled device blowers or like; and the blow flow arrangement 2 that leads the mixed air  $us$  into the  
30 indoor space.

As an advantageous embodiment of a first alternative of the air supply apparatus according to the invention as shown e.g. in figures 1a-1e or 2a-2d, the air distribution device  $Y$  is arranged on the principle as shown  
35 e.g. in figures 3 and 4 in the indoor space  $ST1$  in the building on an inner surface of an outer wall, such as in a wall or a ceiling, above a supply air device  $X$ ,

such as replacement air valve X1 in a window or a like, existing in an outer wall W of the building.

5 As an advantageous embodiment of the second alternative of the supply air apparatus according to the invention, the air distribution device Y is arranged on the principle as shown e.g. in figures 5a, 5b in a space ST2 between window structures i1, i2 in a window existing in an outer wall W of the building.

10 Thus, as a furthermore advantageous embodiment of the supply air apparatus according to the invention, feeding of the outdoor air into the air distribution device Y is arranged by outdoor air u that is led into the space ST2 between the window structures i1, i2 in the window through flow ways iR existing in connection with the outer window structure i1 of the window, such as through ventilation openings at a lower edge thereof.

15 20 In this context, as a further advantageous embodiment of the supply air apparatus according to the invention, the inflow arrangement SV1 of indoor air comprises a flow way leading from the indoor space ST to the frame R for leading of indoor air of the building to the flow space R, V in the frame and the inflow arrangement SV2 of outdoor air comprising a flow way that is open from the frame R to the space ST2 between the window structures.

25 30 In this context, as a further advantageous embodiment, the blow flow arrangement 2 comprises a flow way 2a that leads from the frame R into the indoor space ST in the building for leading the mixed air us into the indoor space ST1.

35 As a further advantageous embodiment of the first alternative of the supply air apparatus according to the invention, the inflow arrangement SV for outdoor and

indoor air and/or the blow flow arrangement 2 of the air distribution device Y is/are arranged on the principle as shown in figures 1d, 1e and 2c, 2d when viewed in a horizontal plane to be directed in more than one direction. Differing from what is shown in figures 1a-1e, in the implementation shown in figures 2a-2d, there is in an arched manner uniformly continuing hole for the inflow of indoor and outdoor air and an outflow hole 2 for mixed air.

10

As a further advantageous embodiment of the supply air apparatus according to the first alternative, an end II on the side of the output end of the air distribution device's frame R is arranged e.g. in a continuously arched manner convex towards the indoor space ST1 in the building.

15

Furthermore as an advantageous embodiment of the supply air apparatus according to the invention with reference to figures 1a-1e and 2a-2d, the inflow arrangement SV and/or the blow flow arrangement 2 of the air distribution device comprise/comprises in one or more parts, when viewed from the side, in an inclined position from the frame R outwards directed guide surfaces OP for guiding the air flows in a direction of height.

20

As it is possible to implement the embodiment shown in figure 4 according to e.g. embodiments shown in figures 1 and 2, the air distribution device Y in figure 3 differs partly from the type of embodiment shown in figures 1 and 2, wherein the length of the body of the air distribution device is arranged adjustable advantageously e.g. on telescope-principle in order to fit the device in different kinds of widow box structures Z.

25

As a further advantageous embodiment of the supply air apparatus according to the invention, the air distribution device comprises with cleanable and/or replaceable

30

35

filters implemented filtering means 3 for filtering of outdoor air  $u$ , indoor air  $s$  and/or mixed air  $us$ .

5 As a further advantageous embodiment, in the supply air apparatus according to the invention it is possible to utilize an extra-low voltage, typically e.g. at 5-24 V voltage, operated device blower, the power supply and control of which may be carried out in a significantly simpler and safer manner than on mains current operated  
10 devices.

Adjusting the capacity of the device blower may be carried out in addition to or alternative to stepless voltage adjustment also by using e.g. parallel device  
15 blowers with on/off-principle, which means that maximal production is produced by using all device blowers and minimum production by using just one.

20 As an advantageous actuator in practice may be mentioned a product, being marketed with the type name NF-R8, which, thanks to the noise damping technique used therein, makes possible an air distribution device that has a very silent operating sound.

25 It is clear that the invention is not limited to the embodiments presented or described above, but instead it can be modified significantly within the basic idea depending on the installation site at any given time. It is thus clear that the shape of the replacement air  
30 valve may, differing from the elongated implementation as shown in the figures, also be more spotlike that is e.g. round, square shaped etc. by its cross-section. In this context, it is furthermore worth noticing that thanks to the invention, existing replacement air val-  
35 ves need not to be fixed, but instead, the possible filters and adjustment arrangements therein may still be utilized according to the original purpose of use thereof. The technique of the air distribution device

in the supply air apparatus according to the invention  
may alike be varied by using e.g. a mains current or  
accumulator operated blower arrangement, the adjustment  
of the functionings of which may also be carried out  
5 with traditional wired adjustment arrangements or e.g.  
with cloud server principle from outside the apartment  
through a server e.g. in order to control the ventila-  
tion of the apartment when the apartment is empty in  
the winter or in other kinds of corresponding situ-  
10 ations.

Claims:

1. Supply air apparatus, which is meant for producing outdoor air into an indoor space assisted by an auxiliary powered, preferably electrical, blower arrangement (1) by simultaneously mixing the outdoor air (u) to be brought into the indoor space with air from the indoor space (s), wherein the supply air apparatus comprises in connection with an outdoor air flow way that exists in a structure (W) in a building between the indoor space and outdoor air a flow space (V) along with its flow connections for outdoor air and indoor air for mixing the above with each other, the blower arrangement (1), such as one or more, preferably on axial principle operated, blowers, and a blow flow arrangement (2) for leading a mixed flow of air (us) into the indoor space in the building, **characterized** in that, the supply air apparatus comprises in connection with a supply air device (X), such as a replacement air valve or like, in an outer wall of the building, a built-in air distribution device (Y), which comprises: a box-structured frame (R); an internal flow space (V) in the frame; an inflow arrangement (SV) of outdoor and indoor air that joins with the flow space and opens into an internal space (ST) in the building; the blower arrangement (1), such as one or several parallelly coupled device blowers or like; and the blow flow arrangement (2) that leads the mixed air (us) into the indoor space.

30

2. Supply air apparatus according to claim 1, **characterized** in that, the air distribution device (Y) is arranged in the indoor space (ST1) in the building on an inner surface of an outer wall, such as in a wall or a ceiling, above a supply air device (X), such as replacement air valve (X1) in a window or a like, existing in an outer wall (W) of the building.

35

3. Supply air apparatus to claim 1, **characterized** in that, the air distribution device (Y) is arranged in a space (ST2) between window structures (i1, i2) in a window existing in an outer wall (W) of the building.

5

4. Supply air apparatus according to claim 3, **characterized** in that, feeding of the outdoor air into the air distribution device (Y) is arranged by outdoor air (u) that is led into the space (ST2) between the window structures (i1, i2) in the window through flow ways (iR) existing in connection with the outer window structure (i1) of the window, such as through ventilation openings at a lower edge thereof.

10

15

5. Supply air apparatus according to claim 3 or 4, **characterized** in that, the inflow arrangement (SV1) of indoor air comprises a flow way leading from the indoor space (ST) to the frame (R) for leading of indoor air of the building to the flow space (R, V) in the frame and the inflow arrangement (SV2) of outdoor air comprising a flow way that is open from the frame (R) to the space (ST2) between the window structures.

20

25

6. Supply air apparatus according to any of the preceding claims 3-5, **characterized** in that, the blow flow arrangement (2) comprises a flow way (2a) that leads from the frame (R) into the indoor space (ST) in the building for leading the mixed air (us) into the indoor space (ST1).

30

7. Supply air apparatus according to claim 2, **characterized** in that, the inflow arrangement (SV) for outdoor and indoor air and/or the blow flow arrangement (2) of the air distribution device (Y) that exists on an inner surface of an outer wall (W), such as in connection with a curtain box structure (Z) or like, is/are arranged when viewed in a horizontal plane to be directed in more than one direction.

35

8. Supply air apparatus according to claim 7, **characterized** in that, an end (II) on the side of the output end of the air distribution device's frame (R) is arranged convex towards the indoor space (ST1) in the building.

9. Supply air apparatus according to claim 7 or 8, **characterized** in that, the inflow arrangement (SV) and/or the blow flow arrangement (2) of the air distribution device comprise/comprises in one or more parts, when viewed from the side in an inclined position from the frame (R) outwards directed guide surfaces (OP) for guiding the air flows in a direction of height.

10. Supply air apparatus according to any of the preceding claims 1-9, **characterized** in that, the air distribution device comprises with cleanable and/or replaceable filters implemented filtering means (3) for filtering of outdoor air (u), indoor air (s) and/or mixed air (us).

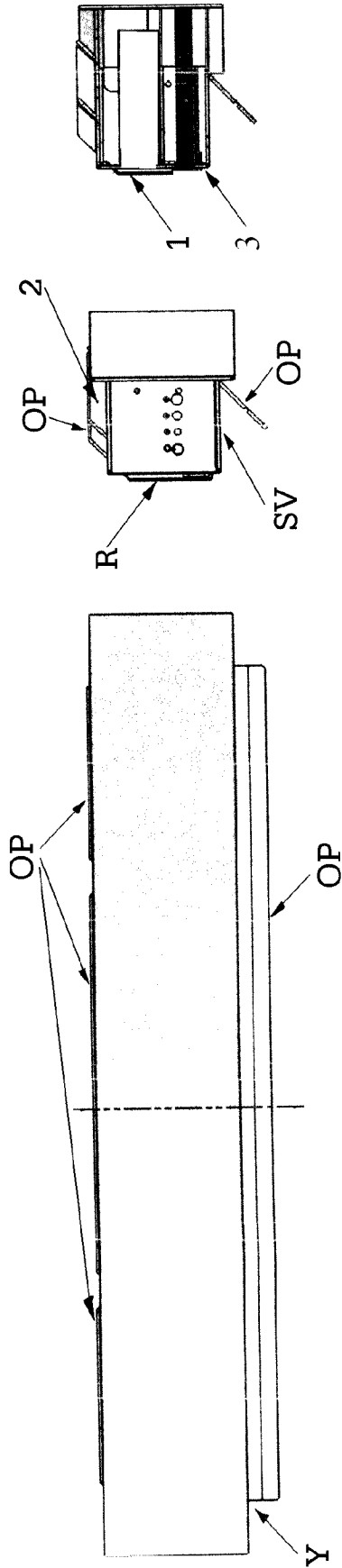

FIG. 1c

FIG. 1b

FIG. 1a

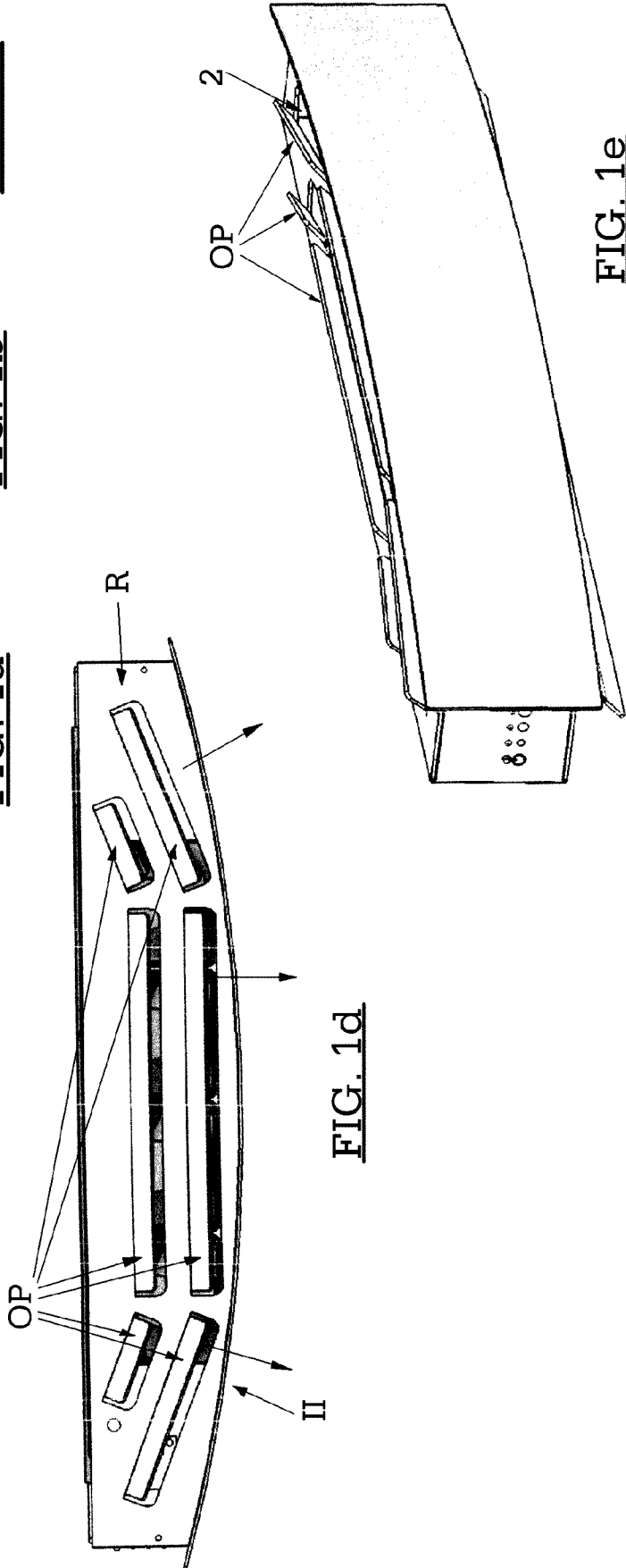

FIG. 1e

FIG. 1d

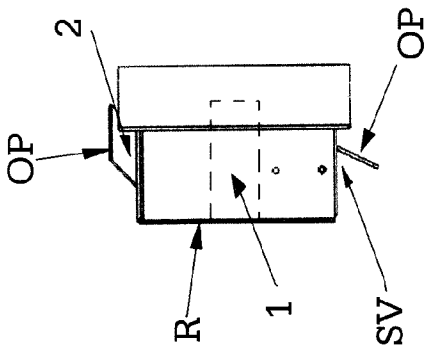

FIG. 2b

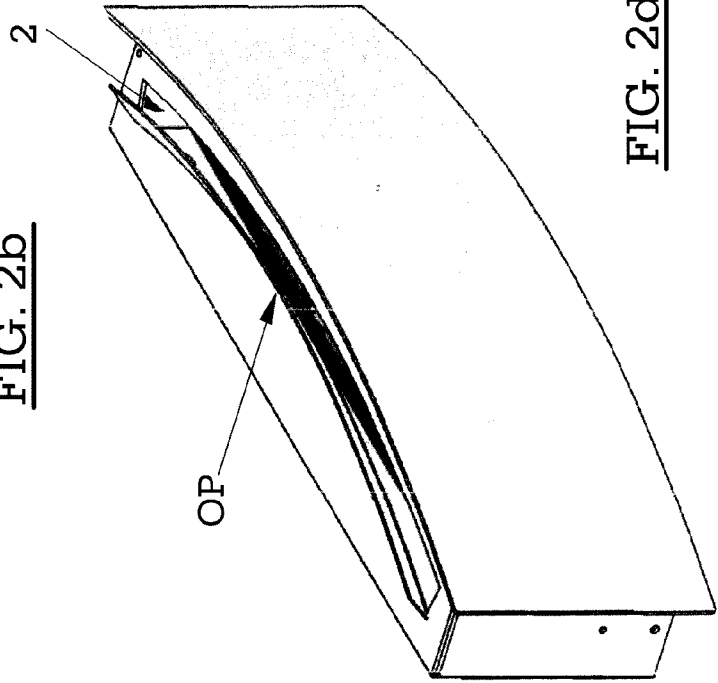

FIG. 2d

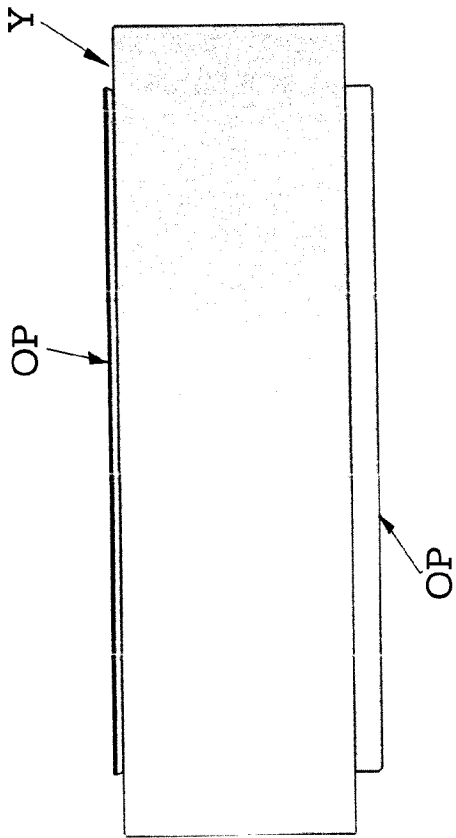

FIG. 2a

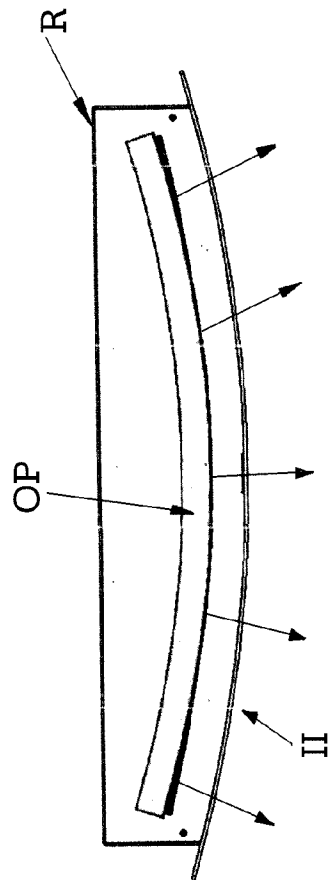

FIG. 2c



4/5

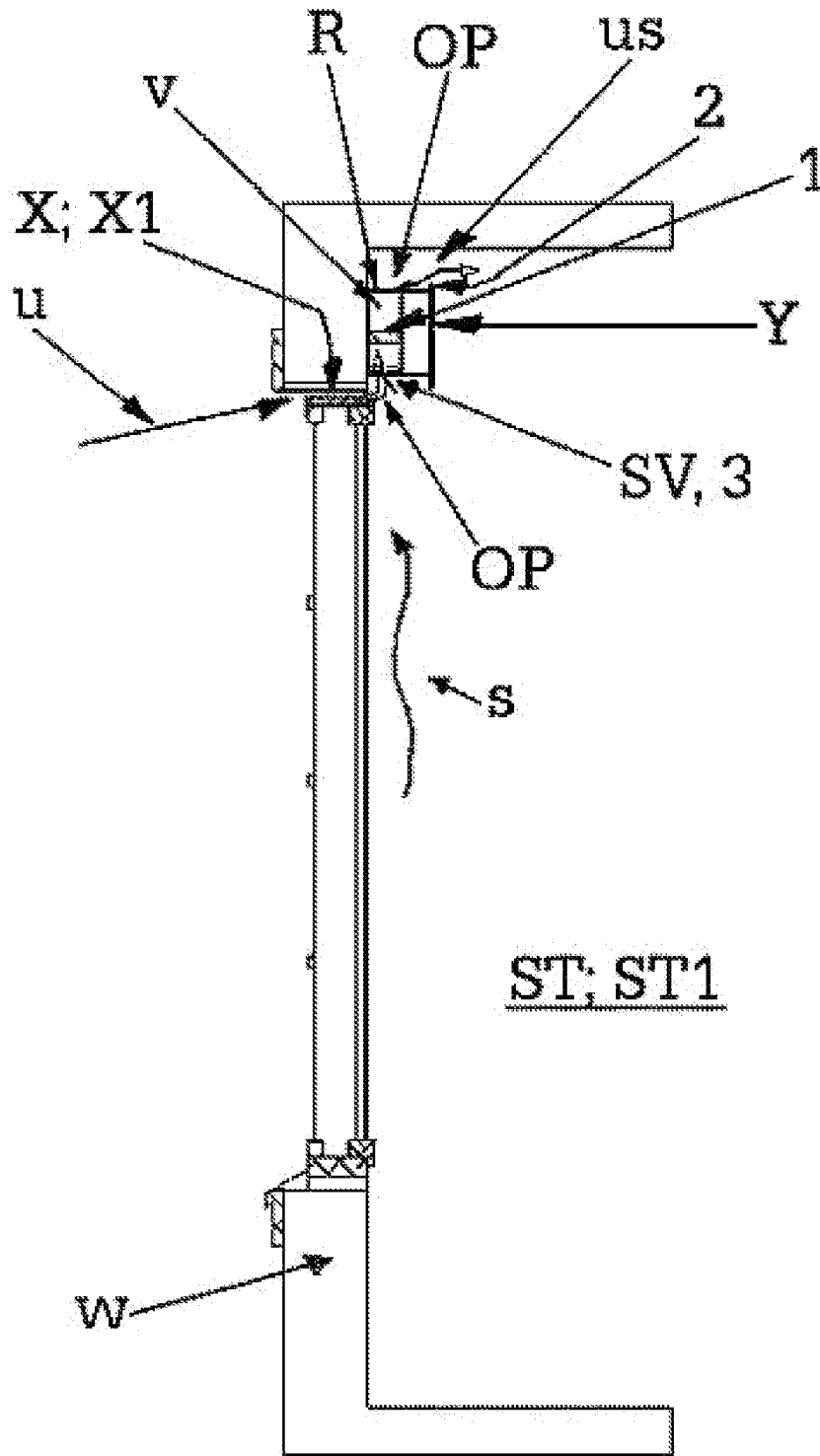

FIG. 4

5/5

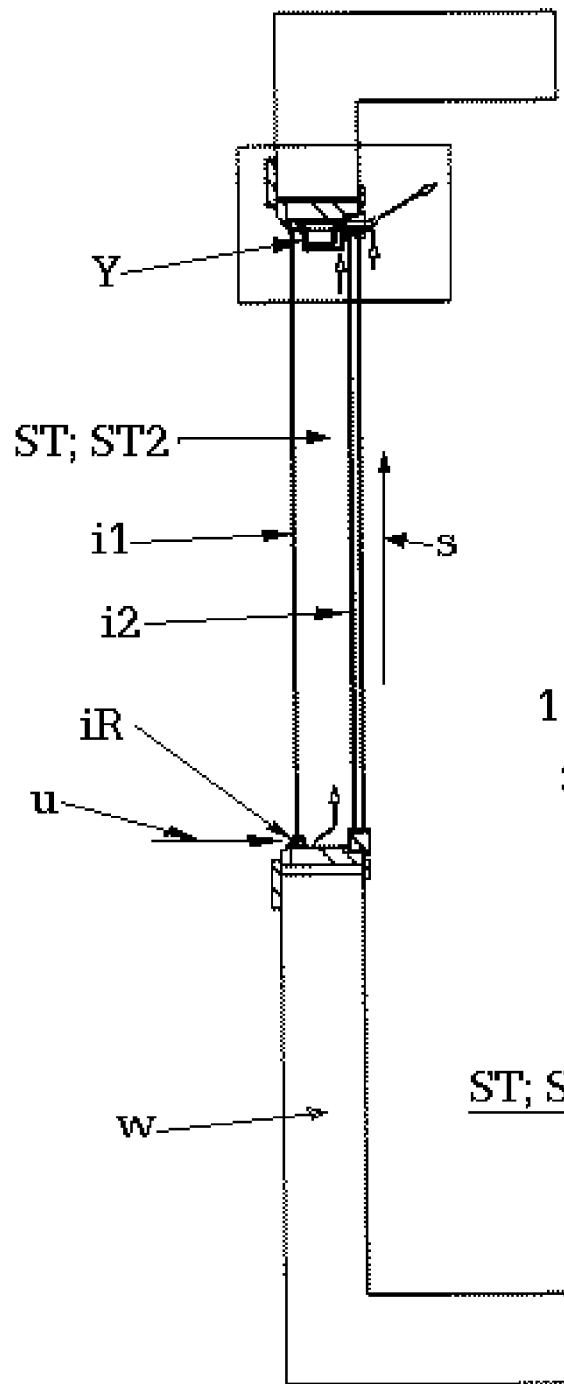

FIG. 5a

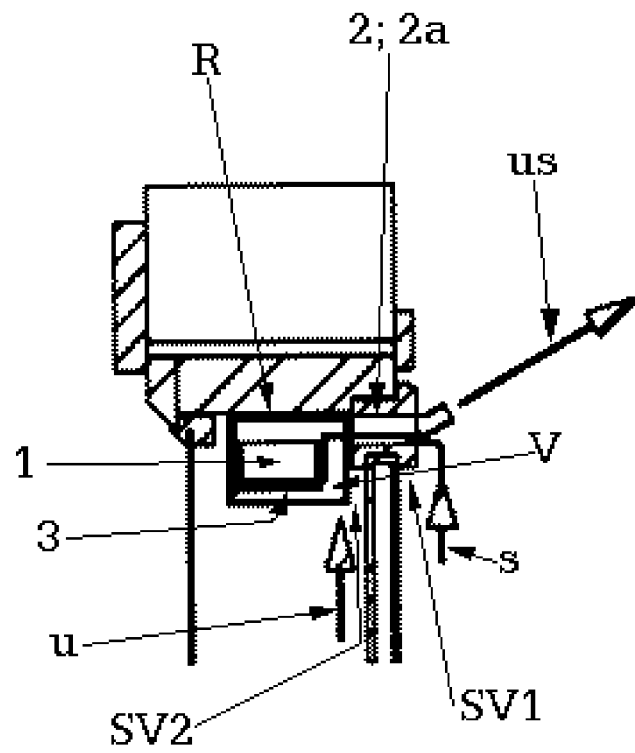

FIG. 5b

**INTERNATIONAL SEARCH REPORT**

International application No.  
PCT/FI2014/050599

A. CLASSIFICATION OF SUBJECT MATTER		
IPC: see extra sheet According to International Patent Classification (IPC) or to both national classification and IPC		
B. FIELDS SEARCHED		
Minimum documentation searched (classification system followed by classification symbols) IPC: E06B, F24F		
Documentation searched other than minimum documentation to the extent that such documents are included in the fields searched SE, DK, FI, NO classes as above		
Electronic data base consulted during the international search (name of data base and, where practicable, search terms used) EPO-Internal, PAJ, WPI data		
C. DOCUMENTS CONSIDERED TO BE RELEVANT		
Category*	Citation of document, with indication, where appropriate, of the relevant passages	Relevant to claim No.
X	US 6168517 B1 (COOK E F), 2 January 2001 (2001-01-02); abstract; column 1, line 53 - column 2, line 9; column 3, line 49 - column 4, line 17; column 8, line 33 - line 45; figures 1-3 --	1-10
A	AT 389347 B (PALOHEIMO OY), 15 April 1989 (1989-04-15); page 2, line 41 - page 3, line 5; page 3, line 16 - line 19; figure 1 --	3-6
A	GB 2424059 A (CAN DO CORP LTD), 13 September 2006 (2006-09-13); page 9, line 18 - line 28; page 11, line 16 - line 20; page 12, line 11 - line 15; page 12, line 20 - line 32; page 13, line 20 - line 26; figure 3 -- -----	3-6
<input type="checkbox"/> Further documents are listed in the continuation of Box C. <input checked="" type="checkbox"/> See patent family annex.		
* Special categories of cited documents: "A" document defining the general state of the art which is not considered to be of particular relevance "E" earlier application or patent but published on or after the international filing date "L" document which may throw doubts on priority claim(s) or which is cited to establish the publication date of another citation or other special reason (as specified) "O" document referring to an oral disclosure, use, exhibition or other means "P" document published prior to the international filing date but later than the priority date claimed "T" later document published after the international filing date or priority date and not in conflict with the application but cited to understand the principle or theory underlying the invention "X" document of particular relevance; the claimed invention cannot be considered novel or cannot be considered to involve an inventive step when the document is taken alone "Y" document of particular relevance; the claimed invention cannot be considered to involve an inventive step when the document is combined with one or more other such documents, such combination being obvious to a person skilled in the art "&" document member of the same patent family		
Date of the actual completion of the international search 29-04-2015		Date of mailing of the international search report 29-04-2015
Name and mailing address of the ISA/SE Patent- och registreringsverket Box 5055 S-102 42 STOCKHOLM Facsimile No. + 46 8 666 02 86		Authorized officer Jenny Petersson Eklund Telephone No. + 46 8 782 25 00

**Continuation of:** second sheet

**International Patent Classification (IPC)**

*F24F 7/007* (2006.01)

*E06B 7/02* (2006.01)

**INTERNATIONAL SEARCH REPORT**  
Information on patent family members

International application No.  
**PCT/FI2014/050599**

US	6168517 B1	02/01/2001	NONE
AT	389347 B	15/04/1989	NONE
GB	2424059 A	13/09/2006	NONE