

April 6, 1937.

K. J. DOLLAHITE

2,076,177

PRINTING MECHANISM

Filed May 18, 1936

3 Sheets-Sheet 1

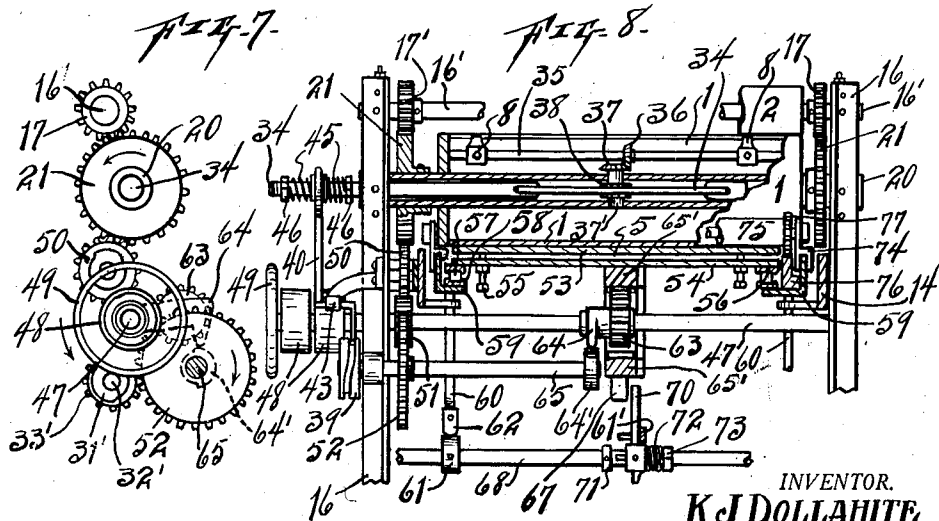
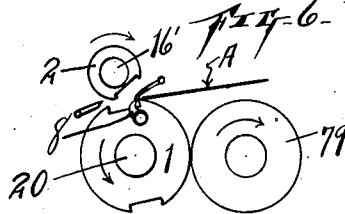
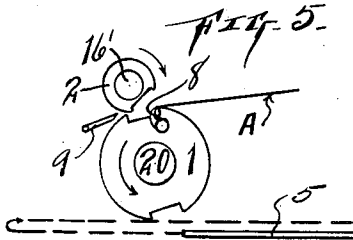
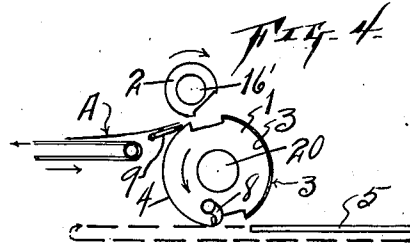
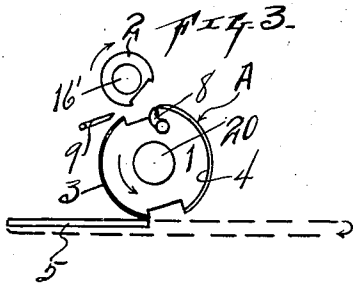
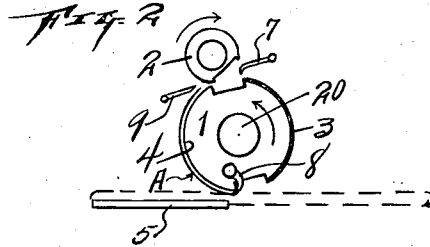
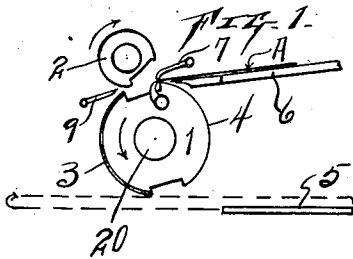

INVENTOR.  
**K. J. DOLLAHITE.**

BY *John C. [Signature]*  
ATTORNEY

April 6, 1937.

K. J. DOLLAHITE

2,076,177

PRINTING MECHANISM

Filed May 18, 1936

3 Sheets-Sheet 2

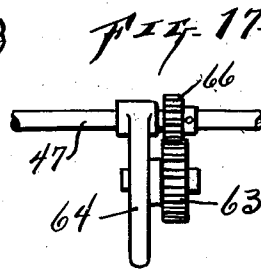
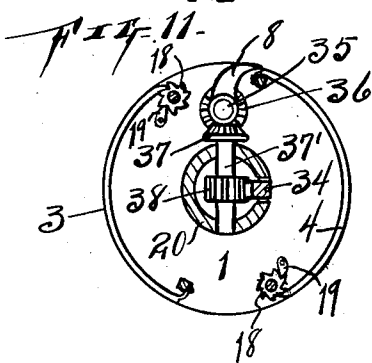
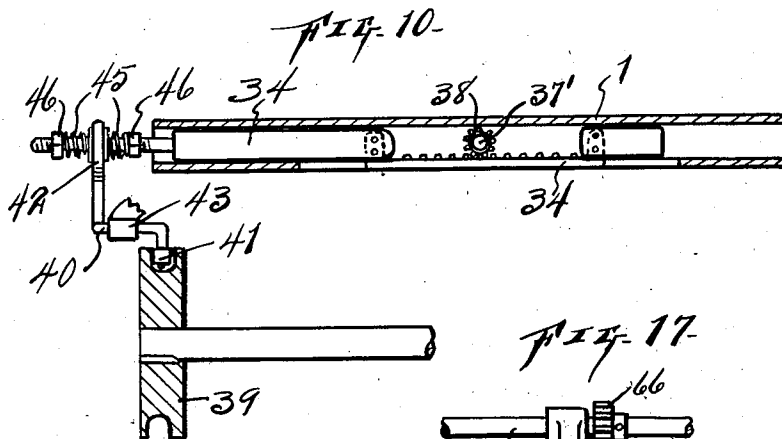
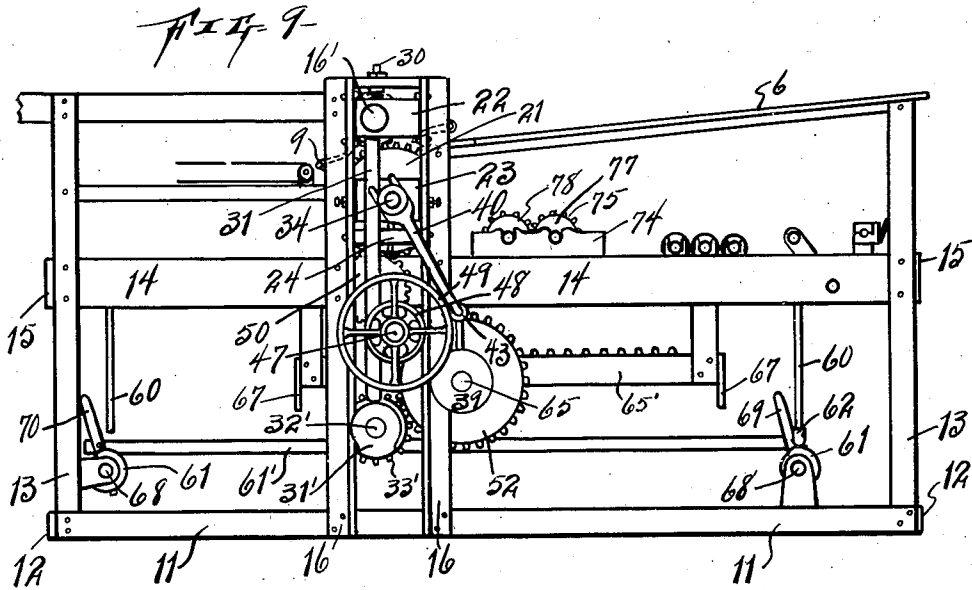

INVENTOR  
K. J. DOLLAHITE.

BY  
*John C. [Signature]*  
ATTORNEY.

April 6, 1937.

K. J. DOLLAHITE

2,076,177

PRINTING MECHANISM

Filed May 18, 1936

3 Sheets-Sheet 3

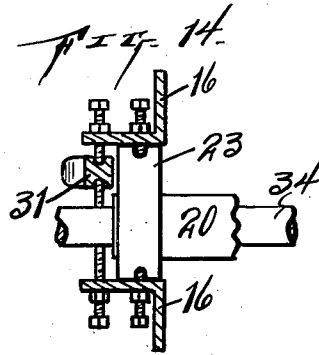
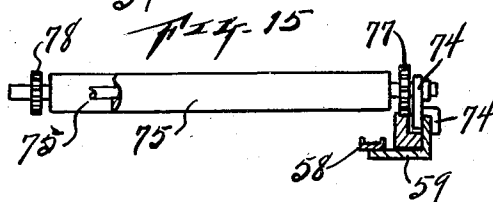
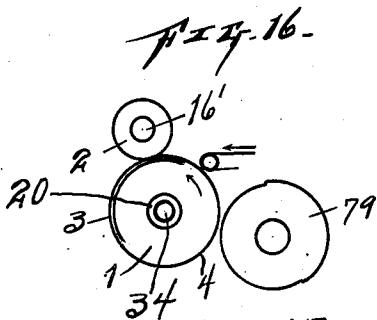
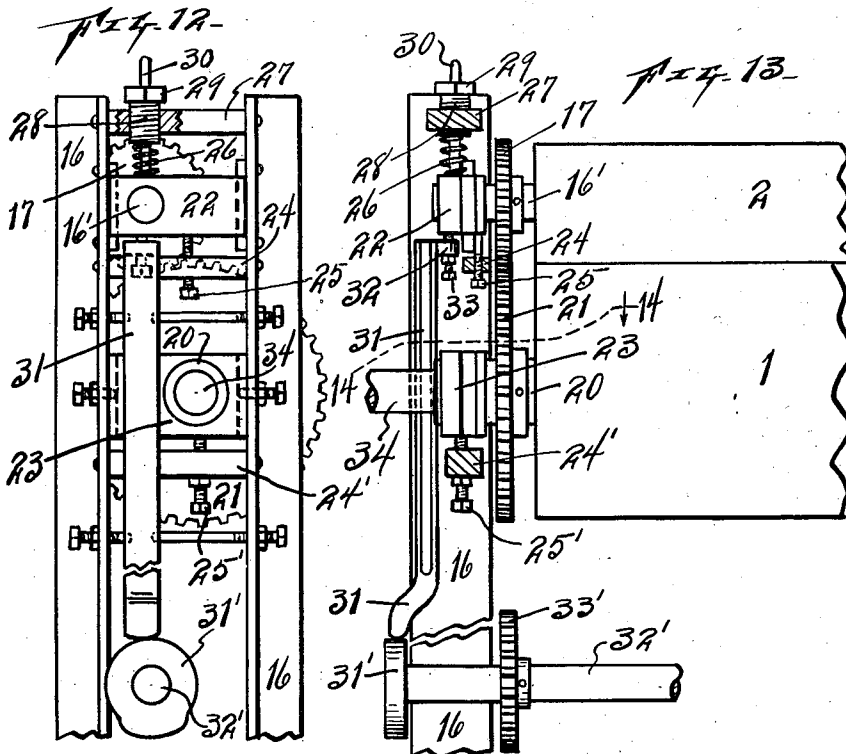

INVENTOR.

K. J. DOLLAHITE

BY *John E. Miller*  
ATTORNEY

# UNITED STATES PATENT OFFICE

2,076,177

## PRINTING MECHANISM

Kenneth J. Dollahite, Fort Worth, Tex.

Application May 18, 1936, Serial No. 80,363

3 Claims. (Cl. 101—215)

My invention relates to printing presses and more particularly to a press which will accomplish a class of work commonly known as planographic "off set" printing, but which will do so without the use of planographic "off set" plates; and the object is to provide a rotary or reciprocal form of printing press of a simple and inexpensive design which is adapted to use an ordinary type form composed of type, half-tone cuts, etchings, and/or any other cuts or blocks designed to print from a flat bed, in the form of type, that is to say, in the form which when printed, produces a readable print from the first impression, as ordinary printer's type, or a plate etched in the negative form from a print or transfer of ordinary type form or cut.

It has been definitely proven that the finished work of this machine can be made to "cover" better and be of greater brilliancy than the conventional planographic "off set" work, as it is so mechanically constructed that the "negative" transfer cylinder receives two inkings from the "positive" transfer cylinder to each impression on the sheet printed.

In the type of press wherein I use the reciprocation of the bed plate, the type form is locked in a chase on the flat bed, in the same manner as the ordinary flat bed cylinder letter press. In the reciprocal as in the rotary type form of press, I am enabled to produce genuine "off set" work without the use of the conventional planographic "off set" plate, and direct from a type form without the usual "make ready", thus providing a principle of printing which is less expensive in operation and requires less time to produce.

This inexpensive method of speeding up the work is by elimination of "make ready" as used in letter presses, the water roller principle used in the conventional planographic "offset" method, and the elimination of all photographic equipment and procedure. This system of "off setting" direct from a type form not only eliminates the "make ready" and the time therefor, but practically eliminates all causes for wearing or breaking down the finest lines of a plate, type form, or cuts, and the result is a perfect lithographic effect. Because of the elimination of the "water roller" method, and the sensitized plate of the ordinary planographic offset press, this invention provides means for printing enamelled paper, as there is no sensitized plate to be injured by the injurious properties present in the paper.

It has been found in the use of this printing

press that the work is far superior in appearance to letter press printing, as it has no "impression" through the paper, and produces a sharper print at less cost than the ordinary letter press printing. As there is no "impression" through the paper, there is no danger of "off setting" on the back or reverse side of the paper or curling of stock, commonly experienced in letter press printing, thus permitting a quicker delivery of work. The absence of the "impression" on the paper permits the paper to lie more compactly, which permits greater ease in handling and requires less storage space.

Another advantage of this press is that it requires less ink than the conventional letter press, and gives longer life to the form rollers.

Still another advantage of this method of printing is that the absence of impression direct on the cut or plate permits the production of a finer detail, as the depth of the etching may be less than that for letter press printing, which produces a finer "detail". Where a screen effect is desired, it may be accomplished from a solid block or plate by placing a cloth of the desired fineness or weave around the platen portion of the platen roller, thus eliminating the necessity and cost of having a screen half-tone, as required in the conventional machines.

Another advantage of this invention is that tint blocks, borders, geometrical designs, etc., or any figure or shape which can be designed from leather, press-board, linoleum, etc., are successfully used, as the only pressure on the block or plate is that of the primary transfer surface. That is to say, any substance of a nature that can be placed on the bed plate and receive an inking, and withstand the slight pressure of the primary transfer surface and the form rollers, may be used to impart its natural texture or design on the work.

Still another advantage of this invention is that the simplicity of structure and principle does not require the attention of a highly skilled operator, and the absence of all photographic equipment permits the production of superior work at a minimum expense, and in less time than is possible to obtain on the conventional design of planographic offset or letter presses. Another important advantage of this invention is that the type of press which carries a metallic printing surface for the negative transfer roller, having the necessary resilience under the sheet, gives greater brilliancy to the printing than ordinary lithographic work, as the metallic

surface acts as a polisher, as in letter press printing.

Other objects and advantages will be fully explained in the following description, and the invention will be more particularly pointed out in the claims.

Reference is had to the accompanying drawings which form a part of this application.

Fig. 1 is a diagrammatic view of the rollers, bed plate, guides, strippers, and grippers of the press, showing the press in position for receiving a sheet of paper. In this view, the transfer roller is down and in position to impart the print to the paper.

Fig. 2 is a similar diagrammatic view, showing the position of the above-named parts when the combination cylinder has turned a half turn from that shown in Fig. 1.

Fig. 3 is a similar view, showing the position of the relative parts when the cylinder has turned another half turn from that shown in Fig. 2.

Fig. 4 is a diagrammatic view of the same, showing the cylinder moved another half turn or one and a half turns from the position shown in Fig. 1.

Fig. 5 is a similar view, showing the parts of the press in the same position as that shown in Fig. 1.

Fig. 6 is a diagrammatic view of the same, showing the adaptation thereof to a rotary form of plate carrier.

Fig. 7 is a diagrammatic view of the ends of the cylinders, showing their gearing and the method of driving the same.

Fig. 8 is a vertical section of the two rollers or cylinders, showing the gearing for actuating the same, control of the bed plate, and other control medium for the various roller cooperating parts.

Fig. 9 is a side elevation of the press, showing a suggested form thereof and inking means for the type form of the reciprocating bed plate.

Fig. 10 is a detail view of the means for controlling the grippers of the combination cylinder of the press.

Fig. 11 is an enlarged end view of the one of the two cylinders showing the structure thereof.

Fig. 12 is a detail view of the resilient anchorage of the axle bearing of the transfer roller of the machine.

Fig. 13 is a similar view taken at right angles to the view shown in Fig. 12.

Fig. 14 is a plan view of the same.

Fig. 15 is a detail view of the means for sliding of the form rollers on the frame of the bed of the press.

Fig. 16 is a diagrammatic view of the two rollers or cylinders in operative relation with a rotary form of type or plate carrier.

Fig. 17 is a plan view of the reciprocating gear of the press bed and means of journalling same.

As the primary object of this invention is to provide a method of off-set printing by means of two rollers, I provide a combination cylinder 1, which is rotatably disposed relative to the type form, or plate; and a secondary transfer cylinder or roller 2 in operative relation with the cylinder. In the first six figures of the drawings, I show a diagrammatic illustration of the steps taken in acquiring off-set work direct from type form without the conventional planographic process, equipment, and time for make-ready.

Fig. 1 consists of an end view of a combination cylinder 1 which serves as a primary transfer composition roller and a platen. Approximately one-half of the cylinder 1 is provided with

suitable removable resilient composition surface 3 to serve as a positive transfer roller from the type form. The other half of the cylinder surface is provided with a platen surface 4 suitable for the use of a tympan and packing for carrying the paper to be printed upon. In this view, as in the succeeding four views, the press is provided with a reciprocating bed 5. In Fig. 1 the press is in position for receiving a sheet of paper A or other medium to be printed upon. The paper is moved on the feeder board 6 into contact with the guides 7 and in position to be held on the platen by the grippers 8 which are carried in the cylinder 1. In this position, the strippers of the press or raised and the transfer roller 2 is down and in position, relative to the cylinder 1, to transfer the impression to the paper as the paper passes between the cylinder 1 and secondary roller 2. At this instant, the type or form carrier 5 is in its lower position under the feed board 6 and ready to move to the opposite end of the press.

When the combination cylinder 1 has moved a half turn from its position when receiving the paper, (see Fig. 2) the transfer roller 2 has made a complete revolution and imparted the impression to the sheet A carried on the platen 4 of the cylinder 1, and the bed 5 has travelled towards the opposite end of the press.

A further half turn of the cylinder 1, which is a full revolution from the position in which it received the paper, (see Fig. 3) the composition 3 of the cylinder 1 has imparted its impression to the secondary roller 2; the transfer roller 2 is ready to raise and permit the strippers 9 to strip the paper from the platen 4. At this time, the type form carrier 5 is in an up position under the stripper fingers and ready to travel back under the feed board 6 of the press.

Another half turn of the combination cylinder, as shown in Fig. 4, which would be a turn and a half of the same from its receipt of the sheet of paper, delivers the sheet of paper upon a conveyor belt 10 and the transfer roller 2 drops to receive the print again from the composition portion 3 of the cylinder 1. At this position of the press, the carrier 5 is back under the feeder board in an up position and has imparted its impression to the portion 3 of the combination cylinder 1.

A further turn of the combination roller, which is a full two turns of the same from its receipt of the sheet of paper and as shown in Fig. 5, positions the same again in the position as shown in Fig. 1. In this position it is again ready to repeat the movements stated above.

It is obvious that, from the description of the movements of the relative parts of the machine, that the transfer roller 2 receives two inkings from the composition surface 3 of the cylinder 1 for each sheet of paper passed through the press; that for each rotation of the combination cylinder 1, the type form 5 travels from one extreme to the other of its reciprocation; that the transfer roller 2 makes two revolutions to one of the combination cylinder 1; and that the transfer roller is in engagement with the combination cylinder at all times except when the paper is stripped from the cylinder 1 by the fingers 9.

In order to assemble and control the above-named parts of the press and make them function together to obtain the desired result, I provide a frame which consists of a rectangular base form having side members 11 and end members 12

12. These members are rigidly attached together at their respective ends and the corners thereof are provided with uprights 13 made rigid therewith and adapted to act as supports for a second horizontally placed rectangular frame disposed in alignment with and above the first rectangular frame. This second rectangular frame consists of side members 14, the ends thereof being rigidly attached to end members 15. A pair of angular castings 16 are made rigid with the sides of both rectangular frames and are vertically disposed parallel with each other so as to serve as bearing support for the axis of the two rollers. The brackets 16, adjacent the main gearing, are anchored to 14 by means of a bracket.

The upper roller or the transfer roller 2, may consist of a plain metallic surface to receive the print from the lower cylinder or combination cylinder 1, or may be constructed to carry the conventional rubber blanket or other suitable substance. The roller 2 is provided with a central shaft 16' made rigid therewith and provided with keyed gears 17 on each end thereof. When the rubber substance is carried on the surface of the roller 2, it may be attached in the conventional manner, that is, one edge is made rigid with the roller and the other edge passed over a medium for controlling the tension of the substance on the roller. In this instance the edge of the rubber blanket is passed over a square shaft and fastened thereto which is journaled in the roller and provided with a ratchet wheel 18 keyed or otherwise rigidly secured thereto. A dog 19 is positioned in the roller so as to cooperate with the wheel 18 so that when tension is taken on the blanket by turning the shaft, the dog 19 will engage and hold the wheel 18 of the shaft from turning.

A similar structure is provided for holding the primary transfer surface 3 and the tympan surface 4 on the cylinder 1 of the press (shown in Fig. 11). In this instance, the cylinder 1 is provided with two elongated openings positioned on opposite sides of the axis of the cylinder for installation of the surface control units of the same. The relative diameter of the two rollers 1 and 2 permits the upper roller or the roller 2 to travel two turns to one of the cylinder 1. The transfer roller 2 is provided with one elongated slot or opening of the same width, more or less, as the openings of the cylinder 1. As the cylinder 1 rotates one turn, the surface of the transfer roller 2 will contact with the transfer surface 3 and then with the sheet of paper passed through the press.

The combination cylinder 1 is provided with a rigid axle 20 having gear wheels 21 made rigid with each end thereof and adapted to mesh with and drive the gears 17 of the transfer roller 2. This axle 20 is preferably a hollow cylinder or tube through which the actuating mechanism of the grippers 8 may be passed. The extreme outer ends of the axes of the transfer roller 2 and the cylinder 1 are provided with bearings 22 and 23 respectively which are anchored between the parallel upright members 16 of the press frame.

A bar 24 is made rigid with the pair of members 16 and positioned below the bearing 22 so as to span the space between the pair of members and adjustably support the bearing 22 by means of set screws 25. The extreme lower position of the transfer roller 2 may be determined by screwing the set screw 25 in and out of the bar 24. The bearing 22 rests upon the set screw 25 and is resiliently held thereagainst by means

of a coil spring 26. A second bar 27 is similarly attached to the pair of members 16 and positioned above the bearing 22 to serve as support for the coil spring 26. A hollow exterior threaded member 28 is screwed through the member or bar 24 in the direction of the top of the bearing 22. A nut 29 is made rigid with the top of the member 28 and adapted to serve as a purchase in screwing the member 28 to and from the top of the bearing 22. A bolt 30 is made rigid with the top of the bearing 22 and adapted to telescope through the member 28. The coil spring 26 is positioned around the bolt 30 and interposed between the base of the member 28 and the top of the bearing 22. This structure permits the operator of the press to vary the tension of the transfer roller 2 against the cylinder 1, as shown in Figs. 12 and 13.

The extreme ends of the axles 20 of the cylinder 1 are provided with bearings 23 which are adjustably positioned between the pairs of members 16. The adjustment of the bearings 23 is preferable in case of wear of the press and may be obtained by any suitable manner, preferably by positioning the bearings 23 between the member 16, similar to the position of the bearings 22, and adjustably anchor them by means of a cross member 24' which spans the space between each pair of members 16.

The raising of the transfer roller 2 to permit passage of the sheet of paper after it has received the impression, consists of providing a reciprocating shaft 31 slidably mounted in the press so that it will engage the bearing 22 of the transfer roller 2 and compress the spring 26. The upper end of the shaft 31 is provided with a lug 32 made rigid therewith and adapted to extend under the bearing 22. A set screw 33 is passed through the lug 32 and against the base of the bearing 22 so that adjustment thereof will vary the extent to which the shaft 31 will raise the transfer roller 2.

In the operation of the grippers 8, the press is preferably provided with a reciprocating rack 34 slidably mounted in the hollow shaft axle 20 of the cylinder 1 and adapted to be actuated by suitable gearing from the drive medium of the press. In this instance, the grippers 8 are adjustably mounted rigidly upon their shaft 35. The shaft 35 is journaled in the cylinder 1 parallel with the axis thereof and provided with a gear wheel 36 made rigid therewith. A gear wheel 37 is provided with a rigid axle 37' journaled in the shaft 20 and positioned therein so as to mesh with and drive the wheel 36. The rack gear 34 is adapted to mesh with and drive a gear wheel 38 which is also made rigid with the axle 37' and positioned within the hollow shaft 20. The reciprocation of the rack gear may be accomplished as shown in Fig. 10. In this instance, a shaft which is suitably geared with the drive medium of the press is provided with a cam 39 keyed thereto and provided with a peripheral surface adapted to move the grippers 8, through cooperating mechanism, so that they will positively open and close the fingers at the desired time. A shaft 40 is provided with a roller 41 journaled thereon and adapted to ride in the groove of the cam. The other end of the shaft is provided with a yoke 42 which is adapted to pass around the end of the rack 34 and be resiliently connected thereto so that the cam 39 may move the shaft 40 in its bearing 43 and reciprocate the rack 34. A pair of coil springs 45 are positioned around the outer end of the reciprocating rack 34, one on each side

of the yoke 42, and adjustably held thereon by means of bolts 46. The object of this form of resiliently connecting the yoke of the control shaft 40 with the rack 34 is to vary the tension on the grippers 8 and to provide means of connection that will not hinder the rotation of the shaft 34 with the rotation of the cylinder 1. It is apparent that other means may be used for the control of the grippers as well as control of the various parts of the press. As it is possible for the press to be built with conventional means of control of the strippers 9 and guides 7, the mechanism therefor is not shown in this application. This is also true of a few of the other parts which are well known in the art and may be provided with conventional structure for operating them and timing them in accordance with the method of printing as herein outlined.

A form of gearing the two rollers is presented in Figs. 7 and 8, in which a master drive shaft 47 is journaled in the frame of the press and provided with a pair of pulleys 48. The pulleys 48 cooperate with the shaft 47 in the conventional manner so that the drive medium, belted to one and then the other of the pulleys, will impart rotation to the shaft at the will of the operator. The shaft 47 may also be provided with a fly wheel 49 keyed thereto and positioned in a convenient place so that it may be turned manually by the operator of the machine. An idler 50 is rotatably mounted in the press frame and meshed with both the gear wheel 21 of the cylinder 1 and a gear wheel or pinion 51 of the master shaft 47. The pinion 51 is keyed to the shaft 47 and also meshed with a gear wheel 52 which is provided with a rigid shaft journaled in the press frame and adapted to control the reciprocation of the bed of the press. This form of gearing will serve to actuate the combination cylinder and the secondary transfer roller, control the bed reciprocation, and may be utilized to actuate various attachments carried in the press.

The bed of the press may consist of a table 53 horizontally adjustably positioned on a frame member 54 by means of bolts 55 which are rotatably connected to the table 53 and adapted to screw through the frame member 54. The frame 54 is provided with a track 56 made rigid with each side thereof and adapted to serve as guides for anti-friction rollers 57. A second track 58 is made rigid with a frame member 59 and positioned directly under the track 56 so that the rollers may travel between the two tracks 56 and 58 during the reciprocation of the bed 5. The frame 58 is preferably rectangular in form and provided with rods 60 made rigid with each corner thereof and vertically disposed so that their lower ends may be adjustably supported by cams 61. The lower ends of the rods 60 are threaded and provided with adjusting nuts 62 screwed thereon and adapted to rest upon the outer periphery of the cams 61. The cams 61 of each end of the rectangular form 58 are provided with a rigid axle journaled in the frame at right angles to the reciprocation of the bed 5 and adapted to be actuated by the bed so that the same may be raised and lowered during the reciprocation thereof.

The reciprocation of the bed is attained, in this instance, by providing a pair of gear racks on the under surface of the frame 54 of the press so that one rack is above the other. The two racks are made rigid with each other and with the frame 54 so that a gear wheel, commonly termed as a star wheel 63, will mesh with one

and then the other of the gear racks 64 so that it will cause the bed 5 to reciprocate during the continuous rotation of the star wheel. The star wheel 63 is journaled in an arm 64 one end of which is pivoted to the shaft 47 and the other end formed to ride upon the outer periphery of a cam 64' which is keyed to the axle 65 of the gear wheel 61. The rotation of the axle 65 will cause the cam to act to move the star wheel 63 intermittently into mesh with one and then the other of the rack gears 64 for reciprocating the bed of the press. A gear 66 is keyed to the shaft 47 and adapted to mesh with and drive the star wheel 63.

The axle of the cams 61 is provided with arms so that lugs 67 rigidly carried on each end of the bed will contact one and then the other for moving the cams 61 and raise and lower the bed 5. The cams 61 on each end of the press are provided with a common axle 68 which is journaled in the frame and positioned at right angles to the reciprocation of the bed. One arm 69 is keyed to the shaft or axle 68 and adapted to be moved so that the cams thereof will lower the bed, and the other arm 70 is connected by means of a key to the other axle 68 so that it may be engaged and moved to raise the bed. The two arms 69 and 70 are linked together by means of a link bar 61', each end of which is pivotally connected to its respective arm. A collar 71 is rigidly positioned on the shaft 68 in position so that the arm 70 may be resiliently held thereagainst so that it may be engaged by the bed lug 67. A coil spring 72 is carried on the shaft 68 so that it will engage the side of the arm 70, opposite the side of the arm against the shaft collar 71, and resiliently hold the arm against the collar. A threaded nut 73 is carried on the shaft 68 so that it will bear against the other end of the spring and moving the nut on the shaft will vary the tension of the pressure of the arm 70 against the collar. By placing the arm in a resilient movable position on the shaft 68, tripping mechanical connection may be made for moving the arm out of the path of the lug 67 and permit the bed to remain in its lower position when the operator of the press so desires. This tripping means may also be connected to the control rod 31 of the transfer roller 2 in any desired manner (not shown).

Inking facilities for the type forms on the reciprocating type form bed 5 may be of the conventional structure, or similar to that shown in Fig. 9 in which the form rollers are journaled in a sliding frame which is positioned on the frame member 59 of the bed and adapted to be moved in a reciprocating movement in the reverse direction of the reciprocation of the bed. This insures a complete distribution of the ink and permits distribution of the same without lengthening the movement of the bed and its cooperating parts. The frame 74 is slidably mounted on the bed frame so that it may raise and lower therewith, similar to the other inking mechanism, and serve as bearings for the axles of the form rollers 75. A rack is made rigid with the frame 59 and serves as a means for revolving the form rollers 75. When two or more rollers 75 are used, it is preferable to stagger the rack engaging gear wheels so that one gear 77 engages one rack 76 and a gear 78 engages and meshes with the other rack gear 76 so that the rollers 75 may be positioned closer together. The rack gear 76 meshes with and drives the gear 77 which is made rigid with the axle of the roller 75.

The rotary form of plate carrier, as illustrated in Fig. 16, may be of the conventional cylindrical form, preferably of the same size as the combination roller or cylinder 1, and positioned under the feed board 6 and adjacent the cylinder 1. The structure of the plate cylinder 79 may be of the conventional type adapted to hold a negative plate (that is in the reverse of reading matter), either in the relief or planographic form. In the latter case however, the conventional water roller system (not shown) would be used.

It is apparent that various changes may be made in the structure of the rollers and their related parts, especially in the method of operation of the control system, without departing from the spirit of my invention. I have found by experience that the substance of the combination cylinder must be of a resilient material which can be ground to precision after being cast and must be impervious to climatic conditions.

What I claim is:

1. In an off-set printing mechanism, means for carrying a type form or plate in negative-relief, a combination cylinder, one side of which is a platen surface, and the other side constructed to carry a resilient composition blanket to serve as a primary transfer surface, and a secondary transfer cylinder, said primary surface of the combination cylinder adapted to receive a positive print from the form or plate, and to transfer a negative print on said secondary transfer cylinder,

which in turn is adapted to impart a positive print on paper carried by the platen side of the combination cylinder.

2. In an off-set printing mechanism, a reciprocable bed carrying a type form in negative-relief, a combination cylinder, one side of which is a platen surface, and the other side constructed to carry a resilient composition blanket to serve as a primary transfer surface, and a secondary transfer cylinder, said primary surface of the combination cylinder adapted to receive a positive print from the form or plate, and to transfer a negative print on said secondary transfer cylinder, which in turn is adapted to impart a positive print on paper carried by the platen side of the combination cylinder.

3. In an off-set printing mechanism, a cylinder for carrying a plate in negative relief, a combination cylinder, one side of which is a platen surface and the other side constructed to carry a resilient composition blanket to serve as a primary transfer surface, and a secondary transfer cylinder, said primary surface of the combination cylinder adapted to receive a positive print from the plate, and to transfer a negative print on said secondary transfer cylinder, which in turn is adapted to impart a positive print on paper carried by the platen side of the combination cylinder.

KENNETH J. DOLLAHITE.