

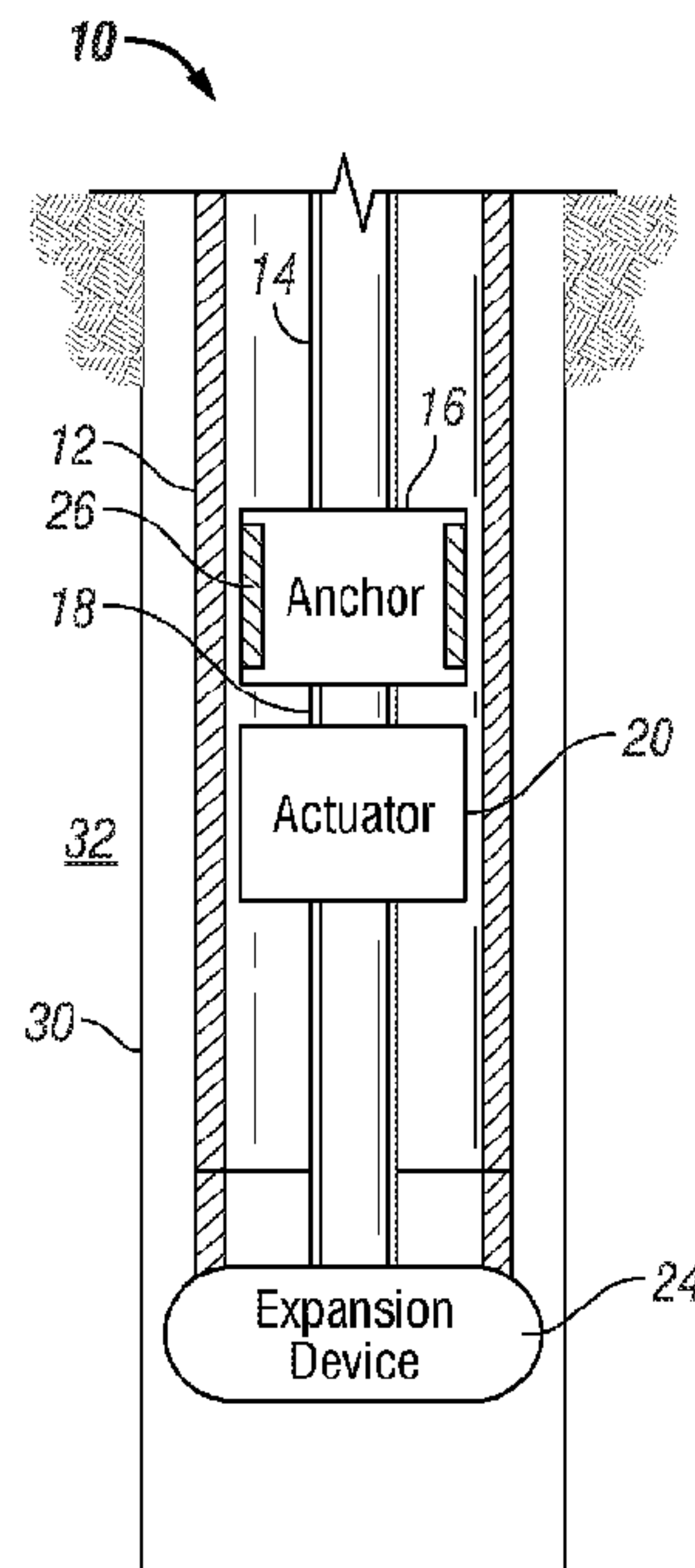

(86) **Date de dépôt PCT/PCT Filing Date:** 2011/11/30  
 (87) **Date publication PCT/PCT Publication Date:** 2012/06/28  
 (45) **Date de délivrance/Issue Date:** 2015/11/03  
 (85) **Entrée phase nationale/National Entry:** 2013/06/05  
 (86) **N° demande PCT/PCT Application No.:** US 2011/062607  
 (87) **N° publication PCT/PCT Publication No.:** 2012/087516  
 (30) **Priorité/Priority:** 2010/12/21 (US12/974,702)

(51) **Cl.Int./Int.Cl. E21B 23/00** (2006.01),  
**E21B 17/06** (2006.01), **E21B 43/10** (2006.01)  
 (72) **Inventeurs/Inventors:**  
 WHIDDON, RICHARD M., US;  
 BENNETT, FREDERICK C., US;  
 BUTTERFIELD, CHARLES A., US;  
 CHOWDHARY, HARSH V., US  
 (73) **Propriétaire/Owner:**  
 ENVENTURE GLOBAL TECHNOLOGY, LLC, US  
 (74) **Agent:** KIRBY EADES GALE BAKER

(54) **Titre : JOINT DE LIBERATION DE FOND DOTE D'UN ELEMENT RADIALEMENT EXTENSIBLE**  
 (54) **Title: DOWNHOLE RELEASE JOINT WITH RADIALLY EXPANDABLE MEMBER**



(57) **Abrégé/Abstract:**

An apparatus comprises an expansion device that is coupled to a support member and operable to be disposed within a tubular member. The expansion device is operable to radially expand the tubular member as the expansion device moves axially through the tubular member. A latch assembly is coupled to the support member and is operable to engage a corresponding latch receptacle disposed within the tubular member so as to limit the axial movement of the expansion device relative to the tubular member.

(12) INTERNATIONAL APPLICATION PUBLISHED UNDER THE PATENT COOPERATION TREATY (PCT)

(19) World Intellectual Property  
Organization  
International Bureau(43) International Publication Date  
28 June 2012 (28.06.2012)(10) International Publication Number  
**WO 2012/087516 A3**

- (51) **International Patent Classification:**  
E21B 23/00 (2006.01) E21B 17/06 (2006.01)  
E21B 43/10 (2006.01)
- (21) **International Application Number:**  
PCT/US2011/062607
- (22) **International Filing Date:**  
30 November 2011 (30.11.2011)
- (25) **Filing Language:** English
- (26) **Publication Language:** English
- (30) **Priority Data:**  
12/974,702 21 December 2010 (21.12.2010) US
- (71) **Applicant (for all designated States except US):** ENVENTURE GLOBAL TECHNOLOGY, LLC [US/US]; 15995 North Barkers Landing, Suite 350, Houston, Texas 77079 (US).
- (72) **Inventors; and**
- (75) **Inventors/Applicants (for US only):** WHIDDON, Richard M. [US/US]; 26507 Clear Mill Lane, Katy, Texas 77494 (US). BENNETT, Frederick C. [JM/US]; 5426 Willowbend Blvd, Houston, Texas 77096 (US). BUTTERFIELD, Charles A. [US/US]; 13922 Prospect Point Dr., Cypress, Texas 77429 (US). CHOWDHARY, Harsh V. [IN/US]; 31 Crestview Trail, Houston, Texas 77082 (US).
- (74) **Agents:** FORINASH, Derek V. et al.; Edmonds & Nolte, PC, 10411 Westheimer Road, Suite 201, Houston, Texas 77042 (US).
- (81) **Designated States (unless otherwise indicated, for every kind of national protection available):** AE, AG, AL, AM, AO, AT, AU, AZ, BA, BB, BG, BH, BR, BW, BY, BZ, CA, CH, CL, CN, CO, CR, CU, CZ, DE, DK, DM, DO, DZ, EC, EE, EG, ES, FI, GB, GD, GE, GH, GM, GT, HN, HR, HU, ID, IL, IN, IS, JP, KE, KG, KM, KN, KP, KR, KZ, LA, LC, LK, LR, LS, LT, LU, LY, MA, MD, ME, MG, MK, MN, MW, MX, MY, MZ, NA, NG, NI, NO, NZ, OM, PE, PG, PH, PL, PT, QA, RO, RS, RU, RW, SC, SD, SE, SG, SK, SL, SM, ST, SV, SY, TH, TJ, TM, TN, TR, TT, TZ, UA, UG, US, UZ, VC, VN, ZA, ZM, ZW.
- (84) **Designated States (unless otherwise indicated, for every kind of regional protection available):** ARIPO (BW, GH, GM, KE, LR, LS, MW, MZ, NA, RW, SD, SL, SZ, TZ, UG, ZM, ZW), Eurasian (AM, AZ, BY, KG, KZ, MD, RU, TJ, TM), European (AL, AT, BE, BG, CH, CY, CZ, DE, DK, EE, ES, FI, FR, GB, GR, HR, HU, IE, IS, IT, LT, LU, LV, MC, MK, MT, NL, NO, PL, PT, RO, RS, SE, SI, SK, SM, TR), OAPI (BF, BJ, CF, CG, CI, CM, GA, GN, GQ, GW, ML, MR, NE, SN, TD, TG).
- Published:**
- with international search report (Art. 21(3))
  - before the expiration of the time limit for amending the claims and to be republished in the event of receipt of amendments (Rule 48.2(h))
- (88) **Date of publication of the international search report:**  
7 September 2012

(54) Title: DOWNHOLE RELEASE JOINT WITH RADIALY EXPANDABLE MEMBER

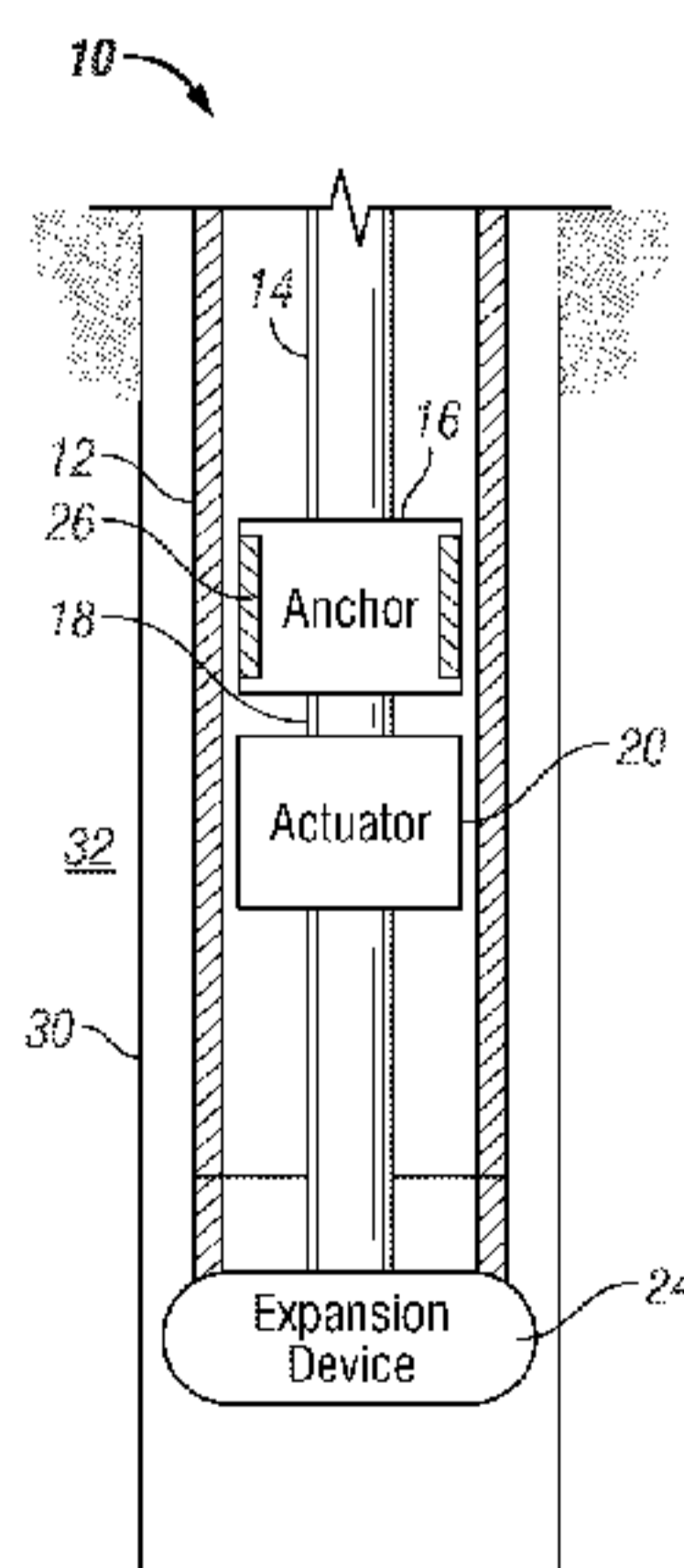

FIG. 1

(57) **Abstract:** An apparatus comprises an expansion device that is coupled to a support member and operable to be disposed within a tubular member. The expansion device is operable to radially expand the tubular member as the expansion device moves axially through the tubular member. A latch assembly is coupled to the support member and is operable to engage a corresponding latch receptacle disposed within the tubular member so as to limit the axial movement of the expansion device relative to the tubular member.

WO 2012/087516 A3

DOWNHOLE RELEASE JOINT  
WITH RADIALY EXPANDABLE MEMBER

BACKGROUND

[0001] This disclosure relates generally to hydrocarbon exploration and production, and in particular to forming well bore tubular strings and connections to facilitate hydrocarbon production or downhole fluid injection.

[0002] During hydrocarbon exploration and production, a well bore typically traverses a number of zones within a subterranean formation. A tubular system may be established in the well bore to create flow paths between the multiple producing zones and the surface of the well bore. Efficient completion of the well bore or production from the surrounding formation is highly dependent on the inner diameter of the tubular system installed in the well bore. Greater inner diameters of the tubular string allows inserted equipment and fluids with appropriate pressure ratings to be used in well completions, while also allowing increased production of hydrocarbons thereafter.

[0003] Expandable tubing may be used to increase the inner diameter of casing, liners and other similar downhole tubular strings used as described above. To create a casing, for example, a tubular member is installed in a well bore and subsequently expanded by displacing an expansion device through the tubular member. The expansion device may be pushed or pulled using mechanical means, such as by a support tubular coupled thereto, or driven by hydraulic pressure. As the expansion device is displaced axially within the tubular member, the expansion device imparts radial force to the inner surface of the tubular member. In response to the radial force, the tubular member plastically deforms, thereby permanently increasing both its inner and outer diameters. In other words, the tubular member expands radially. Expandable tubulars may also be used to repair, seal, or remediate existing casing that has been perforated, parted, corroded, or damaged since installation.

[0004] In some circumstances, after the radial expansion and plastic deformation process, the expansion tools and any other tools associated therewith may need to be removed to the surface of the well bore. Some operations include a separate trip into the well bore, wherein a retrieval tool is lowered and coupled to the expansion tools for retrieval to the surface. In other operations, the upper unexpanded tubular string and the tools coupled thereto are separated from the lower expanded and installed tubular string for removal to the surface. To separate the unexpanded tubular string from the expanded tubular string, a cutter is used. A casing cutter may be part of the initial tool string such that the casing may be cut without an additional trip. However, the cutter operation is time-consuming and creates collateral damage to the casing. It is clear the aforementioned apparatus and methods are problematic.

[0005] The principles of the present disclosure are directed to overcoming one or more of the limitations of the existing apparatus and processes for separating expanded tubing from unexpanded tubing and associated tools.

#### BRIEF DESCRIPTION OF THE DRAWINGS

[0006] For a more detailed description of the embodiments of the present disclosure, reference will now be made to the accompanying drawings, wherein:

[0007] Figure 1 is a fragmentary cross-sectional illustration of an apparatus for installing an expandable tubular member within a preexisting structure;

[0008] Figure 2 is a fragmentary cross-sectional illustration of the apparatus of Figure 1 after displacing the expansion device within the expandable tubular member;

[0009] Figure 3 is a perspective view of an expandable and releasable connection or joint assembly in accordance with principles disclosed herein;

[0010] Figure 4 is a perspective view of the upper tubular member of the releasable joint assembly of Figure 3;

[0011] Figure 5 is a perspective view of the lower tubular member of the releasable joint assembly of Figure 3;

[0012] Figure 6 is a cross-section view of the releasable joint assembly in a coupled position prior to radial expansion by an expansion device;

[0013] Figure 7 is an enlarged portion of Figure 6 showing the connection mechanism between the upper and lower tubular members;

[0014] Figures 8-10 are partial cross-section views showing the releasable joint assembly of Figure 6 during radial expansion, plastic deformation, and release by the expansion device;

[0015] Figures 11 and 12 are alternative embodiments of portions of a releasable joint assembly;

[0016] Figure 13 is a perspective view of an alternative embodiment of a releasable joint assembly in accordance with the principles disclosed herein;

[0017] Figure 14 is a perspective view of the upper tubular member of the releasable joint assembly of Figure 13;

[0018] Figure 15 is a perspective view of the lower tubular member of the releasable joint assembly of Figure 13;

[0019] Figure 16 is a cross-section view of the releasable joint assembly of Figure 13 in a coupled position prior to radial expansion by an expansion device;

[0020] Figure 17 is an enlarged inset of Figure 16 showing the connection mechanism between the upper and lower tubular members;

[0021] Figures 18-23 are partial cross-section views showing the releasable joint assembly of Figures 13, 16 and 17 during radial expansion, plastic deformation, and release by the expansion device.

[0022] Figure 24 is a fragmentary cross-sectional illustration of an apparatus for installing an expandable tubular member within a preexisting structure;

[0023] Figure 25 is a fragmentary cross-sectional illustration of the apparatus of Figure 24 after displacing the expansion device within the expandable tubular member; and

[0024] Figures 26-29 are fragmentary cross-sectional illustrations of one embodiment of a latch assembly engaging with an expandable tubular member.

### DETAILED DESCRIPTION

[0025] In the drawings and description that follow, like parts are typically marked throughout the specification and drawings with the same reference numerals. The drawing figures are not necessarily to scale. Certain features of the disclosure may be shown exaggerated in scale or in somewhat schematic form and some details of conventional elements may not be shown in the interest of clarity and conciseness. The present disclosure is susceptible to embodiments of different forms. Specific embodiments are described in detail and are shown in the drawings, with the understanding that the present disclosure is to be considered an exemplification of the principles of the invention, and is not intended to limit the invention to that illustrated and described herein. It is to be fully recognized that the different teachings of the embodiments discussed below may be employed separately or in any suitable combination to produce desired results.

[0026] In the following discussion and in the claims, the terms “including” and “comprising” are used in an open-ended fashion, and thus should be interpreted to mean “including, but not limited to ...”. Unless otherwise specified, any use of any form of the terms “connect”, “engage”, “couple”, “attach”, or any other term describing an interaction between elements is not meant to limit the interaction to direct interaction between the elements and may also include indirect interaction between the elements described. The terms “pipe,” “tubular member,” “casing” and the like as used herein shall include tubing and other generally cylindrical objects. In addition, in the discussion and claims that follow, it may be sometimes stated that certain components or elements are in fluid communication. By this it is meant that the components are constructed and interrelated such that a fluid could be communicated between them, as via a passageway, tube, or conduit. The various characteristics mentioned above, as well as other features and characteristics described in more detail below, will be readily apparent to those skilled in the art upon reading the

following detailed description of the embodiments, and by referring to the accompanying drawings.

[0027] Referring initially to Figure 1, an embodiment of an expansion apparatus 10 for radially expanding and plastically deforming a tubular member 12 includes a tubular support member 14 that is coupled to an end of an anchor 16 for controllably engaging the tubular member via engaging member 26. Another end of the anchor 16 is coupled to a tubular support member 18 that is coupled to an end of an actuator 20. Another end of the actuator 20 is coupled to a tubular support member 22 that is coupled to an end of an expansion device 24 for radially expanding and plastically deforming the tubular member 12. The anchor 16, the tubular support member 18, the actuator 20, and the tubular support member 22 are positioned within the tubular member 12.

[0028] In one embodiment, the expansion apparatus 10 is positioned within a preexisting structure 30 such as, for example, a wellbore that traverses a subterranean formation 32. Once tubular member 12 and expansion apparatus 10 are disposed at a desired location within structure 30, anchor 16 is activated. The activation of anchor 16 causes engaging member 26 to deform and engage tubular member 12 so as to releasably couple anchor 16 to tubular member 12. As a result, the axial position of anchor 16 is fixed relative to tubular member 12, as shown in Figure 2. Once anchor 16 is releasably coupled to tubular member 12, actuator 20 can be activated to axially displace the expansion device 24 relative to tubular member 12. The axial displacement of expansion device 24 radially expands and plastically deforms a portion of the tubular member 12.

[0029] It is understood that expansion apparatus 10 is only one embodiment of a system utilizing an anchor, actuator, and expansion device and other such systems may be contemplated or are known in the art. Expansion apparatus 10 may also utilize any actuator that provides sufficient force to axially displace the expansion device through the expandable tubular. The actuator may be driven by hydraulic pressure, mechanical forces, electrical power, or any other suitable power source. In alternative embodiments, the expansion device may be a solid mandrel having a fixed outer diameter, an adjustable or collapsible mandrel with a variable outer diameter, a roller-type expansion device, or any other device used to expand a tubular. Such expansion devices may not require an actuator, instead driven by hydraulic pressure or by forces from the drilling rig. Still further, although illustrated in Figure 1 as having an initial position external to the expandable tubular member and configured for upward expansion, in certain embodiments, the expansion device may have an initial position within the tubular and/or be configured for downward expansion. It is also understood that the tubulars that internally receive the expansion apparatus 10 are configured to allow pass-through of the expansion apparatus 10, and radially expand in

response to the enlarged diameter of the expansion apparatus 10 and plastically deform to an enlarged diameter as a result of the expansion apparatus pass-through.

[0030] Referring now to Figure 3, a releasable joint or connection assembly 100 includes an upper tubular member or sub 102 and a lower tubular member or sub 104. In some embodiments, the upper sub 102 is a portion of a tubular string above the assembly 100 and the lower sub 104 is a portion of a tubular string below the assembly 100. In some embodiments, the upper sub 102 is an adapter for coupling with a tubular string above the assembly 100. Likewise, the lower sub 104 may be an adapter for coupling to a lower expandable tubular string. The upper sub 102 includes an upper end 120 and a lower end 122. In some embodiments, the lower end 122 is an increased diameter pin end. The lower sub 104 includes an upper end 130 and a lower end 132. In some embodiments, the upper end 130 is a box end. A connection or coupling 112 is formed between the upper sub 102 and the lower sub 104 at the ends 122, 130, as will be described in further detail below. The arrangement as shown in Figure 3 represents an initial assembled, coupled and deployed position, before substantial interaction with an expansion device.

[0031] Referring to Figure 4, the upper sub 102 includes an inner tapered surface or chamfer 126 and an outer coupling surface 118 at the lower end 122. The coupling surface 118 includes a lower shoulder portion 128, an upper, external shoulder 132, and a threaded portion 131 disposed therebetween. The lower shoulder portion 128 includes an inner, lower shoulder 124. In embodiments where the lower end includes an increased outer diameter, a surface 123 tapers down to the decreased diameter of the main tubular body. In some embodiments, the surface 126 includes a finish. In some embodiments, the finish creates a rough, friction-inducing surface. In some embodiments, the finish includes knurling.

[0032] Referring to Figure 5, the lower sub 104 includes an inner coupling surface 160 at the upper end 130. The coupling surface 160 includes a lower shoulder portion 168, an upper, external shoulder 172, and a threaded portion 170 disposed therebetween. Spaced within the upper end 130 are axial slits 180. The axial slits 180 are circumferentially spaced about the upper end 130 to create separate end portions 181 that may also be referred to as a series of collet fingers forming a collet.

[0033] Referring now to the cross-section views of Figures 6 and 7, the subs 102, 104 are coupled such that their coupling surfaces 118, 160 are engaged to form the threaded connection 112. The collet fingers 181 are in contracted positions relative to each other such that the axial slits 180 are substantially closed off. As shown in the enlarged inset of Figure 7, the subs 102, 104 are threaded together to engage the threaded portions 131, 170 at threaded interface 165. Each thread form of the threaded portion 131 includes a hooked or angled load flank surface facing away from the

lower end 122 that engages a mating hooked or angled load flank surface facing away from the upper end 130 on each thread form of the threaded portion 170 to form a hooked load flank interface 135. Each thread form of the threaded portion 131 also includes a positive or angled stab flank surface facing toward the lower end 122 that engages a mating positive or angled stab flank surface facing toward the upper end 130 on each thread form of the threaded portion 170 to form a positive stab flank interface 175. The hooked load flank angle assists in locking the threads 131, 170 together at coupling or make up of the subs 102, 104. The positive stab flank angle assists in axial relative movement or “jump-in” of the threads 131, 170 during the expand and release process, more fully described below.

[0034] The lower shoulder 124 is disposed adjacent a lower shoulder 154, or engaged with the shoulder 154 to form an internal shoulder interface 140. In some embodiments, the axial load bearing surface of the shoulder 154 is substantially perpendicular to the longitudinal axis of the joint 100 such that the shoulder 154 is a substantially square shoulder. An intermediate shoulder 146 of the sub 102 is disposed adjacent an intermediate shoulder 156 of the sub 104, or engaged with the shoulder 156 to form an intermediate shoulder interface 150. In some embodiments, the axial load bearing surface of the shoulder 156 is angled relative to perpendicular of the longitudinal axis of the joint 100. The direction of the angled shoulder 156, though not necessarily the degree, is similar to that of the positive stab flank angles of the threads 131, 170. The upper shoulder 132 is disposed adjacent the upper shoulder 172. In some embodiments, the shoulders 132, 172 include a slight gap or clearance between them such that they are not actively engaged in the original made up and run-in position of Figures 6 and 7. Thus, a shoulder interface 155 between shoulders 132, 172 may not occur until the expand and release process is underway as explained more fully below. In some embodiments, the shoulders 132, 172 are angled similarly to the positive stab flank angles of the threads 131, 170 in both direction and degree.

[0035] The angled intermediate shoulder 156 may assist in sharing of the compressive loads applied to the joint 100 and accommodate “jump-in” of the threads 131, 170 during the expand and release process. The angled external shoulders 132, 172 may accommodate “jump-in” of the connection 112 during the expand-and-release process. The clearance between the shoulders 132, 172 may also ease the release of the hooked threads 131, 170 during the process. In some embodiments, a clearance is also disposed between the stab flank surfaces of the threads 131, 170 in the original made up and run-in position. During the expand and release process, more fully described below, the clearances between the external shoulders 132, 172 and the stab flanks close to spread and share the compressive loads in the connection 112 and the joint 100.

[0036] During radial expansion and plastic deformation of expandable tubulars by expansion devices as described previously herein, an expansion device expansion device 300 is displaced axially through the expandable tubulars. As shown in Figure 8, the expansion device 300 is axially displaced into the releasable joint assembly 100 and begins to expand the lower sub 104. The expansion device 300 may be displaced by mechanical pulling forces or hydraulic pressure or other means as previously noted herein. Referring to Figure 9, the lead portion of the expansion device 300 is displaced into the connection 112 while the cone portion of the expansion device 300 continues to radially expand the lower sub 104.

[0037] Axial displacement of the device 300 creates compressive forces in the connection 112. Simultaneously, the radially outward forces exerted on the inner surface of the sub 104 cause the axial slits 180 to separate and the collet fingers 181 and the upper end 130 of the lower sub 104 to radially expand. The combination of these forces creates a clearance between the ends 122, 130 and the threads 131, 170 of the connection 112, and relative axial movement between the ends 122, 130. When external shoulder 172 has radially cleared external shoulder 132, the threads 170 have radially cleared the threads 131, the intermediate shoulder 156 has radially cleared the intermediate shoulder 146, and the internal shoulder 154 has radially cleared the internal shoulder 124, as shown in Figure 10, the end 130 of sub 104 “jumps-in” to the end 122 of the sub 102 to a first positive stop position. The first positive stop position is created by axial movement of the external shoulder 132 into engagement with a box counterbore 173, axial movement of the intermediate shoulder 146 into engagement with the internal shoulder 154, and axial movement of the internal shoulder 124 into engagement with an additional step or shoulder 158 disposed below the internal shoulder 154. A second or additional positive stop position may be provided by additional radial clearance and axial movement of the end 132 relative to the end 122, and re-engagement of the intermediate shoulder 146 on the additional step 158 along with corresponding engagements between the external features of the end 122 and the internal features of the end 130.

[0038] As previously noted, the angled shoulders 132, 156, 172 and threads 131, 170 facilitate sharing of the engaged compressive loads and axial “jump-in.” To aid in the positive stop positions of the connection 112, the radial heights  $H_1$  and  $H_2$  of the internal shoulders 156, 154 are substantially similar. Likewise, the axial lengths  $L_1$ ,  $L_2$ , and  $L_3$  of the counterbore 173 and the shoulders 156, 154 are substantially similar.

[0039] Following the one or more positive stop positions, the pin end 122 is de-coupled from the box end 130 and the connection 112 is released. As shown in Figure 10, the chamfer 126 is provided to allow maximum expansion of the box connection 130 before the pin connection 122 begins to radially expand. The increased thickness of the pin end 122 resists radial expansion

forces from the expansion device 300. Furthermore, the surface finish of the chamfer 126, and in some embodiments inner portions of the pin connection 122, increases friction between the pin connection 122 and the expansion device 300. Consequently, the expansion device 300 stops in pin end 122 and upward forces applied to the expansion device 300 and the upper sub 102 will lift these components toward the surface and out of the well while the released lower and expanded sub 104 and associated tubing remain in the well. Prior to removal of the expansion device 300 and sub 102, a positive indication of release is given at the surface of the well detecting a pressure increase.

[0040] In alternative embodiments, one or both of the pin and box ends can be reduced in thickness, such as by eliminating the lowermost shoulders of one or both of these ends. In further alternative embodiments, the pin end can include an increased thickness. In some embodiments, an external sleeve is applied to the pin end to increase its overall thickness. In other embodiments, and as shown in Figure 11, a releasable joint 200 includes an intermediate sleeve 220 captured between box ends 206, 208 of respective subs 202, 204. The coupling is completed with an inner coupling member 210 having pin ends 212, 214 coupled to the respective box ends 206, 208. The lower connection 208, 214 releases as described herein in response to the expansion forces of the device 300. This embodiment may also be referred to as a four-piece releasable connection 200.

[0041] In alternative embodiments, the tapered threads 131, 170 are replaced with straight threads 470 on the box end of a sub 404 as shown in Figure 12. The straight threads 470 increase the thickness of the box end to address certain effects caused by axial compression and radial expansion, such as a banana effect in a cased hole.

[0042] Referring now to Figure 13, an alternative releasable joint or connection assembly 500 includes an upper tubular member or sub 502 and a lower tubular member or sub 504. The upper sub 502 includes an upper end 520 and a lower end 522. In some embodiments, the lower end 522 is an increased diameter pin end. The lower sub 504 includes an upper end 530 and a lower end 533. In some embodiments, the upper end 530 is a box end. A connection or coupling 512 is formed between the upper sub 502 and the lower sub 504 at the ends 522, 530, as will be described in further detail below. The arrangement as shown in Figure 13 represents an initial assembled, coupled and deployed position, before substantial interaction with an expansion device.

[0043] Referring to Figure 14, the upper sub 502 includes an inner tapered surface or chamfer 526 and an outer coupling surface 518 at the lower end 522. The coupling surface 518 includes a lower shoulder portion 528, an upper, external shoulder 532, and a threaded portion 531 disposed therebetween. The lower shoulder portion 528 includes an inner, lower shoulder 524. In embodiments where the lower end

includes an increased outer diameter, a surface 523 tapers down to the decreased diameter of the main tubular body. In some embodiments, the surface 526 includes a finish. In some embodiments, the finish creates a rough, friction-inducing surface. In some embodiments, the finish includes knurling.

[0044] Referring to Figure 15, the lower sub 504 includes an inner coupling surface 560 at the upper end 530. The coupling surface 560 includes a lower shoulder portion 568, an upper, external shoulder 572, and a threaded portion 570 disposed therebetween. Spaced within the upper end 530 are several series of axial slits 580, 582. The axial slits 580 are circumferentially spaced about the upper end 530 to create separate end portions 581 that may also be referred to as a series of collet fingers forming a collet. The axial slits 582 are axially and circumferentially offset from the slits 580. The slits 580, 582 include stress relieving holes 585 as shown. The upper end 530 also includes an outer surface 590 including a first tapered surface 592 and a second tapered surface 594, with a groove or undercut 595 separating the surfaces 592, 594. Adjacent the surface 590 is a surface 597, a portion of which may be tapered.

[0045] Referring now to the cross-section views of Figures 16 and 17, the subs 502, 504 are coupled such that their coupling surfaces 518, 560 are engaged to form the threaded connection 512. The collet fingers 581 are in contracted positions relative to each other such that the axial slits 580 are substantially closed off. Similarly, the offset axial slits 582 are contracted or closed off. As shown in the enlarged inset of Figure 17, the subs 502, 504 are threaded together to engage the threaded portions 531, 570 at threaded interface 565. Each thread form of the threaded portion 531 includes a hooked or angled load flank surface facing away from the lower end 522 that engages a mating hooked or angled load flank surface facing away from the upper end 530 on each thread form of the threaded portion 570 to form a hooked load flank interface 535. Each thread form of the threaded portion 531 also includes a positive or angled stab flank surface facing toward the lower end 522 that engages a mating positive or angled stab flank surface facing toward the upper end 530 on each thread form of the threaded portion 570 to form a positive stab flank interface 575. The hooked load flank angle assists in locking the threads 531, 570 together at coupling or make up of the subs 502, 504, as previously described. The positive stab flank angle assists in axial relative movement or "jump-in" of the threads 531, 570 during the expand and release process, as previously described.

The lower shoulder 524 is disposed adjacent a lower shoulder 554, or engaged with the shoulder 554 to form an internal shoulder interface 540. An intermediate shoulder 546 of the sub 502 is disposed adjacent an intermediate shoulder 556 of the sub 504, or engaged with the shoulder 556 to form an intermediate shoulder interface 550. The upper shoulder 532 is disposed adjacent the upper shoulder 572. In some embodiments, the shoulders 532, 572 include a slight gap or

clearance between them such that they are not actively engaged in the original made up and run-in position of Figures 16 and 17. Thus, a shoulder interface 555 between shoulders 532, 572 may not occur until the expand and release process is underway as explained more fully below. In some embodiments, the shoulders 532, 572 are angled.

[0047] During radial expansion and plastic deformation of expandable tubulars by expansion devices as described previously herein, an expansion device expansion device 300 is displaced axially through the expandable tubulars. As shown in Figure 18, the expansion device 300 is axially displaced into the releasable joint assembly 500 and begins to expand the lower sub 504. The expansion device 300 may be displaced by mechanical pulling forces or hydraulic pressure or other means as previously noted herein. Referring to Figure 19, the lead portion of the expansion device 300 is displaced into the connection 512 while the cone portion of the expansion device 300 continues to radially expand the lower sub 504.

[0048] Still referring to Figure 19 and the enlarged inset of Figure 20, axial displacement of the device 300 creates compressive forces in the connection 512. Simultaneously, the radially outward forces exerted on the inner surface of the sub 504 cause the end 530 with the collets 581 to expand radially outward. As shown in Figure 20, the end 530 with collets 581 begins to separate from the end 522. Consequently, the threaded portions 531, 570 begin to separate or release. The angled threads 531, 570 and the angled shoulders as described with reference to Figure 17 may assist with relative jump-in of the end 522 of the sub 502 and the end 530 of the sub 504 as previously described. The angled interfaces of the coupling surfaces 518, 560 may assist in sharing compressive loads and enhance relative movement of the threads and shoulders to one or more positive stop positions, as also previously described. Similarly, in certain embodiments, the radial heights of the internal shoulders are substantially the same while the axial lengths of the shoulders are also substantially the same.

[0049] Referring now to Figures 21-23, the end 522 is de-coupled from the box end 530 and the connection 512 is released. As shown in Figure 22, the threaded portions 531, 570 are released and the collets 581 are expanded outwardly due to the separation at the axial slits 580 that results in the expansion gap 583. The increased thickness of the pin end 522 resists radial expansion forces from the expansion device 300, while certain other features as described herein increase friction between the pin connection 522 and the expansion device 300. Consequently, the expansion device 300 stops in pin end 522 and upward forces applied to the expansion device 300 and the upper sub 502 will lift these components toward the surface and out of the well while the released lower and expanded sub 504 and associated tubing remain in the well, as shown in Figure 23. The

radially expanded box end 530 also includes expanded slits 582 and deformed stress relieving holes 585, as well as the expansion gaps 583 in the slits 580.

[0050] The assembled and deployed releasable joint assembly 100 can be coupled into upper and lower tubing strings using the upper and lower pipe subs 102, 104, respectively. When a lower tubing string is radially expanded and plastically deformed, such as with tubular member 12 in Figures 1 and 2, eventually the expansion device 24, 300 engages the lower end of the lower sub 104, as is shown in Figure 8. The position in the tubing string of the releasable joint assembly 100 can be predetermined, for example, based on the desired quantity or length of the lower expanded tubing 12. Then the expansion device 300 is axially displaced through the lower sub 104. As the tapered expansion surfaces of the expansion cone 300 exert radially outward forces on the inner surface of the sub 104, the lower portion of the sub 104 becomes radially expanded and plastically deformed. The radial expansion forces are then applied to the releasable joint assembly 100 to release the threaded connection. The upper and lower tubing strings are then released and separated. The releasable joint assembly 500 as described above can also be used in the same manner.

[0051] Referring now to Figure 24, an embodiment of an expansion apparatus 610 for radially expanding and plastically deforming a tubular member 612. Tubular member 612 includes release joint 634 and latch receptacle 636. Expansion apparatus 610 comprises a tubular support member 614 that is coupled to an end of an anchor 616 for controllably engaging the tubular member via engaging member 626. Another end of the anchor 616 is coupled to a tubular support member 618 that is coupled to an end of an actuator 620. Another end of the actuator 620 is coupled to a support member 622 that is coupled to an end of an expansion device 624 for radially expanding and plastically deforming the tubular member 612. Latch assembly 628 is disposed on support member 622 between expansion device 624 and actuator 620.

[0052] In one embodiment, the expansion apparatus 610 is positioned within structure 30 that traverses a subterranean formation 632. Once tubular member 612 and expansion apparatus 610 are disposed at a desired location within structure 30, anchor 616 is activated. The activation of anchor 616 cause member 626 to engage tubular member 612 so as to releasably couple anchor 616 to tubular member 612. As a result, the axial position of anchor 616 is fixed relative to tubular member 612, as shown in Figure 25. Once anchor 616 is releasably coupled to tubular member 612, actuator 620 can be activated to axially displace the expansion device 624 relative to tubular member 612. The axial displacement of expansion device 624 radially expands and plastically deforms a portion of the tubular member 612.

[0053] Once actuator 620 has moved expansion device 624, anchor 616 can be released from tubular member 612. Anchor 616 and actuator 620 are then displaced through tubular member 612 so that the cycle can be repeated. As expansion device 624 expands release joint 634, the unexpanded portion of tubular member 612 releases from the expanded portion and latch assembly 628 engages latch receptacle 636. This engagement couples expansion apparatus 610 to the unexpanded portion of tubular member 612, which stops the expansion process and allows the expansion apparatus and unexpanded tubular member to be removed from wellbore 630.

[0054] In certain embodiments, the engagement of latch assembly 628 and latch receptacle 636 may prevent both rotational and axial movement of expansion apparatus 610 relative to tubular member 612. Once latch assembly 628 is engaged with latch receptacle 636, expansion device 624 and latch assembly 628 may be disconnected from expansion apparatus 610. This allows the remainder of the expansion apparatus to be retrieved from wellbore 630 separately from the unexpanded tubular member 612.

[0055] Figures 26-29 illustrate the interaction of latch assembly 628 and latch receptacle 636 in tubular member 612. Latch assembly 628 comprises dogs 640 disposed within latch housing 644. Springs 642 are disposed between dogs 640 and housing 644 and bias dogs outward into contact with tubular member 612. Latch assembly 628 comprises a plurality of dogs 640 spaced circumferentially around latch housing 644. The size and number of dogs 640 is determined based on the diameter of latch assembly 628 and the forces expected during operation.

[0056] In certain embodiments, dogs 640 include tapered leading edge 646, tapered trailing edge 648, and an engagement slot 650. Latch receptacle 636 has a protruding ledge 652 that is disposable within engagement slot 650. In certain embodiments, protruding ledge 652 may comprise torque shoulders 654 that are operable to engage the sides of dogs 640 and limit rotational movement of latch assembly 628 relative to tubular member 612. Torque shoulders 654 and ledge 652 may be arranged so that rotational movement of latch assembly 628 relative to tubular member 612 is only limited when the latch assembly is in a selected longitudinal position relative to the tubular member. For example, in certain embodiments torque shoulders 654 engage when latch assembly 628 is moved downward relative to tubular member 612 and disengage when the latch assembly is moved upward relative to the tubular member.

[0057] Figure 26 illustrates latch assembly 628 approaching latch receptacle 636. Springs 642 are partially compressed, maintaining contact between dog 640 and tubular member 612. The compressibility of springs 642 and the tapered edges 646, 648 allow dog 640 to pass through obstructions within tubular member 612. As dog 640 moves into engagement with latch receptacle 636, as is shown in Figure 27, springs 642 urge the dog outward and into the receptacle. The

engagement of ledge 652 and slot 650 limits the movement of latch assembly 628 upward relative to tubular member 612, as is shown in Figure 28, and downward, as is shown in Figure 29.

[0058]

[0059] In various embodiments described herein, a downhole releasable tubing connection includes a joint between two tubing strings, wherein one of the two tubing strings is radially expanded and plastically deformed by an expansion device. When the expansion device is moved adjacent to the joint, a mechanism in the joint reacts to the radially outward forces of the expansion device and releasably expands, separates, and provides a release between the two tubing strings. One tubing string and the expansion device can then be removed to the surface of the well bore while the expanded tubing remains installed in the well bore. The two tubular members of the releasable tubing connection may be coupled by threads, and the threads may be releasable in response to radial expansion by a collet mechanism.

[0060] While the disclosure is susceptible to various modifications and alternative forms, specific embodiments thereof are shown by way of example in the drawings and description.

**CLAIMS**

1. An apparatus comprising:

a support member operable to be disposed within a tubular member having a first portion and a second portion;

an expansion device coupled to said support member and operable to radially expand the first portion of the tubular member as said expansion device moves axially through the first portion of the tubular member;

a release joint that couples the first portion of the tubular member to the second portion of the tubular member and releases the first portion of the tubular member from the second portion of the tubular member when the release joint is radially expanded by the expansion device;

a latch receptacle disposed within the second portion of the tubular member; and

a latch assembly coupled to said support member and operable to engage the latch receptacle as the first portion of the tubular member is released from the second portion of the tubular member, wherein the engagement of the latch assembly and the latch receptacle limits axial movement of said expansion device relative to the second portion of the tubular member.

2. The apparatus of claim 1, further comprising:

an anchor coupled to said support member and operable to selectively engage the tubular member; and

an actuator coupled to said support member and operable to move said expansion device axially relative to said anchor.

3. The apparatus of claim 1 wherein said latch assembly further comprises:

a latch housing coupled to said support member;

a plurality of dogs disposed within said latch housing; and

one or more biasing members operable to bias said plurality of dogs outward into contact with the tubular member.

4. The apparatus of claim 3 wherein each of said plurality of dogs comprises a slot operable to engage a ledge disposed within the latch receptacle.
5. The apparatus of claim 1 wherein the engagement of said latch assembly and the latch receptacle limits rotational movement of said support device relative to the second portion of the tubular member.
6. A system comprising:
  - a first tubular member;
  - a second tubular member;
  - a releasable connection coupling the first tubular member to the second tubular member;
  - a latch receptacle disposed within the second tubular member;
  - an expansion device coupled to a support member and operable to radially expand the first tubular member as said expansion device moves axially through the first tubular member; and
  - a latch assembly coupled to said support member and operable to engage said latch receptacle as the expansion device moves axially through the releasable connection so as to limit the axial movement of said expansion device relative to the second tubular member.
7. The system of claim 6, further comprising:
  - an anchor coupled to said support member and operable to selectively engage the first and second tubular members; and
  - an actuator coupled to said support member and operable to move said expansion device axially relative to said anchor.
8. The system of claim 6, wherein said releasable connection is operable to release said first tubular member from said second tubular member as the releasable connection is radially expanded by said expansion member.

9. The system of claim 6, wherein said latch assembly further comprises:  
a latch housing coupled to said support member;  
a plurality of dogs disposed within said latch housing; and  
one or more biasing members operable to bias said plurality of dogs outward into contact with the second tubular member.
10. The system of claim 9 wherein each of said plurality of dogs comprises a slot operable to engage a ledge disposed within the latch receptacle.
11. The system of claim 6 wherein the engagement of said latch assembly and the latch receptacle limits rotational movement of said expansion device relative to the second tubular member.
12. A method comprising:  
forming a tubular member by coupling a first tubular portion to a second tubular portion with a releasable connection;  
disposing the tubular member in a wellbore, wherein the second portion of the tubular member includes a latch receptacle;  
disposing an expansion apparatus in the first portion of the tubular member, wherein the expansion apparatus includes an expansion member and a latch assembly disposed on a support member;  
axially displacing the expansion device through the tubular member so as to radially expand the first portion of the tubular member; and  
engaging the latch receptacle with the latch assembly so as to limit the axial displacement of the expansion apparatus through the tubular member.
13. The method of claim 12, wherein engaging the latch receptacle and the latch assembly limits the rotational movement of the expansion apparatus relative to the tubular member.

14. The method of claim 12, wherein the expansion apparatus further includes an anchor coupled to the support member and operable to selectively engage the tubular member; and an actuator coupled to the support member and operable to axially displace the expansion device relative to the anchor.
15. The method of claim 14, wherein the expansion device is axially displaced through the tubular member by activating the anchor and actuator.
16. The method of claim 12, wherein the releasable connection is released by the expansion device.
17. The method of claim 16, further comprising:  
releasing the first tubular member from the second tubular member prior to the latch assembly engaging the latch receptacle.
18. The method of claim 17, further comprising:  
removing the first tubular member and the expansion apparatus from the wellbore.
19. The method of claim 12, further comprising:  
separating the second portion of the tubular member from the first portion of the tubular member, wherein the latch receptacle is disposed in the second portion of the tubular member; and  
removing the second portion of the tubular member and the expansion apparatus from the wellbore.

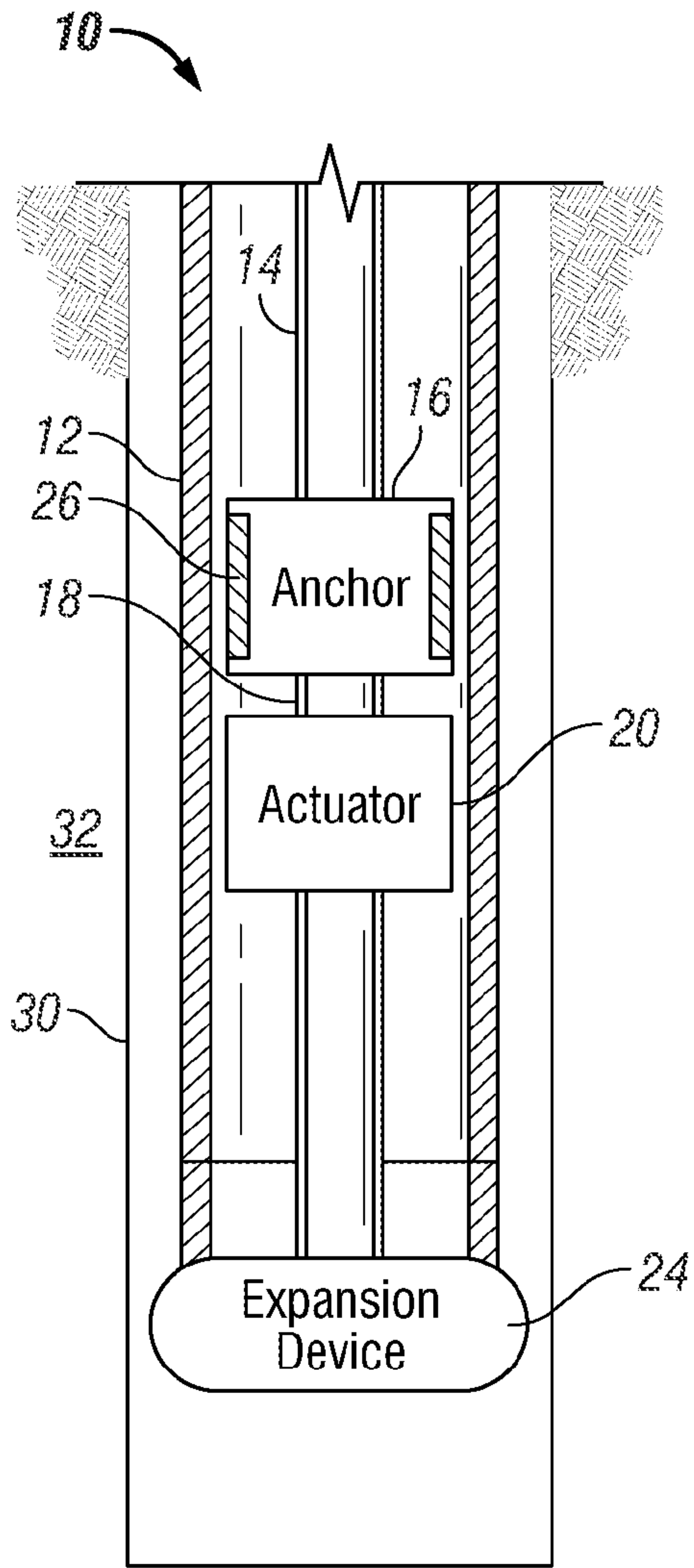

FIG. 1

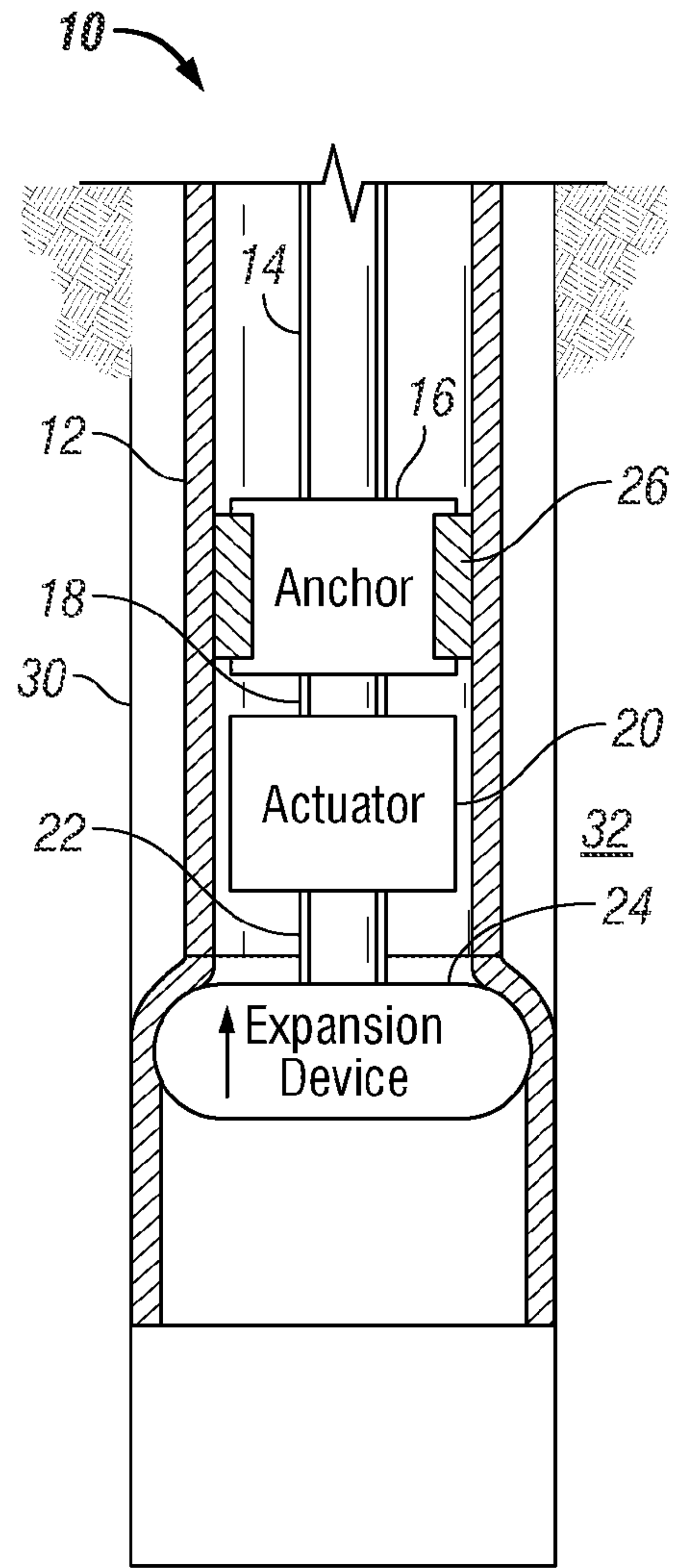

FIG. 2

2/18

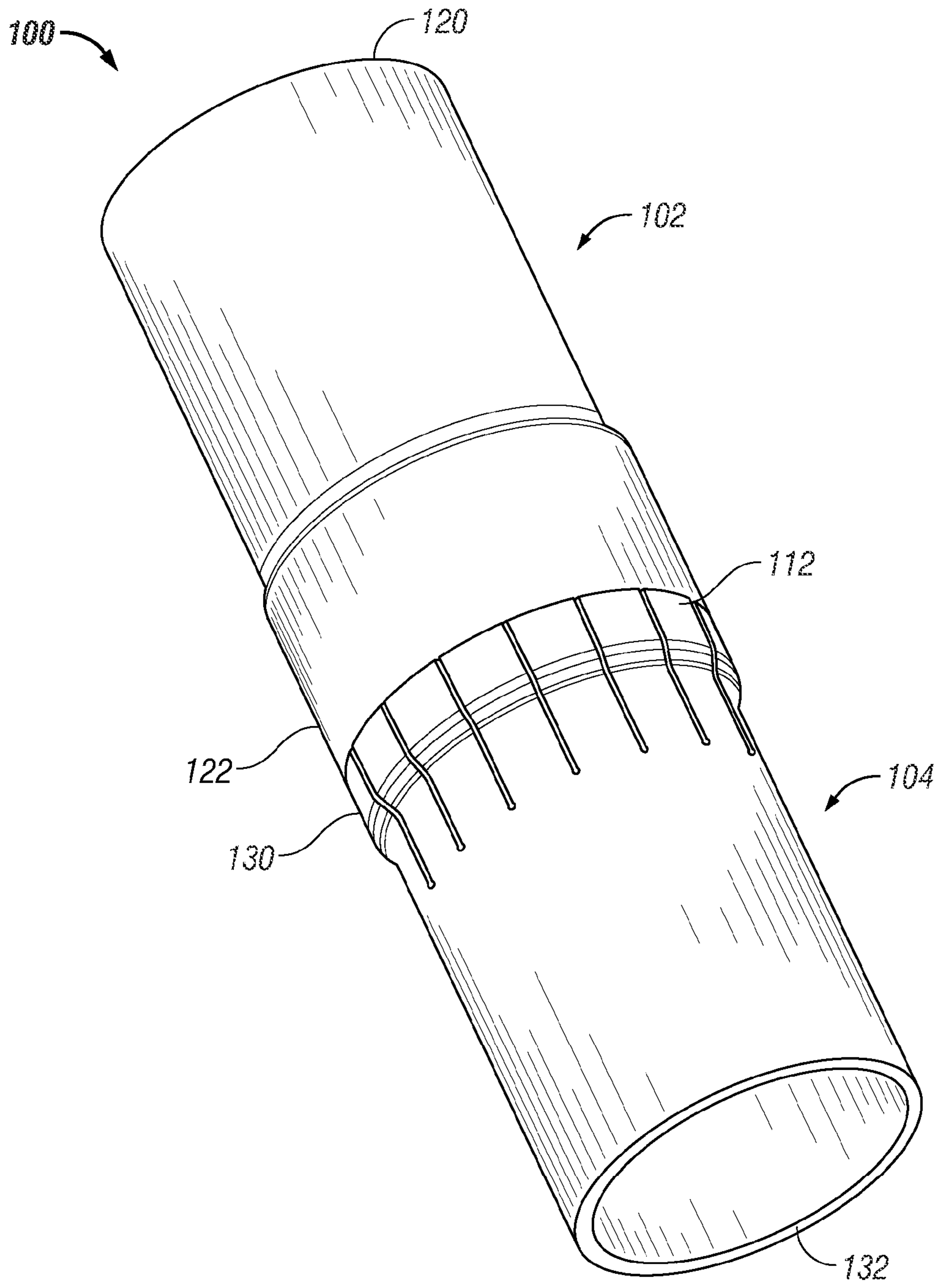

FIG. 3

3/18

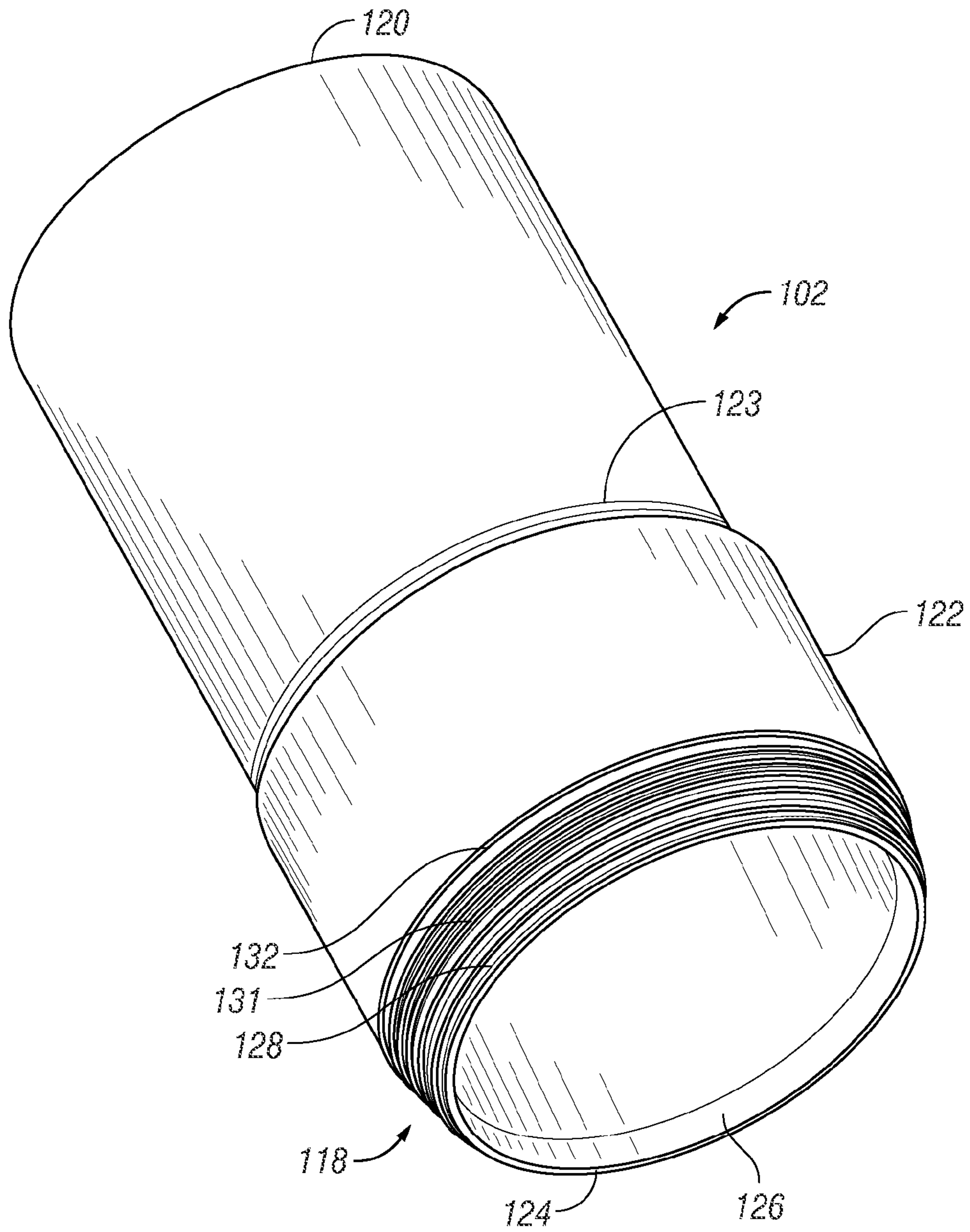

FIG. 4

4/18

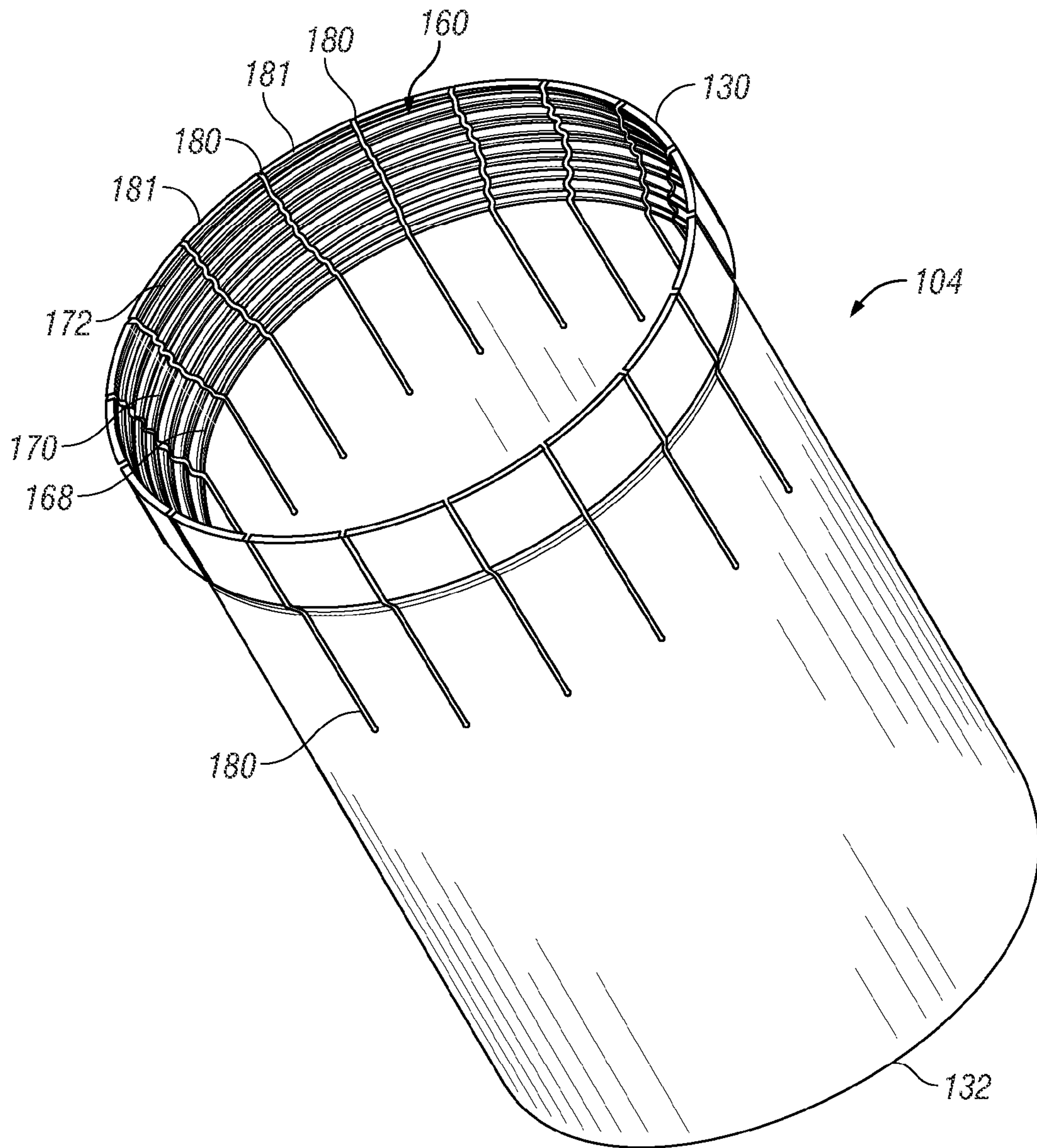

FIG. 5

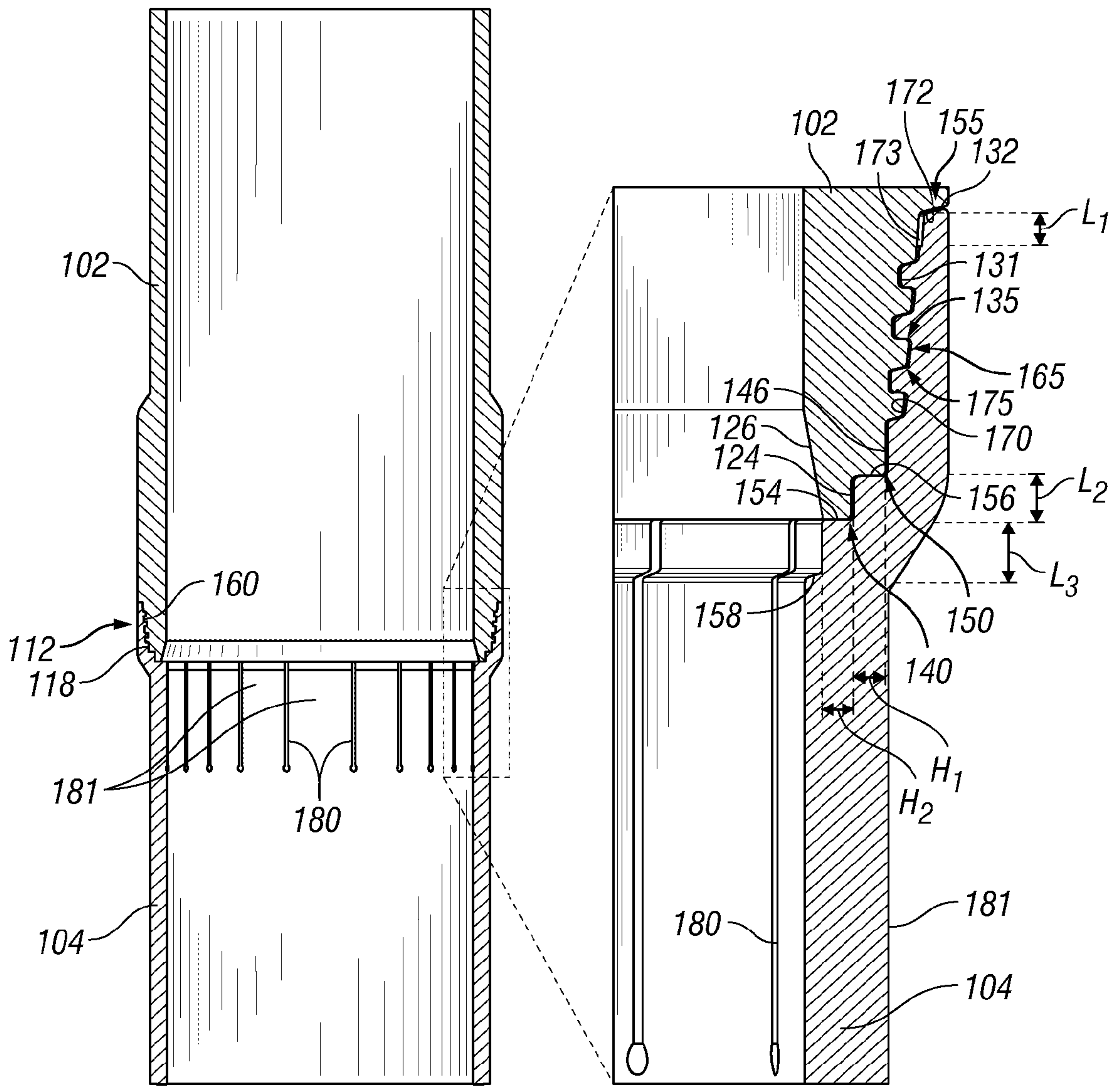

FIG. 6

FIG. 7

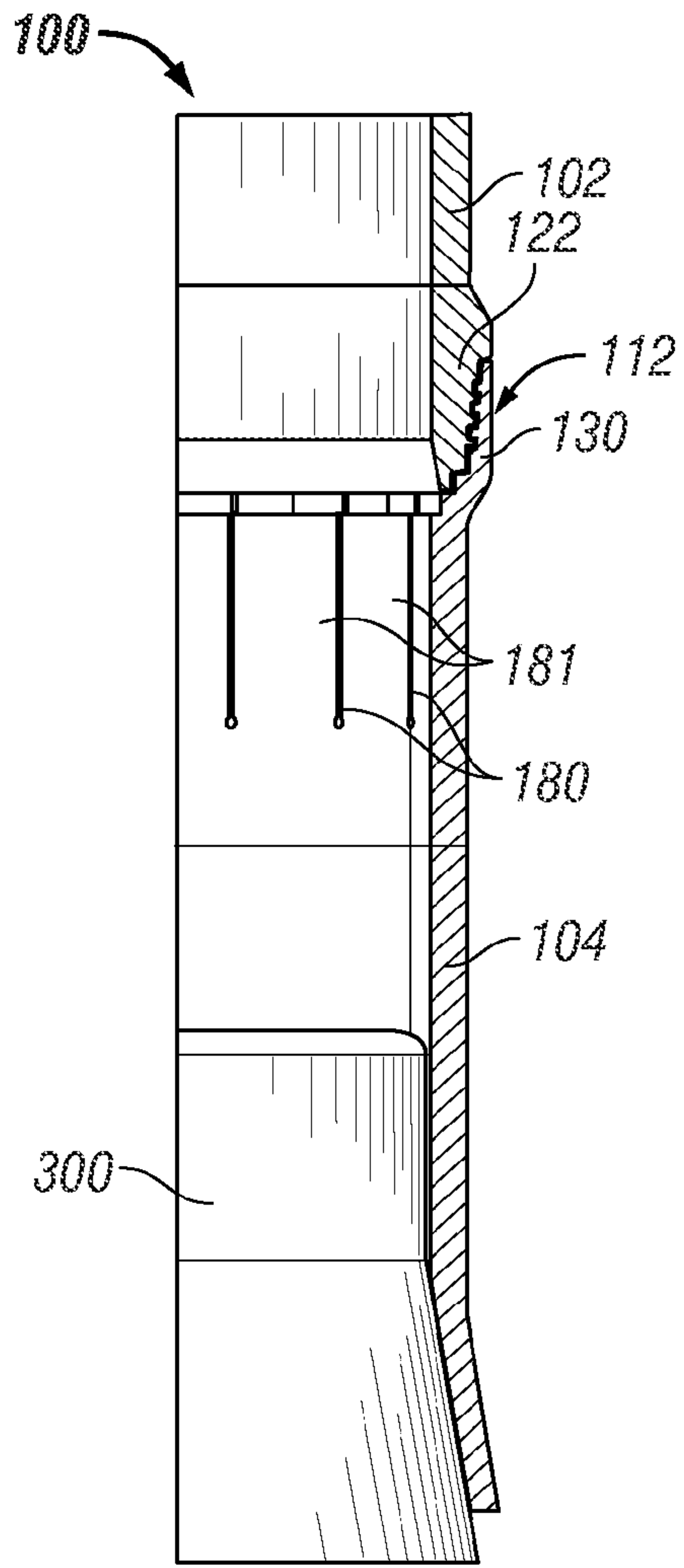

FIG. 8

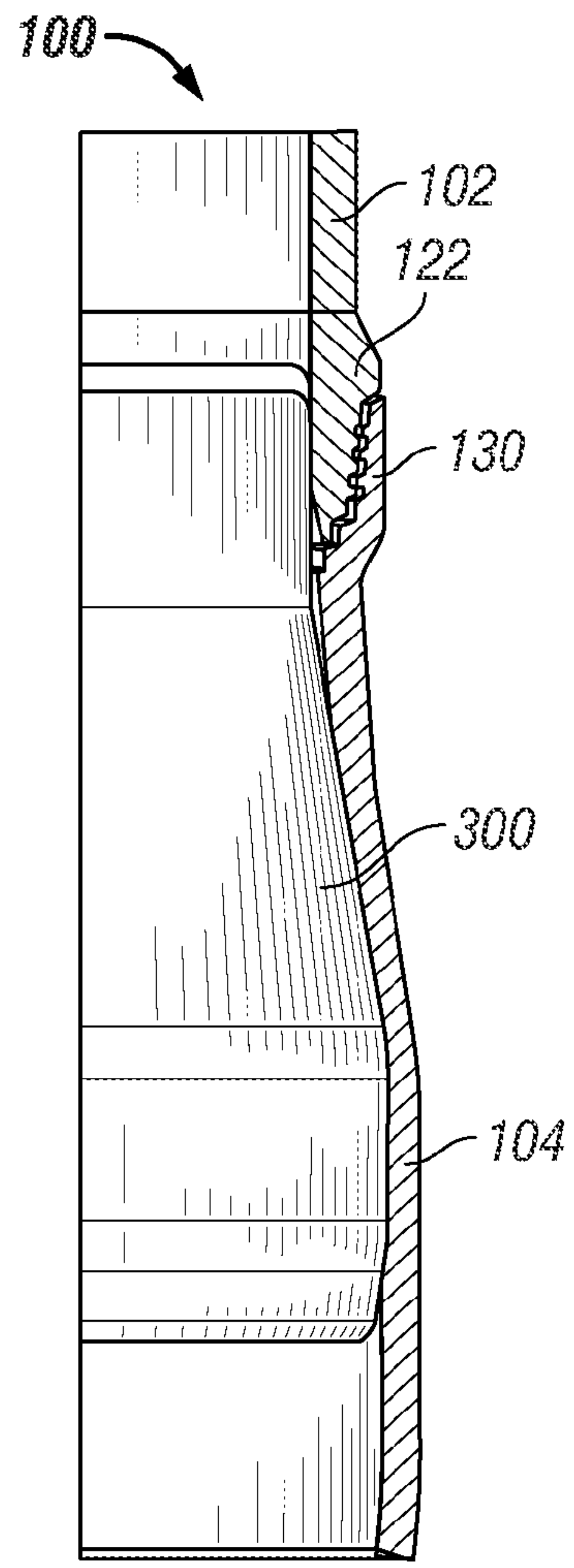

FIG. 9

7/18

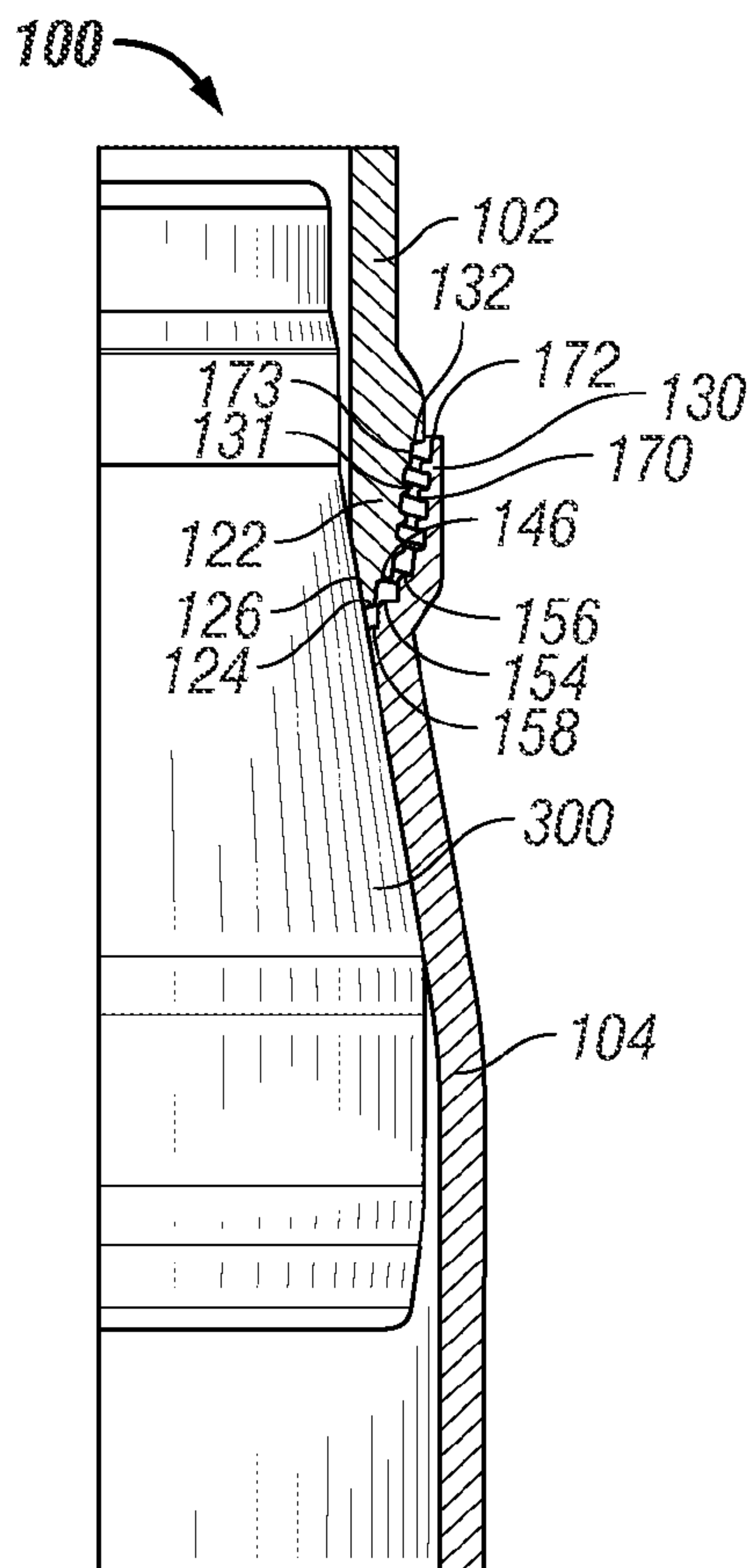

FIG. 10

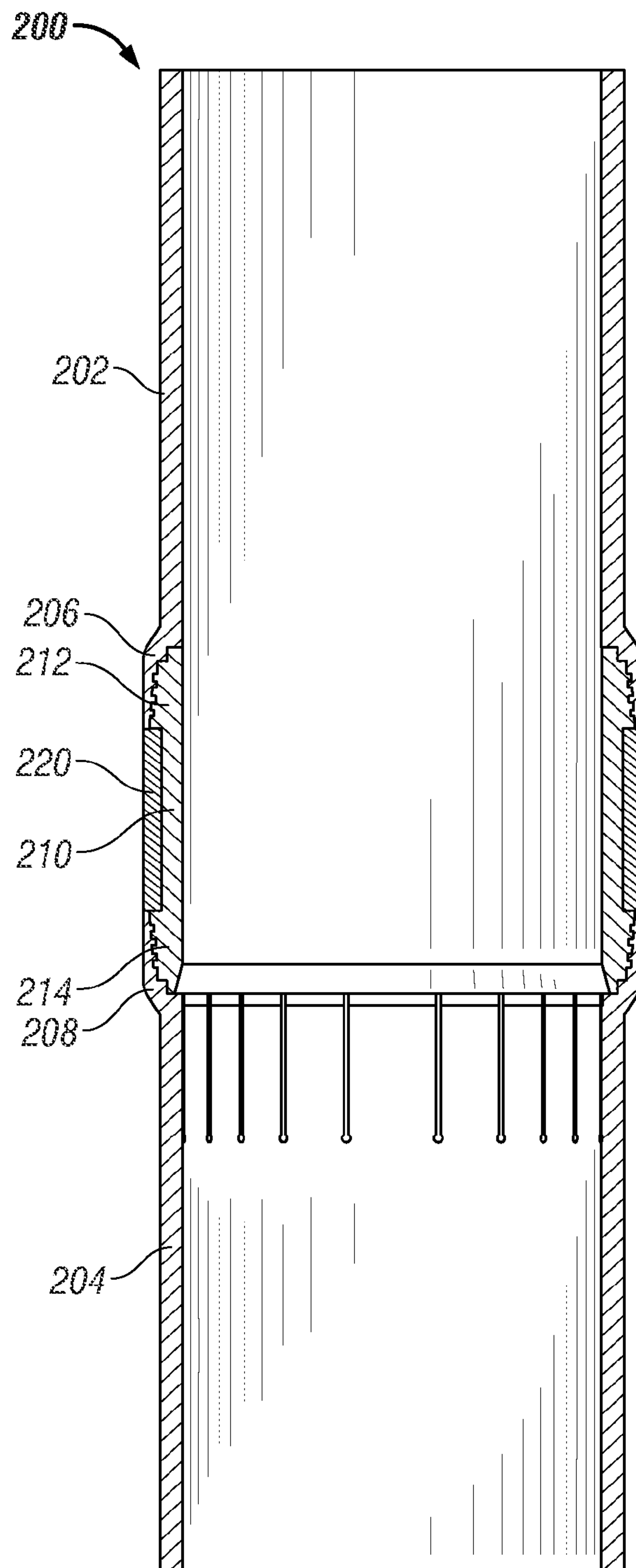

FIG. 11

9/18

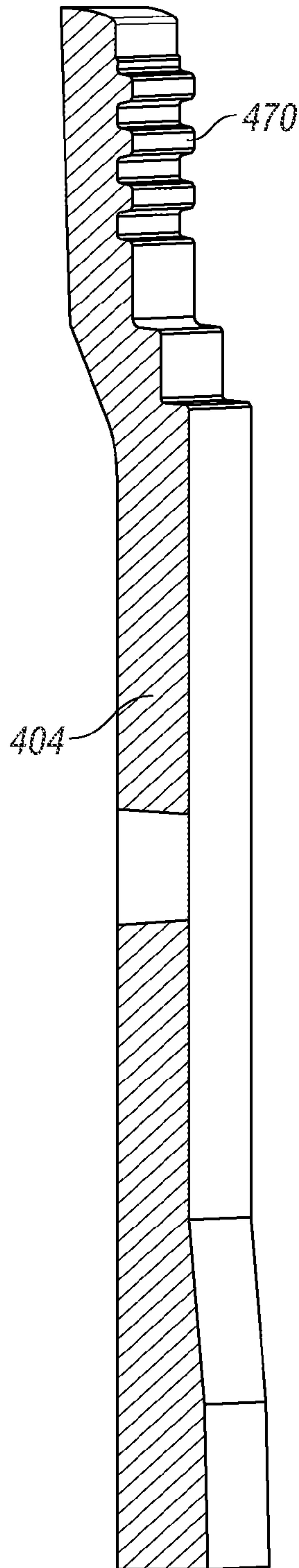

FIG. 12

10/18  
Replacement Sheet

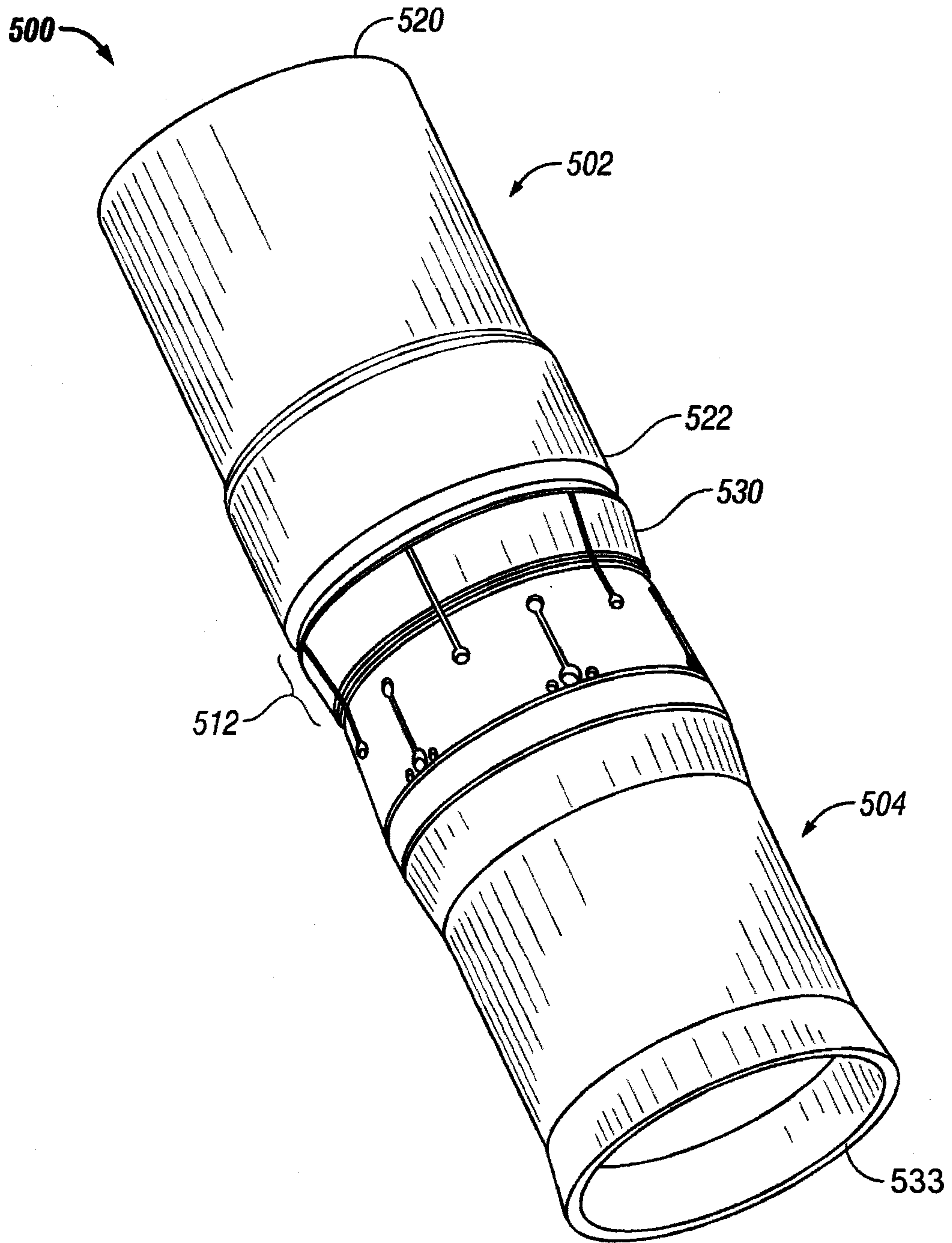

FIG. 13

11/18

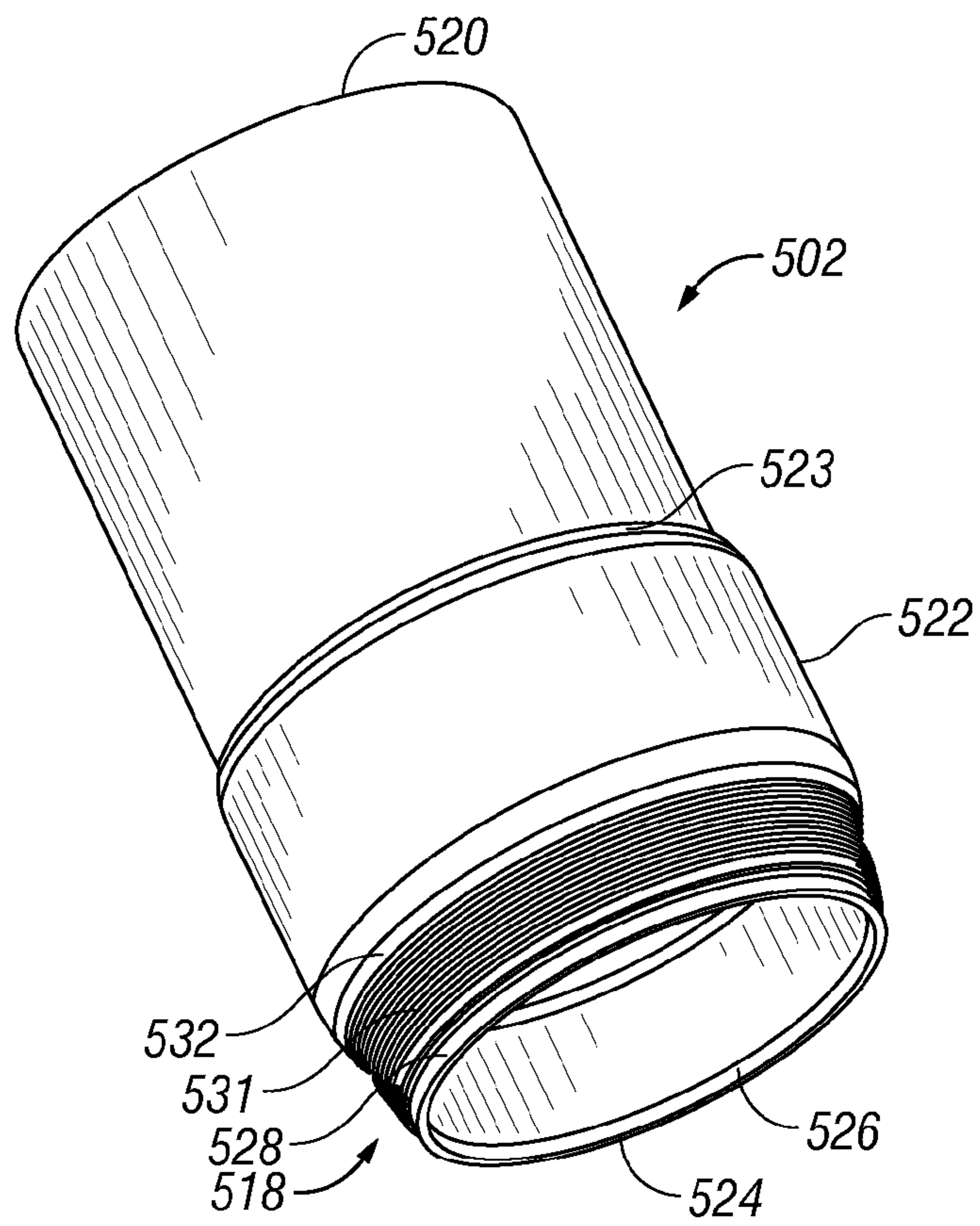

FIG. 14

12/18  
Replacement Sheet

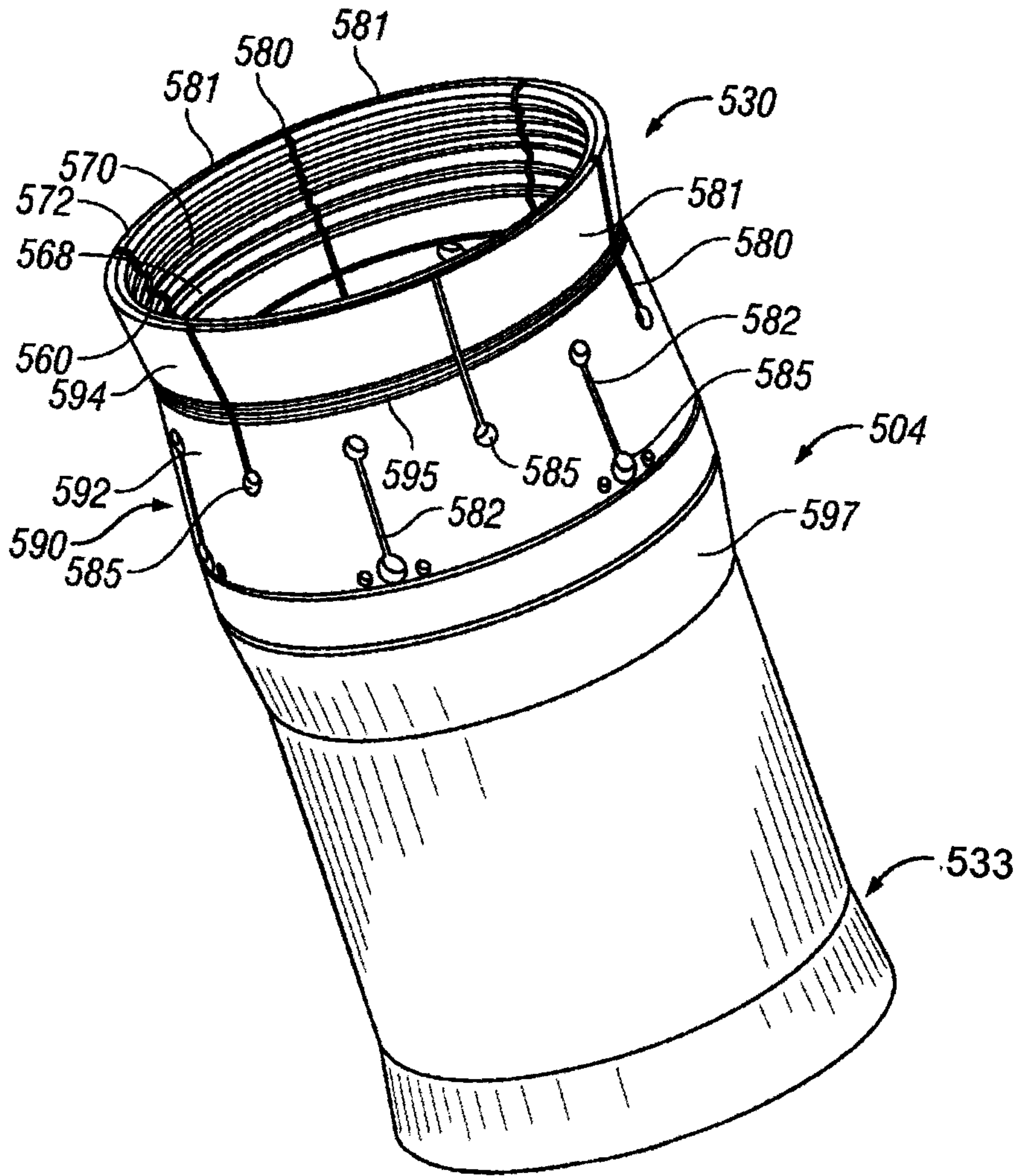

FIG. 15

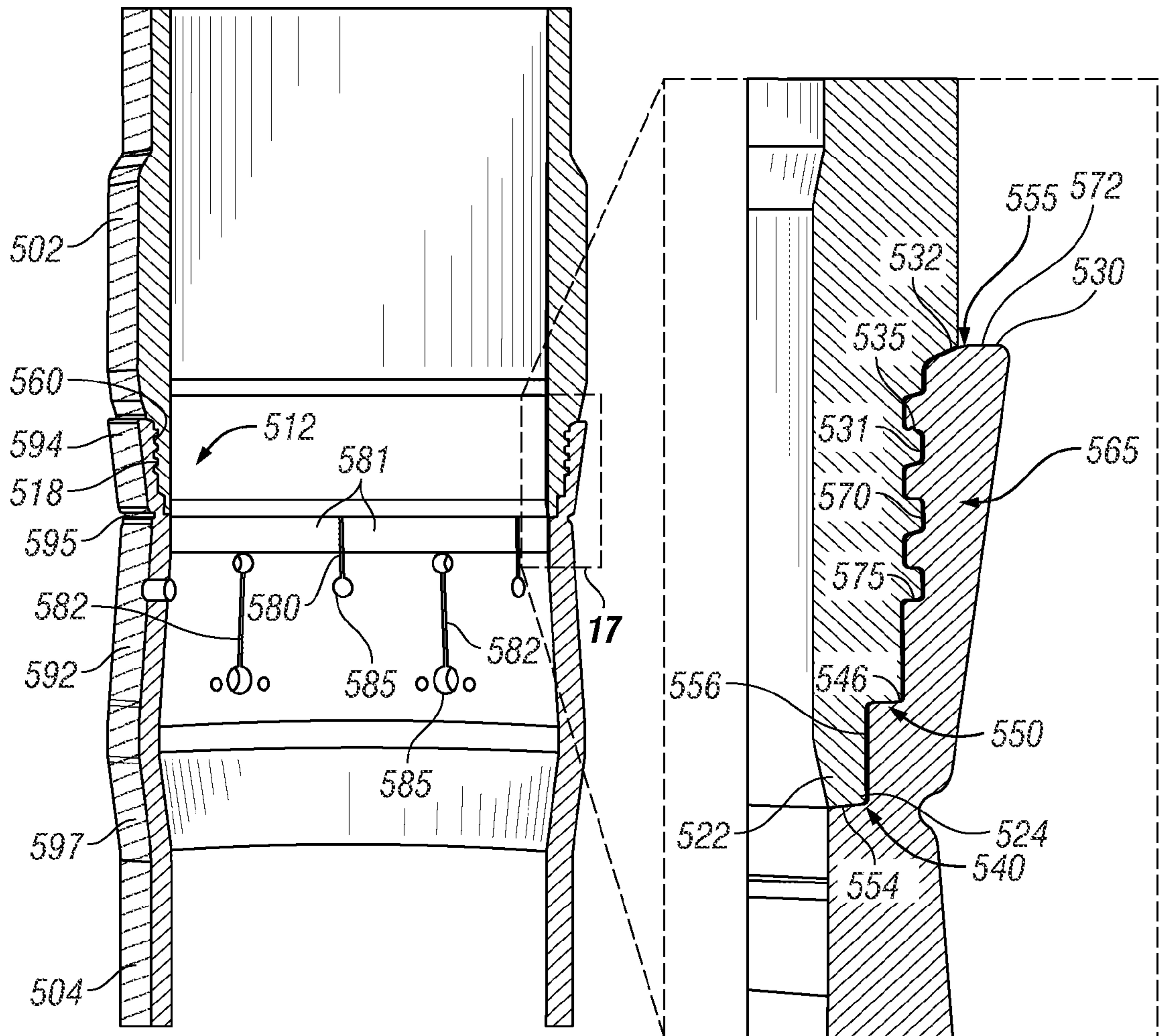

FIG. 16

FIG. 17

14/18

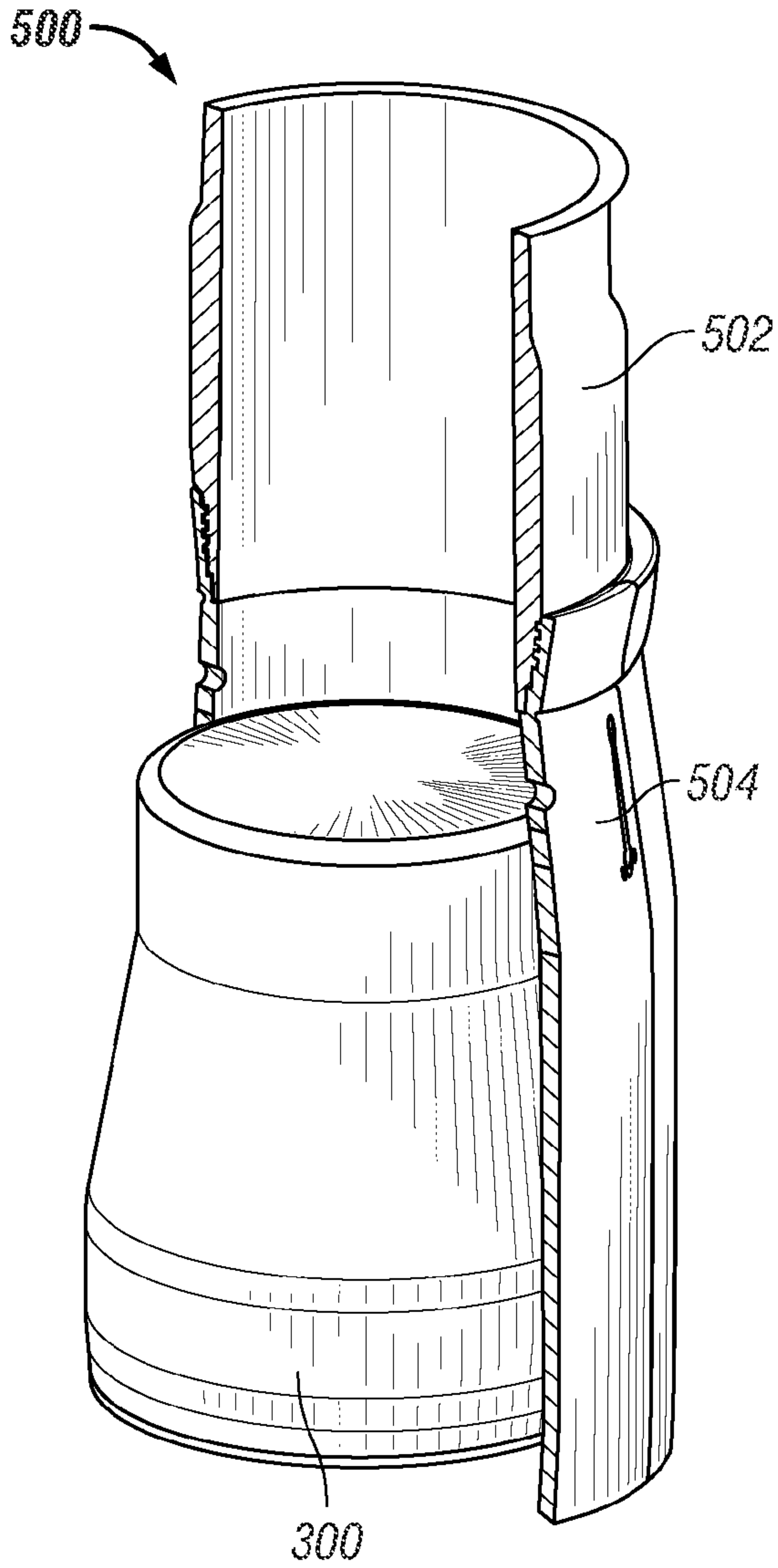

FIG. 18

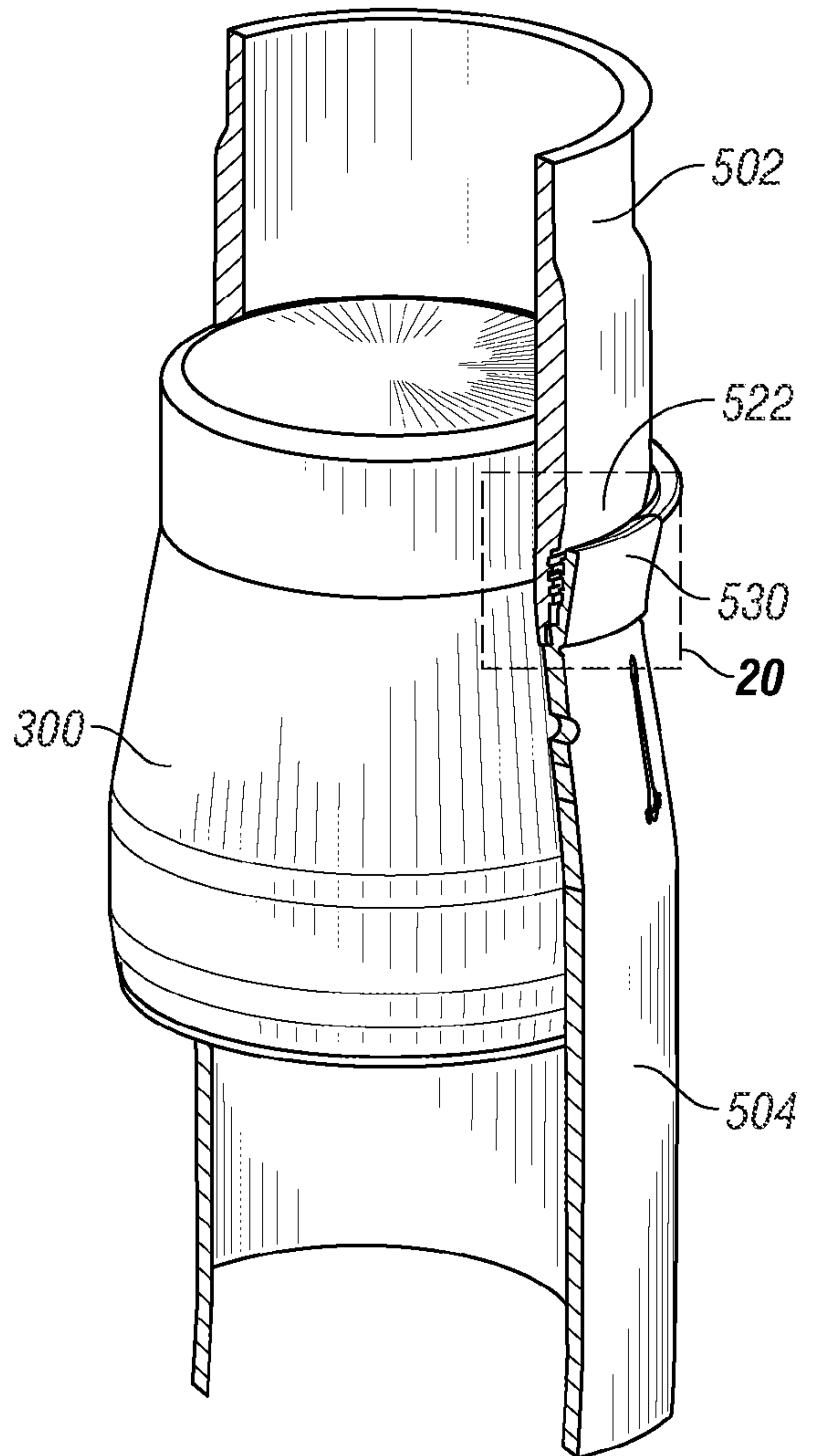

FIG. 19

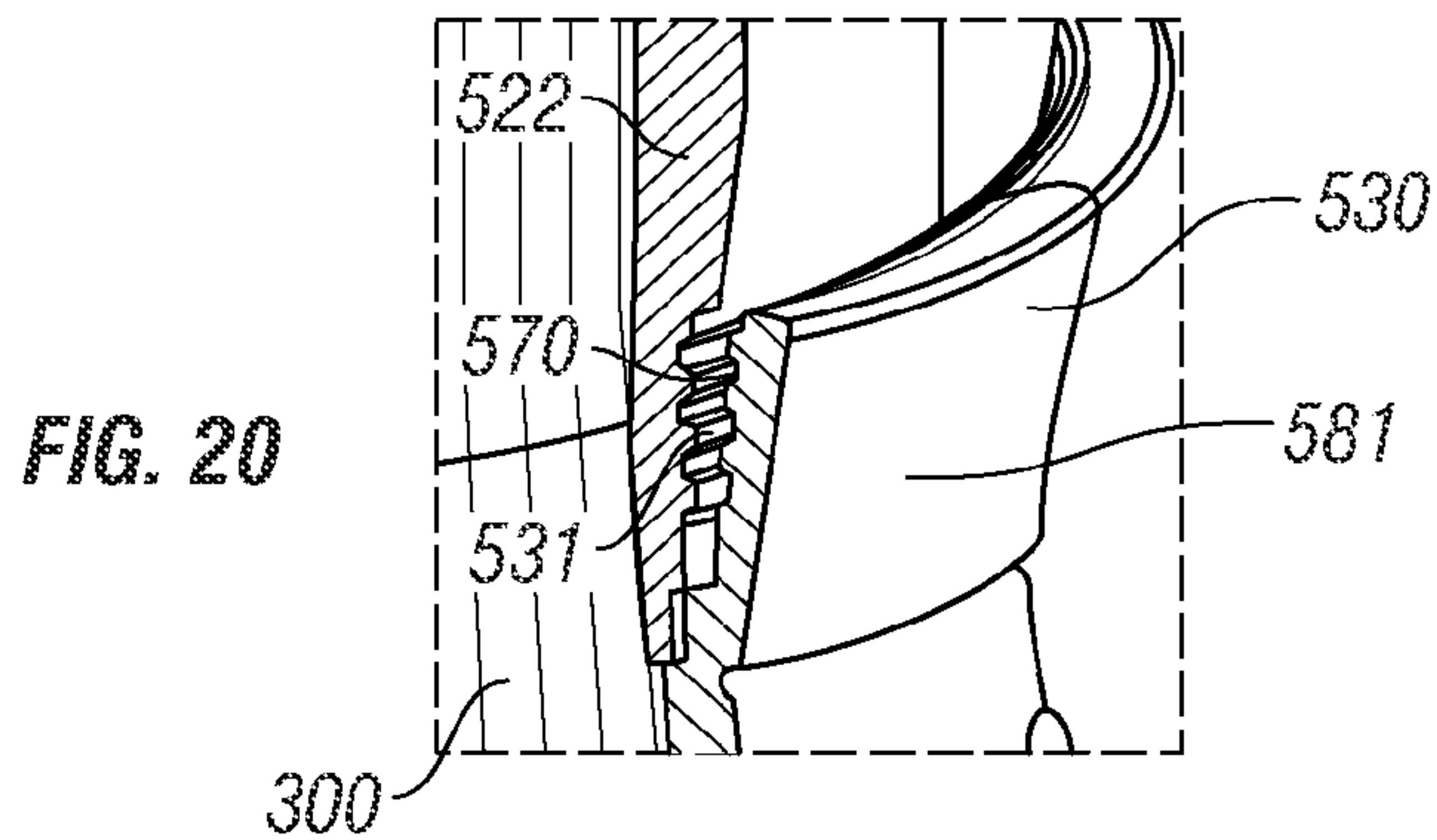

FIG. 20

15/18

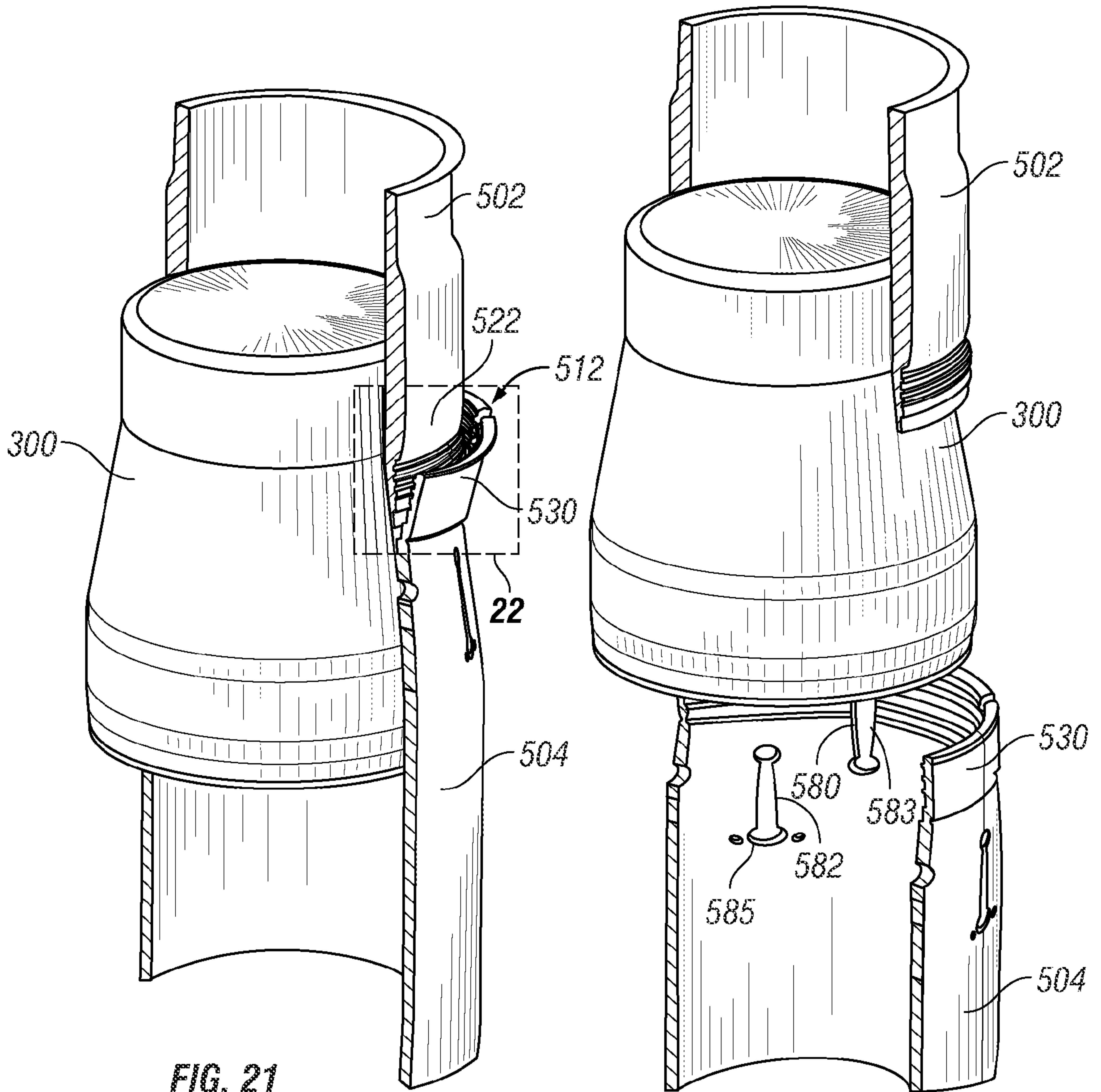

FIG. 21

FIG. 23

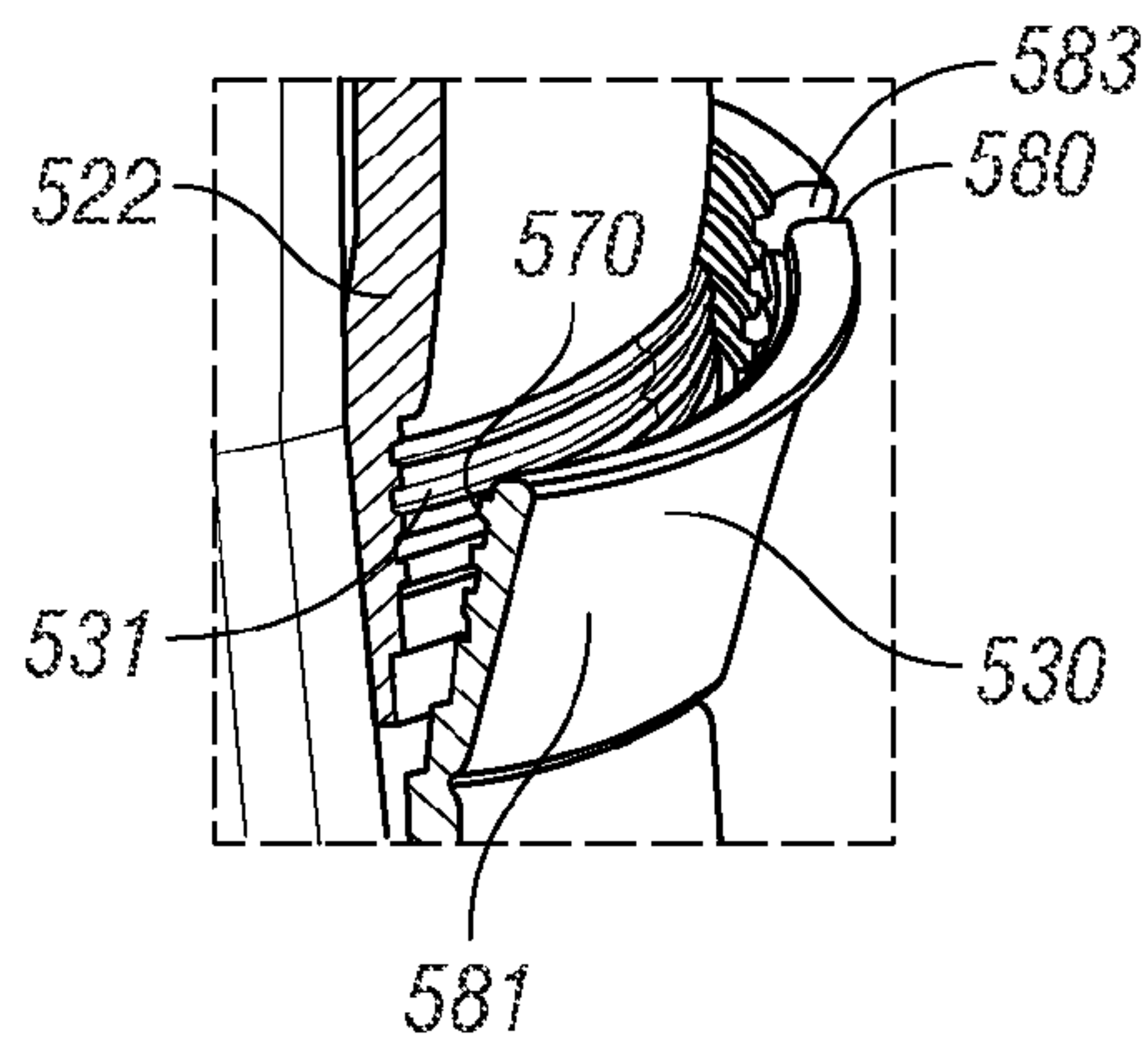

FIG. 22

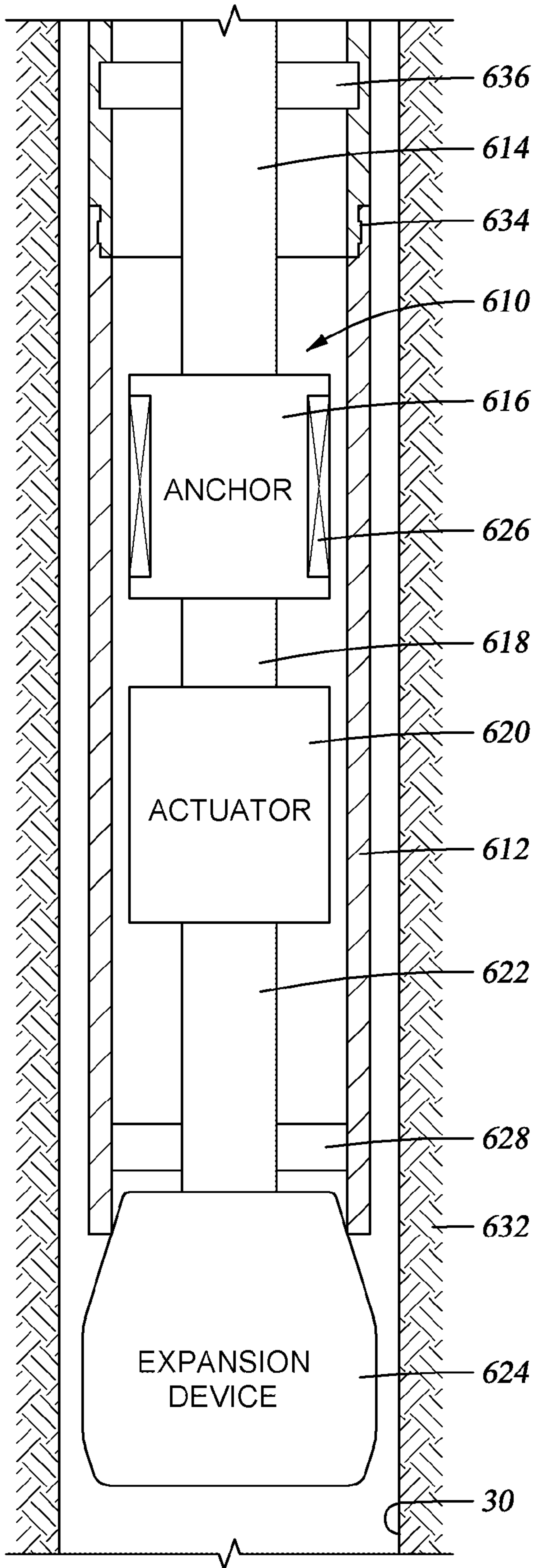

Fig. 24

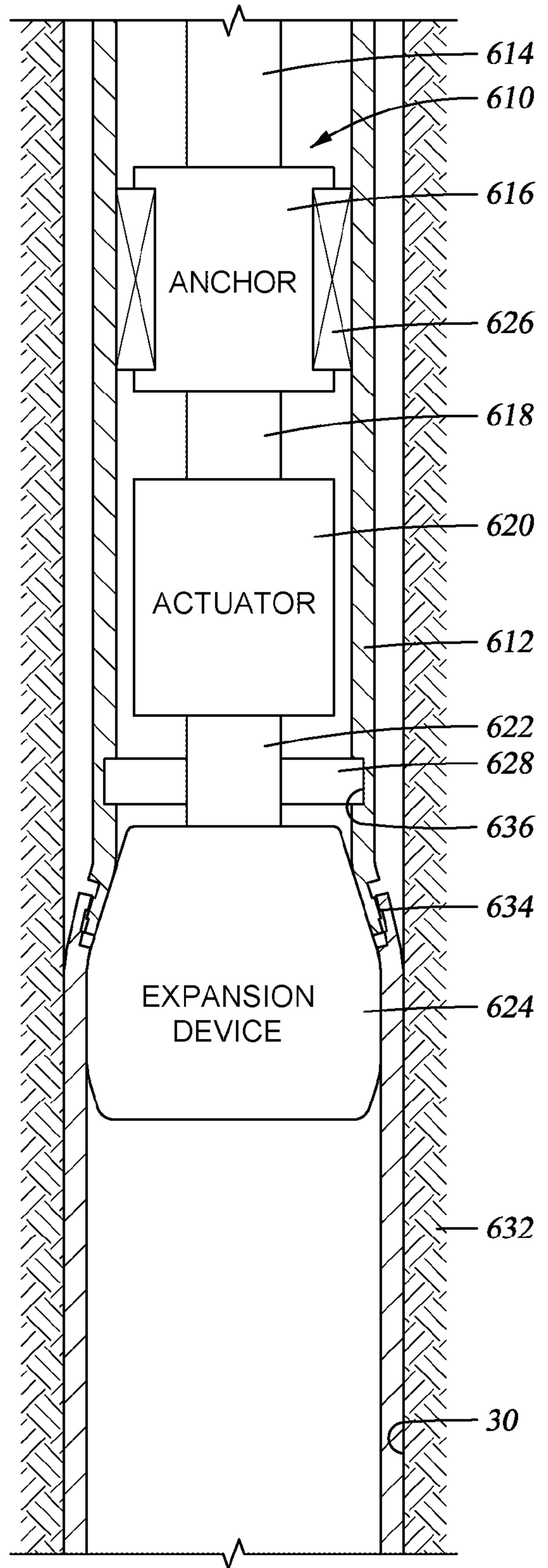

Fig. 25

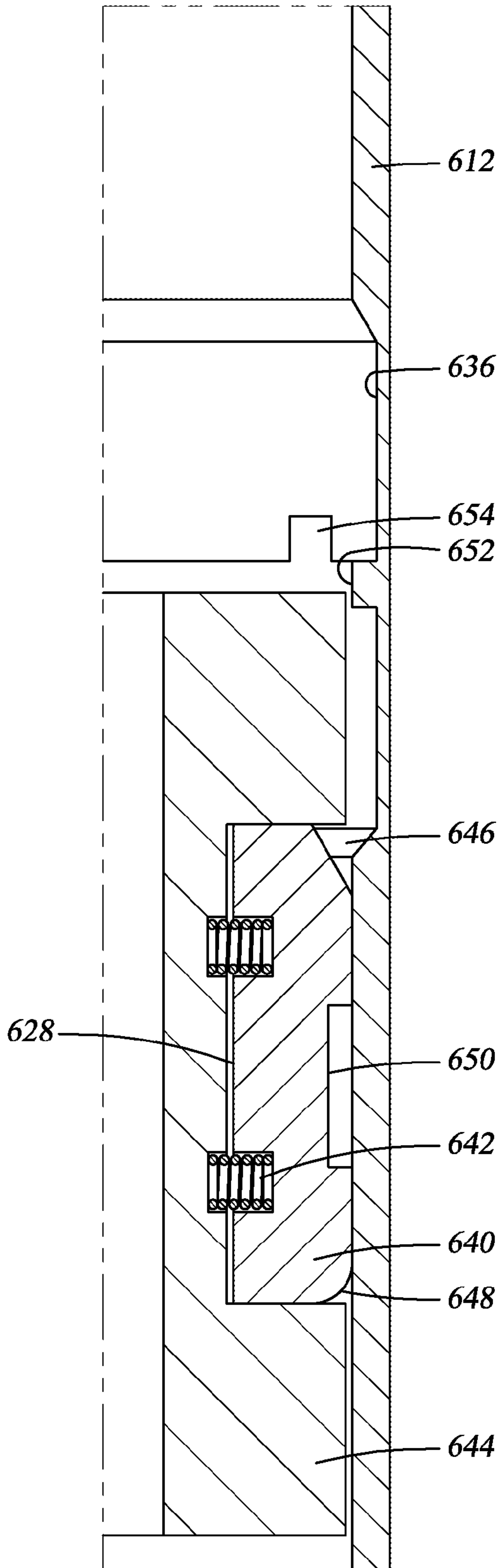

Fig. 26

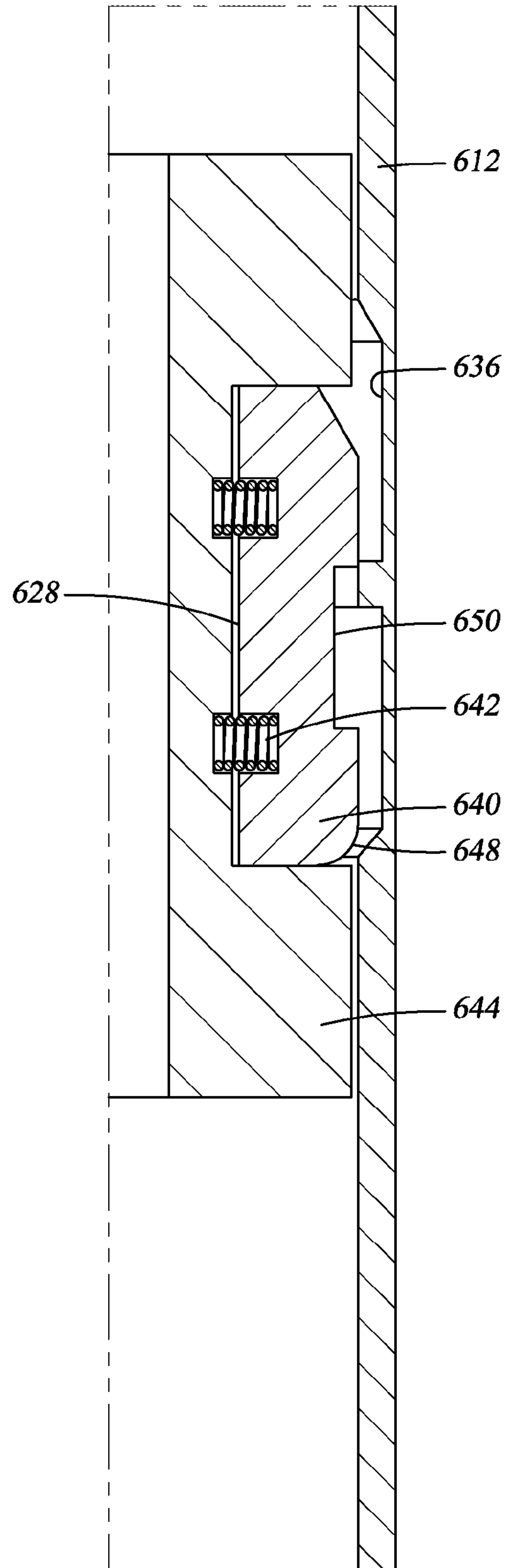

Fig. 27

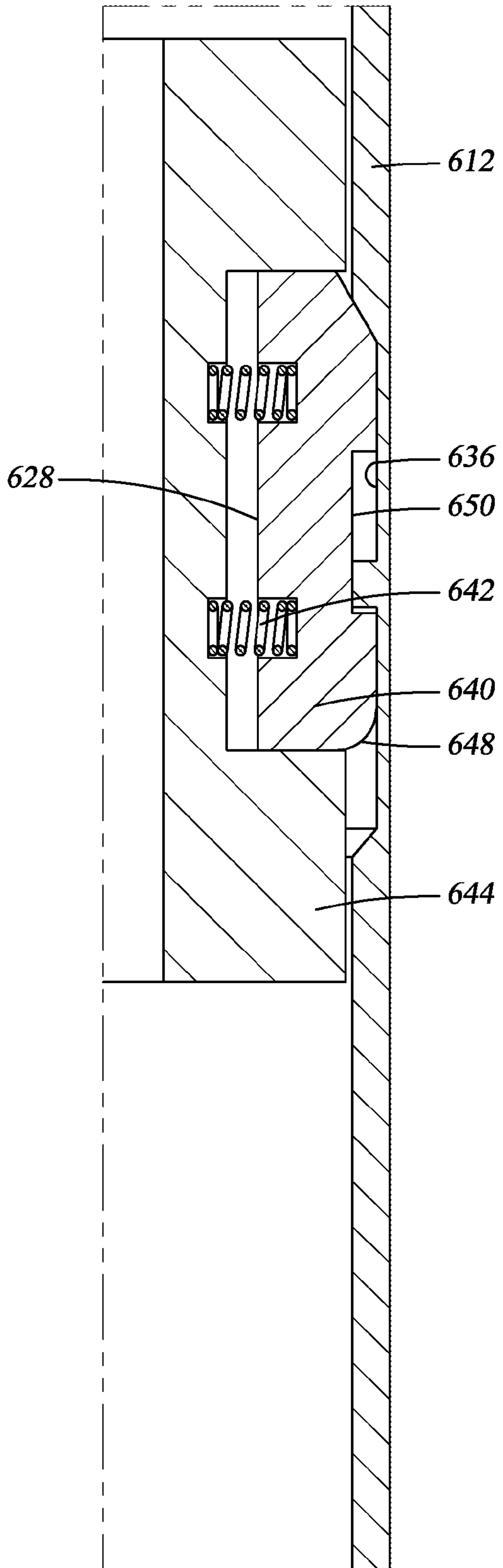

Fig. 28

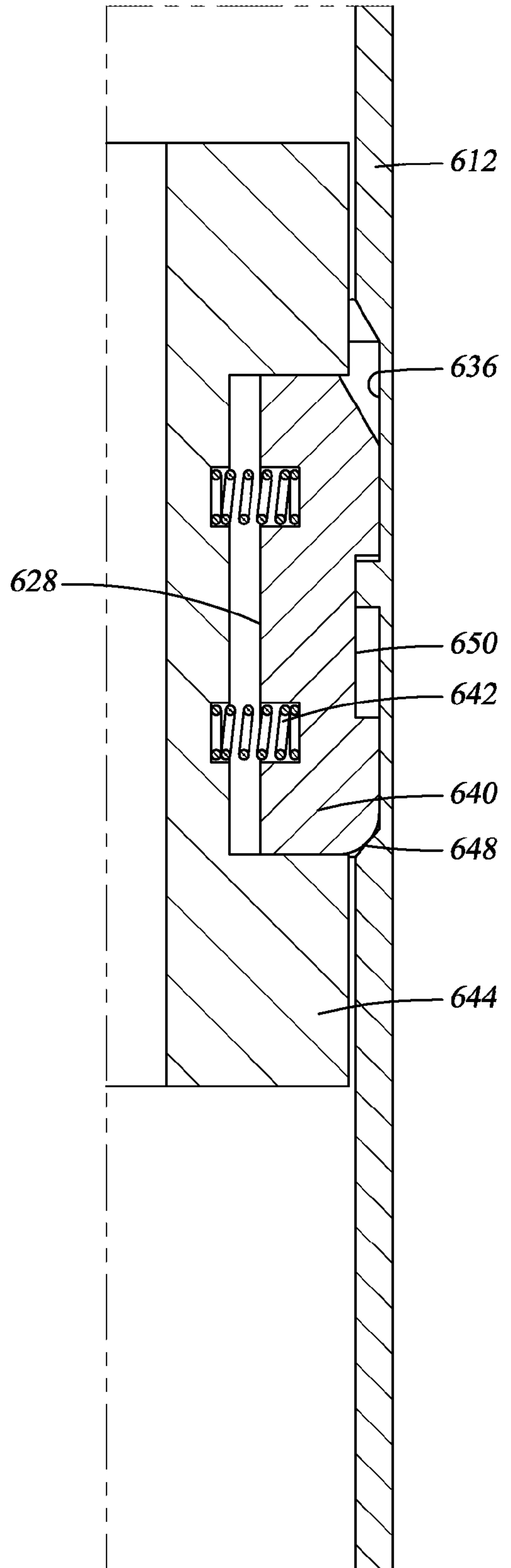

Fig. 29

