



(11) **EP 1 555 127 B1**

(12) **EUROPEAN PATENT SPECIFICATION**

(45) Date of publication and mention of the grant of the patent:
26.08.2009 Bulletin 2009/35

(51) Int Cl.:
B41J 2/165^(2006.01)

(21) Application number: **05100010.7**

(22) Date of filing: **03.01.2005**

(54) **Nozzle cleaning device for an ink jet printer**

Düsenreinigungsverfahren für einen Tintenstrahldrucker

Dispositif de nettoyage des buses pour une imprimante à jet d'encre

(84) Designated Contracting States:
AT BE BG CH CY CZ DE DK EE ES FI FR GB GR HU IE IS IT LI LT LU MC NL PL PT RO SE SI SK TR

(30) Priority: **14.01.2004 EP 04075043**

(43) Date of publication of application:
20.07.2005 Bulletin 2005/29

(73) Proprietor: **Océ-Technologies B.V.**
5914 CC Venlo (NL)

(72) Inventor: **Van Gerven, Antonius J.J.**
5971 AK, GRUBBENVORST (NL)

(74) Representative: **Vanoppen, Ronny R.J. et al**
Océ-Technologies B.V.
Corporate Patents
Postbus 101
5900 MA Venlo (NL)

(56) References cited:
EP-A- 0 578 334 **EP-A- 0 615 846**
WO-A-03/053700 **US-A- 4 558 326**
US-A- 5 659 347 **US-A- 6 095 633**

EP 1 555 127 B1

Note: Within nine months of the publication of the mention of the grant of the European patent in the European Patent Bulletin, any person may give notice to the European Patent Office of opposition to that patent, in accordance with the Implementing Regulations. Notice of opposition shall not be deemed to have been filed until the opposition fee has been paid. (Art. 99(1) European Patent Convention).

Description

[0001] The invention relates to a nozzle cleaning device for an ink jet printer having a plurality of ink reservoirs, the cleaning device comprising a pressure source and a valve mechanism for selectively coupling the pressure source to the ink reservoirs so as to flush the nozzles.

[0002] An ink jet printer typically has a plurality of printheads, e.g. at least one for each colour in case of a multi-colour printer. Each printhead comprises an array of nozzles through which ink droplets can be jetted out onto a recording medium, and an ink reservoir that is in communication with each of the nozzles of the nozzle array through a respective ink channel. In or adjacent to each of the ink channels an actuator, e.g. a piezoelectric actuator is provided which may be energized in order to generate a pressure wave in the liquid ink in the ink channel, so that an ink droplet is expelled from the associated nozzle.

[0003] In some known ink jet printing systems, the ink reservoir is kept under a slight subatmospheric pressure in order to prevent ink from leaking out of the nozzles.

[0004] Since the minute nozzles tend to become clogged with impurities, it is necessary to clean the nozzles from time to time. This is normally achieved by moving the printhead to a cleaning station and then applying a positive pressure to the ink reservoir in order to flush the nozzles with ink from the ink reservoir. The cleaning station comprises a gutter which faces the nozzles of the printhead for collecting the ink that has flown out of the nozzles in the flushing step, and may also comprise a wiper for removing remnants of ink and dust from the nozzle face of the printhead. Another purpose of such a cleaning or flushing procedure is to remove air bubbles that may have entered into the ink channels and could have an adverse effect on the jetting properties of the nozzles.

[0005] In order to limit the required capacity of the pressure source and the dimensions of the cleaning station, it is preferable that the printheads are not cleaned simultaneously but can be cleaned individually by applying pressure only to one ink reservoir at a time when the nozzles connected to this particular ink reservoir are in a position facing the ink collecting system of the cleaning station. This also has the advantage that the amount of waste ink can be reduced by performing the cleaning process only for the printhead or printheads that actually need a cleaning treatment. Then, however, a valve mechanism is required for connecting the pressure source selectively to the ink reservoir of the printhead that is being cleaned. Such a valve mechanism adds to the complexity and costs of the system as a whole, in particular since valves of the direct-driven type ought to be employed in view of the generally small differential pressures involved.

[0006] US-A-6 095 633 discloses a cleaning device of the type described above, in which a separate valve is

provided for each of the ink reservoirs in order to controllably connect the same to a common pressure source.

[0007] US-A-4 870 431 discloses cleaning device for a hot-melt ink jet printer having a rotating printhead with nozzles arranged at the outer periphery for printing onto a sheet of recording paper that has been wrapped around the printhead. Here, the interior of the printhead is subdivided into a plurality of ink reservoirs each having the cross-sectional shape of a sector of a circle. Each reservoir has a supply opening in its top face, so that solid pellets of ink may be dropped into the ink reservoir where the ink is molten. By rotating the printhead, each reservoir opening may be brought into a position where it is aligned with and sealingly connected to an air supply system. When the printhead is locked in this position, pressurized air is supplied into the ink reservoir for flushing the nozzles connected thereto. The rest of the top face of the printhead is covered by a stationary lid for closing off the openings of the ink reservoirs that are not in the cleaning position.

[0008] It is an object of the invention to provide a nozzle cleaning device of the type indicated in the preamble of claim 1, in which the valve mechanism has a simple construction and can be manufactured and assembled at low costs.

[0009] According to the invention, the nozzle cleaning device is **characterized in that** the valve mechanism comprises a valve housing having a wall with a plurality of outlet ports, each of which is connectable to one of the ink reservoirs, and a piston movable in the valve housing and defining therewith a first pressure chamber and having an inlet port connected to the pressure source, the piston being surrounded by a seal which defines, together with said wall of the valve housing, a second pressure chamber adapted to be brought into communication with a selected one of the outlet ports through movement of the piston.

[0010] The ink reservoirs may be constantly connected to the respective outlet ports of the valve housing, and a pressure suitable for flushing the nozzles connected to an individual ink reservoir may selectively be applied by moving the piston into a position in which the seal surrounds the outlet port to which that particular ink reservoir is connected. The seal will thus disconnect that outlet port from the first pressure chamber and will define the second pressure chamber, that is connected to the pressure source through the inlet port of the piston, over an area of the wall of the valve housing which includes only the one outlet port.

[0011] The device according to the invention is thus adaptable to a large variety of ink jet printers and permits a high degree of design choice as regards the arrangement of the printheads and the cleaning station and the way how the printheads are moved into and out of the cleaning station. The valve mechanism may have a compact and simple construction with only a single movable member, i.e. the piston.

[0012] The first pressure chamber may be held at at-

mospheric pressure and will then only have the function to prevent foreign matter from entering through the outlet ports into the ink reservoirs. However, it is a particular advantage of the invention that the first pressure chamber may radially be used for controlling the pressure inside of the ink reservoirs that are not being cleaned. Thus, for example, a single pressure control device is sufficient for keeping the ink reservoirs of all printheads at a slight subatmospheric pressure in order to prevent the leakage of ink from the nozzles, unless the nozzles of the particular printhead are to be cleaned.

[0013] In the cleaning process, the piston may be moved steadily such that the seal passes sequentially over the outlet ports in the wall of the valve housing, so that pressure pulses of predetermined length are successively applied to the individual ink reservoirs.

[0014] Further developments and optional features of the invention are indicated in the dependent claims.

[0015] In a particularly preferred embodiment, the movement of the piston in the valve housing may be coupled with the movement of the printheads relative to the cleaning station, so that the pressure pulses will be applied at appropriate timings, i.e. when the printheads are in the correct cleaning position. The coupling of the movement of the piston with the movement of the printheads may be achieved through mechanical means such as gears, rack-and-pinion devices and the like.

[0016] The movement of the piston in the valve housing may be a linear displacement, a rotation or a combination of both.

[0017] In a particularly preferred embodiment, the piston is moved linearly in a direction in parallel with the movement of a carriage carrying the printheads relative to the cleaning station. Then, the mechanical coupling may be achieved simply by elastically biasing the piston towards one end position and utilizing the relative movement between the carriage and the cleaning station for pushing the piston through the valve housing against the biasing force. To this end, the valve mechanism may be mounted on the carriage carrying the printheads, so that one end of the piston or a piston rod engages a stationary stop when the carriage reaches the cleaning position. As an alternative, the valve mechanism may be mounted stationary relative to the cleaning station, and an abutment on the carriage may be used for actuating the piston.

[0018] A preferred embodiment of the invention will now be described in conjunction with the accompanying drawings, in which:

- Fig. 1 is a schematic view of the cleaning device according to the invention in a state immediately before a cleaning operation starts;
- Fig. 2 is a schematic view similar to figure 1 but for a state in which a single printhead is being cleaned; and
- Fig. 3 is a schematic longitudinal section through a valve mechanism of the device according to the

invention.

[0019] As is shown in figure 1, an ink jet printer to which the invention is applicable comprises a carriage 10 that is movable, for example, linearly along a guide rail 12 so as to scan an sheet of recording paper. The drawing shows only an end portion of the guide rail 12 outside of the area of the recording paper, so that the recording paper is not visible here.

[0020] A number of printheads 14, four in this example, are mounted side by side on the carriage 10 and have nozzle faces 16 arranged in a common plane and facing downward in the drawing so as to oppose the recording paper, when the carriage 10 scans the paper. Each printhead 14 further has an ink reservoir 18, and the ink reservoirs of the different printheads 14 contain liquid inks of different colours.

[0021] The part of the printer that has been shown in figure 1 accommodates a cleaning device for cleaning the nozzles in the nozzle faces 16 of the printheads 14 by flushing the nozzles with liquid ink from the ink containers 18. In order to cause the ink to flow out of the nozzles of the printhead, the cleaning device comprises a pressure source 20 and a distributor valve 22 serving as a valve mechanism for supplying compressed air from the pressure source 20 to the individual ink reservoirs 18, so that the ink will be forced out through the nozzles. The ink that has been jetted out of the nozzles in this way is captured and collected in a gutter 24 which is arranged to face the nozzle face 16 of the printhead that is currently being cleaned. Optionally, the gutter 24 may be combined with a wiper assembly for wiping off remnants of ink from the nozzle faces 16 while the carriage 10 moves past the gutter.

[0022] The distributor valve 22 comprises an outer tube serving as a valve housing 26 and an inner tube serving as a piston 28 that is slidably accommodated in the valve housing. Both, the valve housing 26 and the piston 28 are connected to the pressure source 20 through flexible tubes 30, 32 and 34, respectively, which have a sufficient length and flexibility to follow the path of travel of the carriage 10 along the guide rail 12. Through the tubes 30, 32 that are connected to the valve housing 26, the pressure source 22 supplies a slight subatmospheric pressure in the order of magnitude of about -1000 Pa, for example. This pressure is normally maintained in the ink reservoirs 18 of the printheads 14 when the printheads are operating or idle, in order to prevent the ink from leaking out of the nozzles. The tube 34 is connected to one end of the piston 28 and supplies a pulse of positive air pressure, e.g. in the order of 10 kPa, individually and successively to the ink reservoirs 18 of the various printheads 14 at appropriate timings so as to flush the nozzles of each printhead when this printhead moves past the gutter 24.

[0023] The supply of air to the ink reservoirs 18 of the individual printheads 14 is controlled by the movement of the piston 28 relative to the valve housing 26, and this

movement is controlled by the movement of the carriage 10 relative to the guide rail 12.

[0024] As is shown in figure 1, the piston 28 projects beyond the ends of the valve housing 26 on both sides, and stops 36, 38 are provided on both ends of the piston. In the condition shown in figure 1, the carriage 10 is just approaching the cleaning device in the direction of the arrow, and the piston 28 is held in a rest position in which the stop 36 engages the left end of the valve housing 26. The piston is held in this rest position by a compression spring 40 that biases the opposite end of the piston 28 away from the valve housing 26. The stop 38 at this end of the piston is just about to reach an abutment 42 that is held stationary relative to the guide rail 12. When the carriage 10 moves further to the left in figure 1, the stop 38 engages the abutment 42, and the piston 28 is pushed through the valve housing 26. This is illustrated in figure 2, where the carriage 10 has been moved further to a position in which the nozzle face 16 of the third printhead is facing the gutter 24.

[0025] The internal construction of the distributor valve 22 is shown in figure 3. Here, the tubular valve housing 26 is shown to have seal rings 44 at both ends, by which the piston 28 is slidingly guided in the valve housing, so that an annular first pressure chamber 46 is formed between the piston 28 and the internal wall of the valve housing 26 and is closed-off at both ends by the seal rings 44. This first pressure chamber 46 has four outlet ports 48 that are axially aligned in the circumferential wall of the valve housing 26 and are shaped as connectors to be respectively connected to one of the ink reservoirs 18 of the printheads 14. Further, the valve housing 26 has two connectors 50 which are arranged near the opposite ends of the valve housing and serve to connect the low-pressure tubes 30 and 32 to the first pressure chamber 46.

The tubular piston 28 is closed by the stop 38 at one end, whereas the other end forms a connector 52 for the high-pressure tube 34. In the axial center of the piston 28, two seal rings 54 are fixed on the outer surface of the piston. Together, these seal rings 54 form a seal which separates an annular second pressure chamber 56 from the first pressure chamber 46. The seal rings 54 also divide the first pressure chamber 46 into two separate compartments, which is the reason for providing two connectors 50, one for each compartment.

[0026] An inlet port 60 of the second pressure chamber 56 is formed in the peripheral wall of the piston 28 in a section between the two seal rings 54. In the condition shown in figure 3, the inlet port 60 and the second pressure chamber 56 are aligned with the third outlet port 48, so that the high pressure supplied via the tube 34 will be forwarded through the interior of the piston 28, the inlet port 60, the second pressure chamber 56 and the outlet port 48 into the ink reservoir 18 of the third printhead. This corresponds to the condition shown in figure 2, where the third printhead faces the gutter 24.

[0027] In the condition shown in figure 1, when the pis-

ton 28 is in its rest position, the inlet port 60 would be in a position near the right connector 50, and in this position the second pressure chamber 56 is connected to none of the outlet ports 48 nor to the connector 50. In figure 3, this position of the inlet port 60 is indicated by an arrow A.

[0028] When the piston 28 is in the rest position, and the carriage 10 approaches the abutment 42, the second pressure chamber 56 moves past the outlet ports 48, so that the high pressure is applied successively to the ink reservoirs of the printheads 14 in synchronism with the movement of the printheads past the gutter 24. A second series of cleaning steps will be performed in reserve order when the carriage moves away from the abutment 42 in the reverse stroke. Thus, a two-step cleaning process will automatically be performed separately for each of the printheads 14 whenever the carriage 10 is moved to the end portion of the guide rail 12 where the cleaning device is located.

[0029] In the example shown in figure 3, the piston 28 has additional seal rings 62 at both ends. These seal rings 62 will enter into the valve housing 26 and engage the seal rings 44 of the latter when the piston reaches one of its two end positions. It should be noted that the seal rings 54 delimiting the second pressure chamber 56 are movable with the piston 28, whereas the seal rings 44 are stationary relative to the valve housing 26. In the process of assembly, the seal rings 44 which are arranged close to the ends of the valve housing 26 may be inserted after the piston 28 carrying the seal rings 54 has been inserted into the valve housing but before the stops 36, 38 are mounted on the piston.

[0030] It will occur to a person skilled in the art that the embodiment described above may be modified in various ways. For example, the distributor valve 22 may be arranged stationary relative to the guide rail 12 and the pressure source 20, if the printheads 14 are connected to the valve housing 26 through respective flexible tubes. The abutment 42 would then be replaced by an abutment arranged appropriately on the carriage 10. As another alternative, the piston 28 of the distributor valve may be driven by any suitable drive mechanism such as a rack-and-pinion assembly or the like which itself is driven synchronously with the movement of the carriage.

Claims

1. A nozzle cleaning device for an ink jet printer having a plurality of ink reservoirs (18), the cleaning device comprising a pressure source (20) and a valve mechanism (22) for selectively coupling the pressure source to the ink reservoirs so as to flush the nozzles, **characterized in that** the valve mechanism comprises a valve housing (26) having a wall with a plurality of outlet ports (48), each of which is connectable to one of the ink reservoirs (18), and a piston (28) movable in the valve housing and defining therewith a first pressure chamber (46) and having an inlet

- port (60) connected to the pressure source (20), the piston being surrounded by a seal (54) which defines, together with said wall of the valve housing (26), a second pressure chamber (56) adapted to be brought into communication with a selected one of the outlet ports (48) through movement of the piston (28).
2. The nozzle cleaning device of claim 1, comprising means (30, 32, 50) for keeping the first pressure chamber (46) under subatmospheric pressure.
 3. The nozzle cleaning device of claim 1 or 2, for a printer in which each ink reservoir (18) is mounted in or on a movable printhead (14), comprising means (38, 42) for coupling the movement of the piston (28) with the movement of the printheads (14).
 4. The nozzle cleaning device of claim 3, comprising a gutter (24) arranged to collect ink that is jetted out from the nozzles in the cleaning process, wherein the coupling means (38, 42) are arranged to synchronize the movement of the piston (28) relative to the valve housing (26) with the movement of the printheads (14) relative to the gutter (24) such that the ink reservoir (18) of a printhead (14) is connected to the pressure source (20) only when this printhead is facing the gutter (24).
 5. The nozzle cleaning device of claim 3 or 4, wherein the valve housing (26) has a tubular shape and the piston (28) is movable axially through the valve housing.
 6. The nozzle cleaning device of claim 5, wherein the piston (28) is a hollow tube connected to the pressure source (20), the inlet port (60) is defined in the peripheral wall of this hollow tube, and the seal (54) is formed by two seal rings surrounding the piston on either side of the inlet port (60).
 7. The nozzle cleaning device of claims 2 and 6, wherein the valve housing (26) has two connectors (50) that are both connected to a source of subatmospheric pressure and are arranged near opposite ends of the valve housing and axially offset from the outlet ports (48).
 8. The nozzle cleaning device of claim 6 or 7, wherein the valve housing (26) extends in parallel with the direction of relative movement of the printheads (14) and the gutter (24), and the piston (28) projects out of the valve housing (26) at both ends thereof, is elastically biased into an end position relative to the valve housing and is adapted to cooperate with an abutment (42) so as to be pushed through the valve housing in accordance with the relative movement of the printheads (14) and the gutter (24).

9. An ink jet printer having the nozzle cleaning device of claim 8, wherein the printheads (14) and the valve mechanism (22) are mounted on a common carriage (10) that is movable relative to the gutter (24).
10. The ink jet printer of claim 9, wherein the pressure source (20) is stationary relative to the gutter (24) and is connected to the valve mechanism (22) through flexible tubes (30, 32, 34).

Patentansprüche

1. Düsenreinigungsvorrichtung für einen Tintenstrahldrucker, der mehrere Tintenbehälter (18) aufweist, wobei die Reinigungsvorrichtung eine Druckquelle (20) und einen Ventilmechanismus (22) zum selektiven Ankuppeln der Druckquelle an die Tintenbehälter aufweist, damit die Düsen gespült werden, **dadurch gekennzeichnet, daß** der Ventilmechanismus ein Ventilgehäuse (26), das eine Wand mit einer Vielzahl von Auslaßöffnungen (48) hat, von denen jede mit einem der Tintenbehälter (18) verbindbar ist, und einen Kolben (28), der in dem Ventilgehäuse bewegbar ist und mit diesem eine erste Druckkammer (46) bildet, und einen Einlaß (60) aufweist, der mit der Druckquelle (20) verbunden ist, wobei der Kolben von einer Dichtung (54) umgeben ist, die zusammen mit der genannten Wand des Ventilgehäuses (26) eine zweite Druckkammer (56) definiert, die dazu eingerichtet ist, durch Bewegung des Kolbens (28) mit einer ausgewählten Öffnung unter den Auslaßöffnungen (48) in Verbindung gebracht zu werden.
2. Düsenreinigungsvorrichtung nach Anspruch 1, mit Mitteln (30, 32, 50), die die erste Druckkammer (46) unter Unterdruck halten.
3. Düsenreinigungsvorrichtung nach Anspruch 1 oder 2, für einen Drucker, bei dem jeder Tintenbehälter (18) in oder auf einem beweglichen Druckkopf (14) montiert ist, mit Mitteln (38, 42) zum Koppeln der Bewegung des Kolbens (28) mit der Bewegung der Druckköpfe (14).
4. Düsenreinigungsvorrichtung nach Anspruch 3, mit eine Ablauf (24), der dazu ausgebildet ist, Tinte aufzufangen, die in dem Reinigungsprozeß aus den Düsen ausgestoßen wurde, wobei die Kupplungsmittel (38, 42) dazu ausgebildet sind, die Bewegung des Kolbens (28) relativ zu dem Ventilgehäuse (26) mit der Bewegung der Druckköpfe (14) relativ zu dem Ablauf (24) so zu synchronisieren, daß der Tintenbehälter (18) eines Druckkopfes (14) nur dann mit der Druckquelle (20) verbunden ist, wenn dieser Druckkopf dem Ablauf (24) gegenüberliegt.

5. Düsenreinigungsvorrichtung nach Anspruch 3 oder 4, bei der das Ventilgehäuse (26) eine rohrförmige Gestalt hat und der Kolben (28) axial durch das Ventilgehäuse hindurch bewegbar ist.
6. Düsenreinigungsvorrichtung nach Anspruch 5, bei der der Kolben (28) ein hohles Rohr ist, das mit der Druckquelle (20) verbunden ist, der Einlaß (60) in der Umfangswand dieses hohlen Rohres gebildet ist und die Dichtung (54) durch zwei Dichtringe gebildet wird, die den Kolben auf jeder Seite des Einlasses (60) umgeben.
7. Düsenreinigungsvorrichtung nach den Ansprüchen 2 und 6, bei der das Ventilgehäuse (26) zwei Verbinder (50) aufweist, die beide mit einer Unterdruckquelle verbunden und in der Nähe entgegengesetzter Enden des Ventilgehäuses und axial von den Auslaßöffnungen (48) versetzt angeordnet sind.
8. Düsenreinigungsvorrichtung nach Anspruch 6 oder 7, bei der das Ventilgehäuse (26) sich parallel zu der Richtung der Relativbewegung der Druckköpfe (14) und des Ablaufes (24) erstreckt und der Kolben (28) an seinen beiden Enden aus dem Ventilgehäuse (26) herausragt, elastisch in eine Endlage relativ zu dem Ventilgehäuse vorgespannt ist und dazu eingerichtet ist, mit einem Anschlag (42) so zusammenzuwirken, daß er in Übereinstimmung mit der Relativbewegung der Druckköpfe (14) und des Ablaufes (24) durch das Ventilgehäuse geschoben wird.
9. Tintenstrahldrucker mit der Düsenreinigungsvorrichtung nach Anspruch 8, wobei die Druckköpfe (14) und der Ventilmechanismus (22) an einem gemeinsamen Wagen (10) montiert sind, der relativ zu dem Ablauf (24) beweglich ist.
10. Tintenstrahldrucker nach Anspruch 9, bei dem die Druckquelle (20) relativ zu dem Ablauf (24) stationär ist und über flexible Schläuche (30, 32, 34) mit dem Ventilmechanismus (22) verbunden ist.

Revendications

1. Dispositif de nettoyage d'injecteur pour une imprimante à jet d'encre comportant une pluralité de réservoirs d'encre (18), le dispositif de nettoyage comprenant une source de pression (20) et un mécanisme formant vanne (22) destiné à coupler de manière sélective la source de pression aux réservoirs d'encre afin de rincer les injecteurs, **caractérisé en ce que** le mécanisme formant vanne comprend un boîtier de vanne (26) présentant une paroi avec une pluralité d'orifices de sortie (48), chacun d'eux pouvant être raccordé à l'un des réservoirs d'encre (18), et un piston (28) pouvant être déplacé dans le boîtier

de vanne et définissant avec celui-ci une première chambre de pression (46) et comportant un orifice d'entrée (60) raccordé à la source de pression (20), le piston étant entouré par un joint (54) qui définit, conjointement avec ladite paroi du boîtier de vanne (26), une seconde chambre de pression (56) adaptée de manière à être mise en communication avec l'un des orifices de sortie sélectionné (48) par l'intermédiaire du déplacement du piston (28).

2. Dispositif de nettoyage d'injecteur selon la revendication 1, comprenant des moyens (30, 32, 50) destinés à maintenir la première chambre de pression (46) sous une pression inférieure à la pression atmosphérique.
3. Dispositif de nettoyage d'injecteur selon la revendication 1 ou 2, pour une imprimante dans laquelle chaque réservoir d'encre (18) est monté dans ou sur une tête d'impression pouvant se déplacer (14), comprenant des moyens (38, 42) destinés à coupler le mouvement du piston (28) avec le mouvement des têtes d'impression (14).
4. Dispositif de nettoyage d'injecteur selon la revendication 3, comprenant une gouttière (24) agencée de manière à collecter l'encre qui est injectée par les injecteurs au cours de l'opération de nettoyage, dans lequel les moyens de couplage (38, 42) sont agencés afin de synchroniser le mouvement du piston (28) par rapport au boîtier de vanne (26) avec le mouvement des têtes d'impression (14) par rapport à la gouttière (24) de telle sorte que le réservoir d'encre (18) d'une tête d'impression (14) soit couplé à la source de pression (20) uniquement lorsque cette tête d'impression est face à la gouttière (24).
5. Dispositif de nettoyage d'injecteur selon la revendication 3 ou 4, dans lequel le boîtier de vanne (26) présente une forme tubulaire et le piston (28) peut se déplacer axialement à travers le boîtier de vanne.
6. Dispositif de nettoyage d'injecteur selon la revendication 5, dans lequel le piston (28) est un tube creux raccordé à la source de pression (20), l'orifice d'entrée (60) est défini dans la paroi périphérique de ce tube creux, et le joint (54) est formé par deux bagues d'étanchéité entourant le piston de chaque côté de l'orifice d'entrée (60).
7. Dispositif de nettoyage d'injecteur selon les revendications 2 et 6, dans lequel le boîtier de vanne (26) présente deux raccords (50) qui sont tous deux raccordés à une source de dépression et sont agencés à proximité d'extrémités opposées du boîtier de vanne et décalés axialement par rapport aux orifices de sortie (48).

8. Dispositif de nettoyage d'injecteur selon la revendication 6 ou 7, dans lequel le boîtier de vanne (26) s'étend parallèlement à la direction du déplacement relatif des têtes d'impression (14) et de la gouttière (24), et le piston (28) s'étend hors du boîtier de vanne (26) à ses deux extrémités, est appliqué de manière élastique vers une position extrême par rapport au boîtier de vanne et est adapté afin de coopérer avec une butée (42) de manière à être poussé à travers le boîtier de vanne en fonction du mouvement relatif des têtes d'impression (14) et de la gouttière (24).
9. Imprimante à jet d'encre comportant le dispositif de nettoyage d'injecteur selon la revendication 8, dans laquelle les têtes d'impression (14) et le mécanisme formant vanne (22) sont montés sur un chariot commun (10) qui est peut se déplacer par rapport à la gouttière (24).
10. Imprimante à jet d'encre selon la revendication 9, dans laquelle la source de pression (20) est fixe par rapport à la gouttière (24) et est couplée au mécanisme formant vanne (22) par l'intermédiaire de tubes flexibles (30, 32, 34).

5

10

15

20

25

30

35

40

45

50

55

Fig. 1

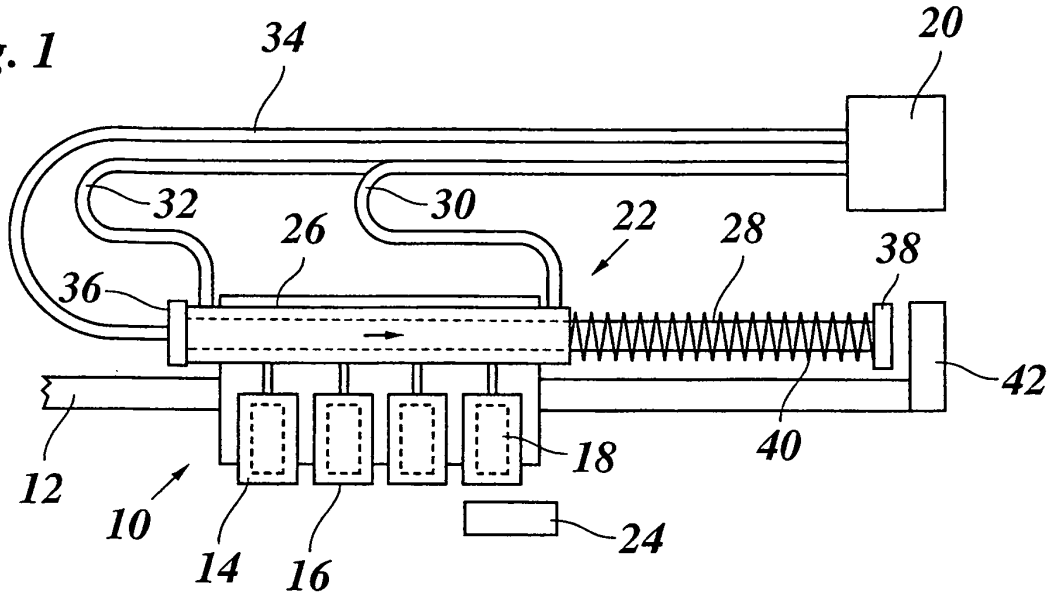

Fig. 2

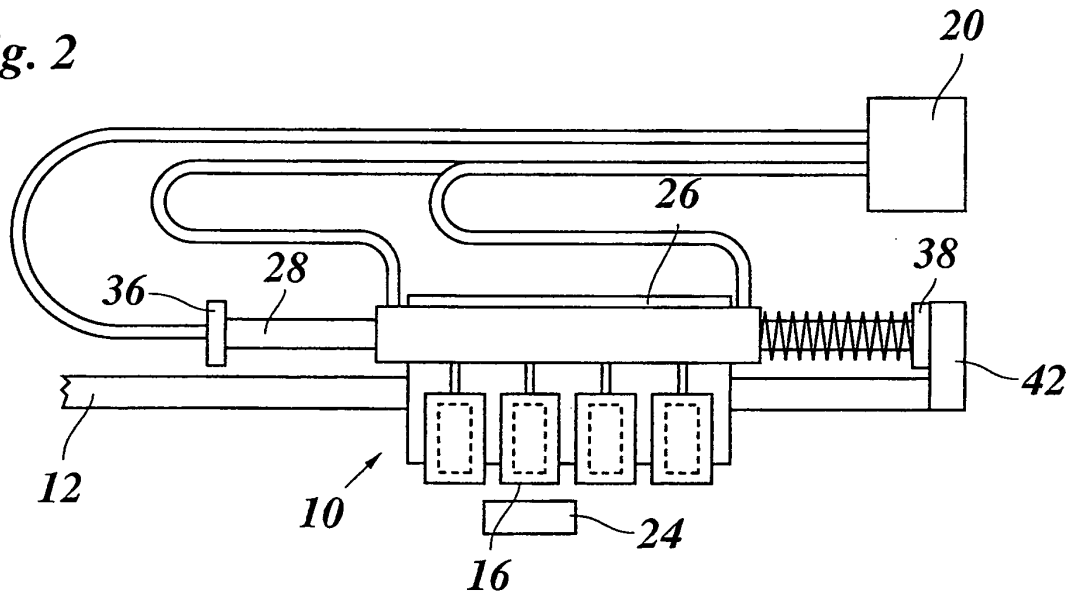
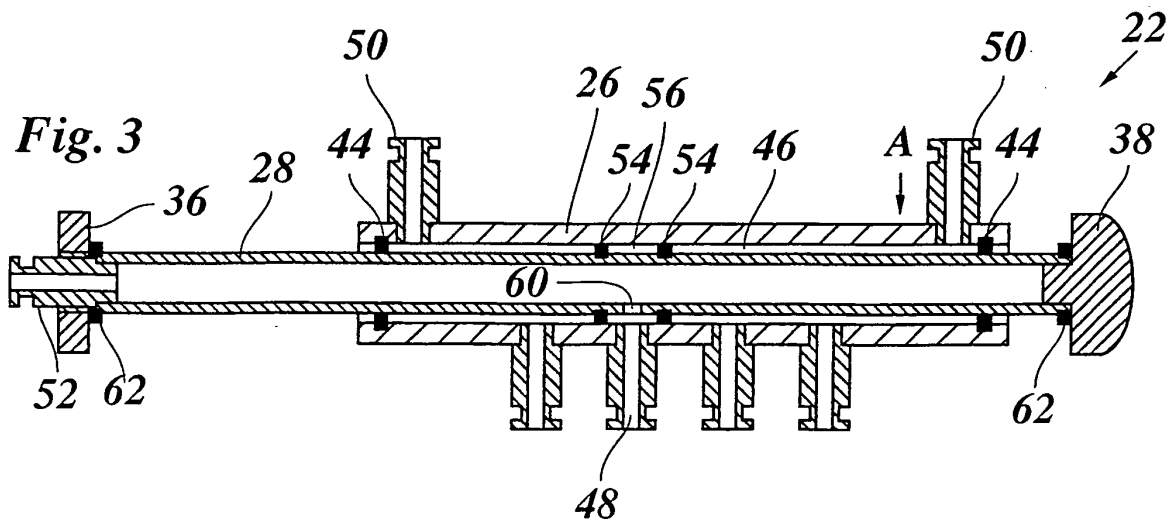

Fig. 3



REFERENCES CITED IN THE DESCRIPTION

This list of references cited by the applicant is for the reader's convenience only. It does not form part of the European patent document. Even though great care has been taken in compiling the references, errors or omissions cannot be excluded and the EPO disclaims all liability in this regard.

Patent documents cited in the description

- US 6095633 A [0006]
- US 4870431 A [0007]