



(12) **EUROPEAN PATENT APPLICATION**

(43) Date of publication:
02.04.2003 Bulletin 2003/14

(51) Int Cl.7: **B43M 3/04, B65H 39/10**

(21) Application number: **02021821.0**

(22) Date of filing: **27.09.2002**

(84) Designated Contracting States:
**AT BE BG CH CY CZ DE DK EE ES FI FR GB GR
 IE IT LI LU MC NL PT SE SK TR**
 Designated Extension States:
AL LT LV MK RO SI

(72) Inventor: **Chapman, Carl R.
 Monroe, Connecticut 06468 (US)**

(74) Representative: **HOFFMANN - EITLÉ
 Patent- und Rechtsanwälte
 Arabellastrasse 4
 81925 München (DE)**

(30) Priority: **28.09.2001 GB 0123405**

(71) Applicant: **Pitney Bowes Limited
 Harlow, Essex CM19 5BD (GB)**

(54) **Apparatus and method for collating sheets**

(57) Sheet collation apparatus is disclosed in which an initial sheet (A_1) from a sheet feeder (4) is advanced to a collation station (10), reversed into an accumulation station (8) and then returned to the collation station

where it is collated with the next sheet (A_2) from the sheet feeder. This process may be repeated any number of times to form a collation of sheets of any required number.

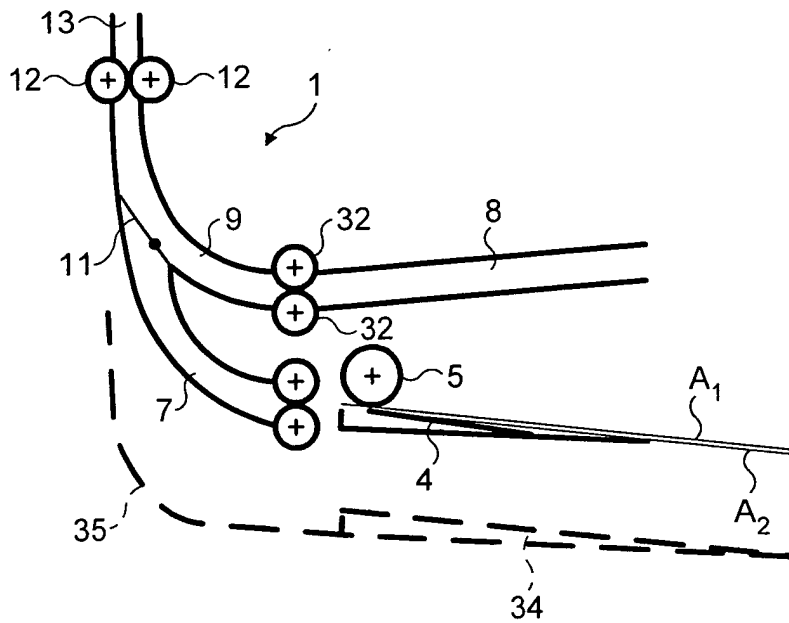

FIG. 3a

Description

[0001] This invention relates to apparatus for collating sheets, such as may be incorporated in an inserter for inserting sheets into envelopes.

[0002] Inserter systems are used by organizations such as banks, insurance companies and utility companies for producing a large volume of specific mailings where the contents of each mail item are directed to a particular addressee. Additionally, other organizations, such as direct mailers, use inserts for producing a large volume of generic mailings where the contents of each mail item are substantially identical for each addressee. Examples of such high volume inserter systems are the 8,9 and 14 series inserter systems available from Pitney Bowes, Inc., Stamford, Connecticut.

[0003] However, inserter systems are not limited to such high volume applications as they also have considerable utility in lower volume applications, such as SOHO (small office/home office) applications. An example of such a SOHO inserter system is the tabletop 3 Series inserter system available from Pitney Bowes Limited, Harlow, England. This inserter system has been designed for implementation on a table top surface while providing many automated features and requiring little maintenance. In other words, it has been designed to be operated by an ordinary office worker with little or no training in operating inserter systems. Therefore, regarding the operation of such inserters, it is critical that they provide many automated and self adjusting features while having a high degree of reliability.

[0004] Inserters are well known having sheet feeding stations for feeding for example individually typewritten or printed sheets, an optional insert feeder for feeding standard inserts (e.g. advertising material, printed information that is uniform for all addressees etc.), a folding station for folding sheets fed from the sheet feeders and receiving one or more inserts into a fold produced by the folding station, an envelope feeding station, an insertion station to which the envelope is fed, with its flap in an open position, an envelope opening device at the insertion station for separating the front and rear panels of the envelope, a feed path for feeding the folded sheets, and any inserts, into the waiting open mouthed envelope at the insertion station, an optional moistener for receiving the filled envelopes from the insertion station and for moistening the (gummed) envelope flap, an envelope sealing device for sealing the envelope and an outlet through which the filled and sealed envelope is delivered for the application of postage and for subsequent mailing.

[0005] A particular example of such an inserter designed for lower volume applications is disclosed in the present Applicants' EP-A-0 700 794 and EP-A-0 943 459 (European patent application 99 104 095.7). The inserter is a tabletop inserter and generally consists of an upper housing mounted atop a lower housing. Upper housing generally includes first and second sheet feed-

ers and, preferably an insert feeder. Individual sheets are preferably conveyed from each sheet feeder and into respectively first and second feed paths. The first and second sheet paths merge with one another at a collation station having first and second collating rollers. The collating station is operative to align the leading edges of first and second sheets being respectively conveyed from the first and second sheet feeders, via the first and second sheet paths, within the nip formed between the collating rollers. Once aligned, the collating rollers are actuated to simultaneously feed the aligned sheets in a supply path downstream of the collating station. These aligned sheets are also known as a "collation". This sheet collation as prepared by the sheet collation apparatus described above is then conveyed downstream in the supply path to the folding station. After this, the folded collation is inserted into an open envelope and the envelope flap moistened and sealed, these steps being performed automatically by the inserter as described in the opening passage of this specification.

[0006] When using the inserter described, each sheet feeder is loaded with sheets of a different kind. Therefore, when preparing a collation of two sheets which can be regarded as sheet 1 followed by sheet 2, one tray is loaded exclusively with sheets 1 while the other tray is loaded exclusively with sheets 2. Since sheets 1 and 2 can be fed simultaneously to the nip of the collating rollers at the collation station, each collation can be assembled relatively rapidly. However, the operator has to load each tray manually with a batch of identical sheets of the appropriate kind, which is different for the different trays. When using an associated printer, typically a laser jet printer in an office environment for example, the operator has to instruct the printer to print a first batch of sheets 1, and then re-instruct the printer to print a second batch of sheets 2, which two batches are then loaded manually into the two sheet feeders. These manual operations are time-consuming. Still further, forming a collation of three or more sheets would require a corresponding number of different sheet feeders.

[0007] It is an objective of this invention to provide a simple, inexpensive and reliable inserter, particularly though not exclusively suited to the low volume user, which is not subject to the above disadvantages.

[0008] According to the invention from one aspect, there is provided apparatus for collating sheets, comprising:

- (i) a collation station;
- (ii) feeding means for successively feeding a plurality of sheets one at a time along a first path to the collation station;
- (iii) an accumulation station;
- (iv) transferring means for transferring the sheet(s) at the collation station, after each feeding of a sheet to that station, along a second path to the accumulation station;
- (v) sheet returning means associated with the ac-

cumulation station for returning the sheet (s) at the accumulation station to the collation station;

(vi) means at the collation station for collating those sheet(s) and the next of the successively fed sheets, such collation being repeated, in operation of the sheet collating apparatus, until a sheet collation of a predetermined number of sheets is formed at the collation station, and

(vii) first driving means for driving said collation of a predetermined number of sheets from the collation station along a third path.

[0009] Since the sheet(s) received by the accumulation station for return to the collation station originated from the feeding means, which also supplies the next sheet to the collation station, it is necessary for the operator to manually prepare only one stack of sheets for the sheet feeding means (when taking the form of a sheet feeding tray or the like), the stack consisting of successive alternate sheet numbers, i.e. sheet 1, sheet 2, sheet 1, sheet 2 etc. Furthermore, a printer used for printing the sheets only needs to be set once for printing such sheets and can be left at the same setting for printing all subsequent batches of sheets for the sheet feeder. By contrast, with the conventional inserter the operator has to separately instruct the printing of two batches of differently number sheets, and to reinstruct the printer twice for the printing of each subsequent batch.

[0010] To provide continuous operation, it would be possible for the sheet feeding means to comprise an automatic sheet feeder connected to supply sheets printed by a printer, directly to the collation station. Then, there would be no need for operator intervention at all.

[0011] Yet another advantage is that the collation apparatus may be used for forming a collation of two, three or any other higher predetermined number of sheets. The known collator according to our above-mentioned European patent application EP-A-0 700 794 and EP-A-0 943 459, however, can only form a collation of two sheets since it has only two sheet feeders. Whilst in principle further sheet feeders could be incorporated in the collator where a collation of three or more sheets is required, this would undesirably add to the constructional complexity, geometrical dimensions and cost. Although the time required for forming a collation with the improved collation apparatus disclosed herein increases according to the number of sheets forming the collation, this is of much lesser importance to the low volume user than the lower cost, smaller size and greater constructional simplicity (and therefore enhanced reliability) of the collation apparatus disclosed in this specification.

[0012] In a preferred arrangement, the collation station is provided with a pair of collation rollers defining a nip and power means operable for rotatably driving the rollers, the nip of the rollers, when the latter are not driven, serving for effecting the collation of sheets at the collation station when driven into the nip and the rollers being drivable in association with second driving means of

the accumulation station for selectively effecting the transfer of sheet(s) to the accumulation station and the driving of said collation from the collation station along the exit path, the second driving means being reversible for effecting the return of the sheet(s) at the accumulation station to the collation station. Such multi-tasking of the collation rollers contributes to constructional simplicity.

[0013] Desirably, the first and second paths merge ahead of the nip of the collation rollers, and the collation station includes a diverter movable between a first position for permitting the feeding of each sheet along the first path to the collation station and a second position for diverting the sheet(s) along the second path during the transfer thereof from the collation station to the accumulation station. The diverter functions as a simple and effective means for effecting the required routing of the sheet(s) from the collation station to the accumulation station.

[0014] According to the invention from another aspect, there is provided apparatus for collating sheets, comprising:

(i) a collation station including a pair of rollers defining a nip;

(ii) power means operable for selectively applying drive to the rollers;

(iii) feeding means for feeding a plurality of sheets one at a time along a first path to the collation station and into the nip of the rollers when they are non-driven;

(iv) an accumulation station, there being a second path interposed between the accumulation station and the collation station; and

(v) a diverter positioned between the first path and the collation station and movable between a first position permitting the feeding of each sheet along the first path to the collation station and a second position;

wherein

(vi) the power means is arranged to apply drive to the rollers to initially drive the sheet(s) located in the nip of the roller along a third path from the collation station in one direction until the trailing edge of the sheet(s) moves clear of the diverter, whereafter the direction of drive is reversed, the diverter which is then in its second position diverting the sheet(s) along said second path to the accumulation station;

(vii) the accumulation station has driving means operable for selectively applying drive to the sheet(s) diverted to the accumulation station and for thereafter returning the sheet(s) along the second path to the collation station at which the nip of the rollers, which are then non driven, collates those sheets and the next of the successively fed sheets; and

(viii) such collation is repeated, in operation of the sheet collating apparatus, until a sheet collation of a predetermined number of sheets is formed at the

collation station, the power means then being arranged to apply drive to the rollers to drive the collation along the third path in said one direction.

[0015] Such apparatus affords all the advantages offered by the collation apparatus according to the first aspect, while also displaying constructional simplicity through the multi-tracking operation of the rollers and the use of the diverter, which can take the form of a pivotably mounted guide.

[0016] A particularly compact arrangement results from a sheet collating apparatus in which the feeding means comprises a generally horizontally arranged tray for a stack of sheets, and a feeder for feeding one sheet at a time from the tray to the collation station, and wherein said tray is arranged in a lower region within a main housing of the apparatus, the accumulation station being located above the tray. This arrangement for the tray and accumulation station also lends itself readily to be designed so as to be accessible from the front of the apparatus, which is convenient for the operator, while not occupying space that would normally be required for the operator interface/operating panel, (i.e. at a raised position on the front and/or top of the main housing).

[0017] Preferably, the accumulation station is arranged also to serve as a daily mail feeder, so that a selected insert sheet or groups of sheets may be manually inserted into the accumulation feeder, after the collation of the predetermined number of sheets has been formed. The accumulation station is then arranged to feed the inserted daily mail to the collation station, after which the collation, together with the collated daily mail, is driven from the collation station along the third path.

[0018] In order to provide increased versatility and/or operating options, the apparatus for collating sheets may further comprise an auxiliary sheet feeding path for connection to a sheet printing apparatus or a supplementary sheet feeding tray for use in delivering printed sheets supplied one at a time from the printing apparatus or supplementary sheet feeding tray, to the collation station.

[0019] It is preferable for the driving means of the accumulation station to comprise a pair of rollers defining a nip. In this way, it is possible to handle daily mail in the form of a stapled collation of sheets.

[0020] Desirably, the first and second paths are so arranged as to reorientate each sheet when supplied to the collation station along either path from the tray and the accumulation station respectively, from a generally horizontal disposition to an upwardly orientated disposition, and wherein said third path has a generally upward disposition. Such an arrangement avoids a layout for the internal components of an inserter, in which the front-to-rear external dimensions of the inserter are undesirably large. Furthermore, this arrangement effectively dictates that any folding arrangement (of an inserter including the collation apparatus that is required to feed the assembled collation be positioned in an upper

region of the inserter, which is desirable for reasons of layout and jam clearance of the folding arrangement.

[0021] The apparatus for collating sheets may be further provided with a folding arrangement comprising a first folder located in an upper region of said main housing for effecting a first fold following each sheet collation being delivered to the first folder along said third path and a second folder located in a rear region of said main housing to one side of said third path for effecting a second fold on each sheet collation, the second folder having an exit path for the folded collation that crosses said third path from the one side of that path to the opposite side.

[0022] Such a layout for the two folders reduces the "footprint" of the folding arrangement, while placing the two folders where they can readily be cleared of sheet jams without occupying space at the front of the inserter, which is needed for other functionality, i.e. the user/inserter interface.

[0023] A preferred form of apparatus further comprises a reader of a code on a control sheet when being fed to the collation station, said code denoting said predetermined number of sheet to form a collation, and control means responsive to the code determined by the reader to repeat the collation of sheet(s) from the accumulation station and the next successive sheet from the sheet feeding means, until said predetermined number of sheets is reached. By providing said control sheet with an appropriate code, it is possible to form collations with varying numbers of sheets in a single run of the collation apparatus, without the need to stop or reset the apparatus.

[0024] The apparatus for collating sheets may be provided with a further feeding means for feeding a respective sheet along a respective path to the collation station, for collation with the sheet collection formed from the sheets fed from the first mentioned feeding means.

[0025] According to the invention from a still further aspect, there is provided a method of collating sheets, comprising:

- (i) successively feeding a plurality of sheets one at a time along a first path to a collation station;
- (ii) transferring the sheet(s) at the collation station, after each feeding of a sheet to that station, along a second path to an accumulation station;
- (iii) returning the sheet(s) at the accumulation station to the collation station;
- (iv) collating those sheet(s) and the next of the successively fed sheets at the collating station, such collation being repeated until a sheet collation of a predetermined number of sheets is formed at the collation station; and
- (v) driving said collation of a predetermined number of sheets from the collation station along a third path.

[0026] The method for collating sheets may employ a

first feeding means for feeding the plurality of sheets to the collation station, and may further comprise the step of feeding a respective sheet from a second feeding means and along a respective path to the collation sheet, and collating the respective sheet with the sheet collation formed from the sheets fed from the first feeding means.

[0027] Embodiments of the invention will now be described with reference to the accompanying drawings, in which:

Figure 1 is a vertical side sectional view through one form of folder-inserter including one form of sheet collation apparatus in accordance with the present invention,

Figures 2a to 2e show diagrammatically successive stages in the double-folding of a sheet collation, Figures 3a to 3f are diagrammatic side views of the sheet collation apparatus, in successive operating conditions,

Figures 4a and 4b show a part of the vertical side sectional view of Figure 1, which illustrates how the flap of an envelope is opened,

Figure 5a and 5b are perspective views of a specific embodiment of the envelope flap opening mechanism of the folder-inserter,

Figure 6 is a schematic plan view of the envelope and a flapper blade of the flap opening mechanism of Figures 5a and 5b,

Figure 7 is a detailed cross-sectional view through a moistener tank and sealing station of the feeder-inserter according to Figure 1,

Figure 8 is an enlarged perspective view of a part of the folder inserter of Figure 1 where the moistener tank is located,

Figure 9 is a perspective view of the moistener tank withdrawn from the folder-inserter of Figure 1,

Figure 10 is a sectional view corresponding to Figure 7 wherein an inducer of the folder-inserter is in a second, lowered position,

Figure 11 is a general perspective view of the folder-inserter according to Figure 1,

Figure 11a shows a variant of the folder-inserter of Figure 11, having a second sheet feeder,

Figures 12a to 12f schematically describe in a sequence how a flap is sealed to a body of an envelope,- and Figure 12g illustrates an alternative four roller arrangement to the illustrated six roller arrangement, but which can perform an equivalent sequence,

Figure 13 is a diagrammatic side view of an envelope feeder of the folder-inserter and the flap opening mechanism,

Figure 14 is a flow chart relating to envelope feeding and sensing, and

Figures 15a and 15b together comprise a flow chart relating to a specific embodiment of envelope feeding, flapping and preparing for insertion.

[0028] Referring firstly to Figure 11, this shows an overall perspective view of a folder-inserter 100, as seen from the front and to one side, the folder-inserter being used for preparing a mailpiece. The folder-inserter comprises a main housing structure 2, at the front of which and at the bottom is located a sheet feeder 3 including a first sheet feeding tray 4 (feeding means). Above the sheet feeder 3 is an accumulation station 8 which is located under an output station 90 including an output tray 91. At the top of the folder inserter 100 is an envelope feeder 26 and, rearwardly thereof, an insert station 28 for feeding an optional insert sheet for the mailpiece to be prepared.

[0029] At the right side of the folder-inserter 100 at the front is a display and control unit 95 which provides an operator interface, by means of which an operator is able to control and use the folder-inserter from its front side.

[0030] In Figure 1, there are shown internal structural components of the tabletop folder-inserter 100, which includes a sheet collation apparatus 1 of a preferred form. It is to be understood that the tabletop folder-inserter 100 is not to be regarded as the only environment for use for the sheet collation apparatus of this form. Indeed, other environments involving sheet handling are envisaged, including in particular other forms of inserter or any other mechanism requiring a collation apparatus for collating sheets of paper. For this reason, the description to be given below of the inserter 100 is only of a general character.

[0031] The precise form of the housing structure is of no particular importance, though it will normally be designed so that one or more sections can be opened by pivoting, removal or the like for access to the internal components of the inserter for maintenance and jam clearances.

[0032] As shown in Figure 1, the sheet collation apparatus 1 includes the sheet feeder 3 provided in the lower section of the housing structure, the first sheet feeding tray 4 projecting forwardly from a front face of the inserter to enable an operator to periodically recharge the tray with fresh sheets, a separator wheel 5 and a pivotally mounted, cam operated, rocker arm 6 below the separator wheel 5, so that when pivoted into its raised position, it will urge the stack of sheets in the first sheet feeding tray 4 into engagement with the rotating separator wheel, which accordingly drives the uppermost sheet along a sheet feeding path 7.

[0033] Positioned above the first sheet feeding tray 4 is the sheet accumulation station 8 of the collation apparatus 1, for accumulating one or more sheets initially supplied from the first sheet feeding tray 4. A sheet transfer path 9 connected to the rear end of the sheet accumulation station 8 merges with the sheet feeding path 7 below a sheet collation station 10 of the collation apparatus 1. A sheet diverter or deflector 11 is pivotally mounted on pin 112 beneath the sheet collation station 10 and defines a lower guiding surface of the second,

sheet transfer, path 9, the deflector being biased in a direction (anti-clockwise in Figure 1) so as normally to be located blocking the first path. Sheet accumulation station 8 is preferably also designed as a "daily mail" tray into which so-called daily mail may be manually inserted for folding and inserting into a respective envelope. This daily mail may be a single sheet, or a number of sheets, which may or may not be stapled together, or some of which may be stapled together.

[0034] Sheets are successively fed one at a time from the sheet feeding tray 4 along the sheet feeding path 7. As the leading edge of each advancing sheet strikes the deflector 11, the latter is caused to pivot against its spring bias, thereby allowing the sheet to advance beyond the deflector to the collation station 10, at which the leading edge of the sheet is arrested in the nip defined between a pair of collation rollers 12 at the collation station, which are non-driven when the sheet is advanced into the roller nip but which are selectively drivable, in a manner to be described below. When one or more sheets from the sheet accumulation station 8 and a single sheet from sheet feeder 3 are both advanced into the collation nip, the leading edges of the plural sheets become aligned. Once a sufficient number of sheets have been aligned to form a collation of a required, predetermined, number of sheets, as will be described in more detail below, the collation rollers are driven simultaneously to advance the sheet collation along a third, sheet feeding, path 13 to a folding station 14.

[0035] An auxiliary sheet feeding path 33, extending upwardly from the underside of the inserter 100 and merging with the sheet feeding path 7, serves for connection to a separate sheet printing appliance, e.g. laser jet or ink jet printer disposed below the inserter, or a supplementary sheet feeding tray, for use in delivering printed sheets one at a time to the collation station for inclusion in each sheet collation formed at the collation station. This path 33 provides an alternative supply of printed sheets to that provided by the sheet feeder 4. The folding station 14 serves to form two folds in the collation fed along the third path 13 from the collation station 10. It comprises a first sheet folder 15 located in an upper region of the housing structure 2 for effecting a first fold on the sheet collation and a second sheet folder 16 located in a rear region of the housing structure rearwardly of the path 13, the second sheet folder serving to fold the once-folded collation a second time. A drive roller 17 of the sheet folder is in permanent driving contact with driven rollers 18-20.

[0036] The operation of the folding station 14 will now be described with particular reference to Figures 2a to 2e. The sheet collation A_1, A_2 advancing along the sheet feeding path 13 from the collation station is directed by a guide 21 into the nip of rollers 17, 18 (Figure 2a), which advances the collation into the first sheet folder 15, until the leading edge of the collation has reached a predetermined position in the sheet folder (Figure 2b).

[0037] Preferably, the first sheet folder includes a roller pair 22 which, as the advancing sheet enters the roller nip (which event may be detected optically or in any other suitable way such as will be known to the skilled person) applies drive to the roller pair over a predetermined angular rotation and then stops, to determine the predetermined stop position of the leading edge of the sheet collation. This "intelligent" nip provides a preferred way of determining the predetermined stop position of the collation leading edge, or in other words the location of the first fold to be made to the sheet collation. Other ways of achieving such arrestation of the collation will be apparent to the skilled person, such as a stop member provided with means for setting the position of that stop member as required.

[0038] When the collation has been arrested with its leading edge in the predetermined position, continuing drive imparted to the trailing section of the collation causes the section of the collation between the rollers 18, 19 and roller pair 22 to buckle rearwardly and enter into the nip between roller pair 17, 19, to form a first fold in the sheet (Figure 2c). The sheet collation is then advanced between the roller pair 17, 19 with its folded edge leading and into the second sheet folder 16.

[0039] This folder includes a manufacturer adjustable stop 23 (for the US or European market) which arrests the leading edge of the folded collation while the roller pair 17, 19 continues to drive the trailing section of the collation to cause the section between that roller pair and the folding station 14 to buckle forwardly and downwardly into the nip of the roller pair 17, 20, to form a second fold in the collation (Figure 2d). The position of the stop 23 determines the position of the second fold.

[0040] This roller pair 17,20 advances the double-folded sheet collation across the feed path 13 and into the nip of a further drive, driven roller pair 24, which advances the double-folded sheet collation along a further path 25 (Figure 2e) to a stuffing station 27 (Figure 1), to which an envelope from the envelope feeder 26 has been advanced. The arrangement produces a C-fold as schematically indicated in Figure 2e. Referring now to Figure 1, the envelope is thereby forwarded by a traction belt 41 along a path 42 to a roller pair 43 by which the envelope's flap is engaged with a flapper blade 44 so that the envelope is held rear face down and envelope flap open and trailing. The double-folded sheet collation is then driven into the waiting envelope until its leading folded edge engages the crease along the bottom edge of the envelope. Optionally, an insert sheet can be advanced from insert station 28, when the second fold in the collation is formed by the nip between roller pair 17, 20, which is then fed along the feed path 25 into the open envelope at stuffing station 27.

[0041] Thereafter, the stuffed envelope is driven successively to a moistener 29, which moistens the flap of the envelope, and to a sealing station 30. The sealing station 30 includes an inducer 50 which is moved towards a sealing roller pair 31, which is also part of the

sealing station 30 and which closes and seals the moistened flap against the rear panel of the envelope and ejects the thus-prepared mailpiece from the front of the folder-inserter 100.

[0042] The operation of the collation apparatus will now be described in more detail with reference to Figures 3a to 3f.

[0043] Figure 3a shows the top two sheets A_1 , A_2 of a stack of sheets held in the sheet feeding tray 4. A second sheet feeding tray indicated schematically at 34 may be disposed beneath the first sheet feeding tray as illustrated schematically in Figure 3a, either integrally with the rest of the folder-inserter as illustrated in Figure 11a, or as a "bolt-on" unit to that of Figure 11. The construction and basic operation of tray 34 may be equivalent to that of tray 4, with a respective feed path 35 leading to the collation station. At the beginning of an operational cycle, the cam operated rocker arm 6 (shown only in Figure 1) pivots upwardly to cause the driven separator wheel 5 to apply drive to the uppermost sheet A_1 , which accordingly is driven from the sheet feeder along path 7, past the spring biased diverter 11, and into the nip of stationary collation rollers 12 (see Figure 3b). The leading edge of sheet A_1 is arrested in the collation nip and drive is removed from the trailing edge of the sheet.

[0044] After a brief pause, drive is applied to the rollers 12, to advance the sheet A_1 along path 13 until the trailing edge of the sheet has cleared the deflector 11, which again returns under spring bias to its position blocking the feed path 7. Drive is then removed from the collation rollers to hold the sheet A_1 stationary in this position (Figure 3c). The trailing edge of sheet A_1 moving clear of deflector 11 can be detected in any suitable manner, e.g. optically.

[0045] Following a further pause, the rotational direction of collation rollers 12 is reversed. The advancing edge of the sheet initially strikes deflector 11, which diverts the sheet along transfer path to accumulation station 8, at which a pair of rollers 32 in vertical driving contact take over advancement of sheet A_1 until it is brought to rest (Figure 3d).

[0046] Drive is then applied both to separator wheel 5 of sheet feeder 4 and roller pair 32 of accumulation station 8, to advance the next sheet A_2 and the initial sheet A_1 , respectively, along paths 7,9 and into the collation nip of collation rollers 12 to align their leading edges, thereby forming a collation of two sheets (Figure 3e).

[0047] If a collation of three or more sheets is required, the above described operational steps are repeated, where the sheet collation A_1 , A_2 is handled as described above for the initial sheet A when at the collation station (Figure 3b), and a collation is formed between the collation A_1 , A_2 and the next sheet (A_3) from the sheet feeder 4 to form collation A_1 , A_2 , A_3 , such procedure being repeated until the collation consists of the required number of sheets. Thereafter, the collation rollers 12 are driven to advance the collation A_1 , A_2 ... etc along path 13 from the collation station 10 to the folding station 14

(Figure 3f).

[0048] In an alternative method of operation, the second sheet feeding tray 34 can be used as the main sheet feeder and thus feeding paper to the accumulator tray 8, and with the first tray 4 used for adding a single sheet to be collated therewith.

[0049] Referring now to Figures 4a, 4b, 5a, 5b and 6, the opening of the flap of an envelope will be described in more detail.

[0050] A plurality of envelopes are stored unflapped in a stack in the envelope feeder 26 (Figure 1), and orientated with their rear faces towards the traction belt 41 and the envelope flaps uppermost and furthest from the path 42. (See also Figure 12, and the corresponding description thereof, for a schematic view of the layout). By actuating the traction belt 41, a single unflapped envelope is fed downwards along path 42 into the nip of roller pair 43. The roller pair 43, which includes an arching roller 43a, drives the envelope further downwards until the trailing edge of the envelope passes a deflecting edge 45 of the fixed flapper blade 44. The drive of the roller pair 43 is then reversed so that the trailing edge becomes the leading edge and the envelope is forced by a diverter element 39 facing the arching roller 43a to come into contact with a deflecting surface 46 of flapper blade 44. The envelope is caused to follow the curvature around the arching roller 43a as a result of the deflecting surface 46 of flapper blade 44, and is driven along a flapper path which adjoins the path 42 until the flap is completely within a flapping chamber 47 or zone. Optionally, deflector means 48 are arranged inside the flapping chamber 47 to slightly spread the flap apart from the envelope, and initiate and facilitate flap opening, since the envelope is buckled downwards by the deflector means 48. The contact of the envelope with the deflector means 48, which have an angled guide part 48a, might serve as an indicator to reverse the feed direction of the envelope again. For example, a movement of the deflector means 48 around part 48a may indicate contact with the envelope 60 when its flap 61 is completely within the flapping chamber 47, as shown in Figure 4a. When reversing the feed direction back again, the partially opened flap 61 of the envelope 60 is now engaged by the flapper blade 44, so that the flap is stripped away from the body of the envelope. As the envelope is driven further by roller pair 43, which is disposed downstream of the junction between the flapper path and path 42, the flap 61 is completely opened by sliding on an opening surface 49 of the flapper blade 44, as shown in Figure 4b, and being drawn between the arching roller 43a and the deflecting surface 46 of flapper blade 44. Thus, the envelope is fed into path 25 with an open flap to receive the double collation sheet at the stuffing station 27, where spring biased fingers (not shown) hold the envelope open.

[0051] In Figures 5a and 5b two embodiments of flapper blade 44 are illustrated. Figure 5a shows a flapper blade 44 comprising four plate-like blade parts or ele-

ments 44a,44b each having a flap opening surface 49. The two inner blade parts 44a are equally spaced apart from the central line of an envelope so that the tip of the flap is arranged between those two blade parts 44a, which are held at a fixed height position above the arching roller 43a. See also Figure 6.

[0052] In Figure 5b an envelope with flap 61 is shown which is deflected by two deflectors 48, positioned at the right and left edge of the envelope, to partly open the flap of the envelope on being engaged by the deflectors 48. The embodiment of Figure 5b illustrates a six part flapper blade 44 in the form of pairs of plate-like blade parts 44a, 44b, 44c. The blade parts 44b of both embodiments, and parts 44c of the embodiment of Figure 5b, serve as guide elements, whereas the opening of the envelope is performed by the two inner blade parts 44a. The gap between the two inner blade parts 44a allows the amount of travel of envelope inside the flapping chamber 47 to be reduced by the amount indicated by two arrows in Fig. 6, since the tip of the flap is disposed between the inner blade parts 44a, which are spaced apart from each other. Thus, the individual flap length of different envelopes does not have to be considered, as schematically illustrated in Figure 6.

[0053] With reference to Figures 7, 8 and 9, it will now be described how liquid is transferred onto an envelope flap for use in sealing it to the body of an envelope. Alternatively, the liquid could be used to moisten the body of the envelope.

[0054] As can be seen in Figure 7, liquid is stored in a moistener tank 70 in which a capillary action fitted wick 71 is accommodated and serves to deposit liquid onto the flap of an envelope from underneath. The moistener tank 70 comprises a tank housing 72, generally U-shaped in cross-section, which forms a space to store the liquid. The tank housing 72 is placed in a watertight channel 75 by means of which leaking liquid can be collected and led away from the interior of the folder-inserter 100.

[0055] The liquid level in the moistener tank 70 is visible to an operator at the front of the folder-inserter 100 through a transparent window 73, which can comprise a scale to indicate how much liquid is contained in the moistener tank 70. For this purpose, the transparent window 73 is arranged substantially on the same level at which the liquid is surrounding the wick 71 inside the moistener tank 70, with folder-inserter 100 placed on a horizontal surface. Thus, the transparent window 73 indicates to the operator when the tank needs to be refilled with liquid.

[0056] If the operator wants to refill the moistener tank 70, the moistener tank 70 can be partially removed from the housing structure 2 of the tabletop inserter 100 by pulling it out to the side in a horizontal direction, as indicated by the two arrows in Figure 8, until it reaches a detent position. In this detent position, the moistener tank 70 protrudes out of the housing structure 2 so that a refill opening 76 is exposed and liquid can be poured

into the opening 76 from above. For this refilling, the moistener tank 70 comprises a recess 74, which can be manually engaged for pulling the tank out of the side of the housing structure 2.

[0057] As can be seen in Figure 9, a plurality of wicks 71 are arranged in a line to deposit liquid onto the flap of an envelope. The tank housing 72 is covered by a plate like cover 78 which has openings 79 through which the tops of the wicks 71 protrude upwards out of the vessel which is formed by the tank housing 72 and the cover 78. If the wicks are contaminated with envelope gum due to a long use, the used wicks can be replaced by new ones, simply by pulling them upwards out of the tank 70 and loading new wicks by dropping them down through the corresponding openings 79 of the cover 78. This can be achieved by the operator when the moistener tank 70 is completely removed from the housing structure 2. Thereafter the moistener tank 70 has to be inserted again into the watertight channel 75 starting with a first portion 70a of the moistener tank 70 which has an elongate shape and accommodates the wicks 71. A second portion 70b of the moistener tank 70 is substantially perpendicularly arranged to the first portion 70a and includes the opening 76, the transparent window 73 and the recess 74. In the partly-removed detent position of the moistener tank 70, substantially only the second portion 70b of the moistener tank 70 protrudes in a horizontal direction out of the housing structure 2, in order to allow refilling of the tank 70 with liquid. This detent position of the moistener tank 70 is reached if a plurality of clips 77 have been snapped in corresponding recesses in the watertight channel 75. When the moistener tank 70 is completely inserted back again into the housing structure 2, the clips 77 will have snapped in corresponding further recesses in the watertight channel to achieve a predetermined position of the moistener tank 70 and depositing of liquid onto the envelope flaps by the capillary action of the wicks. The face of the tank including the window thus forms part of a face of the housing in operation of the apparatus.

[0058] The procedure for moistening the flap of an envelope within the folder-inserter 100 will now be described. As described above, the folded collation sheets are inserted into the envelope within feedpath 25 at the stuffing station 27. The envelope is then transported by a driven roller 31a of roller pair 31, which is cooperating with a not shown driven roller mounted on the end of pivotable support arm 80, to pass the envelope over the moistener tank 70. The arm 80 pivots under the action of a cam (not shown), about a pivot point 81. Above the moistener tank 70, in particular above the openings 79 of the cover 78 in which the wicks 71 are accommodated, a deflector 85 is arranged to bring the flap of the envelope into contact with the wicks 71 when required to moisten adhesive therein. The deflector 85 pivots about a pivot point 82 and is moved downwards only at that time. Transport of an envelope etc. through this zone is assisted by a drive roller 88. A plurality of later-

ally-spaced lightly-sprung fingers 89 over which the envelope is transported serve to keep the envelope flap away from the wick and prevent it being moistened, except when the deflector is actuated. If an envelope is not moistened it will merely be closed rather than sealed at the subsequent sealing station. The deflector is solenoid-operated by the crease datum position detector (sensor) described hereinafter. By pivoting the deflector about its pivot point 82, it is moved downwards so that the flap is brought into contact along the wicks 71 for depositing liquid thereonto. Additionally, spring biased perforated elements can be arranged between the envelope and the wicks which are pressed down by the movement of the deflector 85 so that the wicks 71 are protected from excessive wear due to unnecessary contact of the wicks with the envelope.

[0059] Before the preferred embodiment of sealing an envelope is described with respect to Figures 7 and 10, a general concept for sealing the flap of an envelope to the body of an envelope will be explained, for a better understanding, with reference to Figures 12a to 12f, which schematically describe in a sequence how the flap can be sealed to the body of the envelope.

[0060] In Figure 12a it is shown that a body 62 of the envelope is transported by a first roller pair 131 in a direction leading the envelope to the vicinity of a sealing roller pair 132 as shown by the corresponding arrows.

[0061] As can be seen from Figure 12b, a buckle roller pair 133 is arranged downstream from the first roller pair 131 and the sealing roller pair 132, with an engageable roller 133b of the buckle roller pair 133 spaced apart from a fixed roller 133a of the buckle roller pair 133. The buckle roller pair 133 is in this position until a crease line 63 connecting the flap 61 with the body 62 of the envelope is substantially arranged underneath the sealing roller pair 132.

[0062] As indicated by Figure 12c, the engageable roller 133b is brought into contact with the fixed roller 133a in response to a signal, when the crease line 63 of the envelope has been transported underneath the nip of sealing roller pair 132. Also, although not shown in Figures 12a to 12f, the engageable roller 133b is preferably arranged on an inducer which includes a protrusion that supports the movement of the crease line towards the nip of the sealing roller pair 132, when the engageable roller 133b is brought in contact with the fixed roller 133a, as will be described with reference to Figures 7 and 10.

[0063] Figure 12d shows that the buckle roller pair 133 transports the envelope in a direction substantially opposite to the direction of the transporting roller pair 131 which is engaged with the flap 61 of the envelope. As a result of the movement of transport roller pair 131 and buckle roller pair 133, the crease line 63 of the envelope is inserted into the nip of sealing roller pair 132. Thereafter, the envelope is closed by pressing the flap 61 and the body 62 from opposite sides by sealing roller pair 132 as shown in Figure 12e.

[0064] As further indicated by Figure 12f, the whole envelope is transported by sealing roller pair 132 upwards to an output as shown by the corresponding arrows.

[0065] In an alternative embodiment of the concept for sealing the envelope, the buckle roller pair 133 can be replaced by a clamp (not shown) which holds the body 62 of the envelope by engaging clamp parts with the envelope from opposite sides while it is moved along in the transport direction, so that the envelope buckles. As a result, the crease line is inserted into the nip of the sealing roller pair 132 by transporting the envelope by means of transport roller pair 131. Thereafter, when the crease line is engaged with the sealing roller pair 132, the clamp will be released from the body of the envelope so that the flap can be sealed to the body of the envelope as shown in Figures 12e and 12f.

[0066] As will be apparent to a skilled person, the buckle roller pair can alternatively be driven significantly slower than the transport roller pair 131, whereby to insert the crease line into the nip of the sealing roller pair 132. Additionally, it is obvious that the flap of the envelope can be first transported through the transport roller pair 131, that is the envelope can be moved with the flap leading, rather than the body leading. Furthermore, and as is the case for the embodiment described hereinafter with reference to Figures 7 and 10, each roller of the sealing roller pair 132 can respectively serve as a roller of the transport roller pair 131 and the buckle roller pair 133, so that a minimum of four rollers is required for sealing the envelope, as will now be described.

[0067] A preferred embodiment for sealing the flap to the body of an envelope will now be described with reference to Figures 7 and 10. Figure 10 shows the inducer 50 in a lowered, second position in which the inducer is not engaged with the envelope. The flap of the envelope on which liquid has been deposited from the moistener tank 70 has now to be closed and sealed to the body of the envelope. As described, the roller 31a and a roller (not shown) at the end of the support arm 80 comprise first transport means which transport the envelope with the flap facing downwards at the trailing end of the envelope to the sealing station 30. The sealing station 30 comprises the inducer 50 and the sealing roller pair 31, including the drive roller 31a by which the envelope is transported to the sealing station 30. The inducer 50 of the sealing station 30, which can be formed as a one-piece component, has a curved transverse elongate guide portion 51 at one end of which and on one side of which a transverse protrusion 52 is located. On the other side of the portion 51 to the protrusion 52, the inducer 50 has a transverse rectangular portion 57 which extends away from the protrusion 52 and is substantially at a right angle at the protrusion 52, as viewed in side elevation. At the part of the rectangular portion 57 extending away from the protrusion 52, there is mounted a roller 53 which in a raised, first position of the inducer 50 is engaged with sealing roller 31b, as illustrated in

Figure 7 (engaged position). In Figure 10, the inducer 50 is illustrated in the lowered, second position, in which the roller 53 is not engaged with the sealing roller 31b. Roller 53 and drive roller 31b comprise a second transport means (envelope buckling means) and rollers 31a and 31b comprise sealing means. Figure 12g illustrates a four roller arrangement, using the reference numerals of Figures 7 and 10, in a schematic manner and analogous to Figures 12c to 12d, rather than the six roller arrangement shown therein. The roller which is not visible in Figures 7 and 10 is indicated as roller 83 in Figure 12g.

[0068] The function and operation of the inducer 50 will now be described in more detail. After liquid has been added to the flap of the envelope from the moistener tank 70, the envelope with the envelope body leading is transferred to the sealing station 30. At that time the inducer 50 is in its lowered, second position (idle position) as shown in Figure 10. The drive roller 31a and the roller (not shown) at the end of the support arm 80 transport the leading edge of the envelope body beyond the sealing roller pair 31 until the crease line of the envelope, which is the line that is formed between the flap and the body of the envelope, is located before or substantially over the protrusion 52 of the inducer 50. Then, the inducer is actuated by pivoting upwards around a fixed rotation axis 54 so that the crease line of the envelope is forced (pushed) towards and into the sealing nip of the sealing roller pair 31. The protrusion 52 thus supports the crease line, which is to be inserted into the nip of roller pair 31. In particular, drive roller 31a, which rotates in Figures 7 and 10 in counter-clockwise direction, engages with sealing roller 31b, so that sealing roller 31b rotates in Figures 7 and 10 in clockwise direction. Due to these rotation directions of sealing roller pair 31, the body of the envelope, which is urged upwards by the rotation of the sealing roller 31b and the roller 53 carried by the inducer 50, and the flap, which is urged upwards by the drive roller 31a and the roller (not shown) at the end of support arm 80 in a somewhat opposite direction to the envelope body, if the flap is still driven thereby, form a buckle. The tip of which is at the crease line of the envelope, which buckles upwards and thus forms the first part of the envelope that is inserted into the nip of sealing roller pair 31. In any event, the buckling at the crease line upwards is supported by curved portion 51 of the inducer 50 and the protrusion 52.

[0069] After the crease line of the envelope has been inserted in the nip of sealing roller pair 31, the envelope is moved further upwards by the sealing roller pair 31 so that the flap is closed and sealed against the body of the envelope. The closed envelope is directed upwards by the roller pair 31 to an ejection roller 87 and the envelope pivots roughly the order of a right angle around a turning axis 86 as it exits the interior of the folder inserter 100, so that it falls downwards onto the output station 90, landing with the envelope flat on the output tray 91.

[0070] If the inducer is in its raised, first position, the

inducer 50 further acts as a diverter if only folded sheets are to be ejected out of the tabletop inserter and no envelope is required. For this purpose, the curved portion 51 corresponds substantially with the curvature of the drive roller 31a, and the protrusion 52 is substantially arranged underneath the nip of roller pair 31.

[0071] However, if the inducer 50 is used for sealing a flap to the envelope, the envelope starting with its leading edge begins to exit the folder inserter 100 at a casing opening 55 of housing structure 2, when the inducer 50 is in its lowered, second position. Subsequently, the crease line of the envelope is brought into contact with the sealing roller pair 31 by raising the inducer 50, and sealed, as described above, and the envelope directed upwards to turning point 86 and ejected out of the housing structure 2. The ejected envelopes are stored at output station 90. Since the crease line of the envelope is inserted between the two sealing rollers 31 due to the inducer movement upwards to the raised position, and even though the envelope may have begun to exit the housing structure 2 via opening 55 before the inducer 50 pivots around rotation axis 54 from the lowered to the raised position, it is not necessary to know the length of the envelope, since the crease line of the envelope is taken as the determining factor. Thus, envelopes with different sizes can be accommodated since they are sealed with reference to the position of the crease line, which can be detected as described further on. This sealing method, with or without the inducer can also be applied to envelopes fed with the flap leading, rather than trailing.

[0072] As already described, the closed envelopes exit the housing structure 2 of the folder inserter at an opening which is not specifically indicated in Figure 11. The opening for ejecting the closed envelopes is underneath the plurality of ejection rollers 87 which are shown in Figure 11.

[0073] The selective driving of the various rollers, in one or the other direction, or both, as well as the timing of the various operations is effected by a controller (not shown), which may for example be run under micro processor control.

[0074] For optimum functioning of the folder inserter 100, it is required that the envelope is appropriately positioned for the flapping, insertion, moistening and sealing operations, and in the case of moistening, that the deflector 85 is moved when the envelope flap is in the appropriate position, and in the case of the sealing operation that the inducer 50 is brought into its raised position at the appropriate time.

[0075] Referring now to Figure 13, a sensor 93 which employs a photosensor 99, a light source (not shown) and means 94 for interrupting the optical path therebetween, in order to detect an envelope in the envelope feed path 42. The envelope feeder (26 in Figure 1) has traction belt 41. Roller pair 43 serves to drive a fed envelope towards the insertion area 27 (stuffing station in Figure 1), back around the path 98 to the flapper blade

44 and flapping chamber 47, and subsequently into the insertion area, as described above. The roller pair 43 is driven by a stepper motor (not shown). When an envelope 60 is fed by belt 41 along the envelope feed path and towards the insertion area (step 102 of Figure 14), a pivotably mounted diverter 96 first detects its leading edge (step 103) and then detects its trailing edge (step 104), which for an unflapped envelope corresponds to the crease line. This is as a result of a flag 94 moving between the light source and the photosensor, since it moves with the diverter, and serving to interrupt or open the optical path therebetween, depending on the relative position of the flag and the sensor. The stepper motor is stopped when the trailing edge is detected (optical path interrupted again) and the position the trailing edge (crease line) adopts is set as a datum position (datum point or predetermined reference position) for the trailing edge (crease line) (step 105).

[0076] The length of the path between the datum position of the trailing edge (crease line) and the flapper blade 44 is a fixed distance (predetermined distance) and is the same for all envelope lengths. Hence the stepper motor will have to be driven (in the reverse direction) a fixed number of steps to position the trailing edge (crease line) of the envelope appropriately for the flapper blade, that is a predetermined reverse drive flapper count. The length of the path between the flapper blade 44 and the insertion area 27 is also a fixed distance and similarly means that the stepper motor will have to be driven (in the original direction) a respective fixed number of steps (a respective count) to the insertion area. Similarly, the distance the crease line of an envelope will have to be moved from the insertion area 27 to the sealing station 30 will be the same for all lengths of envelopes, and hence a respective stepper motor providing that movement will be stepped a respective fixed number of times, irrespective of the length of the envelope. Since the respective number of steps necessary to move the envelope to each area or station is fixed, correct coordination of the movement of other members at those areas or stations, such as the deflector 85 and the inducer 50 is facilitated. As indicated at step 106 of Figure 14, embedded software can be provided to perform the steps to drive the step motor(s) for the predetermined fixed numbers of counts, and in the appropriate drive directions. The steps for a practical envelope movement process will include additional steps such as checking the envelope feed and sensor operation for errors, incorporating delays between the driving steps, and setting flags to indicate completed stages, thereby permitting related events to proceed. With reference to Figures 15a and 15b, which together comprise a single flow chart, a specific embodiment of a program for envelope feeding, flapping and preparing for insertion will now be described. The reference numerals used in Figure 13 for the envelope feeder (41), the sensor (93) and the roller drive (43) have also been used in Figures 15a and 15b.

[0077] The routine starts with driving the feeder 41 and the roller pair 43 (step 150). A query is made 151 regarding whether or not the sensor has been made, namely has the sensor detected the presence of an envelope, if not a sequence 154-158 determines if the envelope has been driven for long enough, if there is an error or attempts a restart of feeder 41. If the sensor has detected an envelope a flag is set 152 which can be used for other purposes, and the feeder 41 driven 153 for the appropriate time so that the sensor can detect the trailing edge of the envelope, namely the crease line, at 159. Failure to detect at this stage can result in an error message and includes checking that the envelope was driven for long enough 160. If the sensor is clear the roller drive 43 is driven for a predetermined time corresponding to a clearance count 161, is stopped 162, reversed 163, the reverse state indicated, and the envelope driven in the reverse direction (up the flapper path) for a predetermined time 164 and after a short delay 165, driven forward 166 a predetermined time so that the envelope is flapped and driven to the insertion point in one step. A flag is set 167 to indicate the envelope has been flapped and this flag can be used for other purposes i.e. to start other processes. A query is raised at 168 regarding the completion of the insertion counts and roller pair 43 is stopped 196, an envelope complete flag set 170, which indicates that the envelope is in the stuffing (inserting) position, fingers for throating the envelope are driven 171, and the drive for roller pair 43 reversed for a predetermined time to pull the envelope back onto the fingers 172.

[0078] As will be appreciated, all distances to be traversed are measured from a datum point corresponding to the position of the trailing edge (crease line) of the envelope at a particular point in the process and thus are independent of the length of the envelope. The same amount of movement, provided by a roller or other drive means, will be needed to move an envelope of any length of envelope between one particular operation area and the next. Whereas in the above description the process involves stopping the envelope when its trailing edge is detected and the datum point set, stopping is not necessary and the sensor position can be defined as the datum position and the distance to the next operation station measured from it. Whereas the above description specifically refers to a process involving the movement of envelopes of various lengths, it will be appreciated that the same principle, that is sensing the trailing edge of any elongate element, or article with leading and trailing edges, can be used in a corresponding multi-operation process which can accommodate elongate elements of various lengths. Indeed, the same principle can be applied to the detection of leading edges and movement of the leading edges of articles by predetermined amounts between operation stations. Further, rather than using a stop in the folding process as described above, a trailing edge detection and controlled subsequent movement arrangement could be em-

ployed.

[0079] It is to be understood that the use of the collation rollers represent one particular preferred way of aligning the sheets of the collation. However, other ways of achieving this result are also contemplated, such as movable stops.

[0080] It will be appreciated that the described collation apparatus is of simple construction, requires minimal operator effort to reload the sheet feeder and is able to assemble any number of sheets to form each collation, without needing a corresponding number of sheet feeders.

[0081] Furthermore, the layout of the principal internal components of the inserter results in an extremely compact and ergonomic arrangement, especially due to the design of the collation apparatus with only a single feeding tray, the space-saving design of the folding station with its crossing sheet paths, and the way in which the feed and transfer paths from the sheet feeder and accumulation station, respectively, reorientate the sheets from approximately horizontal to substantially vertical, which largely determines or at least restricts the positions of the first and second folders and feed tray to be desirably configured from an accessibility standpoint whilst maintaining a compact layout.

[0082] It will be appreciated that the described sheet folding apparatus is of simple and compact construction, locates its folders in convenient positions for access, employs generally straight paths for the passage of the sheet collation and relies on the folding rollers of the sheet folders to achieve the required re-orientations of the collation. Positioning the sheet folders in upper and rear sections of the inserter housing avoids the need to provide access to them from the front of the inserter, where the control panel and operator interface are necessarily provided.

[0083] Although the described sheet folding apparatus serves to double-fold (C-fold) a sheet collation comprising a plurality of sheets, it will be appreciated that it could be used instead to double-fold a single sheet.

[0084] In known manner, (i.e. by adjusting the settings of the first and second sheet folders), it is possible to adjust the type of fold, such as Z-fold or double fold (i.e. fold in half and in half again). It is possible to fold the sheet or sheet collation only once.

[0085] As will be appreciated the design of the moistener involves a one piece moistener tank, which is a low-cost component, which readily allows the user to see when liquid needs to be added due to the window, which is easily removable for cleaning purposes, for replacement of the wicks or the whole tank structure, and which is easily partially removed for the addition of liquid.

[0086] The apparatus for sealing envelopes is low cost and able to accommodate envelopes of various sizes, since it is the position of the creaseline which determines (controls) the operation. Excessively long envelopes do not require the apparatus to be extended in

length, rather they can emerge through the opening 55 temporarily prior to the actual sealing, if fed with the body at the leading edge. The use of one roller from each of the two transport means to form the sealing roller pair also reduces the cost and the space required in comparison with use of a separate sealing pair.

Claims

1. Apparatus for collating sheets, comprising:
 - (i) a collation station;
 - (ii) feeding means for successively feeding a plurality of sheets one at a time along a first path to the collation station;
 - (iii) an accumulation station;
 - (iv) transferring means for transferring the sheet(s) at the collation station, after each feeding of a sheet to that station, along a second path to the accumulation station;
 - (v) sheet returning means associated with the accumulation station for returning the sheet (s) at the accumulation station to the collation station;
 - (vi) means at the collation station for collating those sheet(s) and the next of the successively fed sheets, such collation being repeated, in operation of the sheet collating apparatus, until a sheet collation of a predetermined number of sheets is formed at the collation station, and
 - (vii) first driving means for driving said collation of a predetermined number of sheets from the collation station along a third path.
2. Apparatus for collating sheets according to claim 1, wherein the collation station is provided with a pair of collation rollers defining a nip and power means operable for rotatably driving the rollers, the nip of the rollers, when the latter are not driven, serving for effecting the collation of sheets at the collation station when driven into the nip and the rollers being drivable in association with second driving means of the accumulation station for selectively effecting the transfer of sheet(s) to the accumulation station and the driving of said collation from the collation station along the exit path, the second driving means being reversible for effecting the return of the sheet(s) at the accumulation station to the-collation station.
3. Apparatus according to claim 2, wherein the first and second paths merge ahead of the nip of the collation rollers and the collation station includes a diverter movable between a first position for permitting the feeding of each sheet along the first path to the collation station and a second position for diverting the sheet(s) along the second path during the

transfer thereof from the collation station to the accumulation station.

4. Apparatus for collating sheets, comprising:

(ix) a collation station including a pair of rollers defining a nip;

(x) power means operable for selectively applying drive to the rollers;

(xi) feeding means for feeding a plurality of sheets one at a time along a first path to the collation station and into the nip of the rollers when they are non-driven;

(xii) an accumulation station, there being a second path interposed between the accumulation station and the collation station; and

(xiii) a diverter positioned between the first path and the collation station and movable between a first position permitting the feeding of each sheet along the first path to the collation station and a second position;

wherein

(xiv) the power means is arranged to apply drive to the rollers to initially drive the sheet(s) located in the nip of the roller along a third path from the collation station in one direction until the trailing edge of the sheet(s) moves clear of the diverter, whereafter the direction of drive is reversed, the diverter which is then in its second position diverting the sheet(s) along said second path to the accumulation station;

(xv) the accumulation station has driving means operable for selectively applying drive to the sheet(s) diverted to the accumulation station and for thereafter returning the sheet(s) along the second path to the collation station at which the nip of the rollers, which are then non driven, collates those sheets and the next of the successively fed sheets; and

(xvi) such collation is repeated, in operation of the sheet collating apparatus, until a sheet collation of a predetermined number of sheets is formed at the collation station, the power means then being arranged to apply drive to the rollers to drive the collation along the third path in said one direction.

5. Apparatus for collating sheets according to any preceding claim, wherein the feeding means comprises a generally horizontally arranged tray for a stack of sheets, and a feeder for feeding one sheet at a time from the tray to the collation station, and wherein said tray is arranged in a lower region within a main housing of the apparatus, the accumulation station being located above the tray.

6. Apparatus for collating sheets according to any preceding claim, wherein the accumulation station is

arranged also to serve as a daily mail feeder.

7. Apparatus for collating sheets according to any preceding claim, further comprising an auxiliary sheet feeding path for connection to a sheet printing apparatus or a supplementary sheet feeding tray for use in delivering printed sheets supplied one at a time from the printing apparatus or supplementary sheet feeding tray, to the collation station.

8. Apparatus for collating sheets according to claim 5, 6 or 7 as appended to claim 2 or 4, wherein the driving means of the accumulation station comprises a pair of rollers defining a nip.

9. Apparatus for collating sheets according to claim 5 or any one of claims 6 to 8 as appended to claim 5, wherein the first and second paths are so arranged as to reorientate each sheet when supplied to the collation station along either path from the tray and the accumulation station respectively, from a generally horizontal disposition to an upwardly orientated disposition, and wherein said third path has a generally upward disposition.

10. Apparatus for collating sheets according to claim 9, and further provided with a folding arrangement comprising a first folder located in an upper region of said main housing for effecting a first fold following each sheet collation being delivered to the first folder along said third path and a second folder located in a rear region of said main housing to one side of said third path for effecting a second fold on each sheet collation, the second folder having an exit path for the folded collation that crosses said third path from the one side of that path to the opposite side.

11. Apparatus according to any preceding claim, further comprising a reader of a code on a control sheet when being fed to the collation station, said code denoting said predetermined number of sheet to form a collation, and control means responsive to the code determined by the reader to repeat the collation of sheet(s) from the accumulation station and the next successive sheet from the sheet feeding means, until said predetermined number of sheets is reached.

12. Apparatus for collating sheets according to any one of the preceding claims, and including a further feeding means for feeding a respective sheet along a respective path to the collation station for collation with the sheet collation formed from the sheets fed from the said feeding means.

13. Apparatus for collating sheets, substantially as hereinbefore described with reference to Figures 1,

and 3a to 3f of the accompanying drawings.

14. A method of collating sheets, comprising:

- (i) successively feeding a plurality of sheets one at a time along a first path to a collation station; 5
- (ii) transferring the sheet (s) at the collation station, after each feeding of a sheet to that station, along a second path to an accumulation station; 10
- (iii) returning the sheet(s) at the accumulation station to the collation station;
- (iv) collating those sheet (s) and the next of the successively fed sheets at the collating station, such collation being repeated until a sheet collation of a predetermined number of sheets is formed at the collation station; and 15
- (v) driving said collation of a predetermined number of sheets from the collation station along a third path. 20

15. A method of collating sheets as claimed in claim 14 and wherein the plurality of sheets are fed from a first feeding means, and further comprising the step of feeding a respective sheet from a second feeding means and along a respective path to the collation station for collation with the sheet collation formed from the sheets fed from the first feeding means. 25

16. A method of collating sheets, substantially as hereinbefore described with reference to Figures 1, and 3a to 3f of the accompanying drawings. 30

35

40

45

50

55

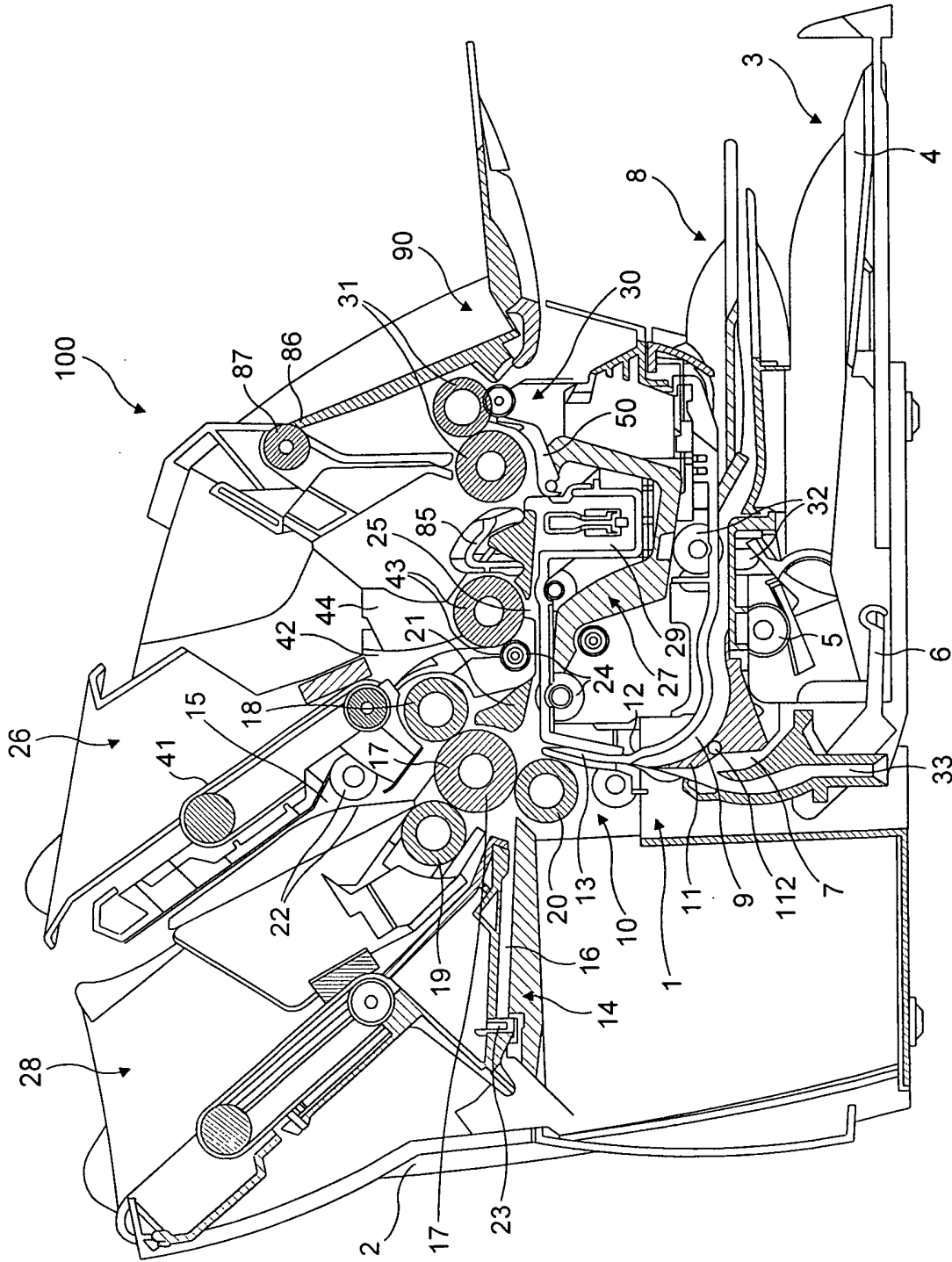
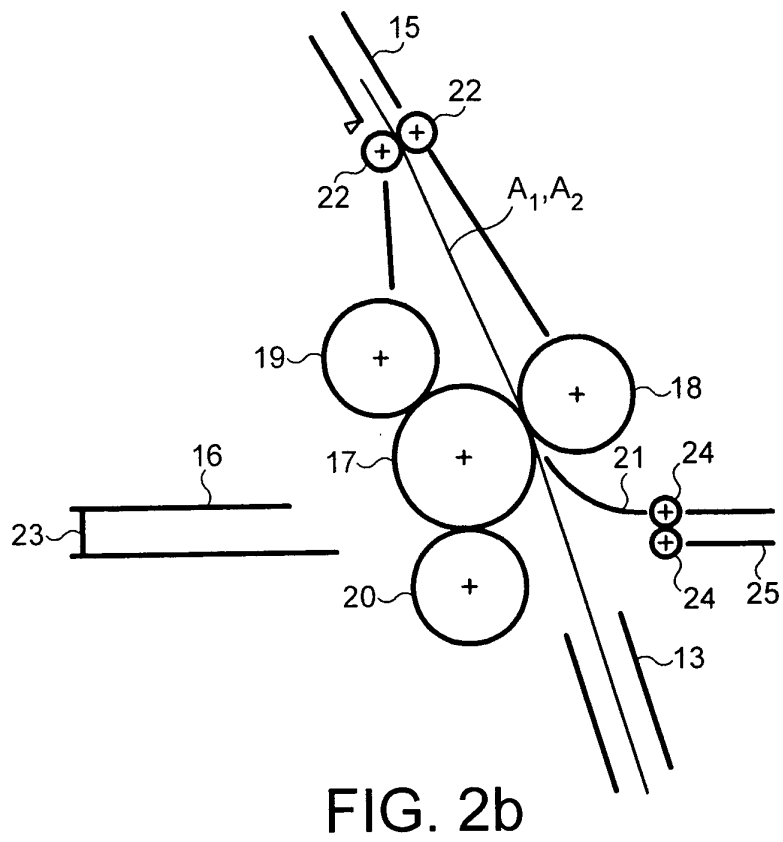
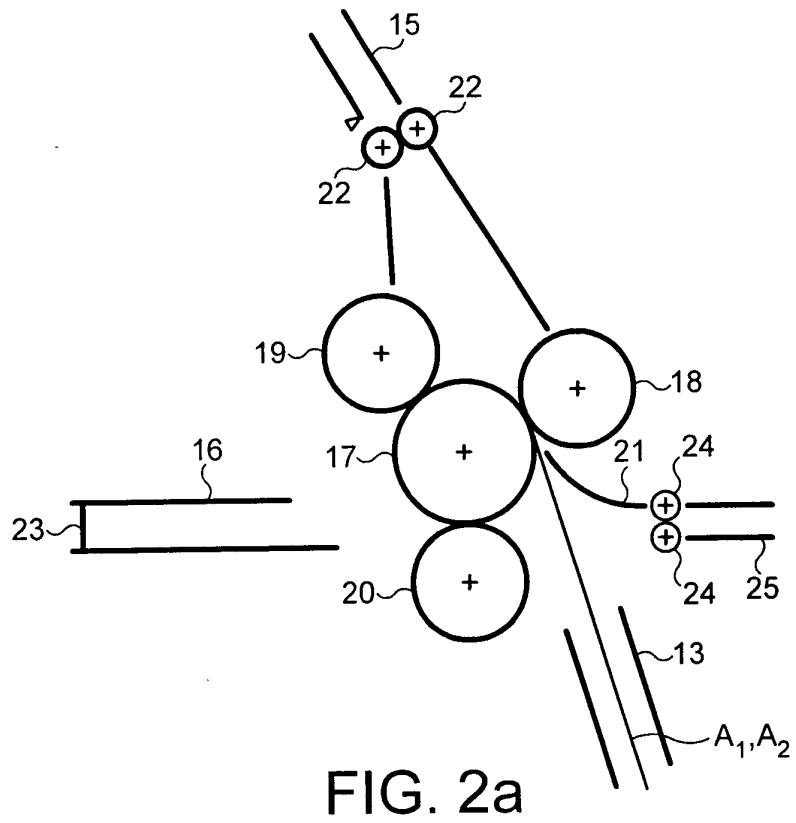

FIG. 1



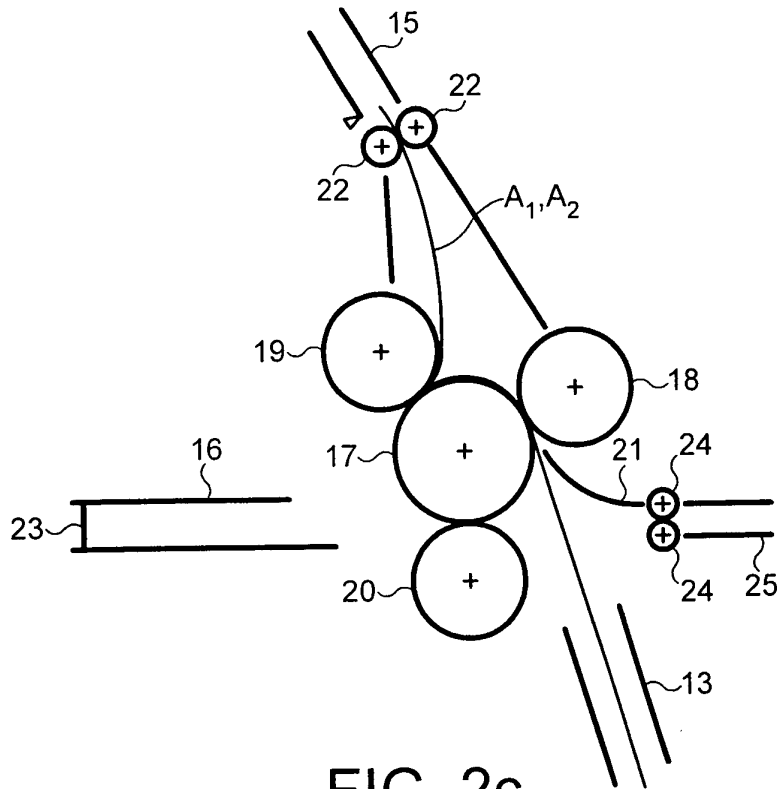

FIG. 2c

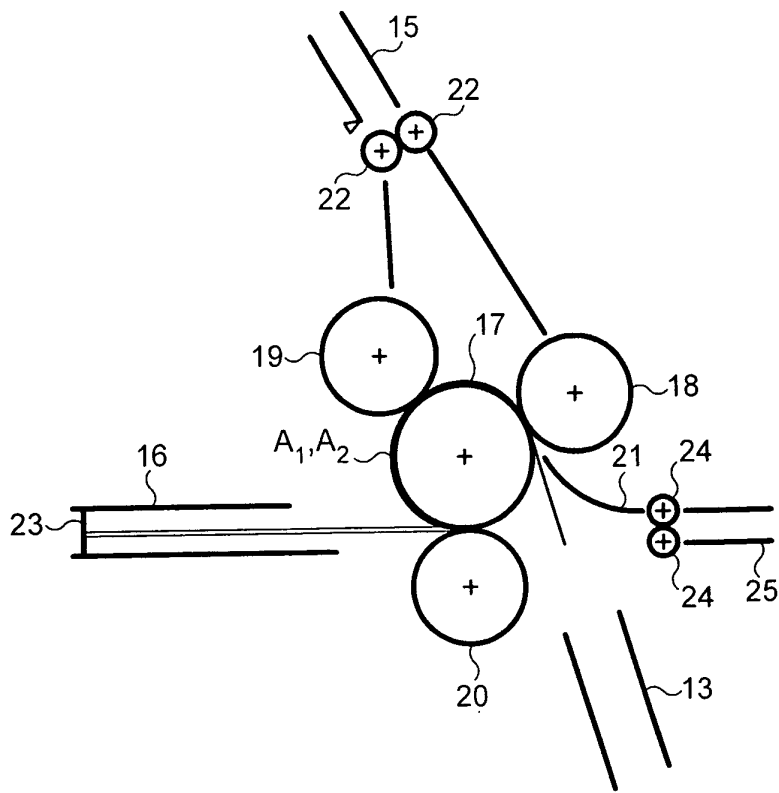

FIG. 2d

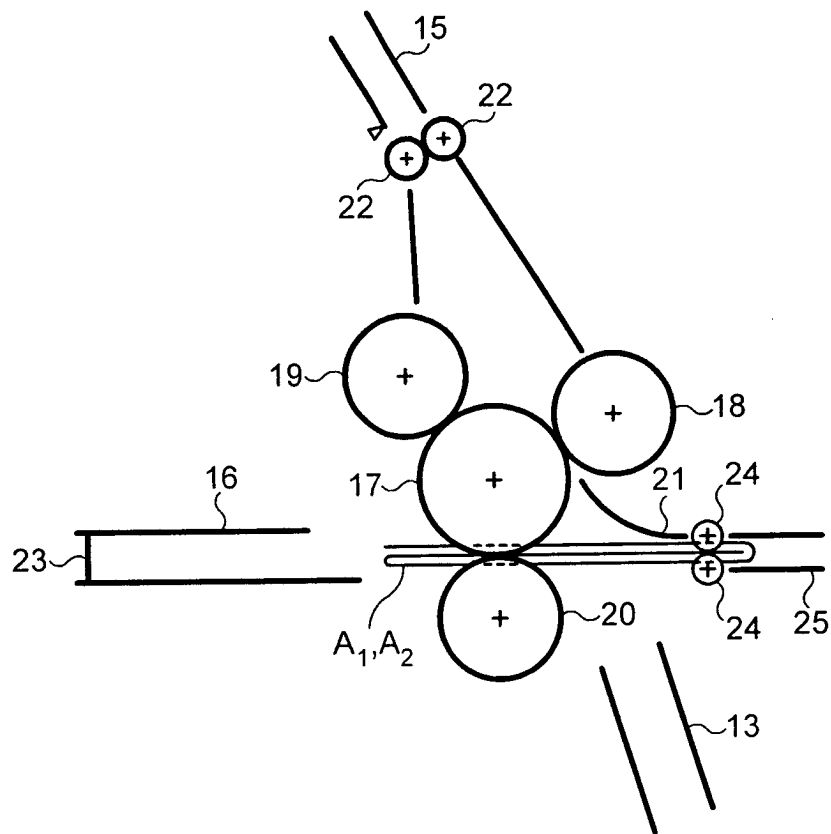

FIG. 2e

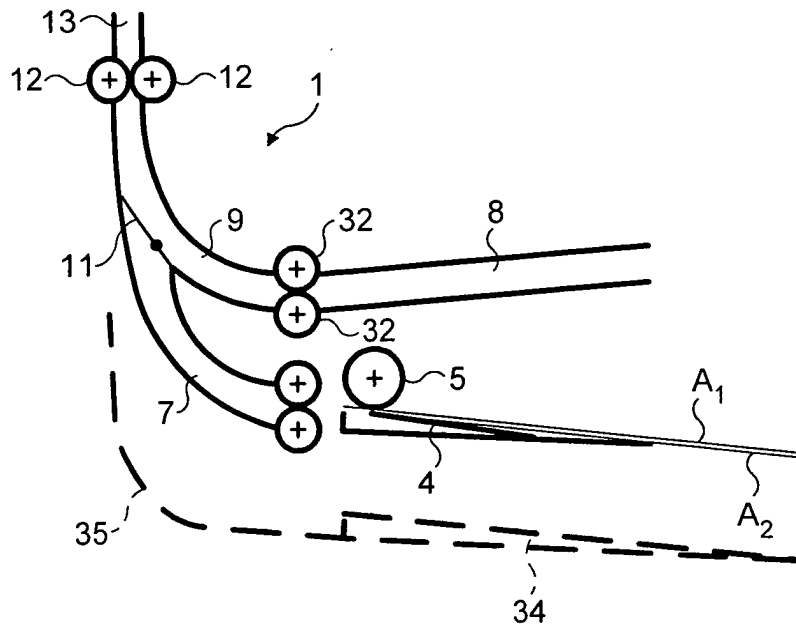

FIG. 3a

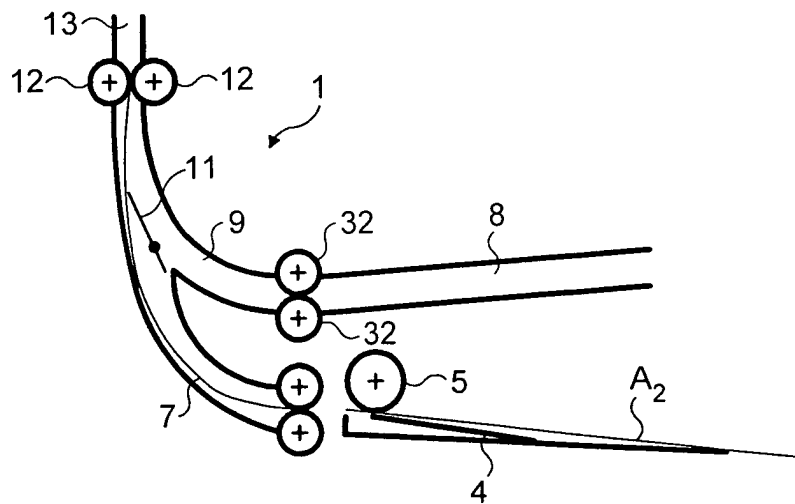

FIG. 3b

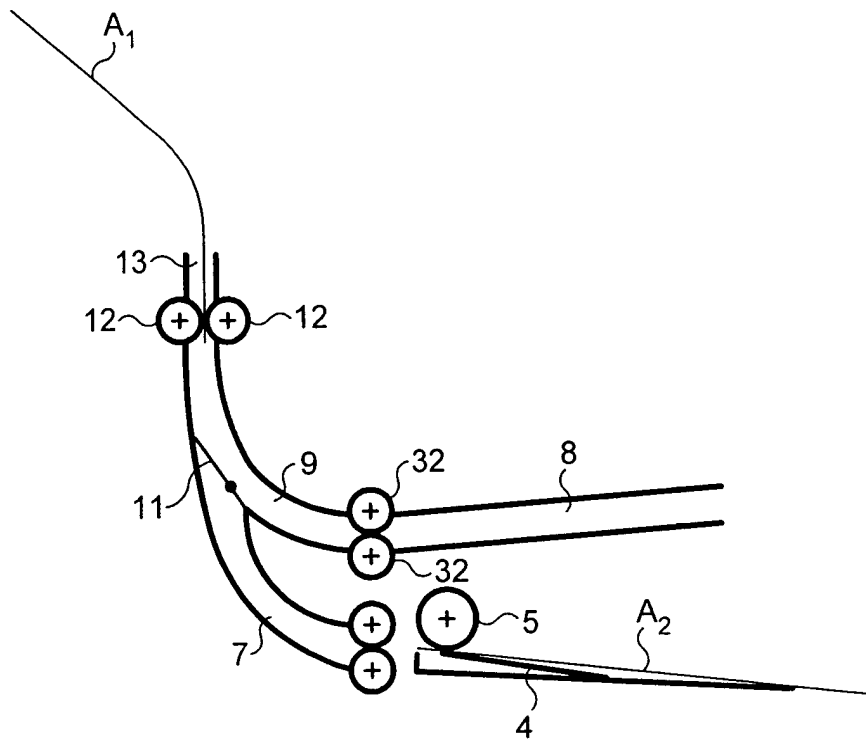

FIG. 3c

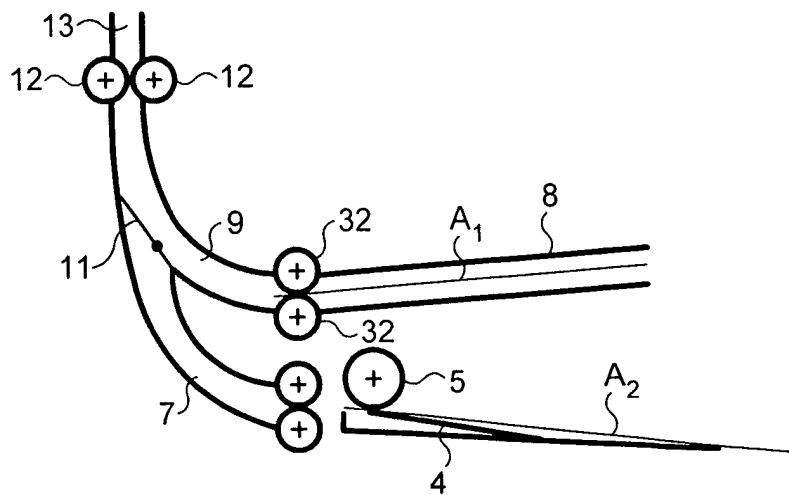

FIG. 3d

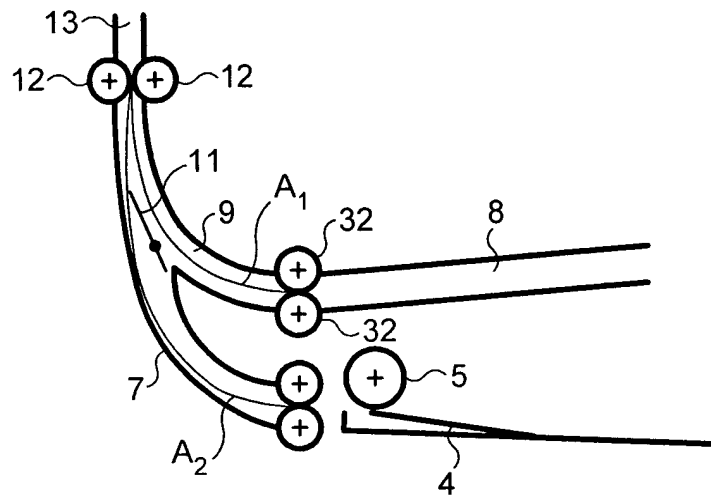

FIG. 3e

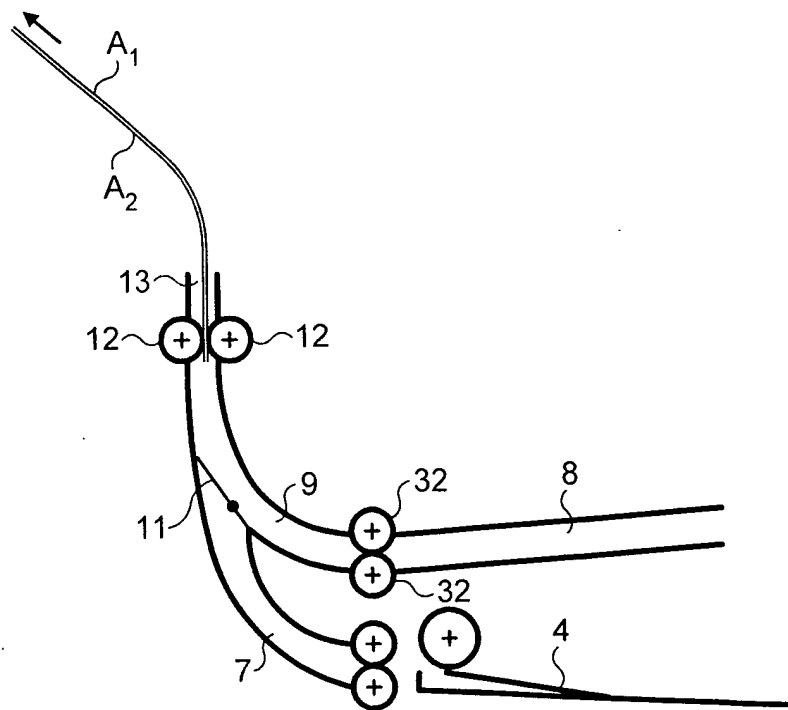

FIG. 3f

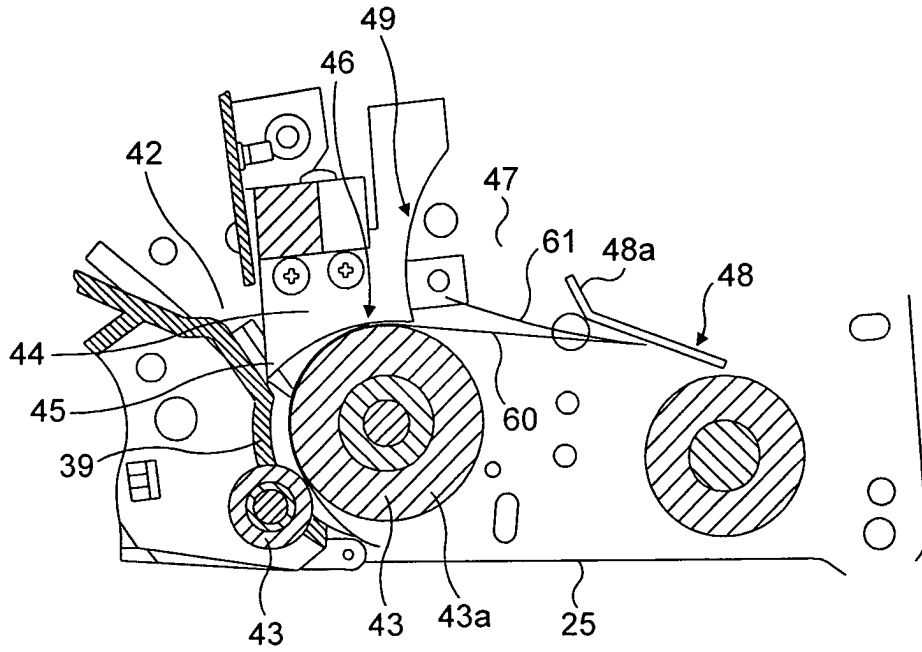

FIG. 4a

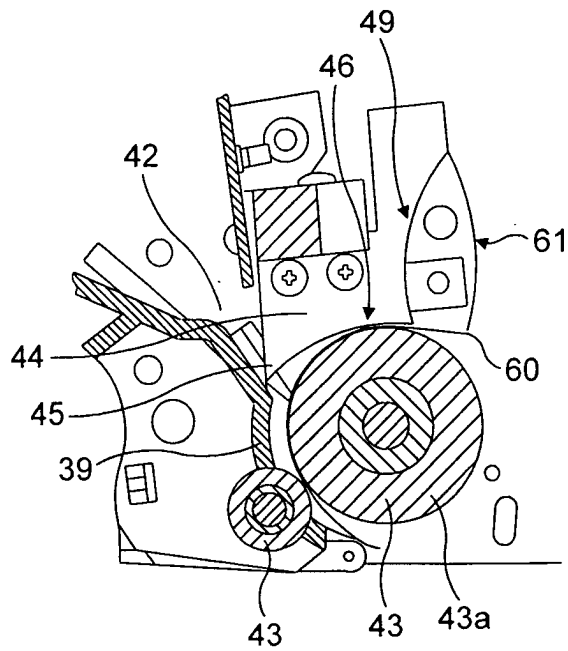

FIG. 4b

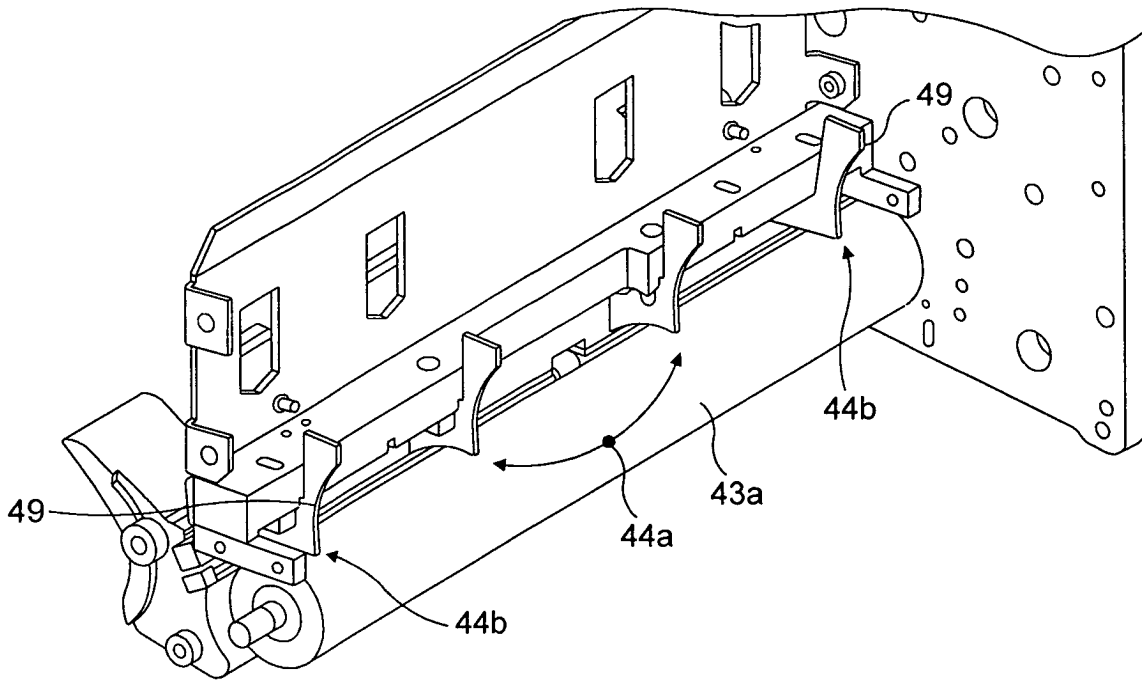

FIG. 5a

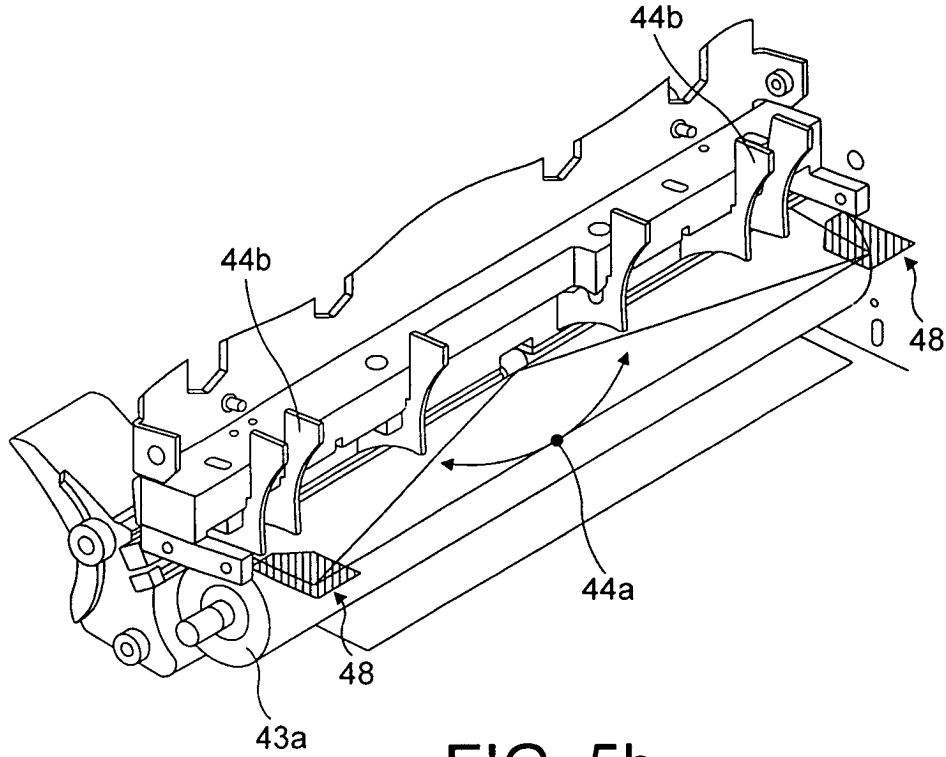

FIG. 5b

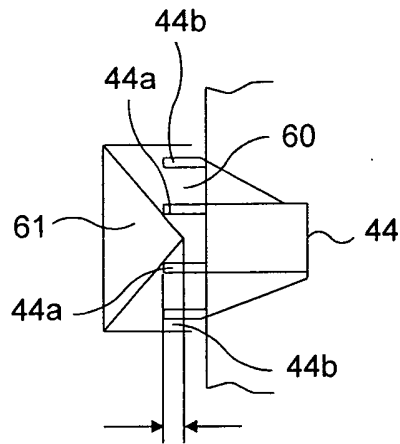

FIG. 6

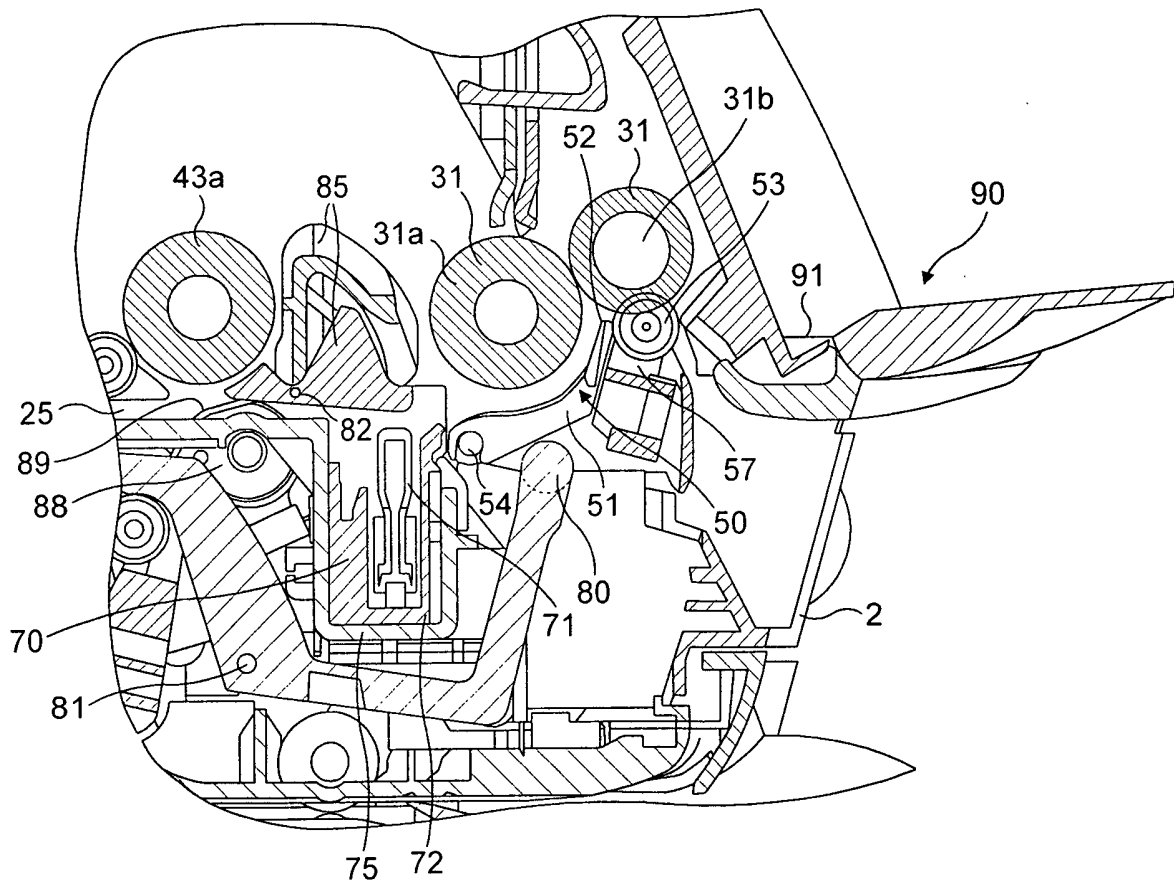

FIG. 7

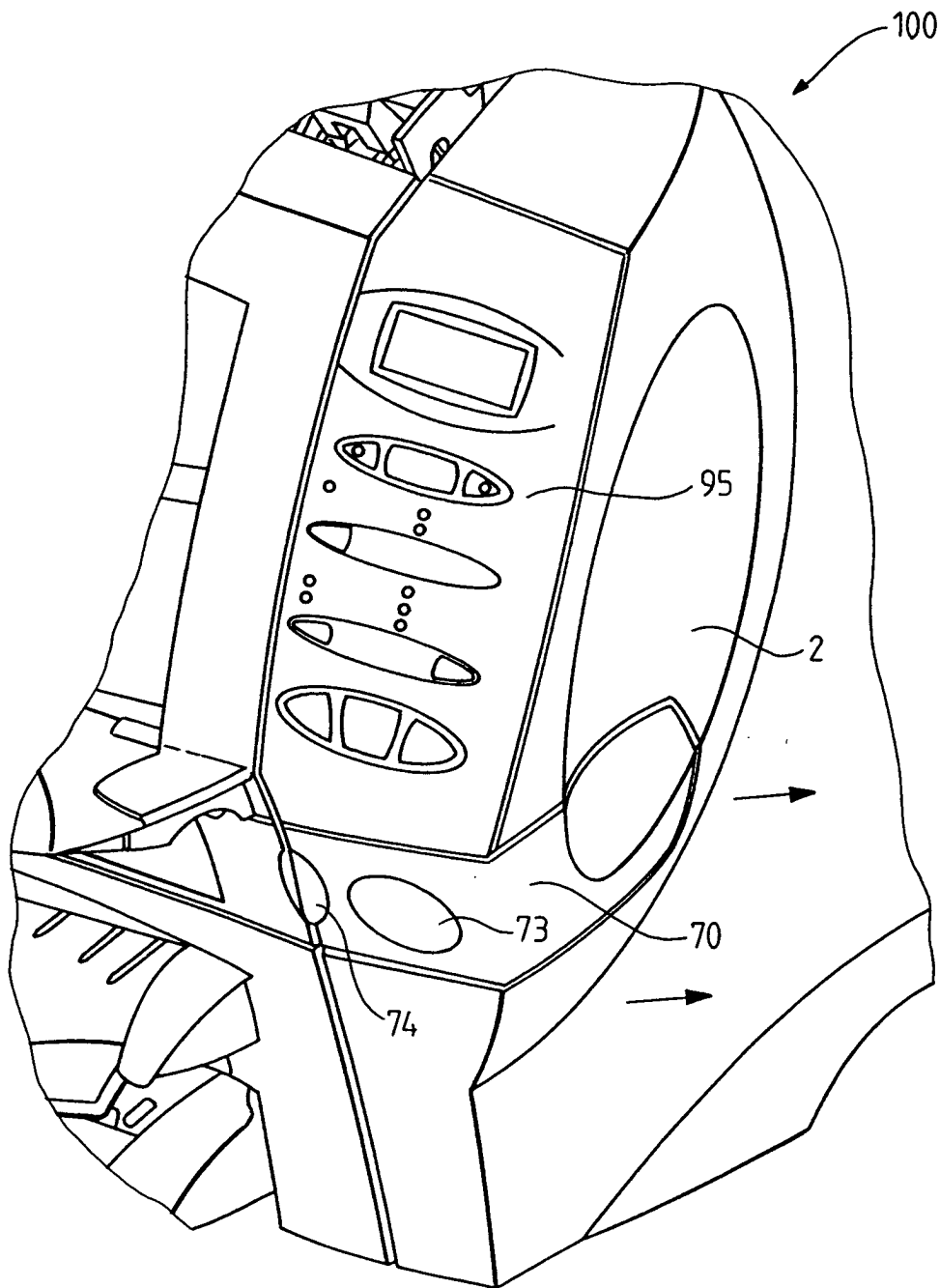

FIG. 8

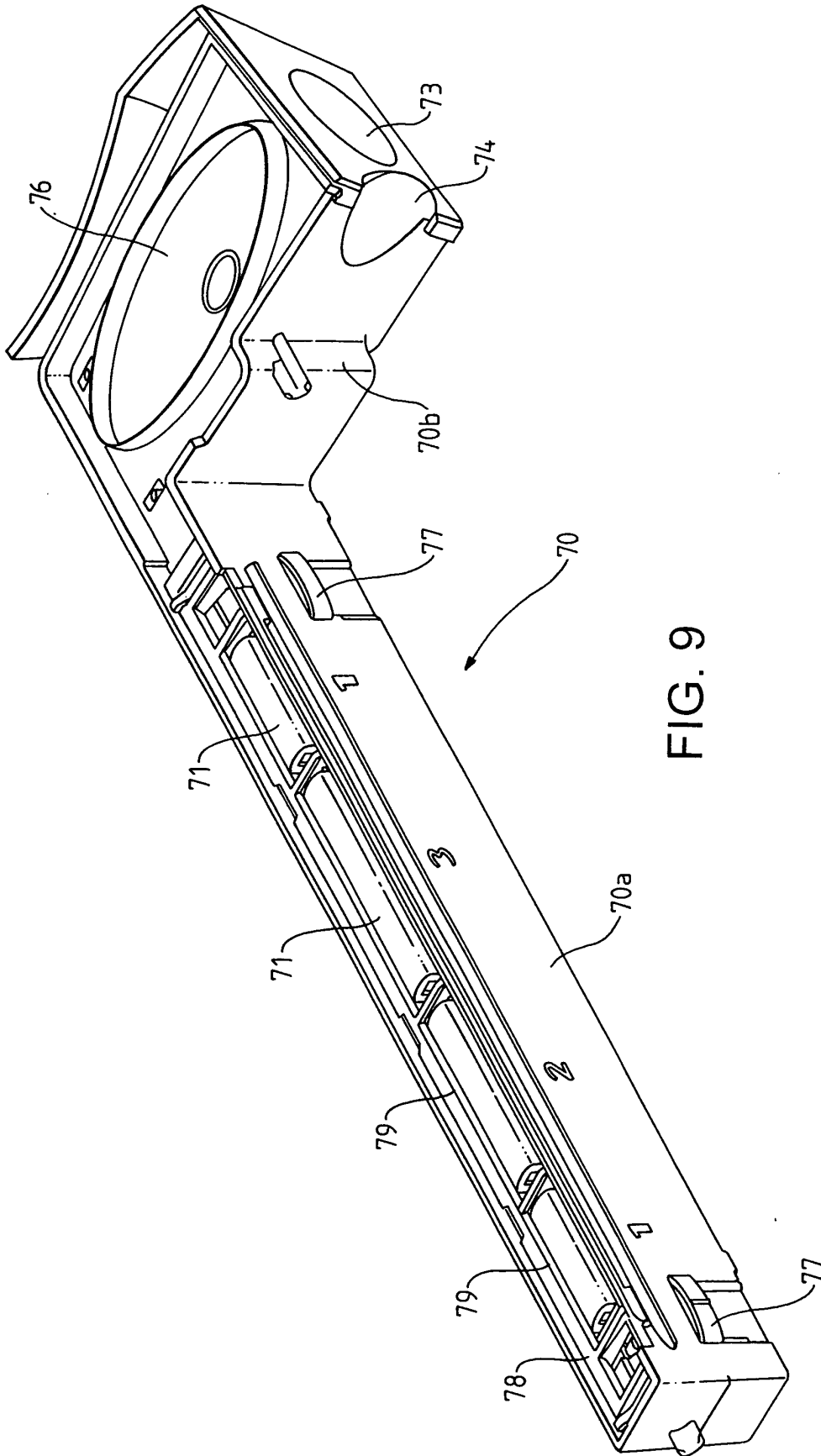

FIG. 9

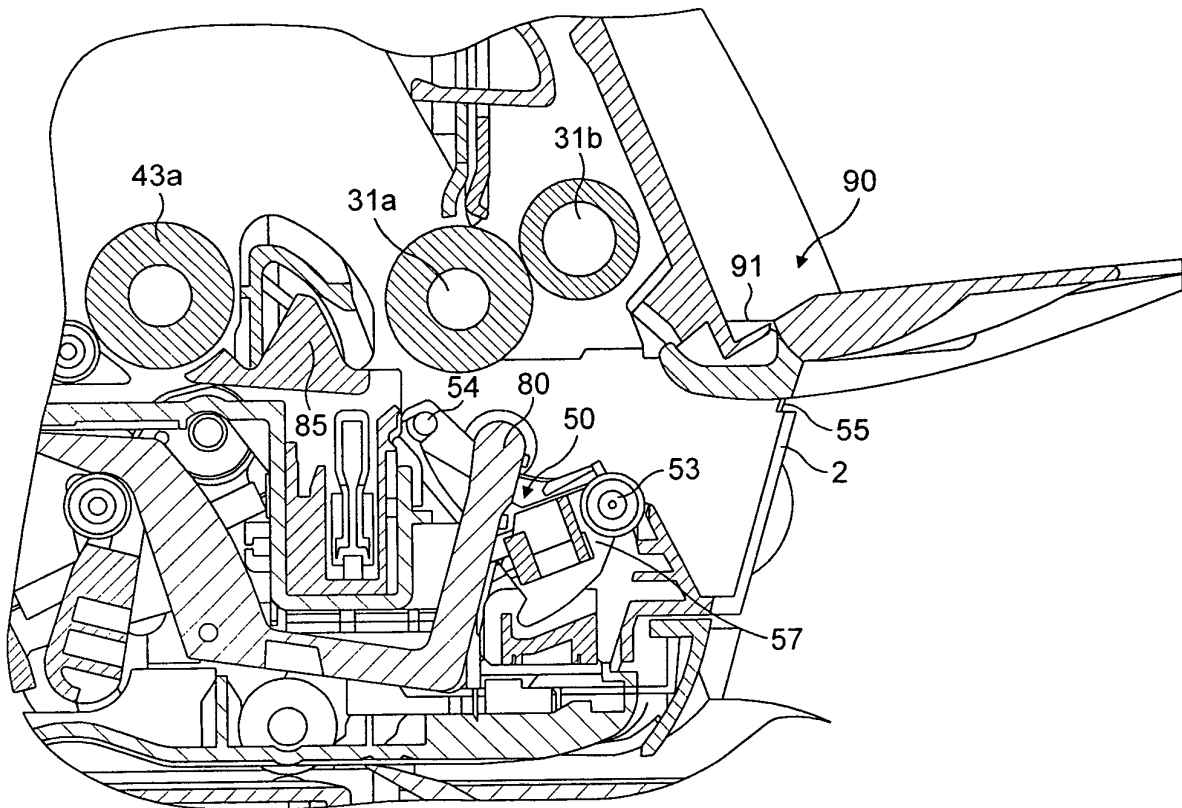

FIG. 10

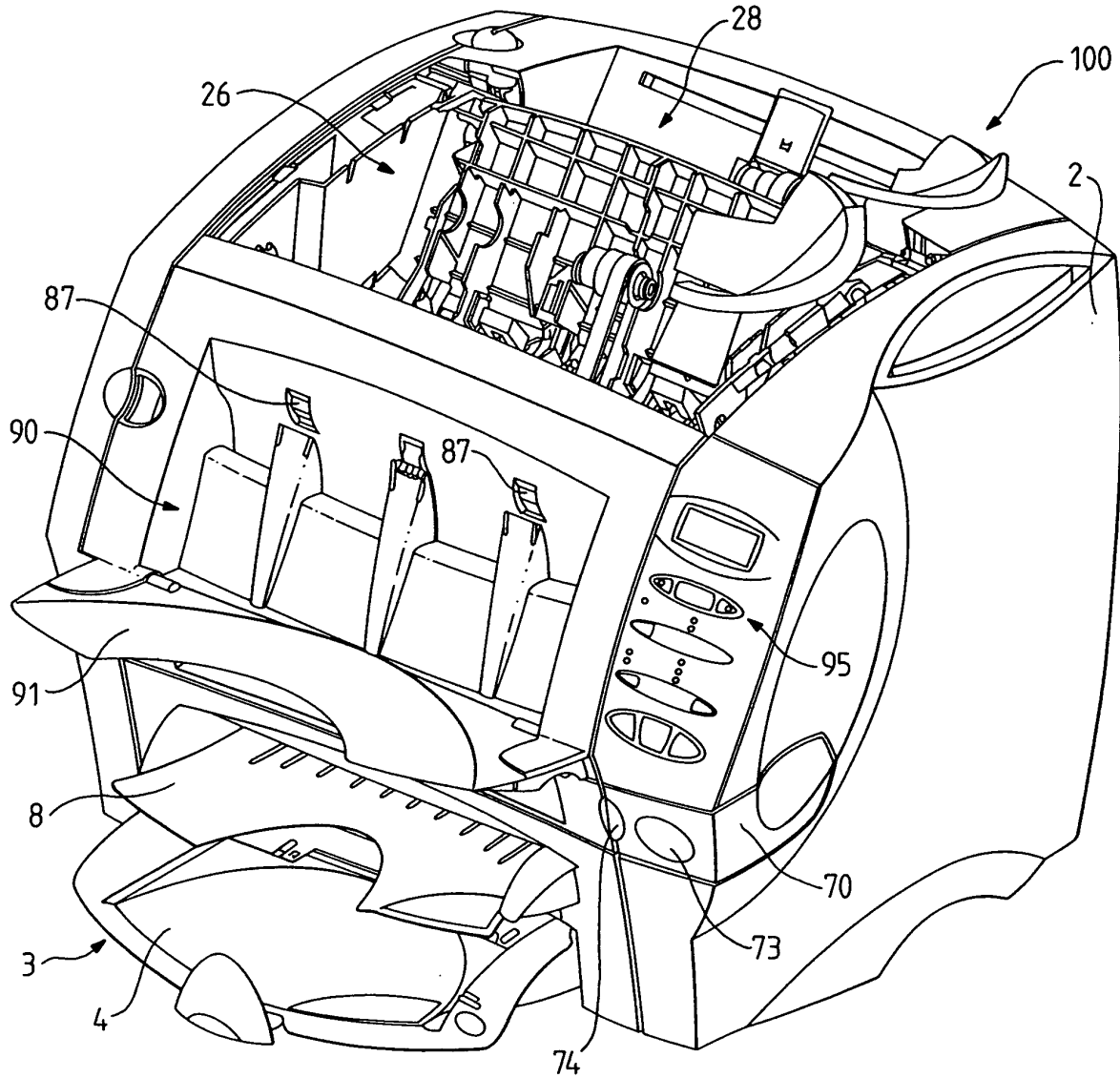

FIG. 11

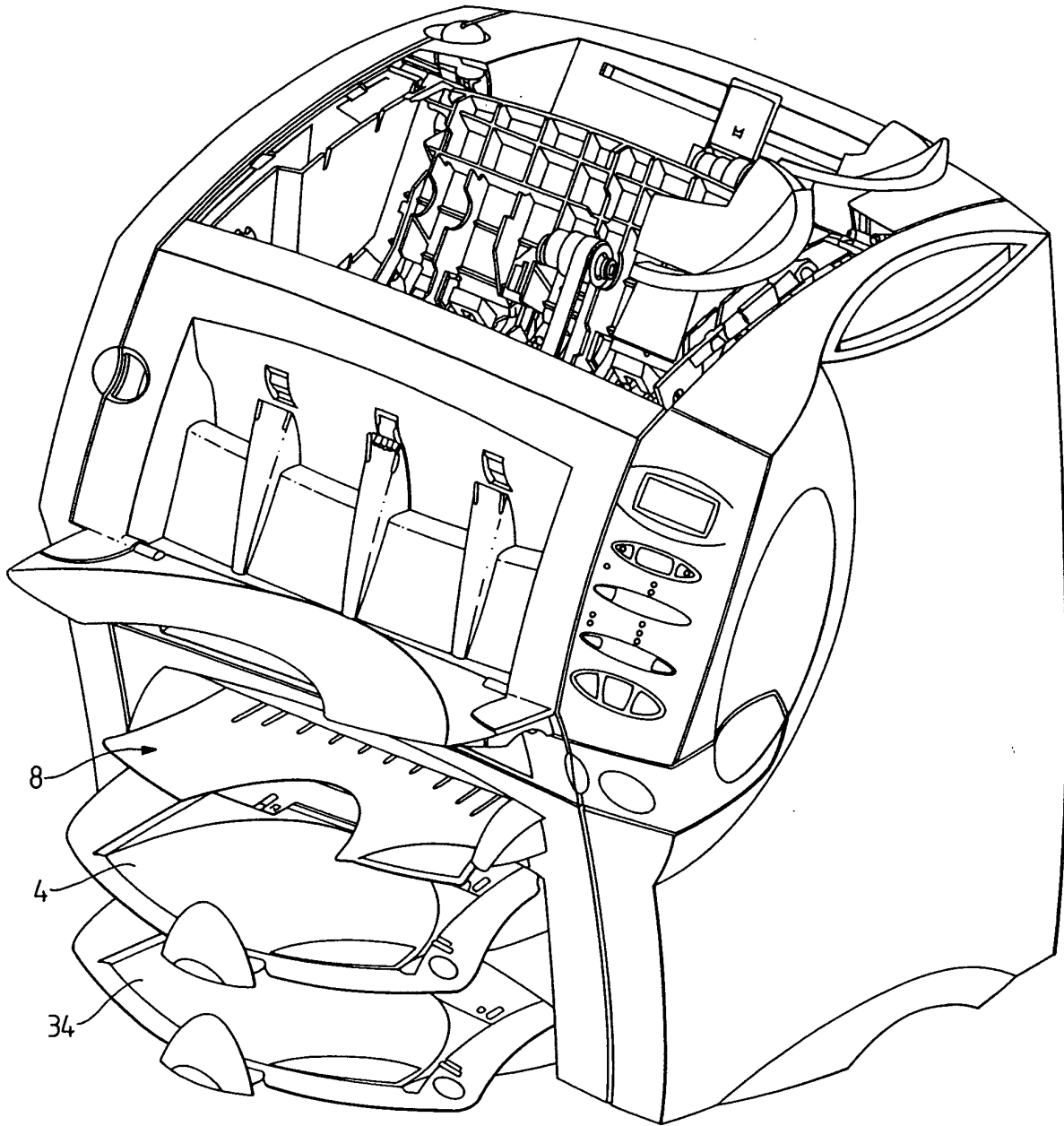

FIG. 11a

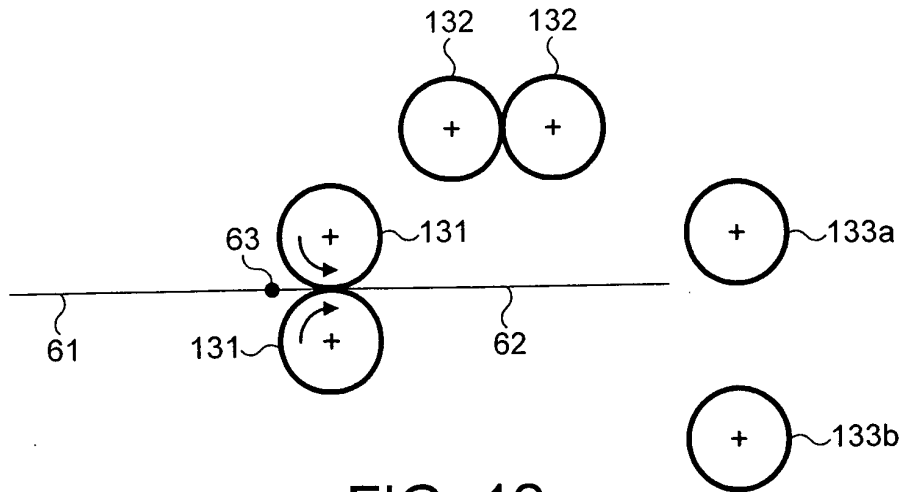

FIG. 12a

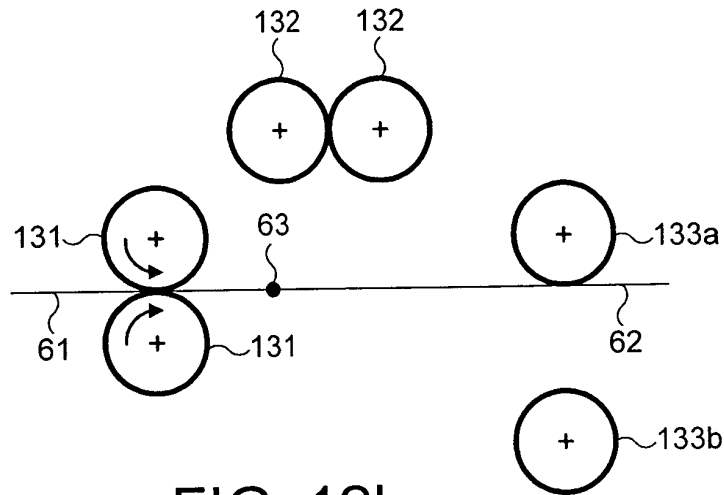

FIG. 12b

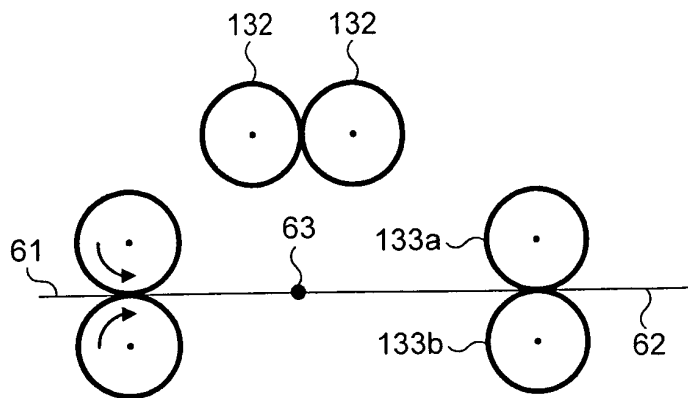
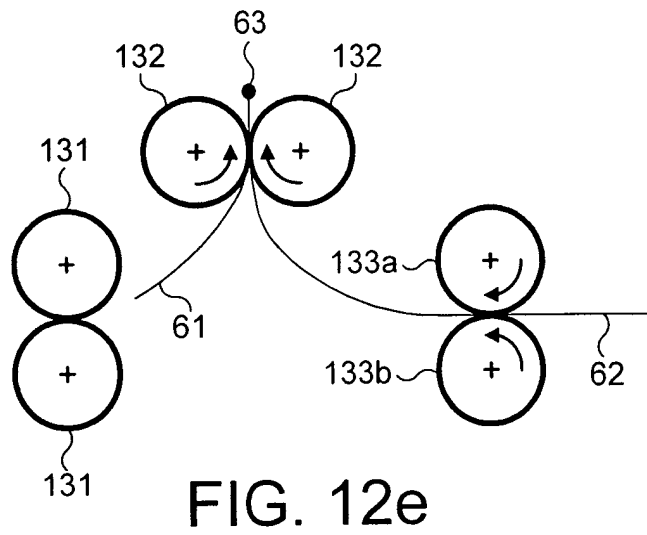
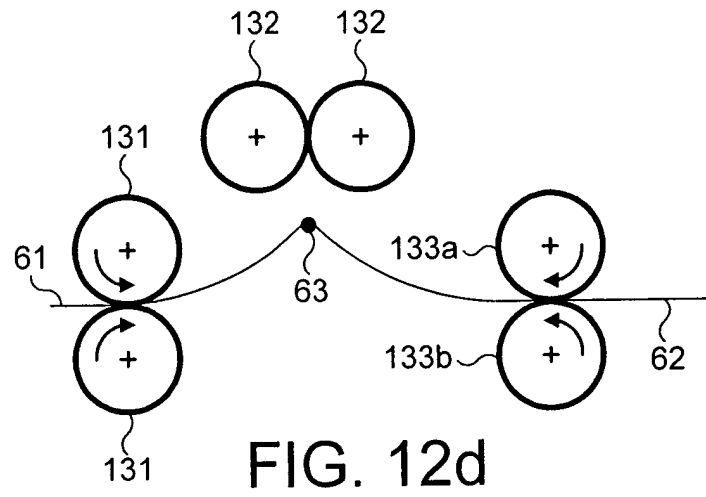

FIG. 12c



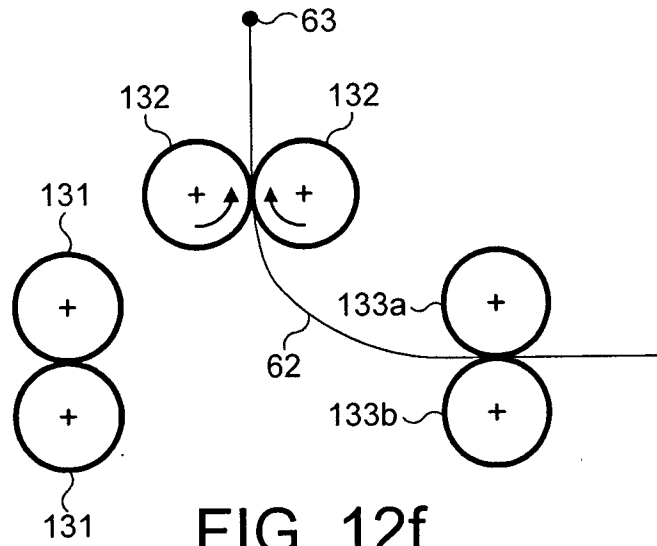

FIG. 12f

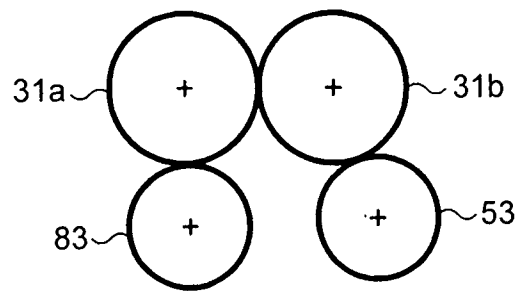

FIG. 12g

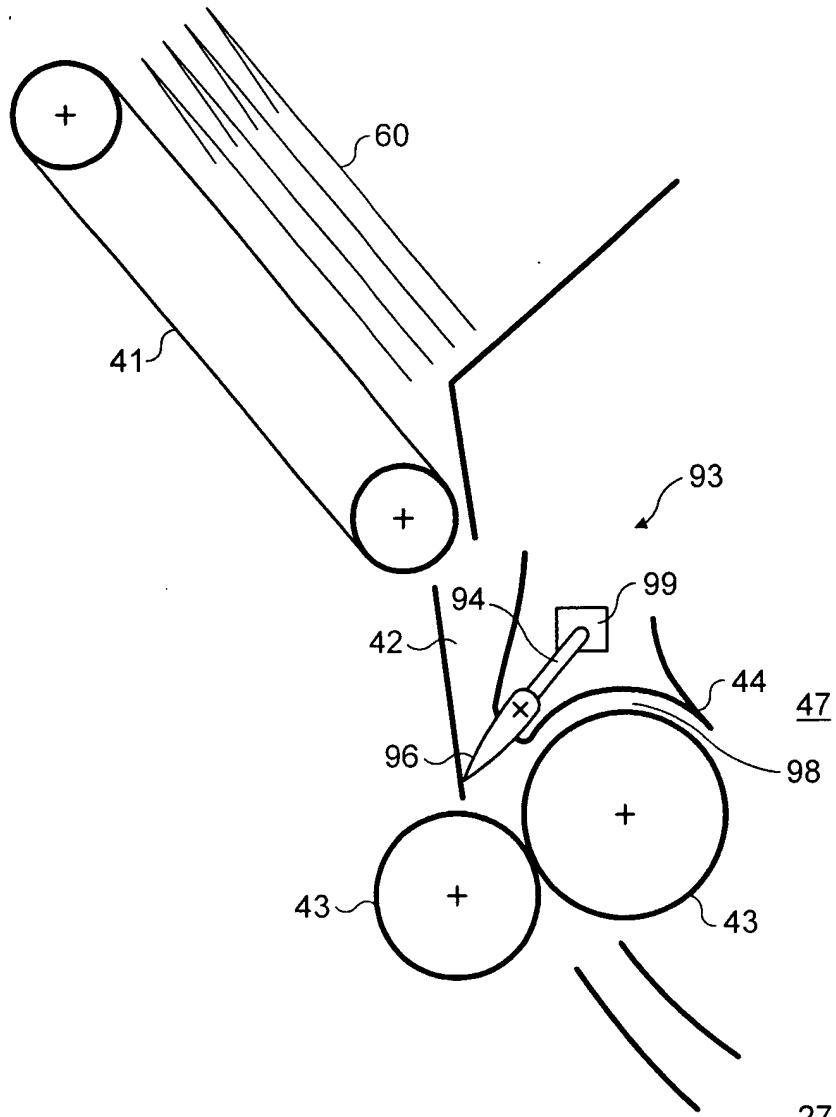

FIG. 13

27

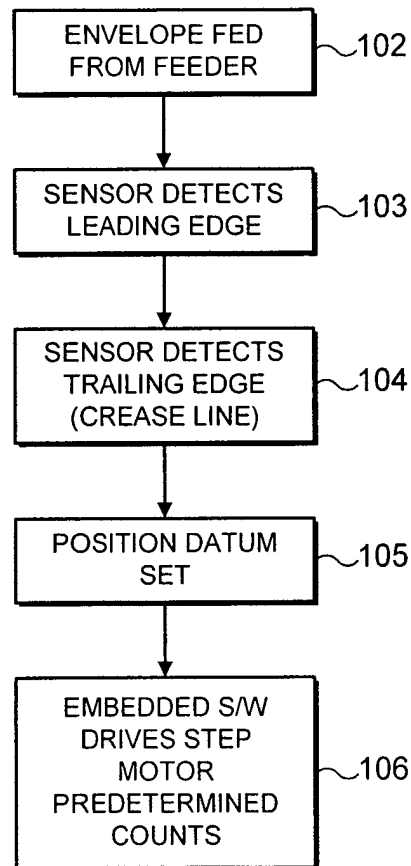

FIG. 14

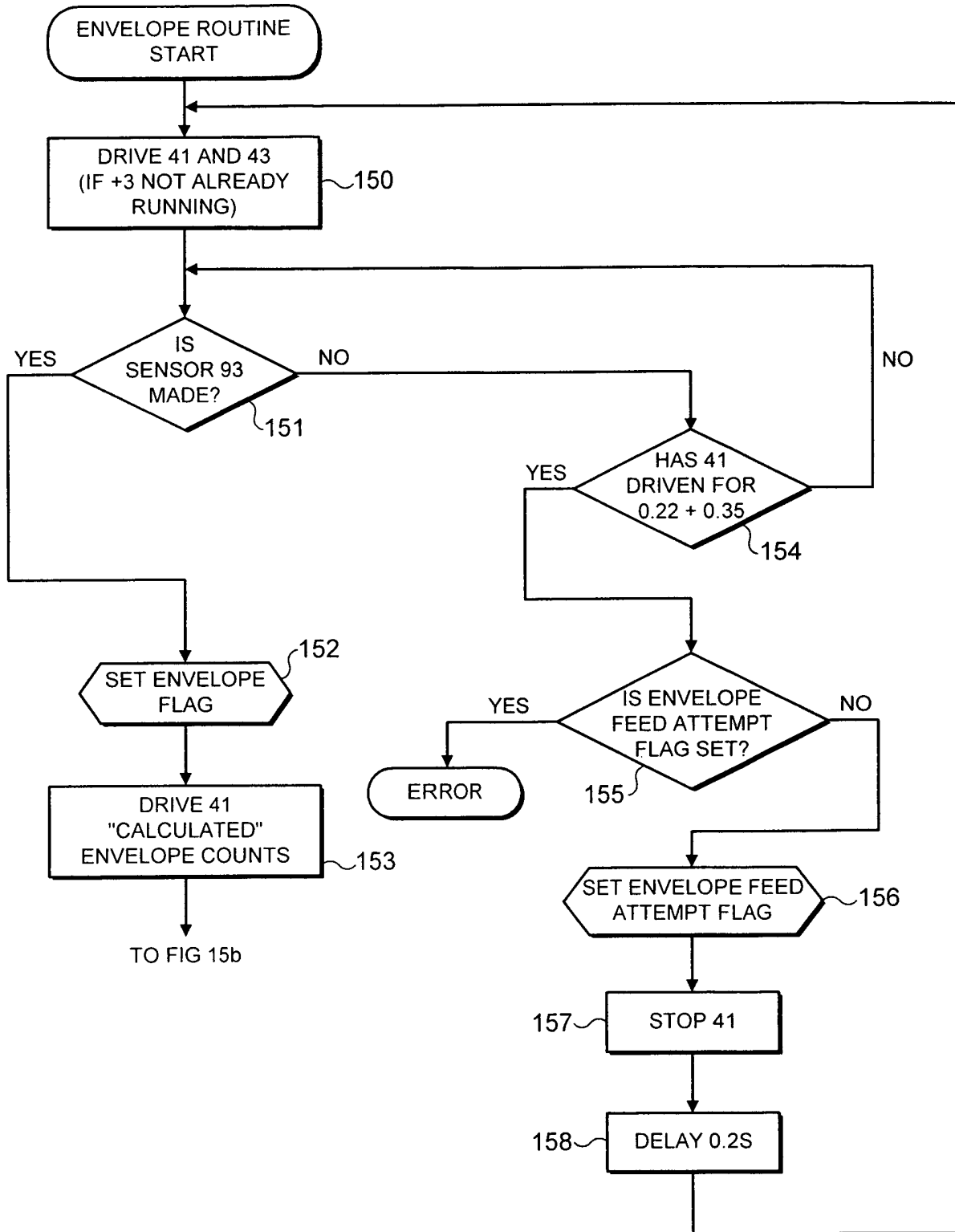

FIG. 15a

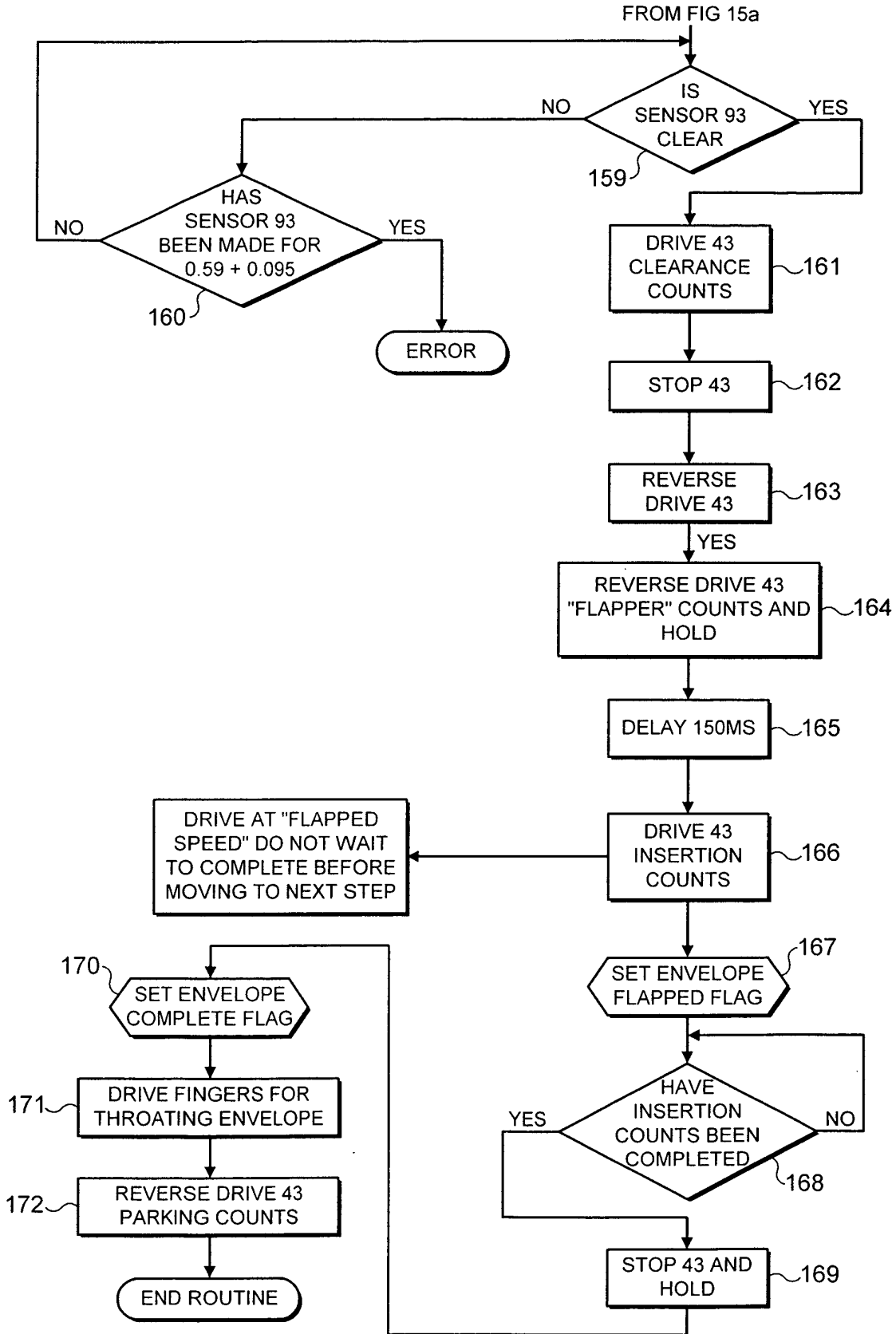

FIG. 15b