

⑫

EUROPEAN PATENT SPECIFICATION

④⑤ Date of publication of patent specification: **14.08.85**

⑤① Int. Cl.⁴: **B 01 L 3/00**, B 65 D 51/00,
A 61 J 1/00

②① Application number: **82306556.0**

②② Date of filing: **08.12.82**

⑤④ **Piercable closures for sample bottles.**

③⑧ Priority: **11.12.81 GB 8137467**

④③ Date of publication of application:
22.06.83 Bulletin 83/25

④⑤ Publication of the grant of the patent:
14.08.85 Bulletin 85/33

④④ Designated Contracting States:
AT BE CH DE FR GB IT LI LU NL SE

⑤⑥ References cited:
BE-A- 438 801
CH-A- 147 396
DE-A-2 051 581
FR-A-2 110 778
FR-A-2 349 510
GB-A- 766 778
GB-A-1 468 801
US-A-2 099 370

⑦③ Proprietor: **Sterilin Limited**
43-45 Broad Street
Teddington Middlesex TW11 8QZ (GB)

⑦② Inventor: **Tait, Richard Bruce**
Ham Glebe Church Road
Ham Richmond Surrey (GB)

⑦④ Representative: **Dodd, David Michael et al**
ROYSTONS 531 Tower Building Water Street
Liverpool L3 1BA (GB)

Note: Within nine months from the publication of the mention of the grant of the European patent, any person may give notice to the European Patent Office of opposition to the European patent granted. Notice of opposition shall be filed in a written reasoned statement. It shall not be deemed to have been filed until the opposition fee has been paid. (Art. 99(1) European patent convention).

Description

The invention relates to piercable closures for containers, particularly sterile or sterilisable containers for samples, usually blood, that may require pathological test and analysis.

It is customary to store such samples in a suitable medium in small containers of moulded plastics materials for extraction using a pipette whose end is used to break or rupture a thin part of the container or of a closure also of moulded plastics material. In general, the use of moulded plastics material has led to the thin part being integral with the container or its closure though British patent No. 1468801 does mention suitable securement of a separately formed thin part to an inset returned neck-like portion of a container.

Recently, there has been a noticeable trend towards preference for the closure itself to be piercable. However, the effort required to pierce such thin or thinned parts of plastics material is high enough to produce adverse reactions from users, and the scope for making such parts even thinner is limited by the danger of porosity or through holes being left with consequent leakage. Due to inherent viscosity of plastics material such as polyethylene, polypropylene and polystyrene, it is, in fact, virtually impossible to obtain consistent flow into mould spaces of less than 0.1 mm. Moreover, tests on polyethylene show that it is still difficult to pierce even at thicknesses much above about 0.02 mm.

It is an object of this invention to provide a closure that is more readily pierced yet safe.

According to one aspect of this invention, there is provided a closure in the form of a dished cap equipped with securement means relative to a sample container, say as a push-fit or via screw-threading of its side walling, and with the dished portion of the cap having an aperture clear through but closed by an added membrane of a non-elastomeric material, usually different from the cap, more readily pierced than any practical integral thinning of the cap material.

We prefer to use a membrane that is between 0.02 mm and 0.50 mm in thickness and of a material and a specific thickness selected to afford practical combination of piercability, robustness and resistance to moisture and water vapour penetration or transmission. A relatively thick material in the above range usually, of course, has advantages, at least in robustness, compared with very thin and easily pierced membranes even where such are not subject to porosity or being left with holes therethrough, though the use of such membranes in practising this invention is not ruled out entirely.

One suitable membrane material is aluminium foil, which we prefer to mount upon a washer-like base apertured to register with the cap aperture when fitted, and generally to form what we call a "wad".

Another aspect of this invention concerns a wad for insertion as a seal into an apertured cap, the wad including an annular washer-like base

member apertured to register with the cap aperture and having secured thereto an aperture-closing membrane that is readily piercable. Preferably, the whole wad is such as to be clamped between a container mouth edge and the cap itself about the aperture of the latter.

In fact, we prefer that the membrane shall extend sufficiently, preferably fully, across the cap dishing. Then the membrane will either be engaged directly by all of the mouth edge of the container, or subjected to compressive clamping by the latter engaging on the base of the wad, depending on the attitude of the wad in the cap.

Satisfactory results have been obtained using woodpulp board for the base of the wad, particularly in enabling ready adherence relative to paper-backed aluminium foil as the membrane. However, a base of closed cell expanded polythene permits lamination directly thereto of plain aluminium foil by means of a heat sensitive adhesive.

In mentioning specific materials for the membrane, and for any base of a wad, our concern is with certain required features that could well be attainable using other materials. Thus, the membrane should afford a liquid-tight seal and act as a suitable barrier against bacteria and water vapour. It is also desirable that the seal should not be subject to adherence problems when, as is required for blood samples, the container must be opened for addition of blood, usually to a suitable medium already in the container (e.g. sodium citrate), and reclosed/sealed pending subsequent piercing to sample for test purposes, usually in a pipette in a pathology laboratory.

We are aware of alternative suitable base materials such as cork or other synthetic plastics materials including expanded and solid polyethylene or expanded or solid polyvinylchloride, and we expect that alternative suitable membrane materials will include other metal foils, say tin, and various flexible synthetic plastics films, say polyester, polyvinylchloride, polyethylene etc. at least where available as films, whether or not paper backed, in suitably piercable form without previous leakage risk disadvantages.

At least wads hereof can often be interference fits to the caps. However, wherever desired or required such wads, even membranes only, may be fixed into the cap using a suitable cement or adhesive, say of hot melt or impact types.

Mention of hot melt adhesive leads us to another aspect hereof where an apertured cap is sealed simply with readily piercable solidified material, such as hot melt adhesive, in the aperture regardless of specific other leak proof features for the cap.

One embodiment of the invention will now be specifically described with reference to the accompanying drawings in which:

Figure 1 is a plan view of a cap and container; Figure 2 is a section of Figure 1 on the lines A—A; and

Figures 3 and 4 are plan and section respectively, of a wad.

In the drawing a container 10 is shown screw-fitted with a dished cap 12 via internal threading of the side wall 14 of the cap mating at 16 with exterior threading of a neck portion 18 of the container below edge 22 of its mouth.

The dished end portion 26 of the cap 12 has a e.g. centrally located aperture 28 clear through its thickness. Clamped between the interior of cap end 26, all about its aperture 28, and the container mouth edge 22 is a wad 30.

The wad 30 comprises an annular washer-like base member 32, centrally apertured at 34 in register with the cap end aperture 28, and a membrane 36 covering that aperture 34. The membrane 36 comprises aluminium foil affixed to base member 32 either directly by a suitable adhesive as indicated for an expanded polythene base, or via a paper backing (not shown, but often advisable for certain wad materials, such as woodpulp board).

It will be noted that the base member 32 is engaged all round by the container mouth edge 22 for desired sealing, in fact abuts substantially entirely to the periphery of the inner surface of the cap end portion 26. With the wad base construction and configuration as shown, we find that the wad needs only to be pressed into place, usually as an interference fit (push-fit), though it could be adheringly secured by a suitable adhesive or cement if preferred or required. Also, the membrane 36 is shown extending entirely across the base member 32, including its aperture, and is subjected to edge compression through the base by action of the container mouth edge 22 to reduce risk of delimitation. It is feasible to use the wad inverted so that the membrane contacts the container mouth edge, so long as a satisfactory seal results, and paper-backing of aluminium or other foil can assist both securement and sealing.

We prefer that the complete wad is made as a unit, i.e. the base member 32 and the membrane 36 affixed securely together. Any suitable adhesive or cement can be used or they may simply be hot-pressed together where waxed backing paper is used for the membrane foil.

The base member 32 of the wad 30 assists in assuring compressive obtainment of a readily broken and reattained liquid seal. Unpreferred, but practical, possibilities arise by way of relying only upon a membrane, perhaps preferably backed, secured directly to the inner surface of the cap, maybe even not fully coextensive therewith, nor sealing to the container mouth edge, or the latter and the cap are mutually formed to seal together without interposition of a barrier foil or film.

Moreover, having described membranes applied to the inner surface of a dished cap, we also now point to the possibility of applying a membrane to the outer surface of the cap and over its aperture.

We have mentioned, heat sensitive, hot melt and impact adhesives for fixing the membrane or membrane-carrying wad to the cap. Adhesives based on synthetic resins are suitable, for

example polyvinyl acetate. Heat sensitive adhesives are preferred for adhering membranes to wad bases. At least hot melt adhesives may even allow membranes to be dispensed with, relying instead simply on a plug of settable but readily pierced material on the cap aperture.

Lamination of foil to a paper backing if used, is conveniently by way of synthetic latex adhesives applied hot or cold, but normally using heat in the laminating process to accelerate curing.

Claims

1. Sterile or sterilisable sample container (10) having a piercable closure wherein the closure comprises a dished cap (12) equipped with securement means (side wall 14, threading 16) relative to a mouth part of the sample container, the dished end portion (26) of the cap having an aperture (28) clear through its thickness but closed by an added impervious membrane (36) of a non-elastomeric material that is readily pierceable by the end of a pipette for extracting the contents of the container.

2. A sample container according to claim 1, wherein the added membrane (36) has a thickness in the range 0.02 mm to 0.50 mm.

3. A sample container according to claim 1 or claim 2, wherein the added membrane (36) is part of a wad (30) retained within the cap, the wad including an annular washer-like base member (32) apertured (at (34)) to register with the cap aperture (28) and covered by the membrane (36).

4. A sample container according to claim 4, wherein the wad (30) is a push-fit in the cap.

5. A sample container according to claim 3 or claim 4, wherein the pad (30) is sealingly borne upon throughout a peripheral edge portion by the mouth edge (22) of the container.

6. A sample container according to claim 3, 4 or 5, wherein the wad is fitted in the cap with the membrane (36) sandwiched between the cap (12) and the base member (32) of the wad.

7. A sample container according to any one of claims 3 to 6, wherein the membrane (36) is of aluminium foil.

8. A sample container according to any one of claims 3 to 7, wherein the base member (32) is of closed cell expanded polythene.

Patentansprüche

1. Steriler oder sterilisierbarer Probenbehälter mit einer durchstoßbaren Abdeckung, dadurch gekennzeichnet, daß die Abdeckung eine schalenförmige Kappe (12) umfaßt, welche mit einer Sicherungseinrichtung Seitenwand (14), Gewinde (16) in Bezug auf dem Mundabschnitt des Probenbehälters versehen ist, und daß der schalenförmige Endabschnitt (26) der Kappe eine Öffnung (28) aufweist, welche sich über ihre Dicke erstreckt jedoch von einer zusätzlichen undurchlässigen, leicht durchstoßbaren Membrane (36) aus einem nichtelastomeren Material verschlossen ist.

2. Probenbehälter nach Anspruch 1, dadurch gekennzeichnet, daß die zugefügte Membrane (36) eine Dicke in dem Bereich von 0,02 mm bis 0,50 mm aufweist.

3. Probenbehälter nach Anspruch 1 oder 2, dadurch gekennzeichnet, daß die zugefügte Membrane (36) Teil eines Pfropfens (30) ist, welcher innerhalb der Kappe gehalten ist, und daß der Pfropfen ein ringförmiges scheibenähnliches Bodenglied (32) einschließt, das eine Öffnung (34) umfaßt, die von der Membran (36) abgedeckt ist und mit der Kappenöffnung (28) fluchtet.

4. Probenbehälter nach Anspruch 4, dadurch gekennzeichnet, daß der Pfropfen (30) ein Schieb-sitz in der Kappe ist.

5. Probenbehälter nach Anspruch 3 oder 4, dadurch gekennzeichnet, daß der Pfropfen (30) über seinen vollständigen Umfangsrandabschnitt von dem Mundrand (22) des Behälters dichtend ge-tragen ist.

6. Probenbehälter nach Anspruch 3, 4 oder 5, dadurch gekennzeichnet, daß der Pfropfen in der Kappe eingepaßt ist, wobei die Membrane (36) zwischen der Kappe (12) und dem Bodenglied (32) des Pfropfens eingelegt ist.

7. Probenbehälter nach einem der Ansprüche 3 bis 6, dadurch gekennzeichnet, daß die Mem-brane (36) aus einer Aluminiumfolie besteht.

8. Probenbehälter nach einem der Ansprüche 3 bis 7, dadurch gekennzeichnet, daß das Boden-glied (32) aus geschlossenzelligem expandiertem Polythene besteht.

Revendications

1. Conteneur stérile ou stérilisable (10) pré-sentant un fermeture perçable, caractérisé en ce que la fermeture comprend un couvercle (12) bombé équipé de moyens de verrouillage (paroi

latérale (14), filetage (16)) relativement à une partie de l'embouchure du conteneur, l'extrémité bombée (26) du couvercle présentant une ouver-ture (28) libre, pratiquée à travers l'épaisseur dudit couvercle mais obturée par un membrane étanche rajoutée, facilement perçable (36), en un matériau non élastomère.

2. Un conteneur selon la revendication 1, carac-térisé en ce que la membrane (36) rajoutée a une épaisseur de l'ordre de 0,02 à 0,05 mm.

3. Un conteneur selon l'une des revendications 1 ou 2, caractérisé en ce que la membrane rajoutée (36) est partie d'un bouchon (30) retenu par le couvercle, ledit bouchon comprenant un élément de base annulaire en forme de rondelle (32) avec une ouverture (34) adaptée à l'ouverture (28) du couvercle, recouverte par la membrane (36).

4. Un conteneur selon la revendication 3, carac-térisé en ce que le bouchon (30) est ajustable par poussée dans le couvercle.

5. Un conteneur selon l'une des revendications 3 ou 4, caractérisé en ce que le bouchon (30) est maintenu de façon étanche par son contour périphérique par le bord de l'embouchure (22) du conteneur.

6. Un conteneur selon l'une des revendications 3, 4 ou 5, caractérisé en ce que le bouchon est ajusté dans le couvercle avec la membrane (36) prise en sandwich entre le couvercle (12) et l'élément (32) du bouchon.

7. Un conteneur selon l'une quelconque des revendications 3 à 6, caractérisé en ce que la membrane (36) est une feuille d'aluminium.

8. Un conteneur selon l'une quelconque des revendications 3 à 7, caractérisé en ce que l'élé-ment de base (32) est en polyéthylène expansé à cellules fermées.

5

10

15

20

25

30

35

40

45

50

55

60

65

4

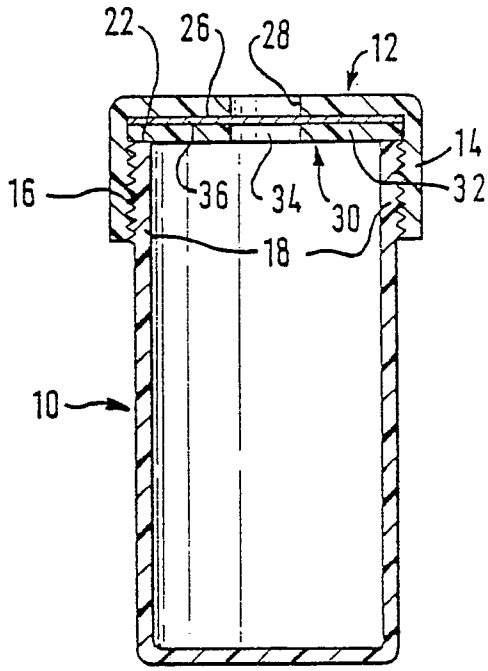

FIG. 2.

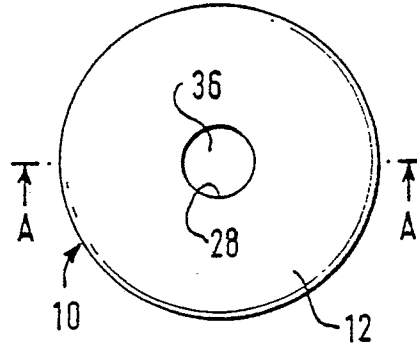

FIG. 1.

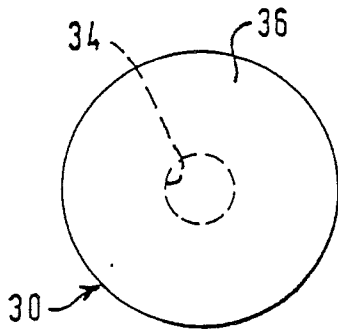

FIG. 3.

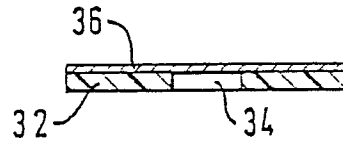

FIG. 4.