

Dec. 13, 1938.

L. L. STRATTON

2,139,779

REFRIGERATOR

Filed April 22, 1936

4 Sheets-Sheet 1

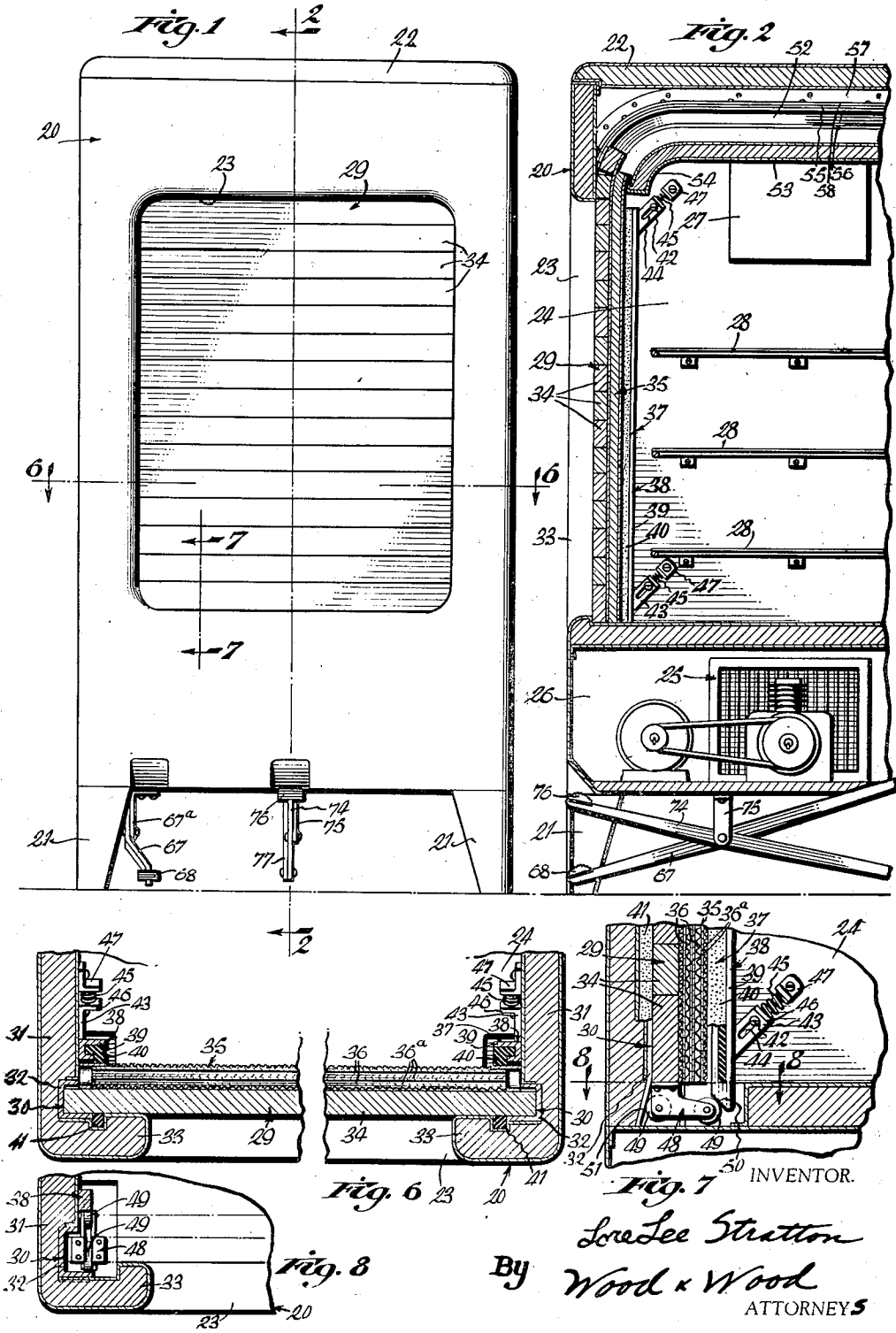

INVENTOR.  
*Low Lee Stratton*  
By *Wood & Wood*  
ATTORNEYS

Dec. 13, 1938.

L. L. STRATTON

2,139,779

REFRIGERATOR

Filed April 22, 1936

4 Sheets-Sheet 2

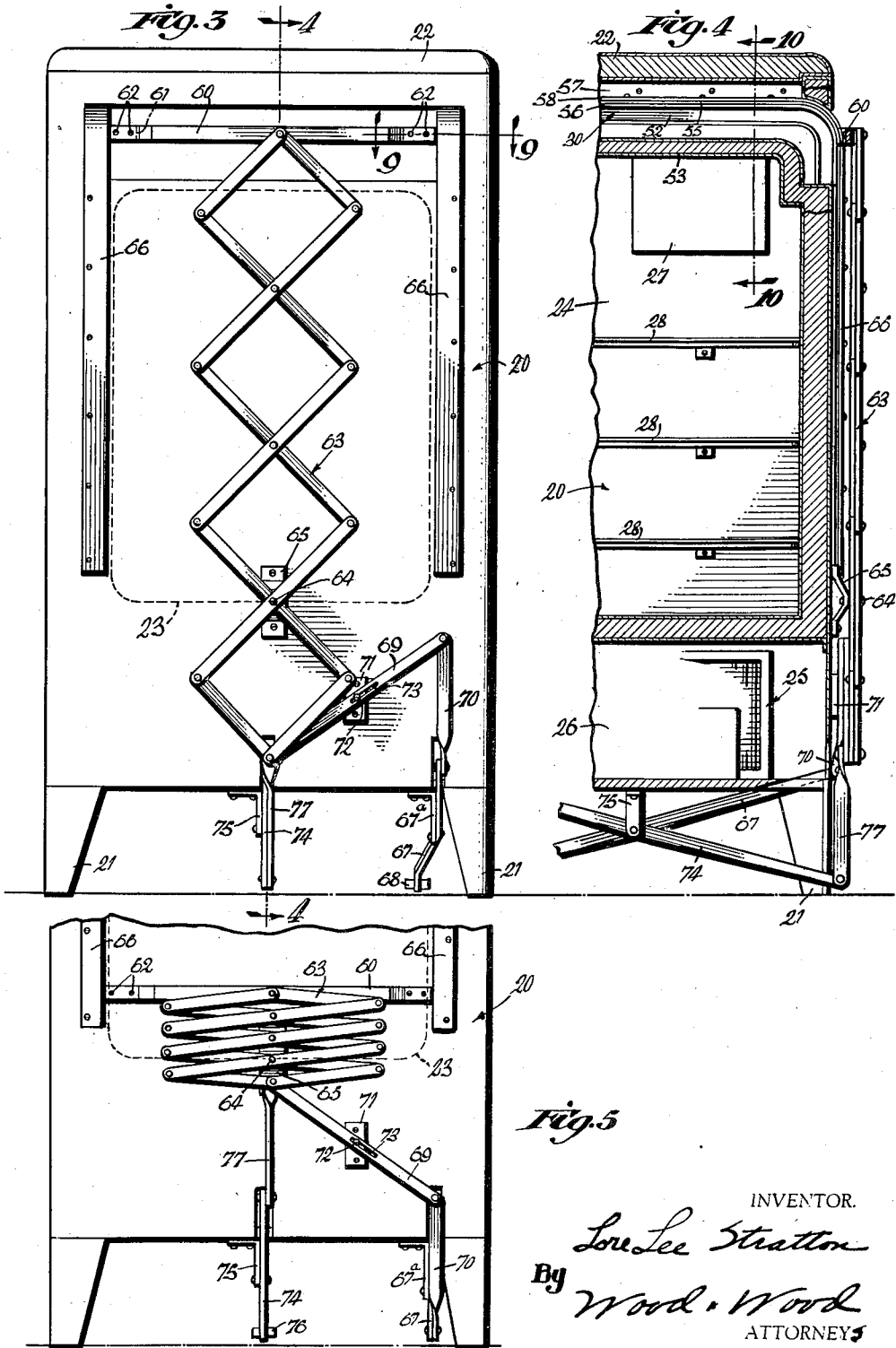

Fig. 5

INVENTOR.

*Lou Lee Stratton*

By *Wood & Wood*  
ATTORNEYS

Dec. 13, 1938.

L. L. STRATTON

2,139,779

REFRIGERATOR

Filed April 22, 1936

4 Sheets-Sheet 3

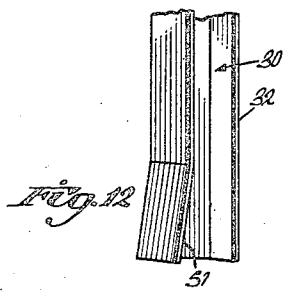
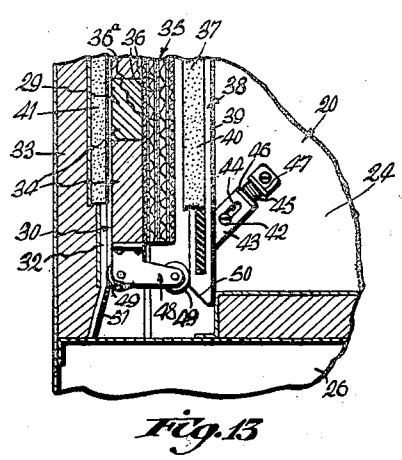
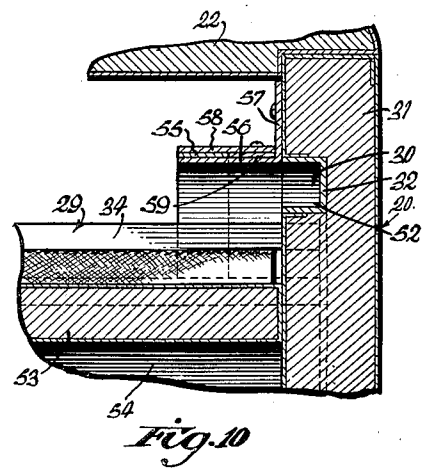
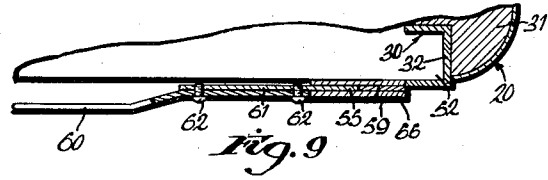
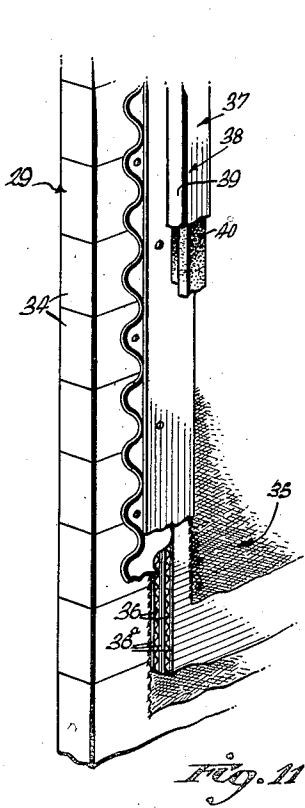

INVENTOR.  
*Low Lee Stratton*  
BY  
*Wood & Wood*  
ATTORNEYS

Dec. 13, 1938.

L. L. STRATTON

2,139,779

REFRIGERATOR

Filed April 22, 1936

4 Sheets-Sheet 4

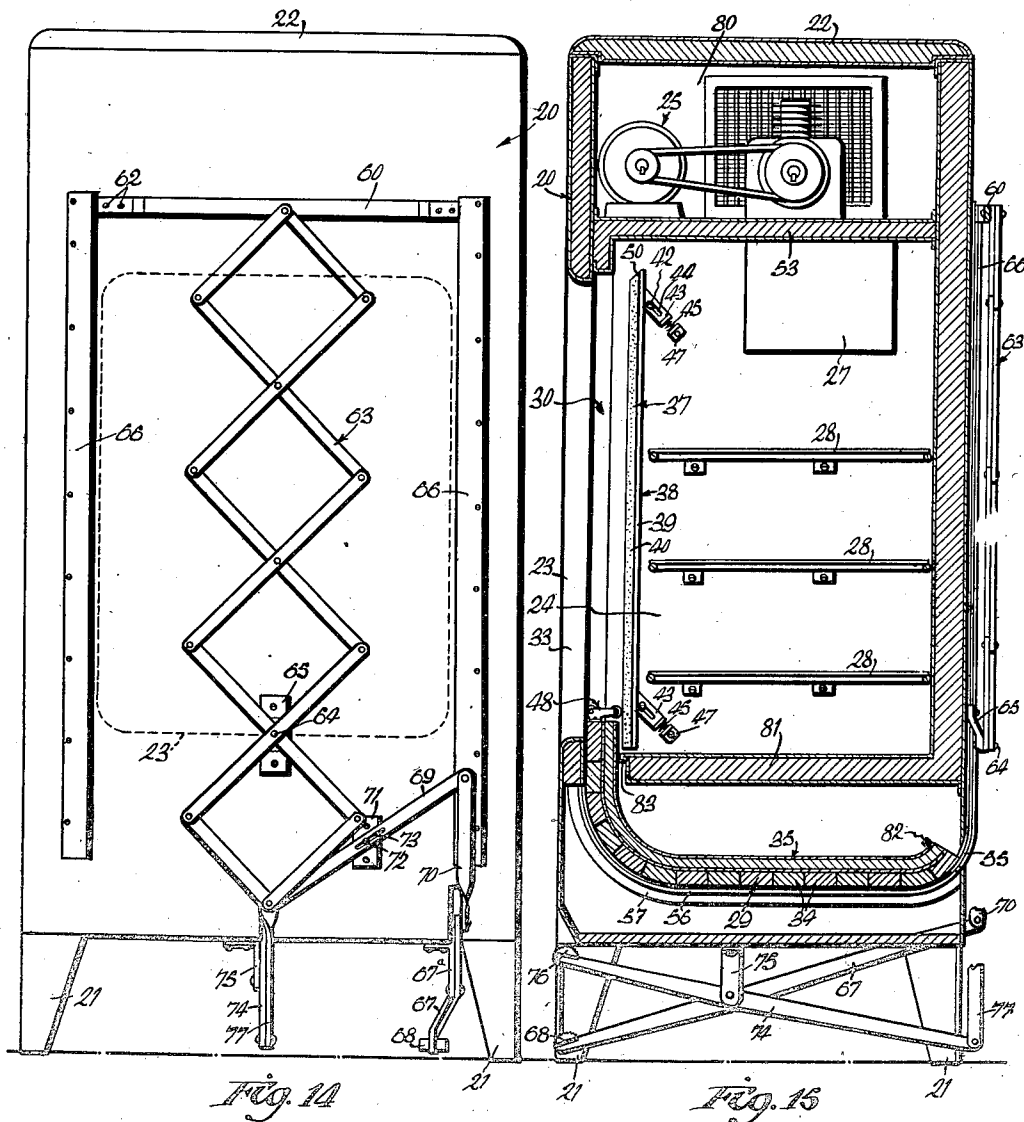

INVENTOR.  
*Lou Lee Stratton*  
BY  
*Wood & Wood*  
ATTORNEYS

# UNITED STATES PATENT OFFICE

2,139,779

## REFRIGERATOR

Lore Lee Stratton, Cincinnati, Ohio

Application April 22, 1936, Serial No. 75,821

6 Claims. (Cl. 312-192)

This invention relates to refrigerators and is particularly directed to an improved door arrangement and structure, and operating means therefor.

5 The hinged door now in use on refrigerators presents many disadvantages. In the first place, when access to any portion of the refrigerator is desired, the door must be opened. Since the door covers the entire opening and one can only  
10 operate it by swinging it on its hinges, almost the entire interior of the refrigerator is opened to the atmosphere, and the cold air quickly escapes. It is also a current fault with this type of door that it must be manually operated. This  
15 is a disadvantage, particularly when the housewife is carrying a number of articles to the refrigerator and has her hands full. A still further disadvantage exists in the fact that the hinges are ordinarily on the outside of the re-  
20 frigerator, and, despite careful designing, present projections which are unsightly since they tend to destroy the straight lines of the modern refrigerator. A further disadvantage resides in the fact that a clear space is required not only  
25 in front of the refrigerator but to one or the other side as well, necessitating right and left hand doors. This increases production costs and requires increased storage space.

It is an object of the present invention to  
30 provide an improved door and door arrangement for a refrigerator, as well as an improved operating mechanism for the door, whereby all of the above mentioned disadvantages are elimi-  
35 nated. The improved door can be opened any amount. It need be opened only for the purpose of providing access to a particular portion or region of the storage compartment. Moreover, the door is operated by foot pressure and  
40 incorporates a leverage and balance arrangement for easy and rapid operation. A still further feature resides in the elimination of hinges or obtrusive projections, the door being con-  
45 tained within the refrigerator and the opening having the appearance of a recess when the door is closed. Moreover, there is no longer any necessity for right and left hand doors. Clear-  
50 ance space need only exist directly in front of the door and the refrigerator is standard for all installations.

Other objects relate to the fabrication of the refrigerator for the purpose of including the door and guiding it, to the mounting and arrange-  
55 ment of the leverage mechanism for operating the door, and to means active on the door for

positively sealing the opening when the door is closed.

Other objects and further advantages will be more fully apparent from a description of the accompanying drawings, in which:

5 Figure 1 is a front view of a refrigerator, showing the improvements incorporated therein.

Figure 2 is a sectional view taken on line 2-2, Fig. 1, showing the interior cabinet construction and door mounting with the door in closed  
10 position.

Figure 3 is a rear view of the refrigerator, showing the mechanism for operating the door.

Figure 4 is a sectional view taken on line 4-4, Figure 3, detailing the interior construction to-  
15 ward the rear of the refrigerator.

Figure 5 is a fragmentary rear view of a refrigerator taken similar to Figure 3 but showing the door operating mechanism in position when  
20 the door is open.

Figure 6 is a fragmentary sectional view taken on line 6-6, Figure 1, illustrating the details of the door and its guide arrangement in the refrigerator structure.

Figure 7 is a fragmentary sectional view taken  
25 on line 7-7, Figure 1, illustrating in detail the structure at the base of the door.

Figure 8 is a sectional view taken on line 8-8, Figure 7, further detailing the structure of that  
view.

Figure 9 is a sectional view taken on line 9-9, Figure 3, illustrating one of the guides for the door operating mechanism.

Figure 10 is a sectional view taken on line  
35 10-10, Figure 4, illustrating one side of the guides for the door and door operating mechanism respectively.

Figure 11 is a fragmentary perspective view with certain of the parts broken away, illustrat-  
40 ing the structure of the door.

Figure 12 is a fragmentary perspective view of the lower end of the door guide.

Figure 13 is a view taken similar to Figure 7, but illustrating the door slightly raised.

Figure 14 is a rear view of a refrigerator incor-  
porating a slightly modified arrangement of the door.

Figure 15 is a sectional view taken on line  
50 15-15, Figure 14, showing the interior construction of a refrigerator incorporating the modified door arrangement.

Referring to the drawings, the refrigerator casing structure is generally indicated at 20 and is formed of metal filled with wood fibre (or any other suitable insulation). It is lined, inside

and out, with metal. Legs 21 and a top 22 are incorporated. An opening 23 is provided for access to the storage compartment 24. In the main form the refrigeration unit 25 is incorporated in a compartment 26 in the base of the cabinet. The freezing compartment is generally indicated at 27 and the food racks at 28.

The door 29 is slidably mounted in guide grooves 30, formed internally of the cabinet in the respective side walls 31 thereof. Metal guides 32 form the guide channels, these metal guides being embedded in the respective cabinet sides 31—31. The opening 23 is of less width than the internal width of the cabinet so as to provide overhanging forward wall portions 33, behind which the door 29 operates.

The door is made up of a series of transverse slats 34 which form the front thereof. These slats are flexibly joined by a backing unit 35 formed of flexible, corrugated sheets 36 and flat sheets 36<sup>a</sup> of insulating material, forming a laminated backing medium.

In order to maintain the door in sealed engagement with the inner margin of the door opening, spring operated sealing strips 37 are provided, one along each vertical edge margin of the door. The strips consist of lengths of channel element 38. The rear flange 39 of each channel element is longer than the forward flange. A rubber strip 40 is secured between the arms of each channel element and projects forwardly, beyond the respective channel element, for engagement with the respective inner edge margins of the door. A rubber strip 41 is mounted in a groove on the inner side of each overhanging portion 33 of the forward cabinet wall for sealing engagement with the forward face of the door.

The sealing strips 37 are slidably mounted on pins 42, projecting from the respective side walls of the cabinet. Brackets 43, extended angularly upwardly from the rear of the strips 37, are mounted on the pins 42, which pass through slots 44 of the brackets. Springs 45 are mounted, under compression, between fixed abutments 46 and rear flanges 47 of the brackets. The springs are held in centered position by means of studs projecting from the respective elements.

In order to release the door from the pressure of the sealing strips 37—37, spreading devices 48, 48 are provided. These devices are in the form of brackets (see Figures 7 and 13), one at each lower corner of the door, and they incorporate spaced rollers 49. The brackets include flanges for attachment of the brackets to the lower edge of the door. The distance between the outer peripheries of the spaced rollers is greater than the distance between the sealing strips so that, as the door is raised, the rear sealing strips are moved away from and out of contact with the door, permitting free sliding motion thereof.

As shown in Figure 7, the lower inner edges of the strips are inclined, as at 50, and the lower portions 51 of the guide rails are also inclined outwardly, providing clearance for the rollers when the door is closed. This permits the sealing strips to perform their sealing functions. As the door is raised, the rollers ride up the inclined surfaces and accomplish the spreading action heretofore described.

The side guide elements or grooves are continued across and within the top of the refrigerator, as at 52, joining the vertical guides on curves of considerable radius (see Figure 2).

The top structure is fabricated for housing the door as it is raised. The top wall portion of the food chamber 53 is curved downwardly at its forward end, as at 54, for overhanging the upper rear edge margin of the door when fully closed (see Figure 2). The guide grooves and clearance passageway for the door curve downwardly at the rear of the refrigerator (see Figure 4). Since the door is flexible longitudinally, it can slide around the bends of the guideways.

The door is raised and lowered by a connection of the following nature. Flexible strips 55, one for each side of the door, are connected to the door at its upper edge (see Figure 2). These strips are supported and guided on the extended flanges 56, of angle iron pieces 57, secured to the inner walls of the cabinet and following the curvatures of the guide ways 52—52, respectively. Displacement of the strips 55 is prevented by the provision of guide plates 58 and spacers 59, secured on the flanges 56 of the angle irons to provide a guide groove in which the operating strips slide (see Figure 10). These strips 55 are connected across the rear of the refrigerator by a strap 60 (see Figure 3).

As detailed in Figure 9, angular extensions 61 are provided for each operating strip 55, to which extensions the respective ends of the strap are connected by screws 62. The forward ends of the strips 55 are connected to the top of the door in somewhat the same manner as the rear with the exception that the cross strap is secured across the top of the door. This cross strap is secured to lateral extensions of the strips 55 corresponding to the extensions 61 shown at the rear of the strips. A lazy tong or toggle mechanism 63 is mounted for vertical movement on the back of the refrigerator. The upper end of the toggle or lazy tong is pivotally attached centrally of the strap 60. The lower end is attached to two sets of leverages, one for raising and the other for lowering. The toggle mechanism operates on a pivot pin 64, as a part of a bracket 65, fixed to the rear side of the refrigerator, the pivotal point being at the next linkage above the lower connected end of the toggle.

The guides for the operating strips are continued, as at 65, down the rear wall of the cabinet at each side thereof. The door raising leverage consists of a lever 74, pivoted on a bracket 75 on the bottom of the refrigerator, and includes a foot treadle portion 76 at its forward end. The rear end of this lever 74 is connected to the lower end of the lazy tong by a link 77.

The door lowering leverage consists of a foot-operated lever 66, pivotally mounted on a bracket 67, fixed to the bottom of the refrigerator. A treadle portion for foot contact is provided at the forward end of the lever, as at 68. The rear end of the lever 66 is connected to a lever 69, pivotally mounted on the back of the refrigerator by means of a link 70.

A bracket 71 provides the pivotal mounting of the lever 69 and includes a pivot pin 72 disposed in a longitudinal slot 73 of the lever 69, permitting sliding as well as pivotal movement to allow the end of the lever 69 which is connected to the lower end of the toggle or lazy tong movement to travel in a vertical path, as opposed to an arcuate path.

The weight of the operating mechanism is calculated to offset the weight of the door so that a balanced condition exists, making it possible to operate the door through the motion increasing mechanism, namely, the lazy tong, without undue

effort. Long levers are provided between the foot and the lazy tong. The operator can place considerable pressure on the foot-operated levers, that is, practically his or her entire weight.

5 There is enough friction between the door and its guides for causing the door to remain in any position at which it is left. When the door is opened the lazy tong mechanism assumes the position shown in Figure 5, and the door is then  
10 disposed in a horizontal position within the top of the refrigerator.

If desired, the parts can be reversed, as shown in Figures 14 and 15; that is to say, the refrigerator unit 25 may be mounted in the top of the refrigerator, within a compartment 30. The guide tracks for the door are then disposed across the lower end of the refrigerator, beneath the floor 31 of the food compartment. The same mechanisms are employed as in the previous  
20 form. In this form, a sealing strip 32, disposed across the inner end of the door, engages for sealing purposes, a lip 33 on the floor of the food compartment.

Having described my invention, I claim:

25 1. In a refrigerator, a cabinet structure including a food compartment and an opening thereto, a door disposed across said opening within the cabinet, said cabinet including guide grooves for said door extending vertically at each  
30 side of the opening and continuously across and within the upper portion of the cabinet, said door being flexible longitudinally whereby it can be moved in the guides, a toggle device disposed for vertical movement at the back of the refrigerator  
35 and attached to one end of the door, and respective mechanisms for raising and lowering said toggle device for moving the door from horizontal position to vertical or closing position and  
40 from vertical or closing position to horizontal position respectively.

2. In a refrigerator of the type including a mechanically cooled cabinet structure, said cabinet including a food compartment having an opening in its forward wall, said opening of less  
45 width than the interior width of the food compartment, a slidably mounted door lying against the margins of said opening, spring pressed sealing strips disposed along the side edges of the door and engaged against the margins thereof,  
50 spreading devices at the end of the door for displacing said sealing strips, whereby they do not interfere with sliding movement of the door, said door of flexible construction longitudinally,  
55 guide means for the door in its normally closed position, said guide means continuing across the top of the refrigerator, a foot treadle for raising

the door, a foot treadle for lowering the door, and a motion increasing mechanism attached to the treadles and the door.

3. In a refrigerator of the class described, a cabinet structure having an opening in its forward wall, a slidably mounted door disposed over  
5 said opening and lying against the inner margins thereof, sealing means for urging said sliding door against said margins, foot operated treadle mechanism for moving the door from its position  
10 across said opening, and spreader means on the door for displacing said sealing means as the door is opened.

4. In a refrigerator of the type including a mechanically cooled cabinet structure, said cabinet  
15 including a food compartment having an opening in its forward wall, said opening of less width than the interior width of the food compartment, a slidably mounted door lying against the margins of said opening, yieldably mounted  
20 sealing strips disposed along each side edge of the door and engaged against the respective inner edge margins thereof, spreading devices at the lower ends of the door for displacing said sealing strips, whereby they do not interfere with  
25 sliding movement of the door, said door of flexible construction, guide means for the door containing the same in its normally closed position and continuing within the refrigerator, a foot treadle for opening the door, a foot treadle for  
30 closing the door, and a motion increasing mechanism connecting the treadles and the door.

5. In a refrigerator structure, a cabinet including a food compartment having an opening thereto, a longitudinally flexible door disposed  
35 across said opening and engaging the inner surface of the forward wall of the cabinet, said cabinet including grooves for guiding said door, means for sliding said door in said grooves, and spring-urged sealing strips mounted within the  
40 cabinet yieldingly engaging the margins of the door for sealing the same when in closed position.

6. In a refrigerator, a cabinet structure including a food compartment having an opening for access thereto, a door slidably disposed across  
45 said opening within said cabinet, means for guiding said door, a toggle mechanism connected to one end of the door, foot treadle mechanisms connected to the operating end of the toggle mechanism, one of said foot treadle mechanisms  
50 closing the door upon downward movement and the other opening the door upon downward movement, said foot treadle mechanisms conveniently located for foot operation.

L. LEE STRATTON.