



## INTERNATIONAL APPLICATION PUBLISHED UNDER THE PATENT COOPERATION TREATY (PCT)

<p>(51) International Patent Classification <sup>6</sup> : C12M 1/00, 1/40, C12Q 1/04, 1/08, 1/14, 1/24</p>	A1	<p>(11) International Publication Number: <b>WO 97/17425</b></p> <p>(43) International Publication Date: 15 May 1997 (15.05.97)</p>
<p>(21) International Application Number: PCT/US96/15318</p> <p>(22) International Filing Date: 25 September 1996 (25.09.96)</p> <p>(30) Priority Data: 08/555,734 9 November 1995 (09.11.95) US</p> <p>(71) Applicant: Infectech, Inc. [US/US]; Suite 2, 87 Stambaugh Avenue, Sharon, PA 16146 (US).</p> <p>(72) Inventors: FELDER, Mitchell, S.; 3694 McConnell Road, Hermitage, PA 16148 (US). OLLAR, Robert-A.; 122 Cornelia Lane, Milford, PA 18337 (US).</p> <p>(74) Agent: RADACK, David, V.; Eckert Seamans Cherin &amp; Mellott, 42nd floor, 600 Grant Street, Pittsburgh, PA 15219 (US).</p>		<p>(81) Designated States: AL, AM, AT, AU, AZ, BA, BB, BG, BR, BY, CA, CH, CN, CU, CZ, DE, DK, EE, ES, FI, GB, GE, HU, IL, IS, JP, KE, KG, KP, KR, KZ, LC, LK, LR, LS, LT, LU, LV, MD, MG, MK, MN, MW, MX, NO, NZ, PL, PT, RO, RU, SD, SE, SG, SI, SK, TJ, TM, TR, TT, UA, UG, UZ, VN, ARIPO patent (KE, LS, MW, SD, SZ, UG), Eurasian patent (AM, AZ, BY, KG, KZ, MD, RU, TJ, TM), European patent (AT, BE, CH, DE, DK, ES, FI, FR, GB, GR, IE, IT, LU, MC, NL, PT, SE), OAPI patent (BF, BJ, CF, CG, CI, CM, GA, GN, ML, MR, NE, SN, TD, TG).</p> <p><b>Published</b> <i>With international search report.</i></p>
<p>(54) Title: METHOD AND APPARATUS TO DETERMINE PARAFFINOPHILIC MICROORGANISMS</p>		
<p>(57) Abstract</p> <p>A method of determining the presence of a paraffinophilic microorganism in a specimen taken from a patient. The method includes providing a receptacle containing an aqueous solution and adjusting the solution to mimic the <i>in vivo</i> clinical conditions of the patient. The method then further includes inoculating the solution with the specimen and then placing in the receptacle a paraffin coated slide to bait the paraffinophilic microorganism. The slide is then analyzed after exposure to the specimen to determine the presence or absence of the paraffinophilic microorganism. An associated apparatus is also disclosed.</p>		

**FOR THE PURPOSES OF INFORMATION ONLY**

Codes used to identify States party to the PCT on the front pages of pamphlets publishing international applications under the PCT.

AM	Armenia	GB	United Kingdom	MW	Malawi
AT	Austria	GE	Georgia	MX	Mexico
AU	Australia	GN	Guinea	NE	Niger
BB	Barbados	GR	Greece	NL	Netherlands
BE	Belgium	HU	Hungary	NO	Norway
BF	Burkina Faso	IE	Ireland	NZ	New Zealand
BG	Bulgaria	IT	Italy	PL	Poland
BJ	Benin	JP	Japan	PT	Portugal
BR	Brazil	KE	Kenya	RO	Romania
BY	Belarus	KG	Kyrgystan	RU	Russian Federation
CA	Canada	KP	Democratic People's Republic of Korea	SD	Sudan
CF	Central African Republic	KR	Republic of Korea	SE	Sweden
CG	Congo	KZ	Kazakhstan	SG	Singapore
CH	Switzerland	LI	Liechtenstein	SI	Slovenia
CI	Côte d'Ivoire	LK	Sri Lanka	SK	Slovakia
CM	Cameroon	LR	Liberia	SN	Senegal
CN	China	LT	Lithuania	SZ	Swaziland
CS	Czechoslovakia	LU	Luxembourg	TD	Chad
CZ	Czech Republic	LV	Latvia	TG	Togo
DE	Germany	MC	Monaco	TJ	Tajikistan
DK	Denmark	MD	Republic of Moldova	TT	Trinidad and Tobago
EE	Estonia	MG	Madagascar	UA	Ukraine
ES	Spain	ML	Mali	UG	Uganda
FI	Finland	MN	Mongolia	US	United States of America
FR	France	MN	Mongolia	UZ	Uzbekistan
GA	Gabon	MR	Mauritania	VN	Viet Nam

- 1 -

METHOD AND APPARATUS TO DETERMINE PARAFFINOPHILIC  
MICROORGANISMS

BACKGROUND OF THE INVENTION

This invention relates to a method of identifying a paraffinophilic microorganism using various milieus and an associated apparatus and, more particularly, to a receptacle  
5 containing an aqueous solution that mimics the in vivo conditions of a patient. A paraffin coated slide is used to bait a paraffinophilic organism that can grow on the slide. The organism then can be identified by a number of different methods.

10 United States Patent Nos. 5,153,119 and 5,316,918, the disclosures of which are incorporated by reference herein, disclose methods and apparatus for identifying and testing the antibiotic sensitivity of *Mycobacterium avium-intracellulare* ("MAI"). One of the co-inventors herein, Robert-A. Ollar, was  
15 the named inventor on these patents. The method of identifying MAI includes placing a paraffin coated slide in a receptacle containing a sterile aqueous solution inoculated with a specimen from a patient and analyzing the slide after exposure to the specimen to determine the presence or absence  
20 of MAI. The analysis step involves performing a number of speciation assays, such as a tellurite reduction test. The method for testing the sensitivity of MAI to different antimicrobial agents and dosages thereof includes providing a plurality of test tubes adapted to contain an amount of an  
25 antimicrobial agent to be tested and MAI to be assayed and a separate paraffin coated slide adapted for placement in each of the test tubes. Observing the growth of MAI on the slide can be used to determine the concentration of the antimicrobial agent necessary to resist MAI growth on the slide.

- 2 -

The inventions provide effective, efficient and economical methods for identifying MAI and testing MAI for antimicrobial agent sensitivity. These methods avoid the use of expensive, complicated equipment, and thus can be used in places such as field hospitals and third world locations where the more expensive and hard to use equipment is not available.

Despite the effectiveness of the methods and apparatus disclosed in the above-mentioned patents, it would be desired to refine the process of identifying MAI, as well as other paraffinophilic microorganisms.

### SUMMARY OF THE INVENTION

The invention has met or surpassed the above-mentioned need as well as others. The method of determining the presence of a paraffinophilic microorganism in a specimen taken from a patient includes providing a receptacle containing an aqueous solution and adjusting the solution to mimic the *in vivo* clinical conditions of the patient. The method further includes inoculating the solution with the specimen and then placing in the receptacle a paraffin coated slide. The slide is then analyzed after exposure to the specimen to determine the presence or absence of the microorganism.

An apparatus to facilitate determination of the presence or a paraffinophilic microorganism in a specimen taken from a patient is also provided. The apparatus comprises a receptacle for holding an aqueous solution and a paraffin coated slide adapted to be placed in the receptacle. The apparatus further comprises means for adjusting the aqueous solution to mimic the *in vivo* clinical conditions of the patient.

- 3 -

### BRIEF DESCRIPTION OF THE DRAWING

A full understanding of the invention can be gained from the following detailed description of the invention when read in conjunction with the accompanying lone drawing which shows a front elevational view of a test tube holding a paraffin coated slide in an aqueous solution inoculated with a specimen.

### DETAILED DESCRIPTION

As used herein, the term "patient" refers to a member of the animal kingdom, including human beings whose body specimen is being processed by the method and apparatus of the invention.

As used herein, the term "paraffinophilic" means an organism that can employ paraffin as a source of carbon in a basal salt media, devoid of other forms of carbon, the organism can be bacterial or fungal in nature.

The method and apparatus of the invention provide an efficient, effective and economical way of identifying a paraffinophilic microorganism. Referring to the lone Figure, one embodiment of a paraffinophilic microorganism identification apparatus 10 is shown. The apparatus 10 includes a standard test tube 12 which contains an aqueous solution 13 (such as distilled water) and a cotton plug 16 to seal the test tube 12. A specimen to be tested for the presence or absence of a paraffinophilic microorganism is inoculated into the aqueous solution 13. A slide 18, having a coating of paraffin 20 is then placed into the test tube 12. It will be appreciated that the aqueous solution 13 should not contain any carbon source, as it is desired to provide a sole carbon source on the slide in order to effectively grow the microorganism to be identified on the slide 18 and not in the aqueous solution 13. Growth on the paraffin coated slide 18 can be analyzed to determine the presence or absence of a

- 4 -

paraffinophilic microorganism. Such tests to analyze the growth can include tests such as DNA hybridization or can be tests for specific paraffinophilic microorganisms, such as MAI, as is disclosed in United States Patent Nos. 5,153,119 and 5,316,918, the disclosures of which are specifically incorporated by reference herein.

The specimen to be inoculated into the test tube 12 can be a blood sample; any biopsy or tissue specimen; stomach fluid; urine; cerebral spinal fluid; nasopharyngeal mucosa or saliva. These specimens can be obtained from the patient in the doctor's office or in the emergency room of a hospital, for example, by known techniques in known standard ways.

The paraffin 20 included on the slide is used to bait the paraffinophilic microorganism. For example, the paraffin can be used to bait MAI. It will be appreciated that the aqueous solution 13 should not contain any carbon source, as it is desired to provide a sole carbon source on the slide in order to effectively identify the microorganism.

In accordance with the invention, the aqueous solution 13 can be adjusted to mimic the in vivo "clinical conditions" of the patient. By "clinical conditions" it is meant at least one of the following: (i) the pH of the in vivo milieu of the patient where the paraffinophilic microorganism can be found and (ii) the electrolyte levels of a patient's blood where paraffinophilic microorganisms can be found. Adjusting the aqueous solution can be effected by numerous different methods. Adjusting the pH of the aqueous solution can be accomplished by adding hydrochloric acid (HCl) to obtain a more acidic solution or by adding sodium hydroxide (NaOH) or potassium hydroxide (KOH) in order to obtain a more basic solution. Electrolytes such as one or more selected from the group consisting of sodium, potassium, chloride, magnesium, phosphate and calcium, can be added to the solution in desired quantities in order to mimic the electrolytes in

- 5 -

the blood of a patient from which a blood sample which may contain the microorganism is obtained.

Paraffinophilic microorganisms that can be identified using the method of the invention include at least one of the paraffinophilic microorganisms selected from the group consisting of *Micrococcus Paraffinae*; *Corynebacterium Simplex*; Ahnl; *Mycococcus (Rhodococcus) Cinnabareus*; Ahnl. *Mycococcus (Rhodoc) Rhodochrous*; *Mycobact. Perrugosum Var. Athanicum*; *Mycobact. Rubrum Var. Propanicum*; *Mycobacterium Hyalinum*; *Mycobacterium Lacticola*; *Mycobacterium Album*, *M. Luteum*; *Mycobacterium Microti*; *Mycobacterium Rubrum*, *Mycobacterium Phlei.*; *Mycobacterium Phlei*, *M. Smegmatis*; *Mycobacterium Testudo*; *Mycobacterium-Avium-Intracellulare*; *Nocardia Spp.*; *Actinomyces*; *Candida Lipolytica*; *Candida Tropicalis*, *Torulopsis Colliculosa*; *Monila Sp.*, *Hansenula Sp.*, *Torula rossa*; *Penicillium Sp.*; IHNL. *Aspergillus Flavus*; *Aspergillus sp.*, *Penicillium Sp.*; *Citromyces Sp.*, *Scopulariopsis Sp.*; *Pseudomonas Fluorescens Liquefaciens*; Ahnl, *Pem. Fluorescens Denitrificans*; *Pseudomonas Aeruginosa*.

20

### EXAMPLE 1

An AIDS patient comes to an emergency room at a hospital complaining of severe abdominal pain. A gastroenterologist uses a gastrointestinal scope to obtain a specimen of the patient's stomach fluid. The scope indicates that the pH in the patient's stomach is 1.5. In the meantime, a lab technician using the apparatus of the Figure adjusts the pH of the aqueous solution 13 by adding HCl thereto so that the aqueous solution 13 has a pH of 1.5. Thus, the pH in the patient's stomach is mimicked by the pH of the aqueous solution in the apparatus shown in the Figure. After this, the specimen of stomach fluid taken by the gastroenterologist from the patient is inoculated into the receptacle 12 holding a paraffin coated slide 18. After about eight days a growth appears on the paraffin coated slide 18. The growth is then

- 6 -

analyzed by the method and apparatus disclosed in United States Patent No. 5,153,119 to determine whether MAI is present.

### EXAMPLE 2

5           An AIDS patient comes to an emergency room  
complaining of high fever and apparently has pneumonia. The  
physician suspects that there is an infection caused by  
*Nocardia bactereremia*. As is standard in almost every  
emergency room, a chemical screen ("CSS") is performed on a  
10 blood specimen obtained from the patient. The CSS lists the  
electrolyte content of the patient's blood. The electrolyte  
content is communicated to a lab technician who in turn  
adjusts the aqueous solution 13 in the receptacle 12 holding  
the paraffin coated slide 18. For example, the CSS reveals  
15 that the patient has a sodium level of 120. The lab  
technician adjusts the sodium level of the aqueous solution  
(for example, distilled water) by adding sodium thereto in  
order to mimic the 120 level of sodium found in the patient's  
blood. The blood specimen is then inoculated into the  
20 adjusted aqueous solution. After about two days a growth  
appears. The growth is analyzed and is found to be, indeed,  
*Nocardia bactereremia*.

It will be appreciated that a method for identifying  
a paraffinophilic microorganism has been disclosed in which  
25 the aqueous solution in which the paraffin coated slide and  
the microorganism are placed is adjusted to mimic the *in vivo*  
clinical conditions of a patient from whom the specimen  
containing the paraffinophilic microorganism to be identified  
is obtained. The method is effective and efficient and does  
30 not involve the use of expensive and complicated equipment.  
An associated apparatus is also disclosed.

While specific embodiments of the invention have  
been disclosed, it will be appreciated by those skilled in the  
art that various modifications and alterations to those



- 7 -

details could be developed in light of the overall teachings of the disclosure. Accordingly, the particular arrangements disclosed are meant to be illustrative only and not limiting as to the scope of the invention which is to be given the full  
5 breadth of the appended claims and any and all equivalents thereof.

- 8 -

## WHAT IS CLAIMED IS:

1. A method of determining the presence or absence of a paraffinophilic microorganism in a specimen taken from a patient, said method comprising:
  - 5 providing a receptacle containing an aqueous solution;
  - adjusting said aqueous solution to mimic the in vivo clinical conditions of said patient;
  - inoculating said solution with said specimen;
  - 10 placing into said receptacle a paraffin coated slide; and
  - analyzing said slide after exposure to said specimen to determine the presence or absence of said microorganism.
- 15 2. The method of Claim 1, including employing as said specimen one selected from the group consisting of blood, stomach fluid, urine, cerebral spinal fluid, nasopharyngeal mucosa and saliva.
- 20 3. The method of Claim 1, including effecting said adjusting of said aqueous solution by altering the pH of said aqueous solution.
4. The method of Claim 1, including effecting said adjusting of said aqueous solution by adding chemicals to said solution to mimic the electrolyte level in said patient's blood.
- 25 5. The method of Claim 4, including employing as said chemicals at least one of the group consisting of sodium, potassium, chloride, magnesium, phosphate and calcium.

- 9 -

6. The method of Claim 1, including  
employing said method to determine the presence  
or absence of at least one member of the group consisting of  
*Micrococcus Paraffinae*; *Corynebacterium Simplex*; Ahnl;  
5 *Mycococcus (Rhodococcus) Cinnabareus*; Ahnl. *Mycococcus*  
*(Rhodoc) Rhodochrous*; *Mycobact. Perrugosum Var. Athanicum*;  
*Mycobact. Rubrum Var. Propanicum*; *Mycobacterium Hyalinum*;  
*Mycobacterium Lacticola*; *Mycobacterium Album*, *M. Luteum*;  
*Mycobacterium Microti*; *Mycobacterium Rubrum*,  
10 *Mycobacterium Phlei.*; *Mycobacterium Phlei*, *M. Smegmatis*;  
*Mycobacterium Testudo*; *Mycobacterium-Avium-Intracellulare*;  
*Nocardia Spp.*; *Actinomyces*; *Candida Lipolytica*; *Candida*  
*Tropicalis*, *Torulopsis Colliculosa*; *Monila Sp.*, *Hansenula Sp.*,  
*Torula rossa*; *Penicillium Sp.*; IHNL. *Aspergillus Flavus*;  
15 *Aspergillus sp.*, *Penicillium Sp.*; *Citromyces Sp.*,  
*Scopulariopsis Sp.*; *Pseudomonas Fluorescens Liquefaciens*;  
Ahnl, *Pem. Fluorescens Denitrificans*; *Pseudomonas Aeruginosa*.

7. An apparatus to facilitate determination of the  
presence or absence of a paraffinophilic microorganism in a  
20 specimen taken from a patient, said apparatus comprising:  
a receptacle for holding an aqueous solution;  
a paraffin coated slide adapted to be placed in  
said receptacle; and  
means for adjusting said aqueous solution to  
25 mimic the in vivo clinical conditions of said patient.

8. The apparatus of Claim 7, wherein  
said adjusting means includes chemicals to  
adjust the pH of said aqueous solution.

9. The apparatus of Claim 8, wherein  
30 said chemicals are selected from the group  
consisting of HCl, KOH and NaOH.

- 10 -

10. The apparatus of Claim 7, wherein  
said adjusting means includes chemicals to  
mimic the electrolyte level in said patient's blood.

5 11. The apparatus of Claim 10, wherein  
said chemicals include at least one of the  
group consisting of sodium, potassium, chloride, magnesium,  
phosphate and calcium.

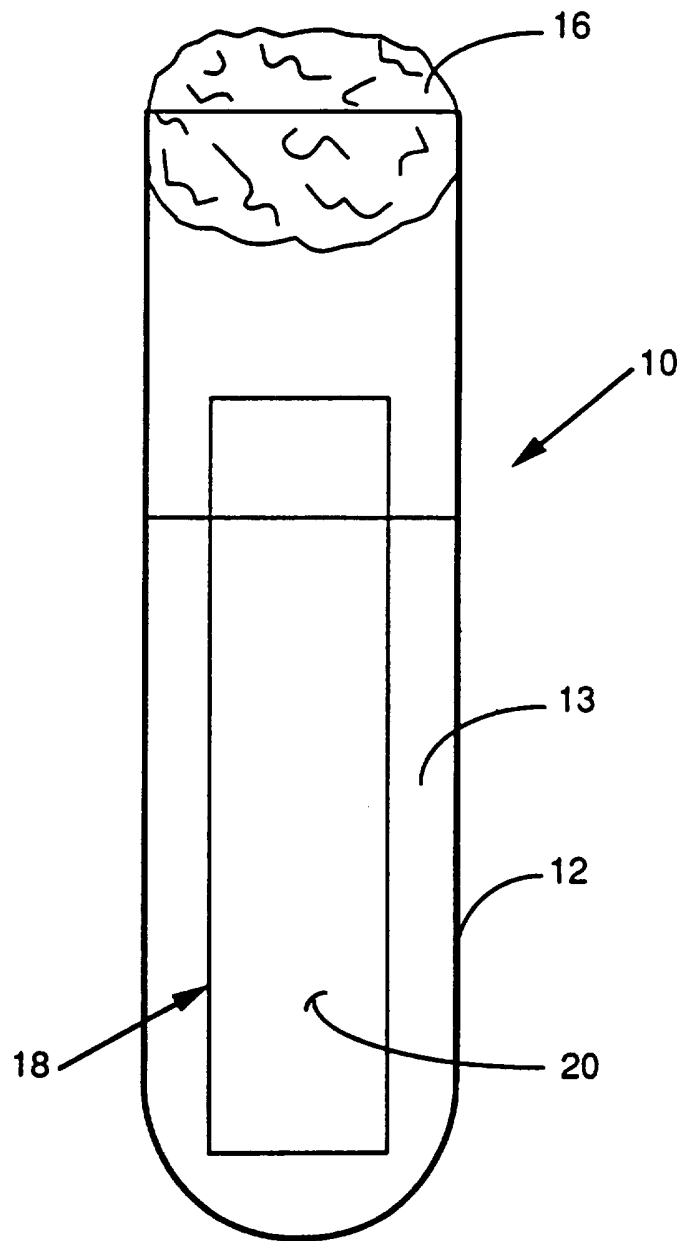

# INTERNATIONAL SEARCH REPORT

Int. l. application No.  
PCT/US96/15318

**A. CLASSIFICATION OF SUBJECT MATTER**

IPC(6) : C12M 1/00, 1/40; C12Q 1/04, 1/08, 1/14, 1/24  
US CL : 435/30, 34, 36, 40, 287.9, 288.1, 288.3, 801, 863

According to International Patent Classification (IPC) or to both national classification and IPC

**B. FIELDS SEARCHED**

Minimum documentation searched (classification system followed by classification symbols)

U.S. : 435/30, 34, 36, 40, 287.9, 288.1, 288.3, 801, 863

Documentation searched other than minimum documentation to the extent that such documents are included in the fields searched

Electronic data base consulted during the international search (name of data base and, where practicable, search terms used)

APS, MEDLINE, CHEM ABSTRACT, BIOSIS

**C. DOCUMENTS CONSIDERED TO BE RELEVANT**

Category*	Citation of document, with indication, where appropriate, of the relevant passages	Relevant to claim No.
Y	US 5,153,119 A (R. OLLAR) 06 October 1992 (06.10.92), see the abstract and Figure 1.	1-11
A	US 5,316,918 A (R. OLLAR) 31 May 1994 (31.05.94).	1-11
A, P	US 5,472,877 A (R. OLLAR) 05 December 1995 (05.12.95).	1-11

Further documents are listed in the continuation of Box C.       See patent family annex.

* Special categories of cited documents:	*T* later document published after the international filing date or priority date and not in conflict with the application but cited to understand the principle or theory underlying the invention
*A* document defining the general state of the art which is not considered to be of particular relevance	*X* document of particular relevance; the claimed invention cannot be considered novel or cannot be considered to involve an inventive step when the document is taken alone
*E* earlier document published on or after the international filing date	*Y* document of particular relevance; the claimed invention cannot be considered to involve an inventive step when the document is combined with one or more other such documents, such combination being obvious to a person skilled in the art
*L* document which may throw doubts on priority claim(s) or which is cited to establish the publication date of another citation or other special reason (as specified)	*Z* document member of the same patent family
*O* document referring to an oral disclosure, use, exhibition or other means	
*P* document published prior to the international filing date but later than the priority date claimed	

Date of the actual completion of the international search 23 OCTOBER 1996	Date of mailing of the international search report <b>31 OCT 1996</b>
------------------------------------------------------------------------------	--------------------------------------------------------------------------

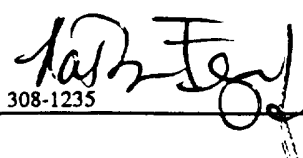
Name and mailing address of the ISA/US Commissioner of Patents and Trademarks Box PCT Washington, D.C. 20231 Facsimile No. (703) 305-3230	Authorized officer RALPH GITOMER  Telephone No. (703) 308-1235
-------------------------------------------------------------------------------------------------------------------------------------------------------	-----------------------------------------------------------------------------------------------------------------------------------------------------------