



- (51) **International Patent Classification:**
E21B 23/01 (2006.01) *E21B 33/10* (2006.01)
- (21) **International Application Number:**
PCT/US2014/037007
- (22) **International Filing Date:**
6 May 2014 (06.05.2014)
- (25) **Filing Language:** English
- (26) **Publication Language:** English
- (71) **Applicant:** HALLIBURTON ENERGY SERVICES, INC. [US/US]; 10200 Bellaire Blvd, Houston, Texas 77072 (US).
- (72) **Inventors:** KARTHA, Nikhil M.; Block 176, #06-370, Boon Lay Drive, Singapore 640176 (SG). HOLLY, Mark S.; 5942 Hollister Circle, Houston, Texas 77040 (US). THOMAS, Sean Gregory; 1517 Sleepy Hollow Drive, Allen, Texas 75002 (US). CLEMENS, Jack; 906 Scenic Ranch Circle, Fairview, Texas 75069 (US).
- (74) **Agents:** REEVES, Matthew G. et al.; Locke Lord LLP, 600 Travis, Suite 2800, Houston, Texas 77002-3095 (US).
- (81) **Designated States** (unless otherwise indicated, for every kind of national protection available): AE, AG, AL, AM,

AO, AT, AU, AZ, BA, BB, BG, BH, BN, BR, BW, BY, BZ, CA, CH, CL, CN, CO, CR, CU, CZ, DE, DK, DM, DO, DZ, EC, EE, EG, ES, FI, GB, GD, GE, GH, GM, GT, HN, HR, HU, ID, IL, IN, IR, IS, JP, KE, KG, KN, KP, KR, KZ, LA, LC, LK, LR, LS, LT, LU, LY, MA, MD, ME, MG, MK, MN, MW, MX, MY, MZ, NA, NG, NI, NO, NZ, OM, PA, PE, PG, PH, PL, PT, QA, RO, RS, RU, RW, SA, SC, SD, SE, SG, SK, SL, SM, ST, SV, SY, TH, TJ, TM, TN, TR, TT, TZ, UA, UG, US, UZ, VC, VN, ZA, ZM, ZW.

- (84) **Designated States** (unless otherwise indicated, for every kind of regional protection available): ARIPO (BW, GH, GM, KE, LR, LS, MW, MZ, NA, RW, SD, SL, SZ, TZ, UG, ZM, ZW), Eurasian (AM, AZ, BY, KG, KZ, RU, TJ, TM), European (AL, AT, BE, BG, CH, CY, CZ, DE, DK, EE, ES, FI, FR, GB, GR, HR, HU, IE, IS, IT, LT, LU, LV, MC, MK, MT, NL, NO, PL, PT, RO, RS, SE, SI, SK, SM, TR), OAPI (BF, BJ, CF, CG, CL, CM, GA, GN, GQ, GW, KM, ML, MR, NE, SN, TD, TG).

Published:
— with international search report (Art. 21(3))

(54) **Title:** DOWNHOLE ANCHOR

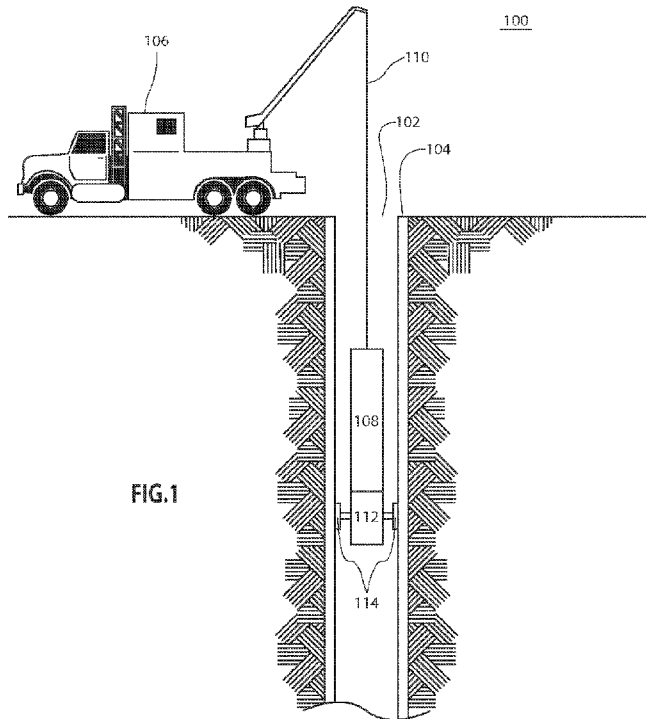

(57) **Abstract:** The disclosure provides a downhole anchoring apparatus for use in a downhole tool. An example downhole anchoring apparatus may include a housing with a hub provided within the housing. The hub may be arranged to rotate in a bi-directional fashion about a longitudinal axis. The downhole anchoring apparatus may also include a deployment linkage. The deployment linkage may be coupled to the hub by a hinge so that when the hub is rotated in a first direction, a distal end of the deployment linkage is extended radially outward from the central axis, and when the hub is rotated in a second direction, the distal end of the deployment linkage is retracted toward the central axis.

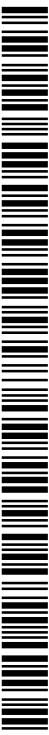

DOWNHOLE ANCHOR

Inventors: Nikhil M. Kartha, Mark S. Holly, Sean G. Thomas, Jack Clemens

5

TECHNICAL FIELD

[0001] The embodiments disclosed herein relate generally to downhole tools for oil and gas wells, and, in particular to devices and methods for anchoring the tools in a wellbore casing section.

BACKGROUND

10

[0002] Downhole tools are often used to provide operations in oil and gas wells. Wirelines or slicklines are used to position downhole tools at a desired location in the wellbore. The desired location in the wellbore may be either cased or uncased, depending on the nature of the operation to be performed by the tool. In order to perform the desired operation, many wireline or slickline tools must be anchored in the wellbore to hold them

15 in the correction wellbore location. This means the anchor must be able to resist not only unwanted movement of the tool in the axial direction, but also rotational movement caused by torque on the tool during the operation.

BRIEF DESCRIPTION OF DRAWINGS

20

[0003] FIG. 1 is a diagram showing a downhole anchoring system according to an embodiment;

[0004] FIG. 2 is a diagram illustrating a downhole anchor according to an embodiment with the deployment linkages retracted;

[0005] FIG. 3 is a diagram illustrating a downhole anchor according to an embodiment with the deployment linkages extended; and

25

[0006] FIG. 4 is a diagram illustrating a downhole anchor according to an embodiment arranged to provide a mechanism for conveyance.

DETAILED DESCRIPTION OF DISCLOSED EMBODIMENTS

30

[0007] As an initial matter, it will be appreciated that the development of an actual, real commercial application incorporating aspects of the disclosed embodiments will require many implementation-specific decisions to achieve the developer's ultimate goal for the commercial embodiment. Such implementation-specific decisions may include, and likely are not limited to, compliance with system-related, business-related, government-related and other constraints, which may vary by specific implementation,

location and from time to time. While a developer's efforts might be complex and time-consuming in an absolute sense, such efforts would nevertheless be a routine undertaking for those of skill in this art having the benefit of this disclosure.

5 [0008] It should also be understood that the embodiments disclosed and taught herein are susceptible to numerous and various modifications and alternative forms. Thus, the use of a singular term, such as, but not limited to, "a" and the like, is not intended as limiting of the number of items. Similarly, any relational terms, such as, but not limited to, "top," "bottom," "left," "right," "upper," "lower," "down," "up," "side," and the like, used in the written description are for clarity in specific reference to the drawings and are not intended to limit the scope of the disclosure.

10 [0009] In one embodiment of the disclosure, there is provided a downhole anchor for anchoring a downhole tool in a desired section of the wellbore. FIG. 1 shows an anchoring system 100 according to an embodiment of the disclosure. Wellbore 102 of an oil and gas well is lined with casing 104. A wireline truck 106 may be used to deploy
15 activation tool 108 at a desired location within wellbore 102 from wireline 110. An activation tool can be any type of downhole tool that is activated downhole to perform a desired operation. Examples of actuation tools include any number of well intervention tools, such, as tools for setting packers, washing tools, milling tools, data gathering or sampling tools, and so forth. Generally, any downhole tool that requires anchoring may
20 be used in embodiments of the system. Further, one or more anchors may be provided as necessary to maintain the activation tool in place. Similarly, in other embodiments, more than one activation tool may be included in the work string. For simplicity, in the embodiment depicted in FIG. 1, a single anchor 112 is provided to hold activation tool 108 in place. Anchor 112 includes radially extending linkages 114 that cause slips to
25 engage the inner surface of wellbore casing 104 with sufficient force to hold activation tool 108 in place.

[0010] FIG. 2 shows a cross-sectional view of an anchor according to an embodiment of the disclosure. The anchor 200 is positioned in wellbore casing 202 by a wireline truck. The anchor 200 includes a rotatable hub 204. A plurality of deployment linkages
30 206 are attached to the rotatable hub 204 by hinges 208. The hub 204 is designed to rotate in both the clockwise and counter-clockwise directions about a central axis. The central axis is at the center of the rotatable hub 204. The central axis runs longitudinally with the tool and is generally aligned with the longitudinal axis of the wellbore. In the

embodiment shown in FIG. 1, the longitudinal axis of the wellbore 102 is depicted as being vertical, however, it will be understood that it is common to drill oil and gas wells at various inclinations, including horizontal, and that the inclination may vary at different depths. Thus, the longitudinal axis of the wellbore at a given section where the anchor is
5 deployed may have any inclination, and is not limited to vertical.

[0011] The distal end of each deployment linkage 206 is provided with a slip 210. The slips 210 are flexible and may be constructed from metal. The outer surface of slips 210 may include surface features, such as grooves, serrations or teeth, designed to grip the inner surface of the wellbore casing. In various embodiments, the surface features
10 may be optimized to resist torque or longitudinal movement of the tool depending on the operation the activation tool is to perform.

[0012] The hinges 208 coupling the deployment linkages 206 to the rotatable hub 204 include a pin that is oriented along the longitudinal axis, or central axis, of the anchor 200. This allows the deployment linkages 206 to pivot either clockwise or counter-
15 clockwise, while being restricted from linear motion in a longitudinal direction. Hinges 212 are used to couple the slips 210 to the distal end of deployment linkages 206. Hinges 212 are oriented in the same manner as hinges 208, and similarly allow slips 210 to rotate either clockwise or counter-clockwise. This allows slips 210 to adjust to match the curvature of the inner surface of wellbore casing 202 so that an optimal grip may be
20 achieved when the slips are engaged with the wellbore casing.

[0013] The embodiment shown in FIG. 2 shows an anchor 200 with the deployment linkages 206 fully retracted. This is the configuration in which the anchor 200 would be deployed into the wellbore. When the deployment linkages 206 are fully retracted, the slips 210 are drawn flush with the tool housing 214. The tool housing 214 may be
25 provided with slots or recesses to allow the slips 210 to be flush with the housing 214. This allows the anchor 200 to travel through the wellbore to a desired section where the downhole tool is to be activated without hanging up or snagging on other equipment or objects that might be in the wellbore.

[0014] When the downhole tool is located at the desired section of the wellbore where the operation is to be performed, the anchor is deployed. To deploy the anchor 200, the
30 rotatable hub 204 is rotated. In the embodiment shown in FIG. 2, the rotatable hub 204 is rotated counter-clockwise to extend the deployment linkages 206. The rotation may be caused by hydraulic or electromechanical equipment. The selection of the particular

equipment to rotate the rotatable hub 204 is a matter of design choice and within the capabilities of one of skill in the art.

5 [0015] As rotatable hub 204 is rotated counter-clockwise, deployment linkages 206 are extended radially through guides 216. Guides 216 are allowed to pivot because the relative angle of the deployment linkages 206 to the rotatable hub 204 will change as they extend, and retract, radially. Allowing the guides 216 to pivot will accommodate this change in relative angle. In another embodiment, the guide 216 may be a pair of rollers or similar bearings instead of, or in combination with, a channel or slot. In some implementations, the rollers may be fixed, but still accommodate the change in relative angle.

10 [0016] Guides 216 cause the deployment linkages 206 to extend radially outward from the central axis of the rotatable hub 204 and toward the inner surface of the wellbore casing. Hinges 212 allow the deployment linkages 206 to pivot so that the rotational movement of rotatable hub 204 is translated into linear movement of the deployment linkages 206 in the radial direction.

15 [0017] A deployed anchor 200 is shown in FIG. 3. Near the end of their travel, deployment linkages 206 cause slips 210 to engage the inner surface of the wellbore casing 202. Hinges 212 allow the slips 210 to adjust to fit the curved surface of the wellbore casing and grip effectively on its surface. Further rotation of rotatable hub 204 increases the force with which slips 210 are pressed against the wellbore casing. This allows well engineers to control the braking force by controlling the amount of rotation of rotatable hub 204. The radial motion of the deployment linkages 206 also allows the anchor 200 to effectively grip a range of casing diameters without any performance degradation. It further allows the anchor 200 to have a significantly higher holding resistance to torque in addition to the traditional axial direction. Because the force generated in the deployment linkages 206 can be significant, it is advantageous if deployment linkages 206 and hinges 208 are arranged so that the deployment linkages 206 transfer force to the hinge seat rather than the hinge pin.

20 [0018] As the anchor 200 is positioned by the wireline, the central axis of the anchor will likely not be centered with the longitudinal axis of the wellbore casing 202. It is important in many cases for the anchor 200, as well as the downhole tools it is anchoring, to be centered in the wellbore. Therefore, it is advantageous if the anchor 200 is designed to self-center when actuated. In the embodiment shown in FIGS. 2 – 3, self-centering is

achieved by using six deployment linkages 206 arranged evenly about rotatable hub 204. In other embodiments, different numbers of deployment linkages 206, such as three, five or seven, may also be used, but it is advantageous if they are arranged so that the anchor self-centers in the wellbore casing when deployed.

5 [0019] Once the slips 210 are engaged with wellbore casing 202, the rotatable hub 204 can be locked into position using various known mechanisms, such as clutches or no-backs. This enables the drive mechanism to be switched off while the anchor 200 is engaged, thus saving power.

10 [0020] To unlock the anchor 200, the rotatable hub 204 is rotated in the opposite direction, in this example, clockwise. This causes the deployment linkages 206 to radially retract through guides 216 until they cause slips 210 to reseat into the slots or recesses in housing 214. At this point, the anchor 200, along with any downhole tools in the work string, may be withdrawn or moved to a different location in the wellbore where the anchor 200 may be again deployed.

15 [0021] In another embodiment, the anchor may be adapted to serve as a mechanism for downhole conveyance or “tractoring.” In this embodiment, the operation of the rotatable hub 204, deployment linkages 206, and slips 210 is generally as described in connection with FIGS 1 – 3, however, the deployment linkages 206 are arranged to deploy at an angle, rather than a single plane that is normal to the central axis. This embodiment is depicted in FIG. 4. The deployment linkages 206 are deployed at an angle and initially meet the casing at an angle θ , rather than a normal to the central axis. At this point housing 214 is located in in the wellbore as indicated by the dotted lines. As rotatable hub 204 is further rotated, deployment linkages 206 are further extended and the resulting force against wellbore 202 causes the anchor, and any downhole tools, to be driven, or “tractored,” linearly along the wellbore until the deployment linkages 206 are fully extended and reach the position shown in the solid lines in FIG. 4. This operation may be repeated allowing the anchor to serve as a conveyance mechanism.

25 [0022] In another embodiment, the anchor 200, particularly the rotatable hub 204, may be arranged to accommodate different lengths of the deployment linkages to assist in allowing the downhole anchoring apparatus to be deployed in different size downhole casings. The deployment linkages 206 may be field-replaceable to allow the anchor 200 to be customized for different sized wellbore casing quickly and easily.

[0023] In a further embodiment of the disclosure, there is provided a downhole anchoring apparatus for use in a downhole tool. The downhole anchoring apparatus includes a housing with a rotatable hub provided within the housing. The rotatable hub may be arranged to rotate in a bi-directional fashion about a longitudinal axis. The downhole anchoring apparatus also includes a deployment linkage. The deployment linkage may be coupled to the rotatable hub by a hinge. When the rotatable hub is rotated in a first direction, a distal end of the deployment linkage is extended radially outward from the central axis. When the rotatable hub is rotated in a second direction, the distal end of the deployment linkage is retracted toward the central axis.

[0024] The downhole apparatus also includes a slip. The slip may be coupled to the distal end of the deployment linkage. Radial extension of the deployment linkage causes the slip to engage an inner surface of the wellbore casing. Retraction of the deployment linkage causes the slip to disengage the inner surface of the wellbore casing.

[0025] In some embodiments, the system may further comprise any one of the following features individually or any two or more of these features in combination: (a) a plurality of deployment linkages arranged on the rotatable hub so that the downhole anchoring apparatus self-centers in the wellbore casing when the slips engage the inner surface of the wellbore casing; (b) the rotatable hub arranged to accommodate different lengths of the deployment linkages so the downhole anchoring apparatus may be deployed in different size downhole casings; (c) the hinge coupling the rotatable hub to the deployment linkage includes a hinge seat so that when the slip engages the inner surface of the wellbore casing the compressive force in the deployment linkage is transferred to the hinge seat; (d) the housing including an opening or recess to accommodate the slip, so that when the deployment linkage is retracted, the slip is generally flush with the outer surface of the housing; (e) a guide to limit the non-radial movement of the deployment linkage, which may be, for example, a slot or channel, which may be allowed to pivot, or rollers or other bearings; and (f) the deployment linkage extends at an angle away from normal to the central axis.

[0026] In another embodiment of the disclosure provides a method for anchoring a downhole tool. In this embodiment, the method includes positioning a housing having a rotatable hub into a section of wellbore casing, in which the rotatable hub is arranged to bi-directionally rotate about a longitudinal axis. Rotating the rotatable hub in a first direction extends a deployment linkage radially outward from a central axis. The

deployment linkage has a slip coupled to a distal end. The slip engages an inner surface of the wellbore casing when the rotatable hub is rotated in a first direction. The slip is disengaged from the inner surface of the wellbore casing when the rotatable hub is rotated in a second direction.

5 [0027] In some embodiments, the method may further comprise any one of the following features individually or any two or more of these features in combination: (a) further extending a plurality of deployment linkages when the rotatable hub is rotated so that the downhole anchoring apparatus self-centers in the wellbore casing when the slips engage the inner surface of the wellbore casing; (b) adjusting the lengths of the
10 deployment linkages so that the downhole anchoring apparatus may be deployed in different size downhole casings; (c) transferring the compressive force in the deployment linkage when the slips are engaged with the wellbore casing to a hinge seat arranged on the rotatable hub; (d) retracting the deployment linkage into an opening or recess on the housing so that the slip is generally flush with the outer surface of the housing; (e)
15 moving the deployment linkage through a guide that limits the non-radial movement of the deployment linkage, which may be, for example, a slot or channel, which may be allowed to pivot, or rollers or other bearings; (f) extending a plurality of deployment linkages in a manner to tractor a downhole tool along the wellbore casing; and (g) the deployment linkages extend at an angle away from normal to the central axis so that they
20 can move the downhole tool along a longitudinal axis in the wellbore.

[0028] In still a further embodiment, a system for anchoring a downhole tool in a section of wellbore casing is provided. The system includes a downhole tool for performing an operation in the wellbore and an anchor having rotatable hub in the housing. The rotatable hub is bi-directionally rotatable about a central axis. A
25 deployment linkage is coupled to the rotatable hub by a hinge. When the rotatable hub is rotated in a first direction, a distal end of the deployment linkage is extended radially outward from the central axis. When the rotatable hub is rotated in a second direction, the distal end of the deployment linkage is retracted toward the central axis. The system also includes a slip coupled to the distal end of the deployment linkage, which engages an
30 inner surface of the wellbore casing when the deployment linkage is extended, and which disengages the inner surface of the wellbore casing when the deployment linkage is retracted.

[0029] In some embodiments, the system may further comprise any one of the following features individually or any two or more of these features in combination: (a) a plurality of deployment linkages arranged on the rotatable hub so that the anchor self-centers in the wellbore casing when the slips engage the inner surface of the wellbore casing; (b) the rotatable hub arranged to accommodate different lengths of the deployment linkages so the anchor may be deployed in different size downhole casings; (c) the hinge coupling the rotatable hub to the deployment linkage comprises a hinge seat so that when the slip engages the inner surface of the wellbore casing the compressive force in the deployment linkage is transferred to the hinge seat; (d) the housing comprises an opening or recess to accommodate the slip, so that when the deployment linkage is retracted, the slip is generally flush with the outer surface of the housing; (e) a guide to limit the non-radial movement of the deployment linkage, which may be, for example, a slot or channel, which may be allowed to pivot, or rollers or other bearings; and (f) the deployment linkages extend at an angle away from normal to the central axis.

[0030] While the disclosed embodiments have been described with reference to one or more particular implementations, those skilled in the art will recognize that many changes may be made thereto without departing from the spirit and scope of the description. Accordingly, each of these embodiments and obvious variations thereof is contemplated as falling within the spirit and scope of the following claims.

CLAIMS

What is claimed is:

1. A downhole anchoring apparatus for use in a downhole tool, the downhole anchoring apparatus comprising:
 - 5 a housing;
 - a hub rotatably arranged on a longitudinal axis in the housing;
 - a deployment linkage coupled to the hub by a hinge so that a distal end of the deployment linkage extends radially outward from the longitudinal axis as the hub is rotated in a first direction and radially retracts toward the longitudinal axis as
10 the hub is rotated in a second direction;
 - a slip coupled to the distal end of the deployment linkage that engages an inner surface of the wellbore casing in response to radial extension of the deployment linkage and disengages the inner surface of the wellbore in response to retraction of the deployment linkage.
- 15 2. A downhole anchoring apparatus according to claim 1, further comprising a plurality of deployment linkages arranged on the hub so that the downhole anchoring apparatus self-centers in the wellbore casing when the slips engage the inner surface of the wellbore casing.
- 20 3. A downhole anchoring apparatus according to claim 2, wherein the hub is arranged to accommodate different lengths of the deployment linkages so the downhole anchoring apparatus may be deployed in different size downhole casings.
4. A downhole anchoring apparatus according to claim 1, wherein the hinge coupling the hub to the deployment linkage comprises a hinge seat.
- 25 5. A downhole anchoring apparatus according to claim 1, wherein the housing comprises an opening or recess that receives the retracted slip so it is flush with the outer surface of the housing.

6. A downhole anchoring apparatus according to claim 1, further comprising a guide that limits the non-radial movement of the deployment linkage.
7. A downhole anchoring apparatus according to claim 6, wherein the guide comprises a channel, a slot, or a roller that pivots relative to the angle of the deployment linkage.
5
8. A downhole anchoring apparatus according to claim 1, wherein the deployment linkage extends at an angle away from a normal to the longitudinal axis.
9. A method for anchoring a downhole tool, the method comprising:
positioning a housing having a hub arranged to bi-directionally rotate about a longitudinal axis of the downhole tool into a section of wellbore casing;
10
rotating the hub in a first direction to extend a deployment linkage radially outward from the longitudinal axis, the deployment linkage having a slip coupled to a distal end of the deployment linkage, wherein the slip engages an inner surface of the wellbore casing when the hub is rotated in the first direction; and
15
wherein the slip is disengaged from the inner surface of the wellbore casing when the hub is rotated in a second direction.
10. A method according to claim 10, further comprising extending a plurality of deployment linkages when the hub is rotated so that the downhole anchoring apparatus self-centers in the wellbore casing when the slips engage the inner surface of the wellbore casing.
20
11. A method according to claim 11, further comprising adjusting the lengths of the deployment linkages so that the downhole anchoring apparatus may be deployed in different size downhole casings.
12. A method according to claim 10, further comprising retracting the deployment linkage into an opening or recess on the housing so that the slip is generally flush with the outer surface of the housing.
25

13. A method according to claim 10, further comprising moving the deployment linkage through a guide that limits the non-radial movement of the deployment linkage.
14. A method according to claim 8, further comprising extending the deployment linkages at an angle away from a normal to the central axis to move the downhole tool along a longitudinal axis in the wellbore.
15. A system for anchoring a downhole tool in a section of wellbore casing, the system comprising:
a downhole tool for performing an operation in the wellbore;
an anchor having a bidirectionally rotatable hub arranged on a longitudinal axis of a housing;
a deployment linkage connected to the hub by a hinge, wherein when the hub is rotated in a first direction, a distal end of the deployment linkage is extended radially outward from the longitudinal axis, and when the hub is rotated in a second direction the distal end of the deployment linkage is retracted toward the longitudinal axis;
a slip coupled to the distal end of the deployment linkage, which engages an inner surface of the wellbore casing when the deployment linkage is extended, and which disengages the inner surface of the wellbore casing when the deployment linkage is retracted.
16. A system according to claim 20, further comprising a plurality of deployment linkages arranged on the hub so that the anchor self-centers in the wellbore casing when the slips engage the inner surface of the wellbore casing.
17. A system according to claim 21, wherein the hub is arranged to accommodate different lengths of the deployment linkages so the anchor may be deployed in different size downhole casings.
18. A system according to claim 20, further comprising a channel, a slot or a roller that limits the non-radial movement of the deployment linkage.

19. A system according to claim 25, wherein the guide comprises a pivot.
20. A system according to claim 20, further wherein the deployment linkages extend at an angle away from a normal to the longitudinal axis.

FIG.1

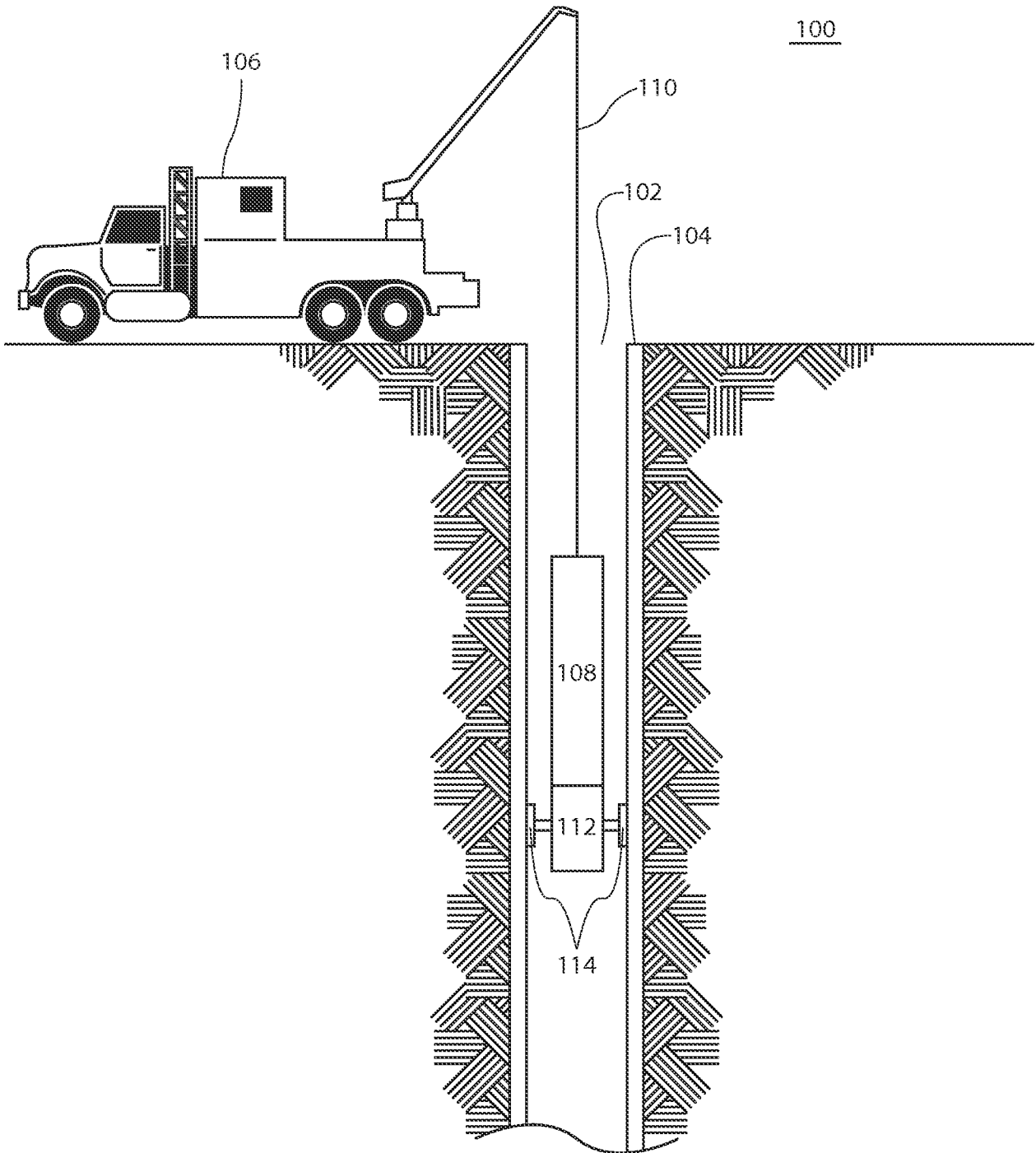

FIG.2

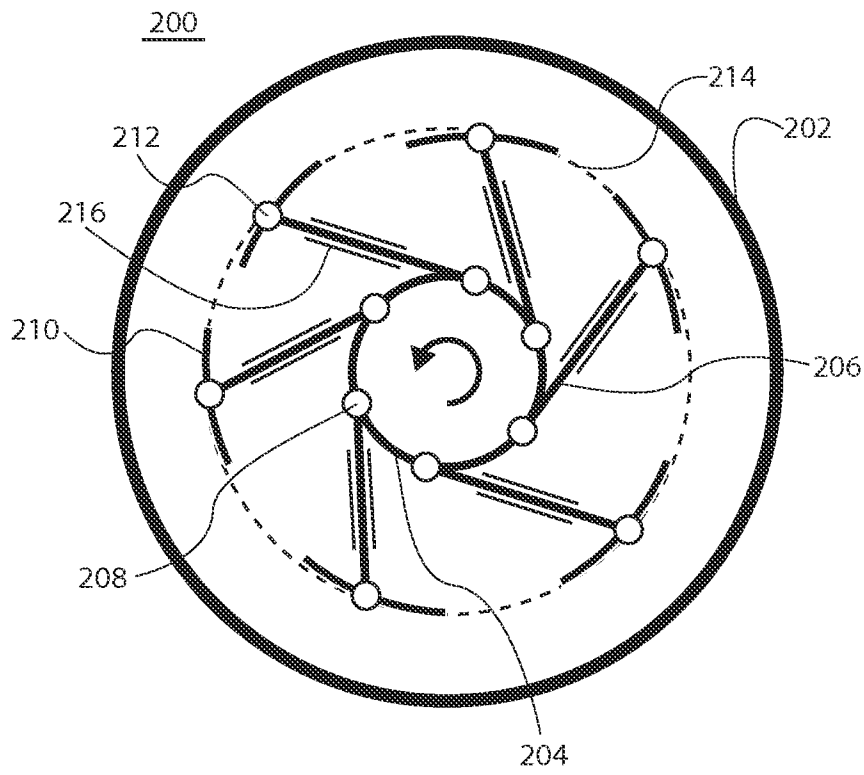

FIG.3

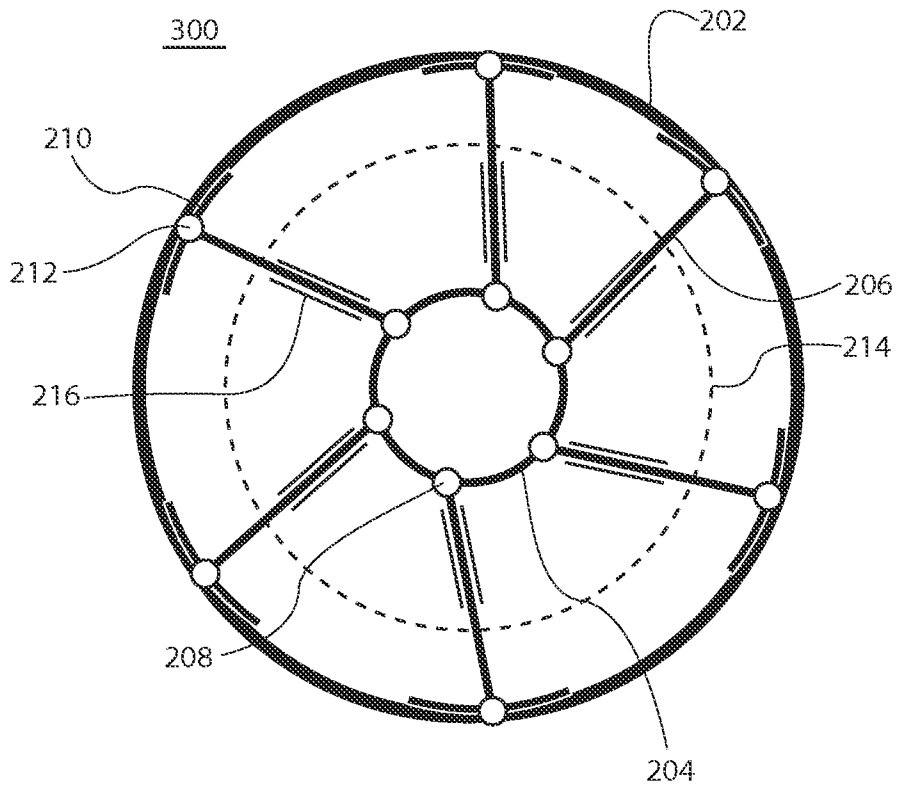
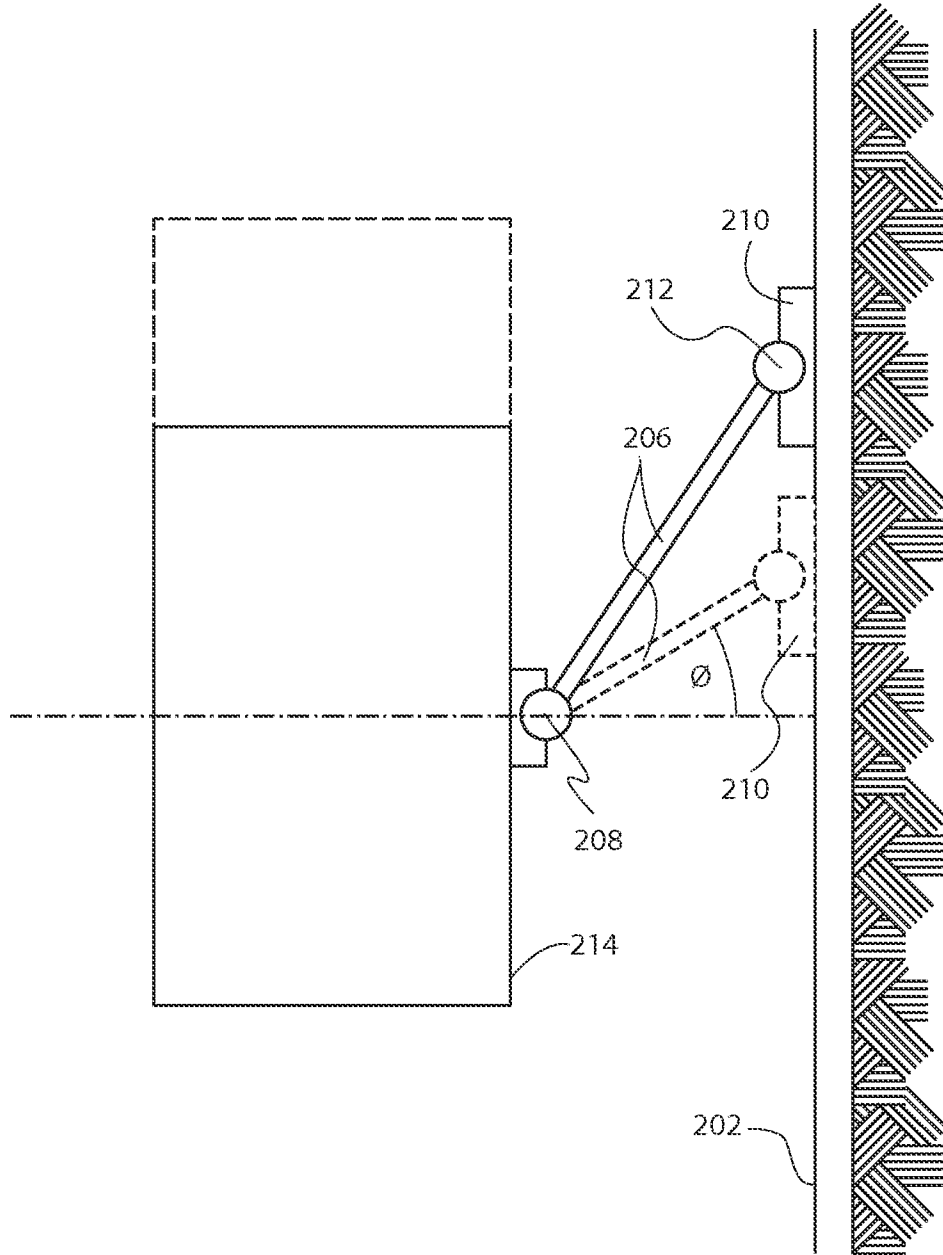

FIG.4



INTERNATIONAL SEARCH REPORT

International application No.
PCT/US2014/037007**A. CLASSIFICATION OF SUBJECT MATTER****E21B 23/01(2006.01)i, E21B 33/10(2006.01)i**

According to International Patent Classification (IPC) or to both national classification and IPC

B. FIELDS SEARCHEDMinimum documentation searched (classification system followed by classification symbols)
E21B 23/01; B25B 15/00; E21B 23/00; E21B 29/00; E21B 33/129; E21B 33/10Documentation searched other than minimum documentation to the extent that such documents are included in the fields searched
Korean utility models and applications for utility models
Japanese utility models and applications for utility modelsElectronic data base consulted during the international search (name of data base and, where practicable, search terms used)
eKOMPASS(KIPO internal) & keywords: downhole tool, anchor, housing, hub, deployment linkage, slip, hinge, and guide**C. DOCUMENTS CONSIDERED TO BE RELEVANT**

Category*	Citation of document, with indication, where appropriate, of the relevant passages	Relevant to claim No.
Y	US 4499799 A (BORDAGES, JOHN W.) 19 February 1985 See column 2, line 28 - column 3, line 25 and figures 1-4.	1-20
Y	US 2009-0071659 A1 (SPENCER et al.) 19 March 2009 See paragraphs [0021], [0023]-[0024] and figures 1-3.	1-20
A	US 2005-0263280 A1 (SELLERS et al.) 01 December 2005 See paragraphs [0045]-[0048] and figures 1-2.	1-20
A	US 4811785 A (WEBER, JAMES L.) 14 March 1989 See column 5, line 16 - column 6, line 37 and figures 4-6.	1-20
A	US 6311778 B1 (CARISELLA et al.) 06 November 2001 See column 3, line 43 - column 4, line 7 and figure 3.	1-20

 Further documents are listed in the continuation of Box C. See patent family annex.

* Special categories of cited documents:

"A" document defining the general state of the art which is not considered to be of particular relevance

"E" earlier application or patent but published on or after the international filing date

"L" document which may throw doubts on priority claim(s) or which is cited to establish the publication date of another citation or other special reason (as specified)

"O" document referring to an oral disclosure, use, exhibition or other means

"P" document published prior to the international filing date but later than the priority date claimed

"T" later document published after the international filing date or priority date and not in conflict with the application but cited to understand the principle or theory underlying the invention

"X" document of particular relevance; the claimed invention cannot be considered novel or cannot be considered to involve an inventive step when the document is taken alone

"Y" document of particular relevance; the claimed invention cannot be considered to involve an inventive step when the document is combined with one or more other such documents, such combination being obvious to a person skilled in the art

"&" document member of the same patent family

Date of the actual completion of the international search

05 February 2015 (05.02.2015)

Date of mailing of the international search report

05 February 2015 (05.02.2015)

Name and mailing address of the ISA/KR

 International Application Division
 Korean Intellectual Property Office
 189 Cheongsa-ro, Seo-gu, Daejeon Metropolitan City, 302-701,
 Republic of Korea

Facsimile No. ++82 42 472 3473

Authorized officer

PARK, Tae Wook

Telephone No. +82-42-481-3405



INTERNATIONAL SEARCH REPORT

Information on patent family members

International application No.

PCT/US2014/037007

Patent document cited in search report	Publication date	Patent family member(s)	Publication date
US 4499799 A	19/02/1985	None	
US 2009-0071659 A1	19/03/2009	AU 2008-300246 A1 AU 2008-300246 B2 CA 2699895 A1 DK 2205818 T3 EP 2205818 A1 EP 2205818 B1 MX 2010002939 A RU 2010115279 A RU 2467152 C2 US 7886834 B2 WO 2009-037657 A1	26/03/2009 20/12/2012 26/03/2009 07/01/2013 14/07/2010 05/12/2012 21/04/2010 27/10/2011 20/11/2012 15/02/2011 26/03/2009
US 2005-0263280 A1	01/12/2005	US 7252143 B2	07/08/2007
US 4811785 A	14/03/1989	US 4901793 A	20/02/1990
US 6311778 B1	06/11/2001	None	