



(12) EUROPEAN PATENT APPLICATION

(43) Date of publication:
27.09.2006 Bulletin 2006/39

(51) Int Cl.:
B65B 29/02 (2006.01) B65B 9/04 (2006.01)

(21) Application number: 05076557.7

(22) Date of filing: 08.07.2005

(84) Designated Contracting States:
AT BE BG CH CY CZ DE DK EE ES FI FR GB GR
HU IE IS IT LI LT LU LV MC NL PL PT RO SE SI
SK TR
Designated Extension States:
AL BA HR MK YU

(72) Inventor: Binacchi, Fabio,
Opem S.R.L.
43100 Parma (IT)

(74) Representative: Corradini, Corrado et al
Studio Ing. C. CORRADINI & C. S.r.l.
4, Via Dante Alighieri
42100 Reggio Emilia (IT)

(30) Priority: 22.03.2005 IT RE20050027

(71) Applicant: Opem s.r.l.
43100 Parma (IT)

(54) Plant and method for the continuous manufacture of brewing cartridges

(57) A plant (1a, 1b) for the manufacture of brewing cartridges comprising: guide means (4) for guiding plates (2) having recesses (3) along an advancing direction; means (7) for providing, above the plates (2), a first band (6) of film that; means (21) for depositing a dose of powder through a metering device (9, 12) for each recess (3); means (14) for pressing the doses of powder in the recesses (3); means (19) for providing, over the pressed doses, a second band (17) of film; sealing means (15) for sealing said first (6) and second band (17) together

forming the cartridges (100); cutting means (16) to cut the formed cartridges (100), where said cartridges (100) are manufactured whilst the guide means (4) make the plates (2) advance at a constant speed and where said depositing means (21), said pressing means (14), said means (7, 19) for providing said first and second band (6, 17), said sealing means (15) and said cutting means (16) are actuated in synchrony with said plates (2), to operate continuously along a horizontal manufacturing plane.

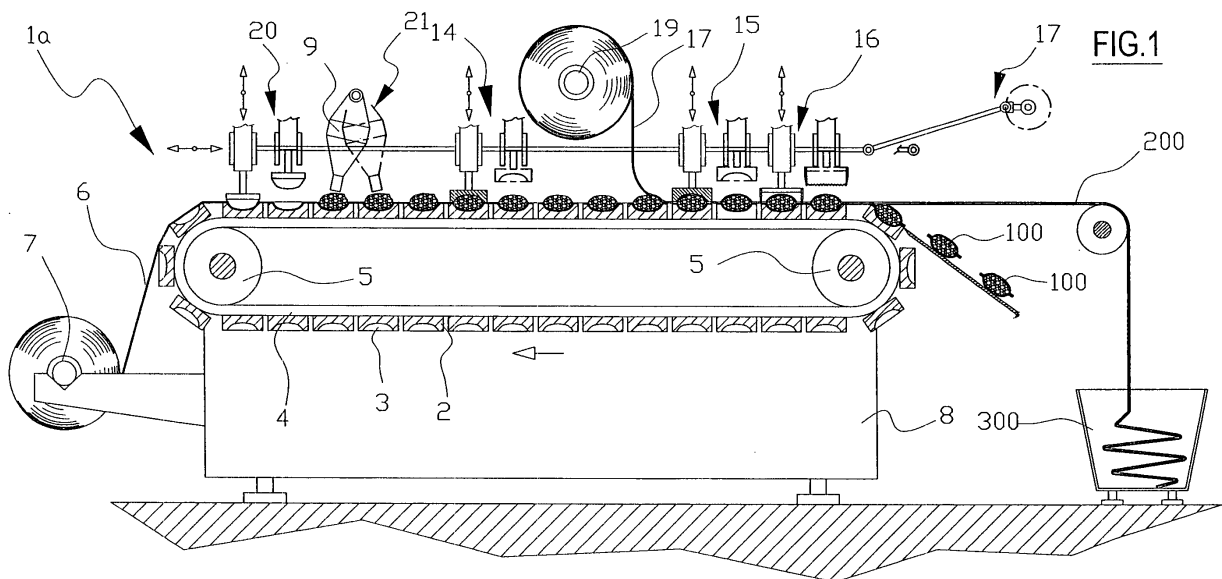

Description

[0001] The present finding refers to a plant and method for the continuous manufacture of brewing cartridges.

[0002] More specifically, the present invention refers to a plant and method for the continuous manufacture of espresso or American coffee cartridges.

[0003] As known, plants for the manufacture of coffee cartridges generally consist of a chain made to advance step by step and supporting a plurality of plates that are equally spaced apart along the same chain, where each plate is provided with a plurality of recesses.

[0004] In patent EP0780307 to the same Applicant a plant is shown, in which the following are arranged along the direction followed by the chain: means for providing, above the plates, a first continuous band of permeable film that covers each recess; means for depositing a dose of coffee powder on top of the first band at each recess, through an autonomous metering device for each recess; means for pressing the doses of coffee powder deposited in the recesses; means for providing, over the pressed doses, a second band of permeable film; sealing means for sealing the first and second band together with the doses of pressed powder inside, forming the cartridges; cutting means to cut the formed cartridges.

[0005] Plants of the aforementioned type do, nevertheless, have some drawbacks.

[0006] Indeed, due to the step by step moving system, the production yield of the cartridges is rather low, and moreover such plants require continuous and constant maintenance above all considering the type of movement carried out.

[0007] Plants for manufacturing coffee cartridges that operate with a continuous movement and capable of high yields of cartridges are also known.

[0008] Said continuous plants generally consist of a rotatable released drum along which the recesses for the deposition of coffee powder are formed. In these plants the powder is fed through a scraping metering device of simple construction.

[0009] Unfortunately, these continuous plants of the prior art have substantial drawbacks since the cartridges produced with them have substantially different weights unlike what is usually desired.

[0010] Moreover, downstream of the scraping metering device a powdery zone is created that causes incrustations and long machine idle times for cleaning and re-setting the plant. Overall, these continuous plants are somewhat complicated and need continuous maintenance. Moreover, the cartridges manufactured with these plants have undesired depressions and/or swelling, as well as the presence of coffee powder in the sealing points.

[0011] Therefore, there is a great need to have a plant for the manufacture of brewing cartridges that has high production yields whilst respecting the quality of the finished product through the production of cartridges all having substantially the same weight and configured to

be used optimally in the brewing apparatuses currently on the market.

[0012] The purpose of the present invention is that of providing a method and plant for the manufacture of brewing cartridges having structural and functional characteristics such as to satisfy the aforementioned requirements and at the same time to avoid the aforementioned drawbacks with reference to the prior art. Such a purpose is accomplished through a plant for the manufacture of brewing cartridges in accordance with claim 1 and a method according to claim 11.

[0013] The dependent claims outline preferred and particularly advantageous embodiments of the plant according to the invention.

[0014] Further characteristics and advantages of the invention shall become clear from reading the following description provided as an example and not for limiting purposes, with the help of the figures illustrated in the attached tables, in which:

- figure 1 shows a schematic side view partially in section of a plant for the manufacture of brewing cartridges according to the present invention, in accordance with a first embodiment;
- figure 2 shows a perspective view of a detail of the possible plates that can be used in the plant of figure 1;
- figure 3 shows a schematic side view partially in section of a plant for the manufacture of brewing cartridges according to the present invention, in accordance with a second embodiment;
- figure 4 shows a detail in section of the cartridge, during the sealing step.

[0015] With reference to the aforementioned figures, the plant for the manufacture of brewing cartridges, in accordance with the present invention, which is globally indicated, in the two embodiments, through the reference numerals 1a and 1b respectively, comprises guide means for guiding a plurality of plates 2 along an advancing direction.

[0016] Each plate 2 is provided, on the upper part of the surface, with a plurality of recesses 3 arranged transversally with respect to the advancing direction.

[0017] As illustrated in figure 2, the amount of recesses 3 present on the plates 2 can vary according to the production requirements.

[0018] The guide means for guiding the plates 2 comprise a motorised closed chain 4 on a pair of opposite rollers or pinions 5 having the respective parallel and horizontal rotation axes.

[0019] In the example, said chain consists of a pair of parallel, flexible and inextensible catenaries 4', 4" (fig. 2).

[0020] At least one of the rollers or pinions 5 is actuated, with a continuous movement at constant speed, with respect to its own axis, so as to make the plates 2 advance at a constant speed to arrange them in succession at the manufacturing steps of the cartridges 100.

[0021] As shown in figures 1 and 3, the plates 2 are fixed to the chain 4 and are uniformly spaced apart.

[0022] More specifically, the plant comprises means for providing, above the plates 2, a first continuous band 6 of permeable film that covers each recess 3. In the example, the first band 6 is wound on an unwinding roller 7 rotatably associated with a base 8 upon which the pair of rollers or pinions 5 also depend.

[0023] The width of the first band 6 is such as to allow all of the recesses 3 present on each plate 2 to be substantially covered.

[0024] The plant also comprises means 21 for depositing a dose of brewing powder, for example coffee powder, at each recess 3 through an autonomous metering device 9 for each recess 3, above the first band 6.

[0025] In order to obtain an accurate dosage, said means 21 for depositing a dose of brewing powder are managed with feedback through weight control system, not illustrated, of the dose of powder arranged downstream of the plant.

[0026] In the first embodiment, illustrated in figure 1, said metering devices 9 undergo an oscillating movement with respect to an oscillation axis transversal to the advancing direction.

[0027] Basically, the metering devices 9 deposit a desired amount of powder for each recess 3 during the advancing of the underlying plates 2, and therefore the speed in the advancing direction is the same.

[0028] For said metering devices 9, the magnitude of oscillation carried out for the depositing of powder and the speed of the oscillation in the opposite direction to the advancing direction are chosen so as to ensure the correct filling of the recesses 3 with a predetermined dose of powder and they can be chosen according to multiple alternatives that always ensure synchrony with the plates 2 in the advancing direction.

[0029] Alternatively, it is possible to foresee a pilgrim process, not illustrated, for said metering devices 9.

[0030] In the second embodiment, illustrated in figure 3, the means 21 for depositing a dose of brewing powder comprise a charging hopper 10 of the brewing powders associated with a drum 1 rotating at the same speed as the plates 2 and provided with undercuts 12 that selectively interface with the corresponding recesses 3 during the rotation of the drum 11 for the release of a dose of brewing powder for each recess 3.

[0031] Basically, the undercuts 12 have the same function as the metering devices 9 of figure 1.

[0032] In order to avoid the powder loaded in the undercuts 12 falling, it is foreseen to use a suitable cylinder arc-shaped sealing element 13 cooperating with the semicircle involved, in the illustrated example arranged on the left.

[0033] Said sealing element 13 can also have the functions of a cleaner of the drum portions 11 surrounding the undercuts 12. In addition, it is possible to foresee the use of further cleaning means, not illustrated.

[0034] Upstream of the metering devices 9 means 14

for pressing the doses of brewing powder deposited in the recesses 3, sealing means 15 and cutting means 16 are installed in succession, which in the first example are actuated through a pilgrim process and in the second embodiment are actuated into rotation about an axis for each one, transversal to the advancing direction of the plates 2.

[0035] The pilgrim process allows alternating up and down movement, along a vertical line, indicated with the vertical double arrows in figure 1, and simultaneous advancing along a horizontal line, indicated with the horizontal double arrow in figure 1.

[0036] However, it is possible to use the aforementioned two moving systems according to whatever combination.

[0037] In the first embodiment (fig. 1) all of the means moved with the pilgrim process are preferably actuated by a single actuator, schematised in the crank mechanism indicated with 17 in figure 1, which moves them simultaneously on a plane horizontal plane parallel to the advancing direction.

[0038] In the second embodiment (fig. 3), the pressing means 14 and the cutting means 16 consist of a turntable system, whereas the sealing means 15 consist of a rotating drum provided with cavities having the outline suitable for welding.

[0039] Of course, upstream of the sealing means 15 means are foreseen that deposit, over the pressed doses, a second band 18 of permeable film, using, for example, a further unwinding roller 19.

[0040] Moreover, it is preferable to use preforming means 20 of the first band 6 at the recesses 3 before they are filled with the brewing powder.

[0041] Said performing means 20, in the first embodiment, have alternating movement along a vertical line towards the recesses 3 coordinated by the actuator 17 along a horizontal line parallel to the advancing direction, with a pilgrim process movement.

[0042] In the second embodiment, said performing means 20 are actuated into rotation about a horizontal axis transversal to the advancing direction.

[0043] This allows the first band 6 to be distributed by making it exactly couple with the plurality of recesses 3 present on the plates 2, proportionally and delicately covering its whole surface and accurately avoiding the first band 6 fraying.

[0044] In accordance with the present invention, the performing means 20, the metering devices 9, the pressing means 14, the unwinding rollers 7, 19, the sealing means 15 and the cutting means 16 are all actuated in synchrony with the plates 2 that advance at a constant speed, to operate continuously along a horizontal manufacturing plane of the cartridges 100.

[0045] Operatively, the first band 6 is laid on the plates 2 in movement at constant speed.

[0046] In succession, the following act: the performing means 20 of said first band 6 at the recesses 3; the metering devices 9 that deposit the dose of brewing powder

in each recess 3; the means 14 for pressing the powder deposited in the recesses 3; the means for providing the second band 18 over the first band 6; the sealing means 15 that seal the two bands 6, 18 together to form the cartridges 100; the cutting means 16 for punching the outlines of the cartridges directly on the plates 2.

[0047] At the end of the manufacture of the cartridges 100, the waste 200 of the bands 6, 18 is separated from the cartridges 100. In the example, the waste 200 is directed into a suitable container 300, whereas the cartridges 100 are made to slide into a collection sector, not illustrated.

[0048] As stated previously, the cartridges 100 are manufactured continuously along a horizontal manufacturing plane on which the plates 2 are made to advance at a constant speed.

[0049] As can be appreciated from what has been described, the plant for the manufacture of brewing cartridges according to the present invention allows the requirements to be satisfied and the drawbacks mentioned in the introductory part of the present description with reference to the prior art to be overcome.

[0050] Indeed, since the manufacturing cycle takes place continuously on a horizontal plane, the plant for the manufacture of brewing cartridges according to the invention ensures better forming of the cartridges without spilling product outside of the outer edge constituting an advantage for the quality of the end product.

[0051] Moreover, with the plant of the present invention cartridges of equal weight are obtained during the entire production cycle and with the opposite surfaces regular, i.e. without undesired swelling and/or depressions also thanks to the cut carried out directly on the manufacturing plane.

[0052] Furthermore, said plant allows perfect and clean welds to be obtained in the sealing points of the bands forming the cartridges, in a zone without powder residues.

[0053] Also of note is the long operating time without interruptions that the plant according to the present invention allows to be achieved thanks to the simple continuous moving system that avoids the work stress typical of alternating movement plants.

[0054] Of course, a man skilled in the art can bring numerous modifications and variants to the plant for the manufacture of brewing cartridges described above in order to satisfy contingent and specific requirements, all of which are in any case covered by the scope of protection of the invention, as defined by the following claims.

Claims

1. Plant (1a, 1b) for the manufacture of brewing cartridges comprising:

- guide means (4) for guiding a plurality of plates (2) along an advancing direction, each plate (2)

being provided with a plurality of recesses (3) arranged transversally with respect to said advancing direction;

- means (7) for providing, above the plates (2), a first continuous band (6) of permeable film that covers each recess (3);

- means (21) for depositing a dose of brewing powder at each recess through an autonomous metering device (9, 12) for each recess (3), over said first band (6);

- means (14) for pressing the doses of brewing powder deposited in the recesses (3);

- means (19) for providing, over the pressed doses, a second band (17) of permeable film;

- sealing means (15) for sealing said first (6) and second band (17) together with the doses of pressed powder inside, forming the cartridges (100);

- cutting means (16) to cut the formed cartridges (100),

characterised in that said cartridges (100) are manufactured whilst the guide means (4) make the plates (2) advance at a constant speed and **in that** said depositing means (21), said pressing means (14), said means (7, 19) for providing said first and second band (6, 17), said sealing means (15) and said cutting means (16) are actuated in synchrony with said plates (2), to operate continuously along a horizontal manufacturing plane.

2. Plant according to claim 1, wherein said guide means comprise a motorised closed chain (4) on a pair of opposite rollers (5) having the respective parallel and horizontal rotation axes.

3. Plant according to claim 2, wherein said chain (4) consists of a pair of parallel, flexible and inextensible catenaries (4', 4'').

4. Plant according to claim 3, wherein said plates (2) are associated with the pair of catenaries (4', 4'') in an equidistant manner.

5. Plant according to claim 1, wherein said means (21) for depositing a dose of brewing powders are managed with feedback through a weight control system of the dose of the powders arranged downstream of the plant.

6. Plant according to claim 1, wherein said metering devices (9) are moved through a pilgrim process.

7. Plant according to claim 1, wherein said metering devices (9) have an oscillating movement with respect to an oscillation axis transversal to the advancing direction of the plates (2).

8. Plant according to claim 1, wherein said means (21) for depositing a dose of brewing powder comprise a charging hopper (10) of the brewing powders associated with a drum (11) rotating at the same speed as the plates (2) and provided with undercuts (12) that selectively interface with the corresponding recesses (3) during the rotation of the drum (11) for releasing a dose of brewing powder for each recess (3).
5
10
9. Plant according to claim 1, wherein said pressing means (14), said sealing means (15) and said cutting means (16) are actuated through a moving system selected from rotation about a respective axis, transversal to the advancing direction of the plates (2) and pilgrim process.
15
10. Plant according to claim 1, further comprising performing means (20) of said first band (6) at the recesses (3) before they are filled with brewing powders.
20
11. Method for the manufacture of brewing cartridges comprising the steps of:
25
- guiding a plurality of plates (2) along a advancing direction, each plate (2) being provided with a plurality of recesses (3) arranged transversally with respect to said advancing direction;
 - providing, over the plates (2), a first continuous band (6) of permeable film that covers each recess (3);
30
 - depositing a dose of brewing powder at each recess (3) through an autonomous metering device (9, 12) for each recess (3), above said first band (6);
35
 - pressing the doses of brewing powder deposited in the recesses (3);
 - providing, over the pressed doses, a second band (17) of permeable film;
40
 - sealing said first and second band (6, 17) together with the doses of pressed powder inside forming the cartridges (100);
 - cutting the formed cartridges (100),
45
- characterised in that** said cartridges (100) are manufactured continuously along a horizontal manufacturing plane on which said plates (2) are made to advance at a constant speed.
50
12. Method according to claim 11, wherein said step of cutting the cartridges (100) is carried out directly on the plates (2) whilst they advance horizontally at constant speed.
55

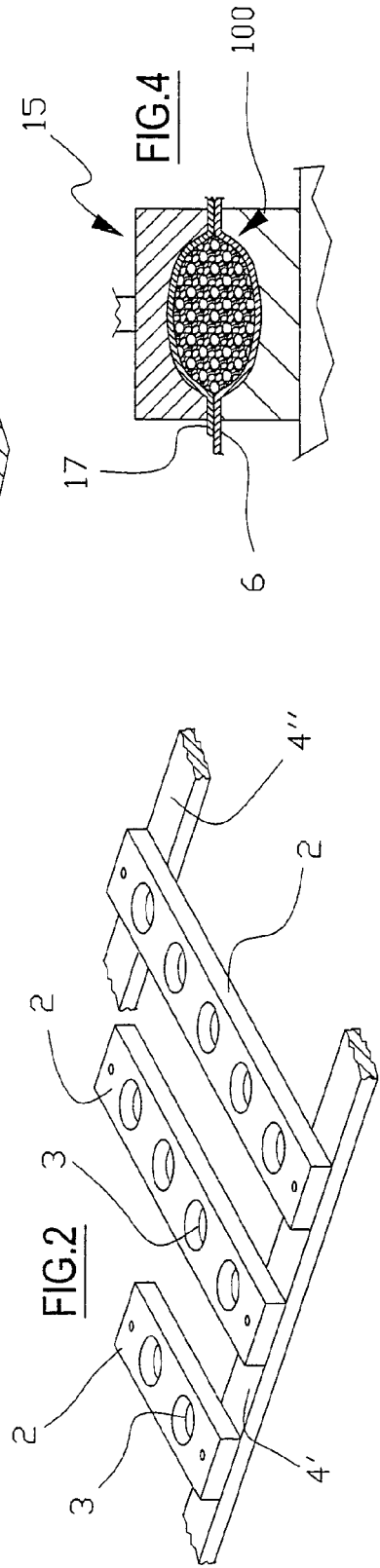
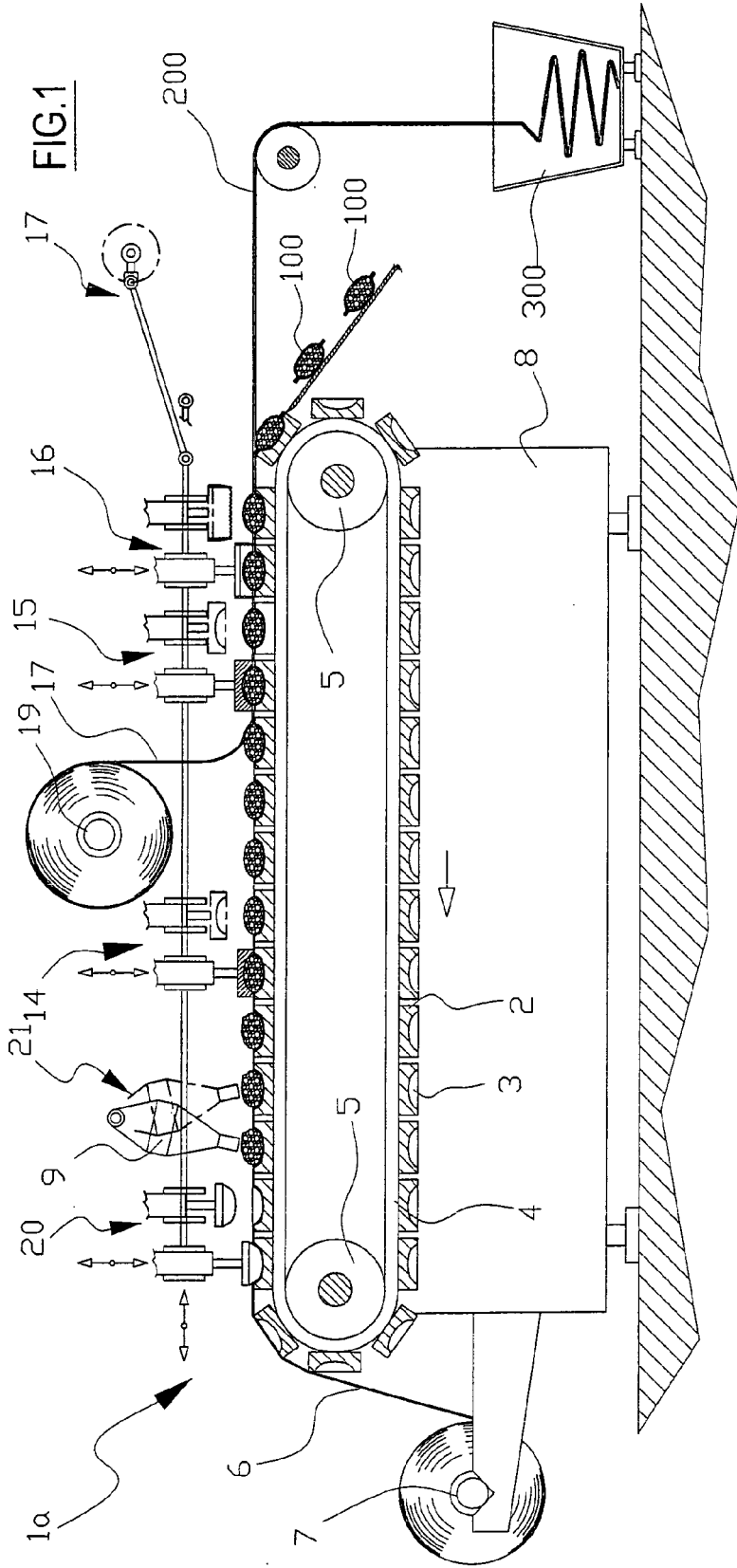

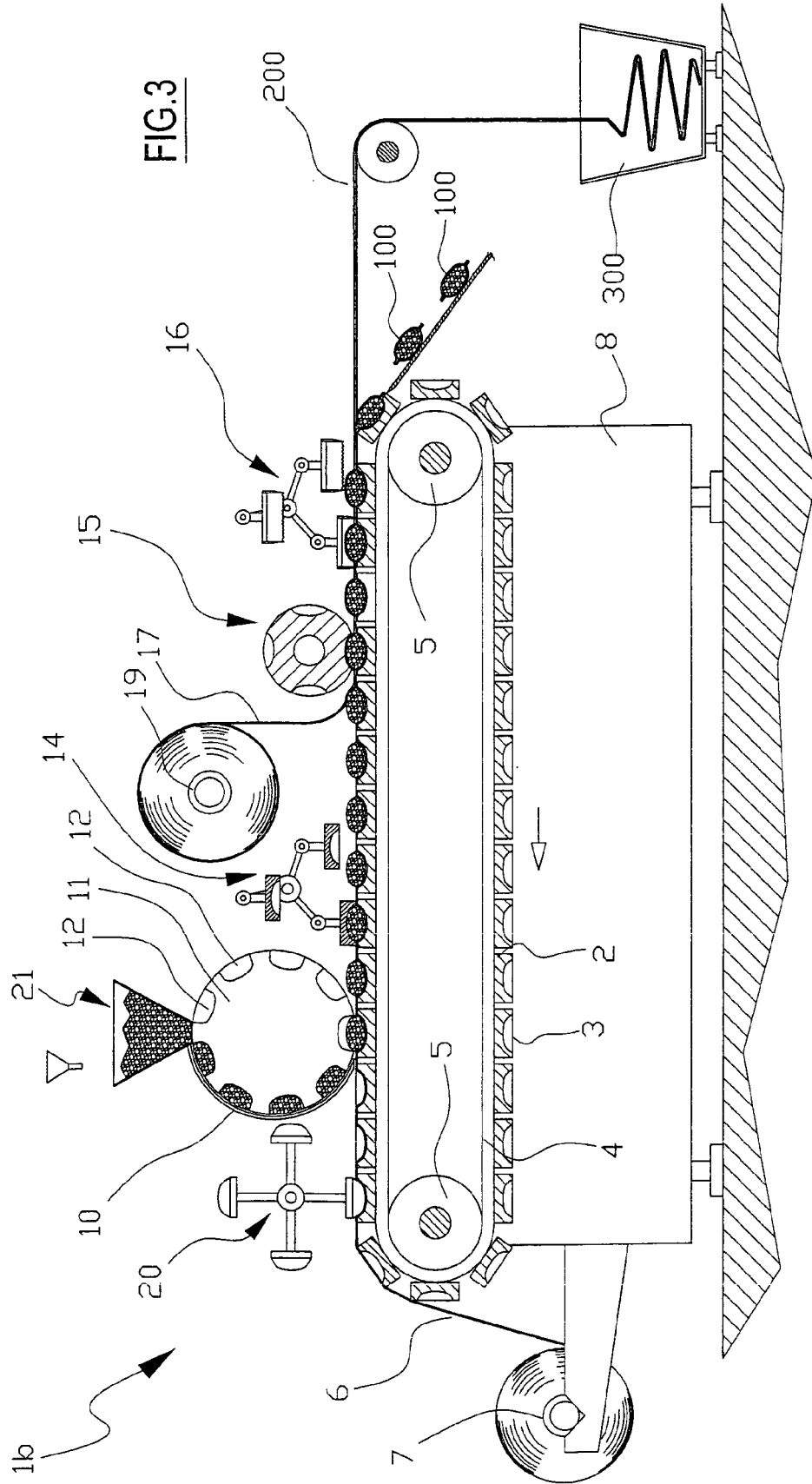



DOCUMENTS CONSIDERED TO BE RELEVANT			
Category	Citation of document with indication, where appropriate, of relevant passages	Relevant to claim	CLASSIFICATION OF THE APPLICATION (IPC)
X	US 5 074 102 A (SIMPSON ET AL) 24 December 1991 (1991-12-24) * column 3, line 56 - line 61; figures 1-15 *	1-4,8, 10-12	INV. B65B29/02 B65B9/04
X	FR 1 172 697 A (REINHARDT) 13 February 1959 (1959-02-13) * the whole document *	1,10	
A	US 3 242 636 A (EVANSON CLIFFORD E ET AL) 29 March 1966 (1966-03-29) * the whole document *	1-12	
A	US 2003/012850 A1 (TURMEL GAETAN) 16 January 2003 (2003-01-16) * the whole document *	1-12	
A	US 3 736 722 A (ROSENBERG H,US) 5 June 1973 (1973-06-05) * the whole document *	1-12	
A	EP 0 943 544 A (DIMA S.R.L) 22 September 1999 (1999-09-22) * the whole document *	1-12	
D,A	EP 0 780 307 A (OPEM S.R.L) 25 June 1997 (1997-06-25) * the whole document *	1-12	TECHNICAL FIELDS SEARCHED (IPC) B65B
The present search report has been drawn up for all claims			
Place of search The Hague		Date of completion of the search 28 April 2006	Examiner Vigilante, M
<p>CATEGORY OF CITED DOCUMENTS</p> <p>X : particularly relevant if taken alone Y : particularly relevant if combined with another document of the same category A : technological background O : non-written disclosure P : intermediate document</p> <p>T : theory or principle underlying the invention E : earlier patent document, but published on, or after the filing date D : document cited in the application L : document cited for other reasons & : member of the same patent family, corresponding document</p>			

2
EPO FORM 1503 03.82 (P04C01)

**ANNEX TO THE EUROPEAN SEARCH REPORT
ON EUROPEAN PATENT APPLICATION NO.**

EP 05 07 6557

This annex lists the patent family members relating to the patent documents cited in the above-mentioned European search report. The members are as contained in the European Patent Office EDP file on
The European Patent Office is in no way liable for these particulars which are merely given for the purpose of information.

28-04-2006

Patent document cited in search report		Publication date	Patent family member(s)	Publication date
US 5074102	A	24-12-1991	NONE	
FR 1172697	A	13-02-1959	NONE	
US 3242636	A	29-03-1966	NONE	
US 2003012850	A1	16-01-2003	CA 2349507 A1	04-12-2002
US 3736722	A	05-06-1973	NONE	
EP 0943544	A	22-09-1999	IT B0980184 A1	20-09-1999
EP 0780307	A	25-06-1997	DE 69612172 D1	26-04-2001
			DE 69612172 T2	27-09-2001
			IT M1952675 A1	19-06-1997
			US 5649412 A	22-07-1997

REFERENCES CITED IN THE DESCRIPTION

This list of references cited by the applicant is for the reader's convenience only. It does not form part of the European patent document. Even though great care has been taken in compiling the references, errors or omissions cannot be excluded and the EPO disclaims all liability in this regard.

Patent documents cited in the description

- EP 0780307 A [0004]