

L. P. LORD.  
 BERRY BOX.  
 APPLICATION FILED APR. 20, 1914.

1,207,421.

Patented Dec. 5, 1916.

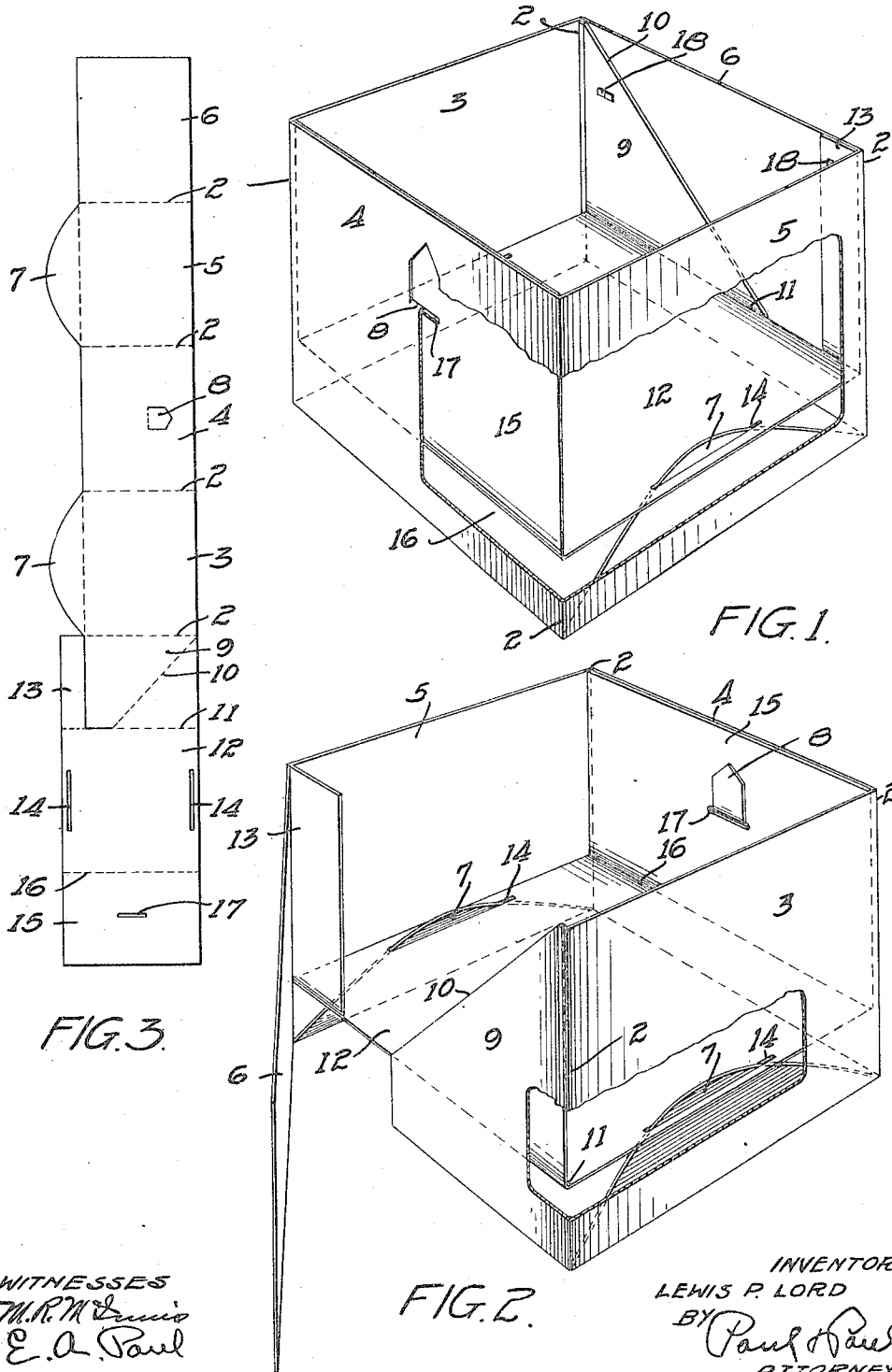

WITNESSES  
 M. R. M. Lewis  
 E. A. Paul

INVENTOR  
 LEWIS P. LORD  
 BY Paul Paul  
 ATTORNEYS

# UNITED STATES PATENT OFFICE.

LEWIS P. LORD, OF MINNEAPOLIS, MINNESOTA, ASSIGNOR OF ONE-THIRD TO F. G. ACOMB, OF MINNEAPOLIS, MINNESOTA, AND ONE-THIRD TO W. H. KILLEN, OF APPLETON, WISCONSIN.

## BERRY-BOX.

1,207,421.

Specification of Letters Patent.

Patented Dec. 5, 1916.

Application filed April 20, 1914. Serial No. 833,060.

*To all whom it may concern:*

Be it known that I, LEWIS P. LORD, citizen of the United States, resident of Minneapolis, county of Hennepin, State of Minnesota, have invented certain new and useful Improvements in Berry-Boxes, of which the following is a specification.

My invention relates to berry boxes of the folding or collapsible type, and the object of the invention is to provide a box of such construction that there will be practically no waste of the stock in cutting out the blank.

A further object is to provide a berry box which can be easily and quickly set up and cannot collapse when in use.

Other objects of the invention will appear from the following detailed description.

The invention consists generally in a berry box constructed as hereinafter described and particularly pointed out in the claims.

In the accompanying drawings forming part of this specification, Figure 1 is a perspective view of a berry box embodying my invention, a portion of the wall being broken away to illustrate the manner of supporting the bottom on the walls of the box, Fig. 2 is a similar view of the opposite side of the box, showing the manner of folding the end of the blank to form a wall panel, Fig. 3 is a plan view of a blank scored and ready for folding.

In the drawing, the blank of flexible material is shown having score lines 2 extending transversely thereof at intervals to form a series of panels 3, 4, 5 and 6. These panels, when the box is set up, form the side walls thereof. The panels 3 and 5 have tongues 7 formed on their lower longitudinal edges and the panel 4 has a tongue 8 pressed or punched therefrom, preferably near the middle portion of the panel. These tongues are for the purpose of supporting the bottom of the box, as will hereinafter appear.

9 is a panel, formed at the end of the panel 3 and separated therefrom by one of the score lines 2 and having a score line 10 extending diagonally thereof from the upper corner adjacent to the panel 3 to and intersecting the score line 11, which separates the panel 9 from the bottom panel 12. This bottom panel is preferably wider than the other panels, and has a tongue 13 formed thereon and extending along the lower edge

of the panel 9, with its end in alinement substantially with the adjacent score line 2. The score line 11 preferably extends across the tongue 13 and on this score line the bottom panel 12 is folded when the box is set up. This bottom panel has longitudinal slots 14 therein and is provided at the end of the blank with a flap 15 that is folded along a score line 16 and is provided with a centrally arranged slot 17.

When the box is set up, the panel 9 is folded along the score line 10, thereby swinging the bottom panel to a position at right angles substantially to the other panels, the object of making the panels in alinement with one another in cutting the blank being for the purpose of economy in the use of stock. The blanks 3, 4, 5 and 6 are then folded along the score lines 2 into a rectangular form, thereby encircling the panel 12 and bringing the tongues 7 into position where they can be thrust through the slots 14 and where the flap 15 can be folded along the score line 16 and the tongue 8 thrust into the slot 17, thereby securely supporting the bottom panel between the walls of the box. The end panel 6 is then folded inwardly, as indicated in Fig. 2, to cover the gap between the panel 9 and the tongue 13 and is secured by suitable means, such as the fastening device or clips 18. The bottom will thus be securely supported and the wall panels will be braced against collapsing, but upon swinging the end panel upwardly to disengage its flap from the tongue 8, the walls may be collapsed to assume a flattened form for storing or shipping purposes. To set up the box, it is only necessary to swing the panels to a rectangular form, and drop down the bottom panel until it is engaged with the tongues 5 and 7.

The box may be made in various sizes, according to the capacity desired, and the weight of the material used may be varied, according to the size and the use to which the article is to be put.

I claim as my invention:

1. A folding box formed of a single sheet of flexible material scored transversely at intervals to form a bottom and a series of wall panels, one of said wall panels being scored diagonally for folding the bottom panel to a position at right angles substantially to the other panels, said bottom panel having a projection thereon and the end

wall panel having means for securing it to said projection and to said diagonally scored panel, the bottom and remaining wall panels having means for interlocking to support said bottom between them.

2. A one piece folding box comprising a blank of flexible material having parallel transverse score lines thereon at intervals to form a series of panels constituting the side walls and bottom of the box, one of said panels being scored diagonally for folding the bottom panel to a position at right angles substantially to the remaining panels, said bottom panel and a portion of said side wall panels having slots and tongues for interlocking to support the bottom panel between the wall panels.

3. A folding box formed of a single sheet of flexible material scored transversely at intervals to form a bottom and a series of wall panels, one of said wall panels being scored diagonally for folding the bottom panel to a position at right angles substantially to the other panels, said bottom panel having a tongue thereon adjacent the lower edge of said diagonally scored panel, the

wall panels being folded on their score lines to encircle the bottom panel and the end wall panel having means for securing it to said tongue and to said diagonally scored panel, said bottom and the remaining wall panels having means for interlocking to support said bottom between them.

4. A one piece berry box comprising a blank scored transversely at intervals to form a bottom and a series of wall panels, said bottom and wall panels being arranged end to end, with the longitudinal edges on one side in alinement with one another, said bottom panel having a projection thereon and an end wall panel having means for securing it to said projection, the bottom and remaining wall panels having means for interlocking to support said bottom between them.

In witness whereof, I have hereunto set my hand this 17th day of April 1914.

LEWIS P. LORD.

Witnesses:

EDWARD A. PAUL,  
C. H. REHFUSS.

Copies of this patent may be obtained for five cents each, by addressing the "Commissioner of Patents, Washington, D. C."