

Oct. 15, 1929.

G. H. STERLING

1,731,508

LOCK

Filed Feb. 15, 1928

2 Sheets-Sheet 1

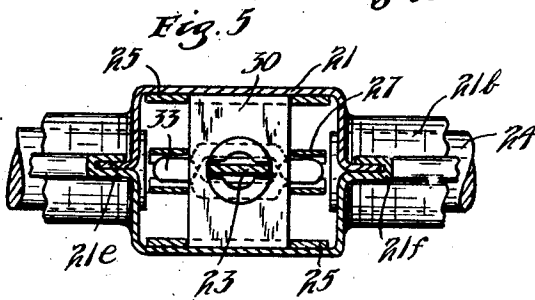
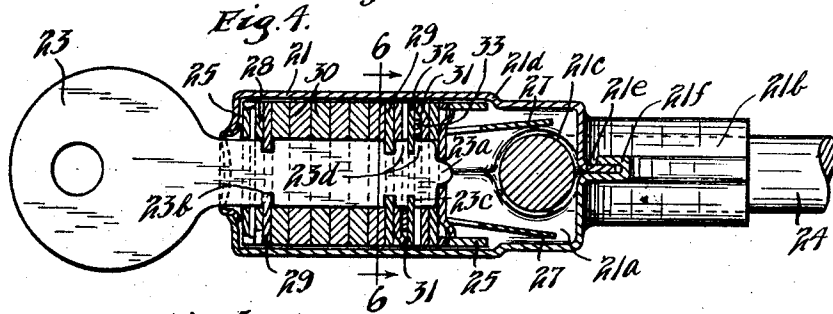
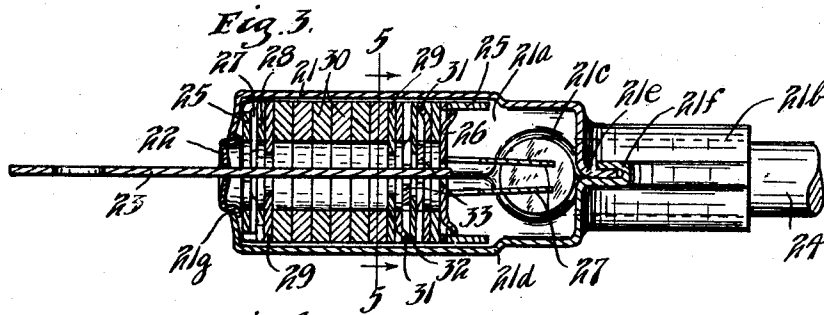
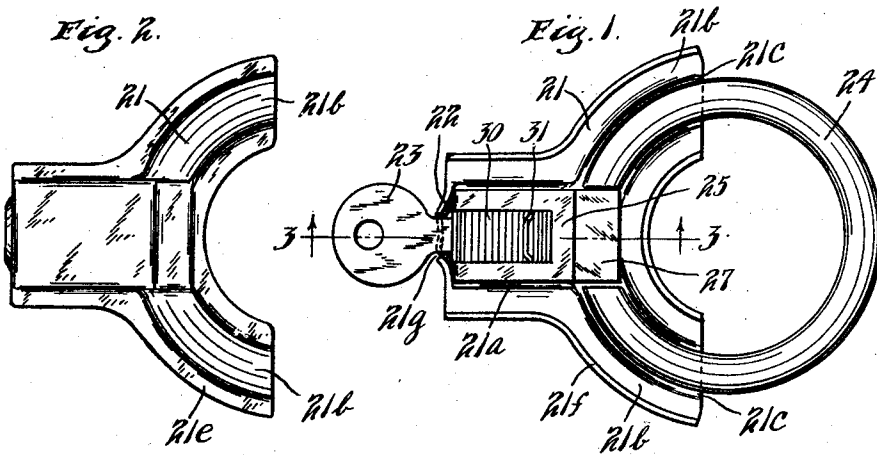

INVENTOR.  
GEORGE H. STERLING.  
BY HIS ATTORNEYS.

*Williamson & Williamson*



# UNITED STATES PATENT OFFICE

GEORGE H. STERLING, OF MINNEAPOLIS, MINNESOTA

## LOCK

Application filed February 15, 1928. Serial No. 254,386.

This invention relates to locks of various types, and particularly to locks of the well known pad lock type.

It further relates to novel improvements on Patent No. 1,520,975 entitled "Padlock" and issued to me on December 30, 1924.

It is the object of this invention to provide a simple and cheaply constructed lock including a novel structure requiring a certain key formation to open the lock, which structure can be simply and easily changed for various locks to require different key formations without necessitating any changes in the construction of the parts making up the lock.

To this end, the invention consists in the novel parts and novel combinations of parts hereinafter defined in the claims, and described in the following specification made in connection with the accompanying drawings, wherein like reference characters refer to the same or similar parts throughout the various views and, in which,

Fig. 1 is a plan view of a lock embodying my invention, the top plate of the casing being removed;

Fig. 2 is a plan view of the top plate for the casing;

Fig. 3 is a vertical section taken on the line 3—3 of Fig. 1, as is indicated by the arrows, and illustrating the parts in locked position;

Fig. 4 is a view similar to Fig. 3, but showing the parts in unlocked position;

Fig. 5 is a vertical section taken on the line 5—5 of Fig. 3, as is indicated by the arrows;

Fig. 6 is a vertical section taken on the line 6—6 of Fig. 4, as is indicated by the arrows;

Fig. 7 is a perspective view illustrating a yoke holding member;

Fig. 8 is a vertical section taken on the line 8—8 of Fig. 7, as is indicated by the arrows;

Fig. 9 is a view in side elevation of a locking member used, with an H-shaped plate applied thereto;

Fig. 10 is a vertical section taken on the line 10—10 of Fig. 9, as is indicated by the arrows;

Figs. 11, 12 and 13 are perspective views

respectively illustrating a spacing plate, a thick ward plate and a thin ward plate;

Fig. 14 is a perspective view illustrating a cam lever;

Fig. 15 is a view in side elevation illustrating a cam lever guide plate;

Fig. 16 is a section taken on the line 16—16 of Fig. 15, as is indicated by the arrows;

Fig. 17 is a view in side elevation of a key abutment plate;

Fig. 18 is a view taken on the line 18—18 of Fig. 17, as is indicated by the arrows;

Fig. 19 is a view in front elevation of a key plate and

Fig. 20 is a section taken on the line 20—20 of Fig. 19, as is indicated by the arrows.

Referring to the drawings, a casing 21 is provided at its rear or lock manipulating end, with a rectangular portion within which a substantially rectangular chamber 21<sup>a</sup> is formed. Projecting forwardly and in opposite directions from the rectangular portion of the casing are two arms 21<sup>b</sup> forming a portion of a circle and having an arcuate shackle passage 21<sup>c</sup> extending therethrough, the bow passage extending through the forward end of the chamber 21<sup>a</sup> but being of considerably less diameter in cross section than the height of the chamber 21<sup>a</sup>. Inwardly projecting shoulders 21<sup>d</sup> are formed adjacent the forward end of the chamber 21<sup>a</sup> for a purpose to be hereinafter described. The casing 21 is formed from two sections, one section being provided with flanges 21<sup>e</sup> at its edges, and the other section being provided with flanges 21<sup>f</sup> at its edges, which are turned over the edges of the flanges 21<sup>e</sup> and pressed downwardly above the flanges 21<sup>e</sup> under great pressure, to form an exceedingly strong casing. At its rear end, the casing is provided with a circular key plate opening 21<sup>g</sup>, and the material forming the casing is slightly rearwardly pressed adjacent the opening for reception of a key plate 22, provided with a flange at its forward side bearing against the walls of the casing adjacent the opening 21<sup>g</sup>, and having a key slot 22<sup>a</sup> formed therein, of any desired shape, for determining the shape of the shank of a key 23 adapted to be used and the shank of which is adapted to be in-

serted through the key way 22<sup>a</sup> into the chamber 21<sup>a</sup>. A ring shaped shackle member 24 is preferably provided which fits within the shackle passage 21<sup>c</sup> for sliding movement therein. The shackle member 24 forms almost a complete ring, but has ends spaced a short distance apart to form shoulders adapted to be placed one at either side of the chamber 21<sup>a</sup> when the parts are in locked position, as is illustrated in Figs. 1, 3 and 5. It will be understood that various types of casings and shackle members may be provided, it being only essential that the casing have a chamber therein, a shackle passage extending through the chamber and a shackle member provided with spaced shoulders adapted to be placed when the shackle member is in one position, so that the shoulders are disposed at the sides of the chamber in the casing.

A right angularly bent U-shaped yoke 25 is fitted within the chamber 21<sup>a</sup> of the casing, so that the base of the U is disposed at the rear end of the chamber to abut the rear wall thereof and the forward end of the key plate 22, while the arms of the U are disposed at the top and bottom of the chamber so that they closely abut the top and bottom walls of the chamber and so that their side edges closely abut the side walls of the chamber and the forward edges of the arm abut the downwardly offset shoulders 21<sup>d</sup>. It will thus be seen that the yoke will be securely held within the chamber 21<sup>a</sup> and will be capable of but slight, if any, movement therein. The rear portion of the yoke, i. e. the base portion of the U forming the yoke, is provided with a keyway 25<sup>a</sup> substantially aligned with the keyway 22<sup>a</sup> in keyplate 22, and of substantially circular shape. In the form illustrated, as shown in Figs. 7 and 8, the keyway 25<sup>a</sup> consists of two slightly offset joining quadrants of a circle cut out from the rear end of the yoke, there being right angle shoulders 25<sup>b</sup> provided which act as stops to limit turning movement of a key inserted through the keyway to movement through a 90° angle. If desired, other types of key openings may be formed in the yoke 25. The arms of the yoke are provided with aligned rectangular apertures 25<sup>c</sup>, and a key abutment plate 26, of a width corresponding to the width of the apertures 25<sup>c</sup>, extends between the arms of the yoke through the apertures 25<sup>c</sup> and has forwardly pressed tabs 26<sup>a</sup> projecting therefrom, which abut the inner sides of the forward ends of the arms of the yoke. The key abutment plate acts to hold the forward ends of the arms of the yoke in braced spaced relationship, and is provided with a central aperture 26<sup>b</sup> within which the forward rounded end 23<sup>a</sup> of key 23 is adapted to fit when the key is fully inserted within the lock. A U-shaped spring plate locking member 27 is provided and rectangular aligned apertures 27<sup>a</sup> are provided in the spring arms of the locking member, which extend from

adjacent the forward ends of the arms rearwardly through the locking member. An H-shaped plate 28 has the inner edges of its projecting arms 28<sup>a</sup> abutting the outer sides of the rear ends of the arms of the locking member, and is provided with projecting central tabs 28<sup>b</sup> which bear against the outer side of the rear end of the locking member, i. e. the base of the U forming the locking member. A central key opening 28<sup>c</sup> is also provided in the H-shaped plate. The locking member 27 and H-shaped plate 28 are disposed in chamber 21<sup>a</sup>, so that the rear side of the H-shaped plate and rear side of the base of the U of the locking member abut the forward side of the rear end of the yoke 25, while the outer side edges of the U plate abut the inner sides of the rear ends of the arms of the yoke 25. Accordingly, when the locking member is in normal position, the arms thereof will extend between the arms of the yoke 25, the arms of the locking member will be spaced from each other and, as the U of the locking member is much narrower than the U of the yoke, the arms of the locking member will extend in spaced substantially parallel relation with the arms of the yoke. The arms of the locking member are considerably greater in length than the arms of the yoke member, so that their forward ends will normally project forwardly beyond the yoke member into the passage 21<sup>c</sup> between the shoulders of the shackle member 24, when the shackle member is disposed as shown in Fig. 1. In this position, the side edges of the forward ends of the arms of the locking member will abut the shoulders of the shackle member to prevent sliding movement thereof through the passage 21, thus locking the shackle member in place. The rectangular apertures 27<sup>a</sup> in the locking member are of such size that they will be aligned with the rectangular apertures 25<sup>c</sup> in the yoke member, so that abutment plate 26 will extend between and through the arms of the locking member without striking the same.

A plurality of rectangular comparatively wide ward plates 29 are provided which are mounted within the apertures 25<sup>c</sup> of the yoke, and extend between the arms of the yoke. The ward plates are provided with ward openings 29<sup>a</sup> for determining the formation of ward notches 23<sup>b</sup> on the sides of the shank of the key 23. A plurality of comparatively wide spacing plates 30 are mounted within the apertures 25<sup>c</sup> and extend between the arms of the yoke and have circular key openings 30<sup>a</sup> therethrough. The relative position of the ward and spacing plates 29 and 30 determine the position that the ward notches 23<sup>b</sup> will take on the shank of the key 23. It will be readily seen that various key formations will be required when the ward and spacing plates are disposed in various arrangements relative to each other. It will also be

clearly seen that the number of ward plates relative to the number of spacing plates may be varied, so as to still further vary the possibilities of the key formation.

5 Disposed between certain of the ward and spacing plates, and mounted in the apertures 25<sup>c</sup> to project between the arms of the yoke, are two cam lever guide plates 31 and a thin ward plate 32. Circular key openings 31<sup>a</sup> are provided through each of the guide plates 10 31, while a ward opening 32<sup>a</sup> is provided within the narrow ward plate 32 and corresponding narrow ward notches 23<sup>c</sup> are provided in the sides of the shank of key 23 to fit the 15 ward opening 32<sup>a</sup>. One of the guide plates 31 abut each side of the thin ward plate 32 and both guide plates are provided with offset portions 31<sup>b</sup> to form channels between the thin ward plate 32 and the guide plates 31, 20 one at one side of the ward plate and below the center thereof, and the other at the other side of the thin ward plate and above the center thereof. A cam lever 33 fits within each of the said channels, is of narrow width 25 and U-shaped and has projecting arms 33<sup>a</sup> which extend outwardly from the sides of the guides 31 and thin ward plate 32, and between the arms of the locking member 27. The cam levers are so disposed that their central 30 portions will project partially into the keyway formed by the substantially alined openings 25<sup>a</sup>, 28<sup>c</sup>, 29<sup>a</sup>, 30<sup>a</sup>, 31<sup>a</sup>, and 32<sup>a</sup>. The shank of the key 23 will be so formed adjacent the narrow ward notches 23<sup>c</sup> that right angle 35 shoulders 23<sup>d</sup> will be provided outwardly from the inner ends of the notches and at either side thereof, which are adapted to engage the cam levers 33. The rear end of the locking member 27, the H-shaped plate 28, 40 the ward plates 29, the spacing plates 30, the guide plates 31, the thin ward plate 32 and the key abutment plate 26 completely fill the apertures 25<sup>c</sup> between the forward ends of the arms of the yoke 25 and the rear of the 45 yoke 25, and the offset portions 31<sup>b</sup> in the guide plates 31 will have some resiliency, so that all of said plates will be held within the yoke in tightly assembled condition under slight spring pressure. In assembling the 50 lock therefor, the whole locking structure may be inserted within the chamber in the casing 21 as a single unit.

When the proper key 23, designed to fit a particular lock, is inserted through the key 55 plate 22 into the key aperture provided through the various ward and spacing plates, the rounded forward end 23<sup>a</sup> of the key will fit within the opening of the abutment plate 26, and the abutment plate will bear against 60 the forward end of the shank of the key to align the various notches on the edges of the shank with the various ward plates 29 and 32. Assuming that the lock is in locked position with the forward ends of the arms of the locking member disposed between the shoulders

on the shackle member, as the key is turned the ward notches 23<sup>b</sup> and 23<sup>c</sup> will permit the key to be moved relative to the ward portions in the ward plates 29 and 32. The shoulders 23<sup>d</sup> on the key will then strike the portions of 70 the cam levers 33 projecting into the keyway, whereupon one of the cam levers 33 will be moved upwardly and the other cam lever will be moved downwardly to spread the arms 33<sup>a</sup> of the cam levers apart. The said arms 33<sup>a</sup> 75 will in turn strike the arms of the locking member 27 and will force the outer ends of the arms of the locking member apart, as the key is turned, until the arms no longer project 80 between the shoulders of the shackle member 24. The shackle member will then be released and may be moved freely through the passage 21<sup>c</sup>. During the spreading movement of the cam levers 33, the spring tension of the arms of the locking member will be opposed to the 85 movement of the arms, and the cam levers 33 cannot turn during the unlocking action, as the arms 33<sup>a</sup> of each cam lever will bear against the two sides of the spring arms of the locking member. After the lock has been 90 unlocked, the key 23 may be turned back to its position of insertion and withdrawn from the lock, whereupon as the shackle member is moved through the passage 21<sup>c</sup> until the 95 shoulders of the shackle member are disposed at either side of the chamber 21<sup>a</sup>, the arms of the locking member 27 will spring downwardly between the shoulders of the shackle member to again lock the same.

It will be seen, during the unlocking action, that the cam levers 33 will be guided by 100 the guide plates 31 and the thin ward plate 32 within the channels between the same, so that the cam levers can only move in a plane at exact right angles to the axis about 105 which the key is turned. Accordingly, the shoulders 23<sup>d</sup> on the shank of the key may be made very narrow in comparison to the ward notches 23<sup>b</sup> in the key. As there will be no 110 movement of the cam levers relative to the length of the key when inserted, as the key is turned, the space taken up on the portion of the key opposing the thin ward plate 32, and the cam levers 33, will be very short relative 115 to the length of the shank of the key. As any master key provided for opening the lock would have to include the narrow notches 25<sup>c</sup>, and the shoulders 23<sup>d</sup>, it can be seen that it would be very difficult to make a master key 120 for the lock, unless the exact position of the thin ward plate 32, relative to the abutment plate 26 were known. In practice, the notches 23<sup>c</sup> are made so narrow that they cannot be made with an ordinary key maker's file. Thus, it becomes almost impossible for un- 125 licensed parties to open the lock. Due to the fact that the position of the thin ward plate 32 and of the cam levers may be varied respective to the abutment plate 26, and also due to the fact that various combinations of 130

spacing plates and wide ward plates may be used, it can be seen that almost innumerable different locks can be made by merely assembling the various plates and cam levers in different relations without varying the construction of the various plates and cam levers in the least. The locks, accordingly, can be put out in a great many different key combinations very cheaply. Due to the fact that the actual locking structure of the device, as distinguished from the casing and the shackle member, is assembled as a separate unit, the same type of locking mechanism may be used for practically every different type of lock, whether padlock, safe lock or door lock, etc.

It will, of course, be understood that various changes may be made in the form, details, arrangement and proportions of the various parts without departing from the scope of the present invention.

What is claimed is:

1. A lock comprising a casing having a chamber therein and a passage extending therethrough and through said chamber, a shackle member mounted within said passage for sliding movement therein and having spaced shoulders adapted to extend adjacent said chamber, a locking member mounted in said chamber and having a spring arm adapted to normally extend under resilient tension with the sides of the arm between the shoulders of said shackle member to lock the same from movement, a cam lever mounted in said casing and bearing against said spring arm, said cam lever being adapted to be actuated by a key to cause the cam lever to move the arm of the said locking member against the spring tension thereof from between the shoulders of said shackle member, said cam lever being adapted to be mounted in various positions in said casing to vary the key formation without varying the formation of said locking member.

2. The structure defined in claim 1, and a plurality of plates mounted in said chamber and having substantially alined ward openings for determining the form of key.

3. The structure defined in claim 1, and a plurality of ward and spacing plates mounted in said chamber and having substantially alined openings therein for determining the formation of ward portions on a key capable of being used in actuating said cam lever, and said spacing plates determining the spacing of the ward portions on the key.

4. The structure defined in claim 1, said cam lever being mounted in said casing for only straight movement in a single plane, whereby a key can be used having narrow cam lever actuating portions.

5. A lock comprising a casing having a chamber therein and a passage extending therethrough and through said chamber, a

shackle disposed in said passage for sliding movement and having shoulders adapted to be placed at the sides of said chamber, a locking member disposed in said chamber and having a spring arm, the sides of the outer end of which are adapted normally to be held between the shoulders of said shackle by spring tension exerted in a direction substantially normal to the general direction of movement of said shackle through said passage, and a member in said chamber and bearing against said spring arm, said last mentioned member being mounted for only straight movement in a single plane, said chamber having a key opening therein extending at right angles to the plane of movement of said last mentioned member and into which said last mentioned member normally extends, whereby a key may be inserted within said key opening and may be turned to bear against said last mentioned member and cause the same to act against the spring arm of said locking member, to move the spring arm against the tension thereof from between the shoulders of said shackle, said last mentioned member being incapable of longitudinal movement in said key opening as the key is turned.

6. A lock comprising a casing having a chamber therein and a passage extending therethrough and through said chamber, a shackle member mounted within said passage for sliding movement therein and having spaced shoulders adapted to be placed so that one shoulder extends adjacent each side of said chamber, a U-shaped locking member mounted in said chamber, and having a pair of spring arms adapted to normally extend under resilient tension with the sides thereof between the shoulders of said shackle member to lock the same from movement, a pair of cam levers mounted in said chamber between the arms of said locking member for spreading movement in opposite directions, said casing having a key opening therein into which said cam levers project, whereby a key may be inserted within said key opening and may be turned to spread said cam levers apart to move the arms of said locking member from between the shoulders of said shackle member.

7. A lock comprising a casing having a chamber therein and a passage extending therethrough and through said chamber, a shackle member mounted within said passage for sliding movement therein and having spaced shoulders adapted to be placed adjacent the sides of said chamber, a U-shaped locking member mounted in said chamber and having a pair of spring arms adapted to normally extend under resilient tension with the sides thereof between the shoulders of said shackle member to lock the same from movement, a thin ward plate disposed in said chamber, a pair of cam levers mounted in

said chamber between the arms of said locking member for spreading movement in opposite directions, one of said cam levers abutting one side of said thin ward plate and the other of said cam levers abutting the other side of said thin ward plate, there being a key opening projecting through said casing and said thin ward plate, said cam levers normally projecting into said key opening whereby a key may be inserted within said key opening and may be turned to spread said cam levers to cause the arms of said locking member to move from between the shoulders of said shackle member.

8. The structure defined in claim 7, and a plurality of thick ward and spacing plates disposed in said chamber and having openings therethrough substantially alined with said key opening, for determining the formation of key that may be used.

9. The structure defined in claim 7, and a pair of guide plates disposed in said chamber, one of which has portions abutting one side of said thin ward plate and the other of which has portions abutting the other side of said thin ward plate, said guide plates having grooves therein within which said cam levers are mounted for movement, said guide plates and said thin ward plate limiting the movement of said cam levers in all directions except in a plane normal to the axis about which the key may be turned when inserted within said key opening.

10. In a lock assembly, the combination of a U-shaped yoke, the two arms thereof having alined rectangular apertures therethrough, a U-shaped spring locking member mounted within said yoke and also having rectangular apertures through its arms in alinement with the rectangular apertures through the arms of said yoke, a plurality of spacing and ward plates extending through said alined apertures and between the arms of said yoke, said ward and spacing plates having substantially alined key openings therein for determining the shape of a key to be used, a pair of cam levers mounted between certain of said ward and spacing plates and having their outer ends extending between the arms of said locking member, said cam levers having portions partially projecting into the keyway formed between the said plates and through the key openings therein, whereby a key formed to fit said key openings may be inserted within said keyway and turned to strike said cam levers and spread the same apart, thereby spreading the outer ends of the arms of said locking member.

11. In a lock construction, a U-shaped yoke, said yoke having rectangular apertures extending through the sides thereof, a U-shaped spring locking member extending between the arms of said yoke and having rectangular apertures through its arms extending from adjacent the forward ends of the

arms and centrally and rearwardly through the arms, an H-shaped plate, the inner sides of the projecting arms of which abut the outer sides of each of the rear ends of the arms of said spring locking member to strengthen the same and prevent distortion thereof, said H-shaped plate having tabs projecting outwardly from its central portion and adapted to strike the forward sides of the rear end of said spring locking member to retain the H-shaped plate in position, said H-shaped plate abutting the central portion of said U-shaped yoke, so that the apertures through the arms of said spring locking member are alined with the apertures through said yoke, and members adapted to be acted on by a key to spread the free ends of the arms of said spring locking member.

12. In a lock structure, a U-shaped yoke having rectangular alined apertures in the arms thereof, a U-shaped spring locking member disposed centrally between the arms of said U-shaped yoke and having rectangular apertures therein alined with the rectangular apertures in said yoke, a plurality of ward and spacing plates having substantially alined key openings therethrough, said ward and spacing plates being mounted in the rectangular apertures through the arms of said yoke and locking member and extending between the arms of said yoke, said ward and spacing plates largely determining the shape of a key to be used, means with which a key insertible through said key opening is adapted to engage as it is turned to spread the outer ends of the arms of said locking member, and a key abutment plate fitting within the alined apertures through said yoke and locking member adjacent the outer end thereof, extending between the arms of said yoke and having small projections on its outer side abutting the central sides of the outer ends of the arms of said yoke, to hold the same in braced spaced relation.

13. A lock comprising, a casing, having a chamber therein and a passage extending therethrough and through said chamber, a shackle slidably mounted within said passage and having spaced shoulders adapted to extend adjacent said chamber, a U-shaped resilient locking member mounted within said chamber and having arms adapted to normally extend under resilient tension with the sides thereof between the shoulders of said shackle to lock the same from movement, a plurality of thick plates disposed within said chamber and having ward openings for determining the form of key to be used, a narrow ward plate having a ward opening therein through which the key must fit, a pair of thin cam levers having arms disposed between the arms of said locking member and disposed in said chamber so that one cam lever abuts each side of said thin ward plate, said levers being so mounted for move-

ment that they will be spread apart by a key  
of such form that it will fit within the ward  
openings of said thick plates and said nar-  
row plate for turning movement in respect  
5 thereto to move the arms of said locking  
member from between the shoulders of said  
shackle member.

In testimony whereof I affix my signature.  
GEORGE H. STERLING.

10

15

20

25

30

35

40

45

50

55

60

65