

W. SPARKS.  
 METHOD AND MACHINE FOR CREASING BOOK LEAVES.  
 APPLICATION FILED FEB. 11, 1910.

996,808.

Patented July 4, 1911.

2 SHEETS—SHEET 1.

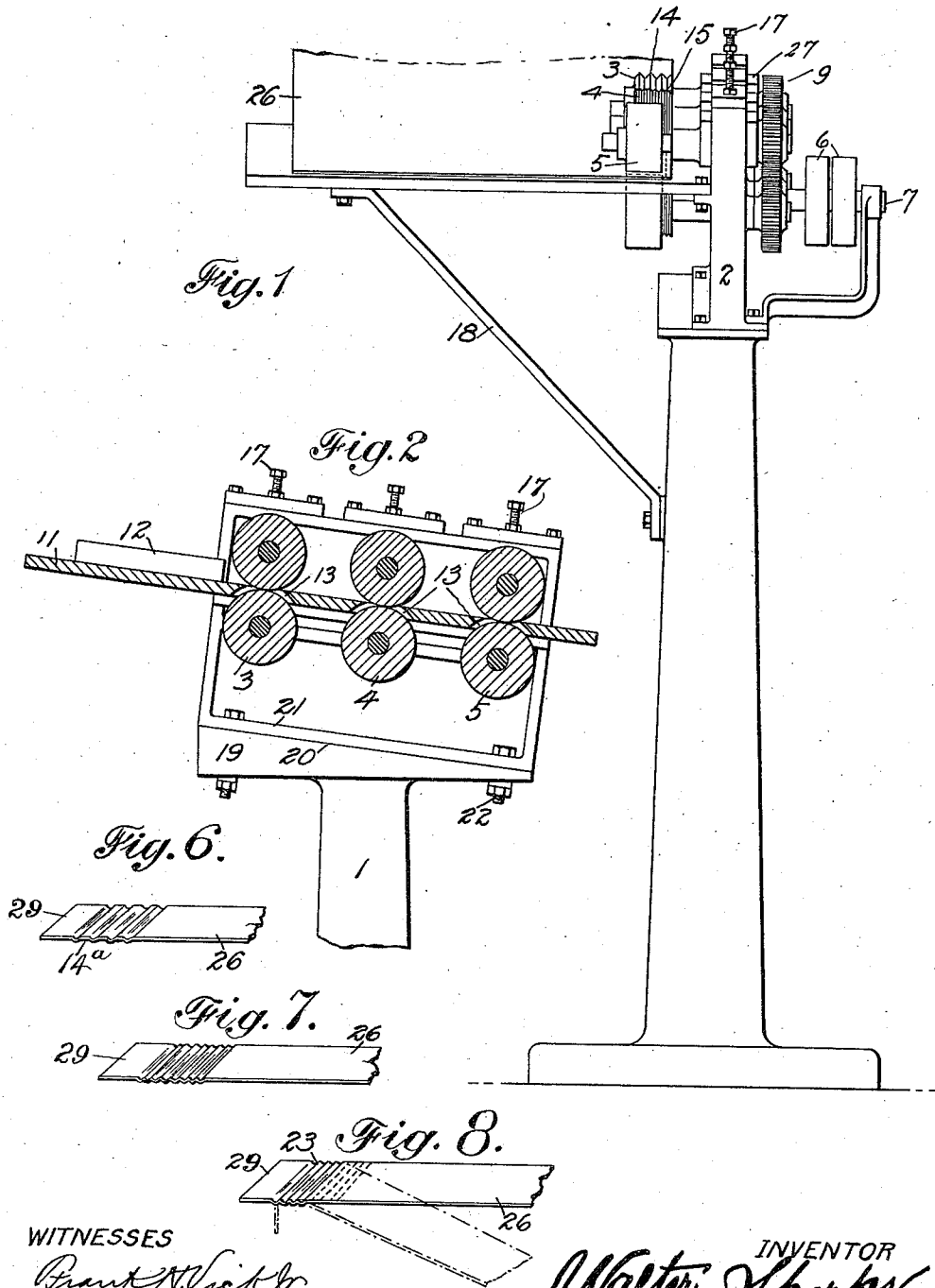

WITNESSES

*Brant N. Vick Jr.*  
*Raymond Boig*

INVENTOR

*Walter Sparks,*  
*per Charles A. Sparks,*  
*Atty.*

W. SPARKS.  
 METHOD AND MACHINE FOR CREASING BOOK LEAVES.  
 APPLICATION FILED FEB. 11, 1910.

996,808.

Patented July 4, 1911.

2 SHEETS—SHEET 2.

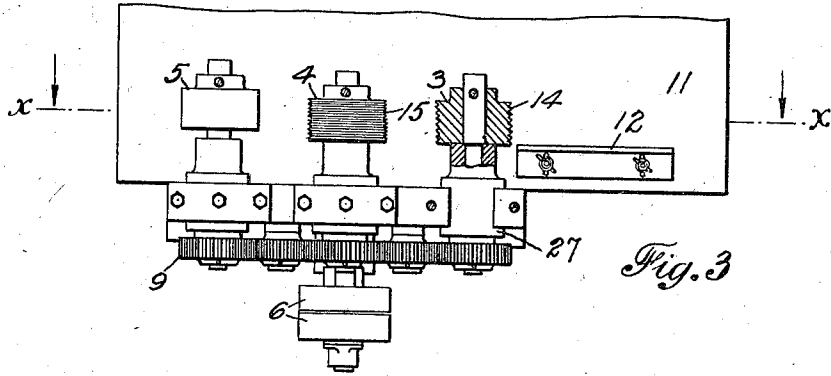

Fig. 3

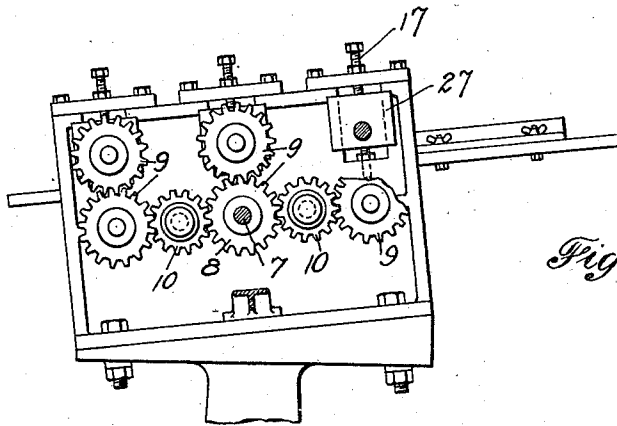

Fig. 4

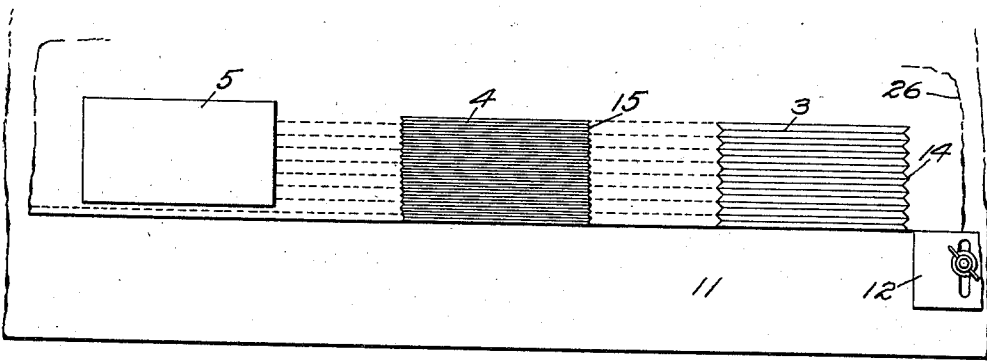

Fig. 5

WITNESSES

*Frank N. Vick Jr.*  
*Robert Boiz*

INVENTOR

*Walter Sparks,*  
*per Charles W. Baker,*  
*Att'y.*

# UNITED STATES PATENT OFFICE.

WALTER SPARKS, OF NEW YORK, N. Y.

METHOD OF AND MACHINE FOR CREASING BOOK-LEAVES.

996,808.

Specification of Letters Patent.

Patented July 4, 1911.

Application filed February 11, 1910. Serial No. 543,337.

To all whom it may concern:

Be it known that I, WALTER SPARKS, a citizen of the United States of America, residing at New York city, in the county of New York and State of New York, have invented certain new and useful Improvements in Methods of and Machines for Creasing Book-Leaves, of which the following is a specification, reference being had therein to the accompanying drawing.

This invention relates to a method of and apparatus for creasing book leaves for the purpose of producing a hinged joint so that they will lie flat when opened.

The object of my invention is not only to produce a superior article, but to provide an apparatus and method by which the manufacture of them can be accomplished with greater rapidity, ease and economy.

To these ends my invention consists in the peculiar features, means and apparatus more fully described hereinafter and pointed out in the claims.

In the accompanying drawings, Figure 1 is an end elevation of my complete invention. Fig. 2, a longitudinal section through the line *x x* of Fig. 3. Fig. 3, a top view of the machine in which some of the parts are shown in section. Fig. 4, a side elevation showing the driving gears. Fig. 5, a plan view of the rolls. Figs. 6, 7 and 8, views of the product of the machine in successive stages of the process.

My mechanism is mounted upon pedestal 1 which carries a housing 2 in which is journaled a series of rolls 3, 4 and 5 arranged in inclined alinement. These rolls are driven by fast and loose pulleys 6 on shaft 7 through the medium of a train of gears actuated by a master gear 8 fixed to the shaft 7. This master gear actuates the three pairs of gears 9 through the medium of intermediate idle gears 10, whereby all the rolls are driven simultaneously in one direction.

The paper leaves 26 to be creased are fed to the rolls upon a table 11 provided with a guide 12. This table slopes downward slightly from left to right, extending under all the upper rolls and out beyond them on the right hand side from the operator. Recesses 13 are cut through the table to receive the peripheries of the rolls where they come together. The first pair of rolls 3 is provided with meshing corrugations or teeth 14 adapted to form in the paper leaf a series

of corresponding parallel creases or corrugations 14<sup>a</sup>. The second pair of rolls 4 is provided with narrower corrugations or teeth 15 meshing with one another and having a width exactly one-half that of the preceding rolls. These narrower corrugations form double the number of lines in the paper. The last pair of rolls 5 are for flattening the paper after it has passed through the first two pair of rolls. It is therefore provided with a smooth periphery. The left hand ends of these flattening rolls are positioned slightly out of alinement with the preceding rolls, in order to leave an unflattened portion 23 in the stub 29 of the leaf 26. Each pair of rolls is mounted in vertically movable bearings 27 having adjusting screws 17, whereby the rolls may be held apart just far enough to break the sizing or crust of the paper without severing or injuring its fiber, but destroying its resiliency at the broken line. The table is strongly sustained by a brace 18. The housing 2 is secured to the pedestal 1 through the medium of an integral cap 19 having an inclined surface 20 to which flanges 21 are secured by the bolts 22.

Thus constructed the operation of the machine may be described as follows: The sized or calendered book leaf to be creased is first placed upon the table 11 against the guide 12, and fed into the upper side of the machine where it is first gripped by the rolls 3 which carry it forward, and at the same time create the larger creases 14<sup>a</sup> in the paper as seen more clearly in Fig. 6. Continuing, the paper is next carried forward between the second pair of rolls 4 which have the smaller corrugations, whereby the first set of creases are reduced in depth and intervening lines are broken in the paper between them as shown in Fig. 7. The continued forward movement of the paper takes it between the smooth flattening rolls 5, which flatten down the major portion 24 of all the creases, leaving the minor portion 23 of the creased strip provided with small corrugations as seen in Fig. 8. The point where the flattened portion 24 leaves off and the unflattened portion 23 commences constitutes the hinge 25 of the leaf 26. Dotted lines in Fig. 8 show the completed leaf bent in a different position.

It is apparent that my invention could be varied in many ways, that might naturally suggest themselves to those skilled in the

art, without departing from the range of its essential characteristics; therefore, I do not limit myself to the exact means shown and described, but consider myself entitled to all those variations which come within the scope and spirit of my device.

Having thus described my invention, what I claim as new and desire to secure by Letters Patent, is:

10 1. The method of producing integral hinges in paper book leaves for flat-leaf books or the like, which method consists in first forming in and across the leaf a strip composed of a series of creases; second, forming additional lines between the first formed lines thereby doubling the number of lines, and thirdly, flattening a longitudinal portion of the creased or lined strip throughout its length, leaving the remaining portion unflattened, whereby an integral hinge is formed between the two portions.

20 2. The method of creasing paper book leaves for flat leaf books and the like, which consists in first forming in the leaf a series

of creases, secondly forming additional creases between the first series, and thirdly flattening a portion of the creased strip, leaving the remaining portion unflattened, to produce an integral hinge.

30 3. In a machine for treating paper leaves for flat leaf books and the like, the combination with a suitable table over which the leaves pass under treatment, of corrugated rolls which form corrugations in the paper, a second pair of corrugated rolls whose teeth are of finer gage, and which form additional corrugated lines in the paper between the first series of lines; and flattening rolls which press down a portion of the creased strip leaving the remaining portion unflattened whereby an integral hinge is formed between the two portions.

In testimony whereof I affix my signature in presence of two witnesses.

WALTER SPARKS.

Witnesses:

R. G. DuBois,  
JEANNETTE STORK.

Copies of this patent may be obtained for five cents each, by addressing the "Commissioner of Patents, Washington, D. C."