



(86) Date de dépôt PCT/PCT Filing Date: 2001/09/27
 (87) Date publication PCT/PCT Publication Date: 2002/04/04
 (85) Entrée phase nationale/National Entry: 2003/03/27
 (86) N° demande PCT/PCT Application No.: CA 2001/001368
 (87) N° publication PCT/PCT Publication No.: 2002/027136
 (30) Priorité/Priority: 2000/09/28 (60/235,911) US

(51) Cl.Int.⁷/Int.Cl.⁷ E06B 9/18, E06B 9/02
 (71) Demandeur/Applicant:
RAVCO INNOVATIONS INC., CA
 (72) Inventeurs/Inventors:
LANE, JOHN ALEXANDER, CA;
COHEN-RAVID, MOSHE, CA
 (74) Agent: FETHERSTONHAUGH & CO.

(54) Titre : SYSTEME DE VERROUILLAGE D'UNE BOUCLE SANS FIL CONCUE POUR ENTRAINER UNE BARRIERE DE SECURITE

(54) Title: SECURITY BARRIER ENDLESS DRIVE LOOP LOCK

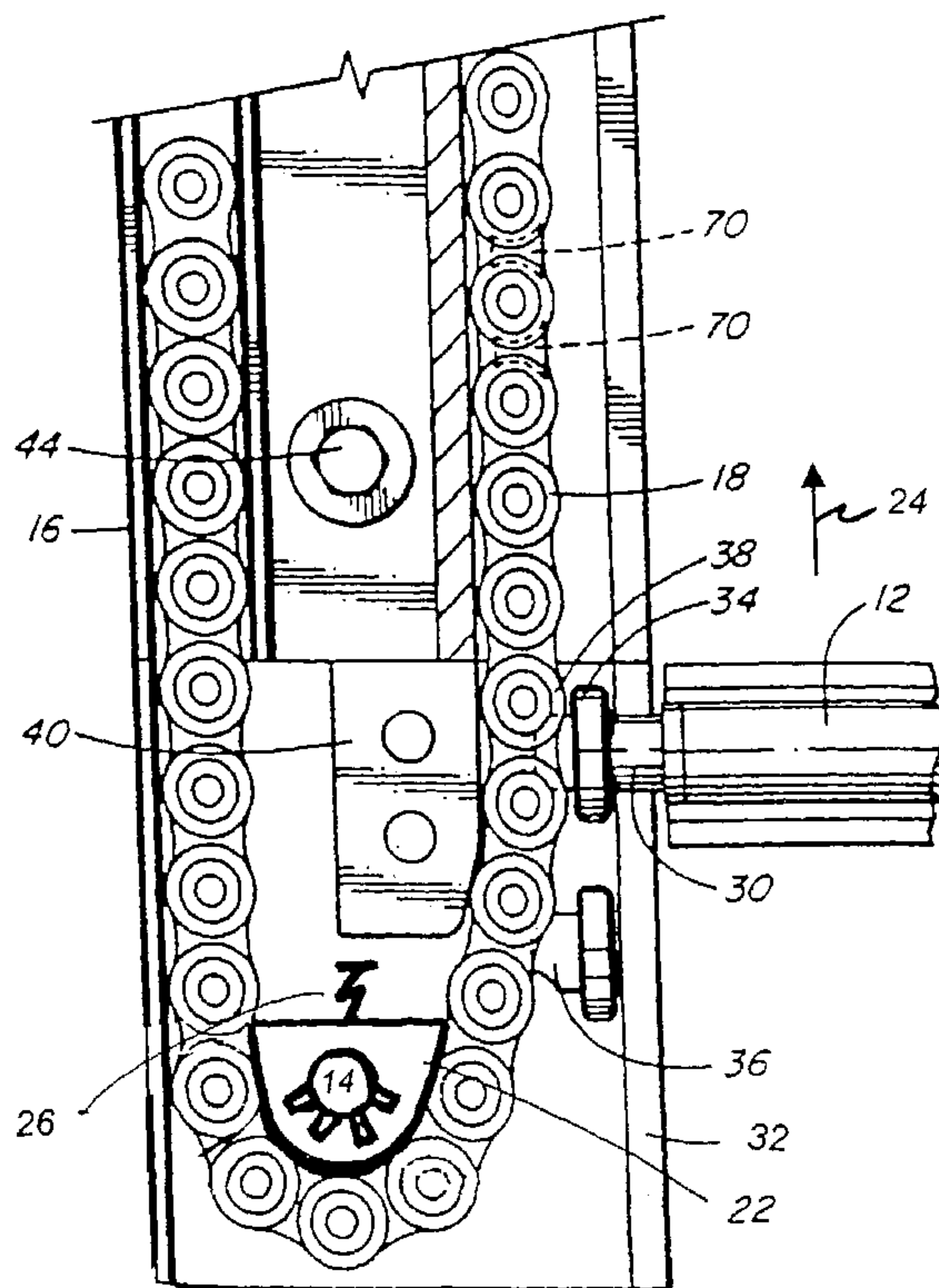

(57) Abrégé/Abstract:

In one aspect, the invention provides an endless loop lock including a drive wheel adapted to be driven or not driven. An endless loop may be provided, engaging the drive wheel and adapted to be driven by the drive wheel to move a device, such as a security bar, connected to the endless loop. A guide may be provided, biased against the endless loop at a position spaced apart from the drive wheel. A lock may be provided, for engaging the endless loop to inhibit movement of the endless loop, the guide being positioned to bias the endless loop out of engagement with the lock when the endless loop is driven by the drive wheel. The lock may be actuated by a force applied to the device connected to the endless loop when the drive wheel is not driven.

(12) INTERNATIONAL APPLICATION PUBLISHED UNDER THE PATENT COOPERATION TREATY (PCT)

(19) World Intellectual Property Organization
International Bureau(43) International Publication Date
4 April 2002 (04.04.2002)

PCT

(10) International Publication Number
WO 02/27136 A1

- (51) International Patent Classification⁷: E06B 9/18, 9/02
- (21) International Application Number: PCT/CA01/01368
- (22) International Filing Date:
27 September 2001 (27.09.2001)
- (25) Filing Language: English
- (26) Publication Language: English
- (30) Priority Data:
60/235,911 28 September 2000 (28.09.2000) US
- (71) Applicant (for all designated States except US): RAVCO INNOVATIONS INC. [CA/CA]; C/O New Age Properties, 409 Granville Street, Suite 200, Vancouver, British Columbia V6C 1T2 (CA).
- (72) Inventors; and
- (75) Inventors/Applicants (for US only): COHEN-RAVID, Moshe [IL/CA]; C/O New Age Properties, 409 Granville Street, Suite 200, Vancouver, British Columbia V6C 1T2 (CA). LANE, John, Alexander [CA/CA]; C/O New Age Properties, 409 Granville Street, Suite 200, Vancouver, British Columbia V6C 1T2 (CA).
- (74) Agents: FETHERSTONHAUGH & CO. et al.; 650 West Georgia Street, Box 11560, Vancouver Centre, Vancouver, British Columbia V6B 4N8 (CA).
- (81) Designated States (national): AE, AG, AL, AM, AT, AU, AZ, BA, BB, BG, BR, BY, BZ, CA, CH, CN, CO, CR, CU, CZ, DE, DK, DM, DZ, EC, EE, ES, FI, GB, GD, GE, GH, GM, HR, HU, ID, IL, IN, IS, JP, KE, KG, KP, KR, KZ, LC, LK, LR, LS, LT, LU, LV, MA, MD, MG, MK, MN, MW, MX, MZ, NO, NZ, PH, PL, PT, RO, RU, SD, SE, SG, SI,

[Continued on next page]

(54) Title: SECURITY BARRIER ENDLESS DRIVE LOOP LOCK

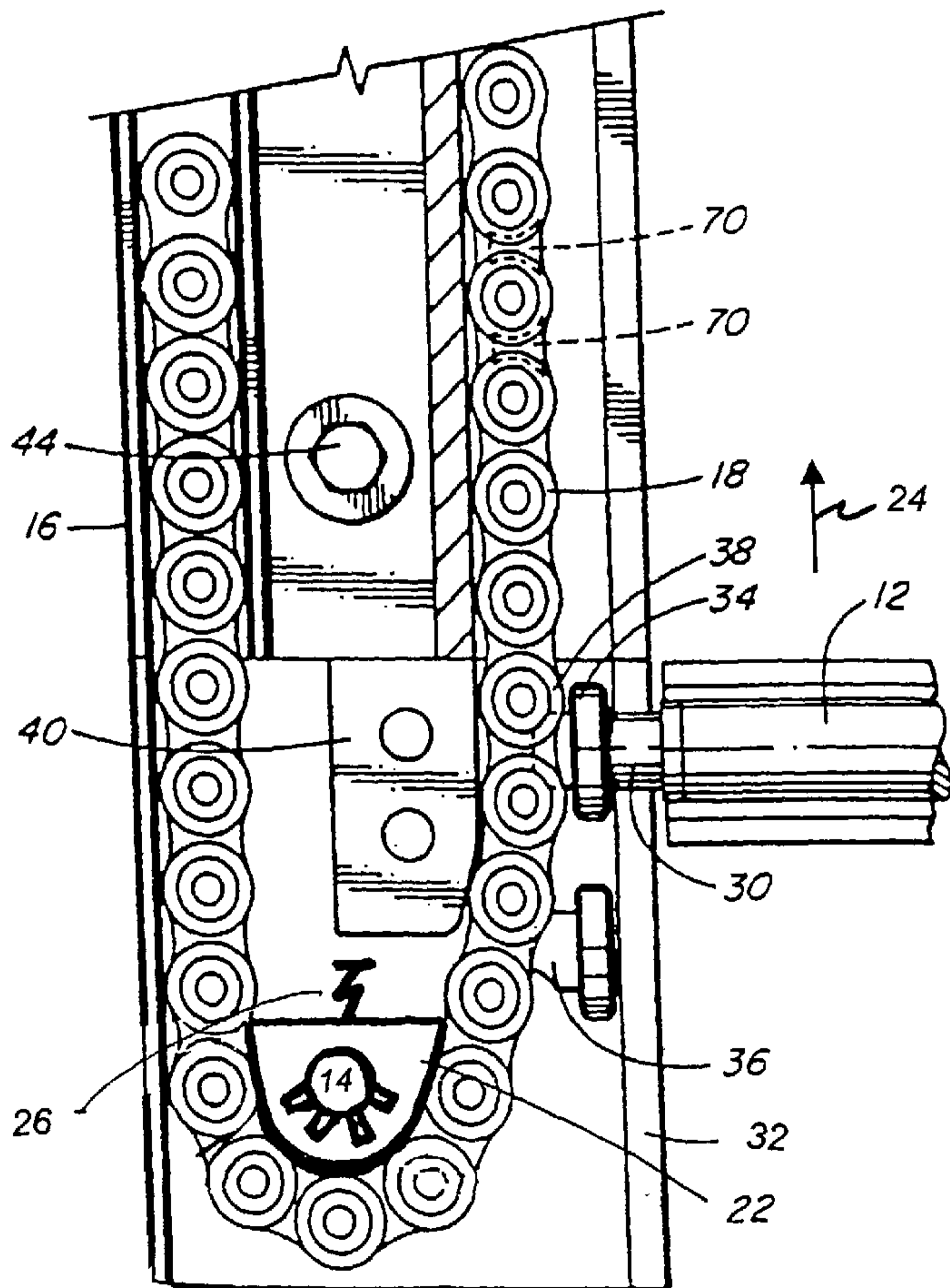

(57) Abstract: In one aspect, the invention provides an endless loop lock including a drive wheel adapted to be driven or not driven. An endless loop may be provided, engaging the drive wheel and adapted to be driven by the drive wheel to move a device, such as a security bar, connected to the endless loop. A guide may be provided, biased against the endless loop at a position spaced apart from the drive wheel. A lock may be provided, for engaging the endless loop to inhibit movement of the endless loop, the guide being positioned to bias the endless loop out of engagement with the lock when the endless loop is driven by the drive wheel. The lock may be actuated by a force applied to the device connected to the endless loop when the drive wheel is not driven.

WO 02/27136 A1



SK, SL, TJ, TM, TR, TT, TZ, UA, UG, US, UZ, VN, YU, ZA, ZW.

(84) Designated States (regional): ARIPO patent (GH, GM, KE, LS, MW, MZ, SD, SL, SZ, TZ, UG, ZW), Eurasian patent (AM, AZ, BY, KG, KZ, MD, RU, TJ, TM), European patent (AT, BE, CH, CY, DE, DK, ES, FI, FR, GB, GR, IE, IT, LU, MC, NL, PT, SE, TR), OAPI patent (BF, BJ, CF, CG, CI, CM, GA, GN, GQ, GW, ML, MR, NE, SN, TD, TG).

Published:

- *with international search report*
- *before the expiration of the time limit for amending the claims and to be republished in the event of receipt of amendments*

For two-letter codes and other abbreviations, refer to the "Guidance Notes on Codes and Abbreviations" appearing at the beginning of each regular issue of the PCT Gazette.

SECURITY BARRIER ENDLESS DRIVE LOOP LOCK

FIELD OF THE INVENTION

5 The invention is in the field of mechanical devices for locking and guiding endless loops, such as an endless loop adapted for driving a security barrier.

BACKGROUND OF THE INVENTION

10 Security bars may be used to cover windows and doors to secure a building. For example, U.S. Patent No. 5,957,181 (Cohen-Ravid) discloses a security bar assembly that has a plurality of bars extending across an opening. The bars have ends that join to drive chains with bar ends that cooperate with chain links to drive the bars. A drive mechanism is disclosed that moves the drive chain such that the bars slide, and therefore cover, the opening. A variety of alternative security bar installations may be used, in which an endless loop drives the security bars. In such installations, it is desirable to provide a lock that secures the security bars in place once they have
15 been lowered.

SUMMARY OF THE INVENTION

20 The invention provides a locking device adaptable for use with security bar systems. The locking device may be adapted to inhibit the movement of a drive loop which is operably connected to a security bar drive mechanism. The locking device may be adapted to engage the drive loop chain in such a way that when the security bars are closed, an attempt to open the security barrier will cause the braking device to engage the chain, locking the drive chain to prevent movement of the security bars.
25 The lock of the invention may also be adapted for a wide variety of alternative locking or braking functions, in some embodiments serving both to lock closed security bars against an opening movement while also providing a safety mechanism that locks the bars against a closing movement when an object, such as a person's arm, interferes with the closing movement of the bars (to help prevent injuries caused by
30 movement of the bars).

In one aspect, the invention provides an endless loop lock including a drive wheel adapted to be driven or not driven. The drive wheel may have a resistance to rotation when an external force attempts to move the drive wheel at a speed that is different from the drive speed. For example, such resistance may be provided by a drive wheel that is driven by an electric motor, wherein the motor may offer a resistance to any rotational movement when it is not energized, or a resistance to rotation at any speed other than the speed at which the motor is being electrically driven. The drive wheel accordingly acts as a tensioning mechanism, and provides a means for exerting tension on the endless loop, by providing a mechanism that engages the endless loop in a manner capable of resisting movement of the endless loop. In alternative embodiments, other mechanisms may be provided as means for exerting tension on the endless loop, such as a sprocket or guide that does not serve as a drive wheel because it is not driven.

An endless loop, such as a chain, may be provided, engaging the drive wheel or alternative means for exerting tension on the endless loop. In some embodiments, the endless loop may be adapted to be driven by the drive wheel to move a device, such as a security bar, connected to the endless loop. A guide may be provided, biased against the endless loop at a position spaced apart from the drive wheel.

A lock may be provided, for engaging the endless loop to inhibit movement of the endless loop, the guide being positioned to bias the endless loop out of engagement with the lock when the endless loop is not under a locking tension, such as when the endless loop is driven by the drive wheel. The lock may for example be actuated by a force applied to a device connected to the endless loop when the drive wheel is not driven, or when the device is urged to move more quickly or more slowly than the speed conferred by the drive wheel, so that a locking tension is applied to the endless loop. The lock may accordingly be actuated when the force applied to the device urges the device connected to the endless loop to move against the resistance to rotation afforded by the drive wheel. In alternative embodiments, the resistance to movement may be provided by a clamp that engages the endless loop, a sprocket

engaging the endless loop or alternative means for exerting tension on the endless loop. The force applied to the device exerts a locking tension on the endless loop, the locking tension being between the device and the drive wheel (or clamp or alternative means for exerting tension on the endless loop), so that the locking tension is exerted
5 across the guide member. The endless loop thereby engages the lock when the locking tension on the endless loop is sufficient to displace the guide (which may be detected by a detector to provide an indication that the lock has been actuated). The engagement of the endless loop by the lock may prevent movement of the endless loop, as in the case of splines on a fixed gear that engage a chain. Alternatively, the
10 engagement of the endless loop by the lock may serve merely to inhibit the movement of the endless loop, providing a braking effect.

In some embodiments, the lock includes four elements: an endless loop, a mechanism for tensioning the loop, a device attached to the loop which may be used
15 to exert force on the loop against the tension provided by the tensioning mechanism and a lock or locking member which is engaged when sufficient tension is applied to the loop. The loop engages the tensioning mechanism, such as a drive wheel, at a first portion of the loop, and engages the lock at a second portion of the loop. The lock is engaged when force is exerted on the loop by the device towards the tensioning
20 mechanism, so that the second portion of the loop is subject to sufficient tension.

BRIEF DESCRIPTION OF THE DRAWINGS

Figure 1 is a front perspective view of a security bar installation over a window, showing the ends of the security bars running in side channels provided on
25 the sides of the window.

Figure 2 is a partially broken away plan view of a top portion of a security bar side channel, showing the interior of a channel in which the ends of security bars are retained, the security bars are shown in partial cross-section, with some of the ends of
30 the security bars connected to an endless loop chain which is driven by a drive wheel.

Figure 3 is a partially broken away plan view of a bottom portion of a security bar side channel, showing the interior of the channel in which the ends of security bars are retained, with the chain that connects to the security bars shown engaging a lock wheel when a guide has been displaced by a force exerted on a security bar.

5

Figure 4 is a top sectional view of a security bar side channel, showing the endless loop chain connected to a security bar, with the channel fastened to a window frame.

10

Figure 5 is a partially broken away plan view of a bottom portion of a security bar side channel from Figure 3, showing the guide member displaced so that the endless loop engages the braking wheel.

15

Figure 6 is a schematic plan view of an alternative endless loop locking arrangement of the invention, showing the guide biased against the inside of the endless loop to hold the endless loop out of engagement with the lock.

20

Figure 7 is a schematic plan view of an alternative endless loop locking arrangement of the invention, showing the guide biased against the outside of the endless loop to hold the endless loop out of engagement with the lock.

DETAILED DESCRIPTION

An endless loop lock of the invention may be used with a security barrier placed over an opening, as shown in Figure 1, where the security barrier comprises a plurality of security bars 12 retained in channels 16 on either side of the opening. A drive mechanism for security bars 12 may be provided in one or both of channels 16, as shown in Figures 2, 3 and 4.

As shown in Figure 2, a drive wheel 20 may be mounted for driven rotation in a top portion of channel 16. Drive wheel 20 may be adapted to be driven or not driven, so that it has two states that effect movement of endless loop 18. Drive wheel

30

20 may have a resistance to rotation when not driven, as for example may be the case with a drive wheel driven by an electric motor, wherein the motor may offer a resistance to movement when it is not energized or when an attempt is made to rotate the motor at a speed other than the speed at which it is driven.

5

Endless loop **18** may be a chain, as illustrated, engaging drive wheel **20** at a first portion of loop **18**, wherein loop **18** is adapted to be driven by drive wheel **20** to move a device, such as security bar **12**. In the illustrated embodiments, security bars **12** are shown connected to endless loop **18** by bar ends **36** that engage the chain links, while enlarged bar end pieces **34** interact with channel lip **32** to help to retain bars **12** in channels **16**. Alternatively, the device may for example be any component driven by the endless loop, such as shutters or conveyor belt attachments such as buckets (where the endless loop is a conveyor belt).

10

15

As shown in Figure 3, guide **22** may be provided, biased against a second portion of endless loop **18** at a position spaced apart from drive wheel **20**. As illustrated, guide **22** may be mounted to channel **16** for slidable up and down movement. Lock **14** may be provided in Figure 3, for engaging endless loop **18**, to inhibit movement of endless loop **18**. Guide **22** being positioned to bias endless loop **18** out of engagement with lock **14** when endless loop **18** is driven by drive wheel **20**.

20

25

Lock **14** may be actuated by a force applied to security bar **12** connected to endless loop **18** when drive wheel **20** is not driven. For example, lock **14** may be actuated when the force applied to security bar **12** urges security bar **12** upwardly, as shown in Figure 3 by arrow **24**, against the resistance to rotation afforded by drive wheel **20**. In some embodiments, lock **14** will not be actuated when security bar **12** is urged downwardly, since such movement will not exert a tension on the second portion of endless loop **18** across guide **22**.

30

As illustrated, the upward force **24** applied to security bar **12** would exert a tension on endless loop **18**, the tension being between security bar **12** and drive wheel

20, and across guide 22. Endless loop 18 engages lock 14 when the tension on endless loop 18 is sufficient to displace guide 22, which may slide upwardly in the illustrated embodiment. Spring 26 may be provided to bias guide 22 downwardly, to hold
5 endless loop 18 out of engagement with lock 14 until sufficient tension is exerted on endless loop 18. The actuation of the lock may for example be detected by a solenoid detector that provides an indication that guide 22 has moved so that lock 14 has been engaged. It will be seen that the lock may also be actuated if an attempt is made to move the security bar 12 faster or slower than the speed at which the security bar 12 is driven by drive wheel 20.

10

The engagement of endless loop 18 by lock 14 may prevent movement of endless loop 18, as in the illustrated embodiment showing splines on a fixed gear that engage a chain. In an alternative locking arrangement (not illustrated) the guide may be in the form of a rotatable sprocket that engages the endless loop, wherein the axle
15 of the rotatable sprocket is slidable in a biased housing so that the rotatable sprocket is displaced into engagement with a fixed tooth when the locking tension is applied to the endless loop, so that the rotatable sprocket is immobilized by engagement with the fixed tooth to lock the endless loop against movement.

20

In further alternative embodiments, the guide may cooperate with the lock so that the lock is actuated when the guide is displaced by a locking tension on the endless loop. For example, movement of guide 22 may be detected electronically and a pin or lever may be actuated, for example by a solenoid, when movement of the guide is detected, so that the pin or lever locks the endless loop against movement. A
25 guide may also be mechanically linked to a locking pin or lever, so that movement of the guide forces the locking pin or lever into position to lock the endless loop.

30

In alternative embodiments, the engagement of the endless loop by the lock may serve merely to inhibit the movement of the endless loop, providing a braking effect. As would be the case, for example, if endless loop 18 were a belt and lock 14 was adapted to frictionally engage the belt. It will be appreciated that many different

types of endless loop **18** may be used to implement alternative aspects of the invention, including various kinds of chains and belts, and lock **14** may take the form of a wide variety of members adapted to engage endless loop **18**.

5 It will be appreciated that in some embodiments, if an obstacle is placed in the path of security bar **12** as it is being moved downwardly by drive wheel **20**, the resultant tension on endless loop **18** may be effective to displace guide **22** so that lock **14** is engaged. In which case, the locking mechanism of the invention may function as a safety catch to prevent security bars **12** from crushing an object trapped in the
10 opening.

 Although various embodiments of the invention are disclosed herein, many adaptations and modifications may be made within the scope of the invention in accordance with the common general knowledge of those skilled in this art. For
15 example Figures **6** and **7** schematically illustrate alternative arrangements of guide **22**, lock **14**, endless loop **18**, drive wheel **20** and security bar **12**, which may be utilized for alternative installations of the invention. It is also to be understood that the description of drive wheel **20** as being driven or not driven is a functional term that
20 merely indicates that there are two states in which drive wheel **20** may provide different effects on endless loop **18**. In the driven state, drive wheel **20** is effective to move a device connected to endless loop **18** in a desired direction. Whereas in the state in which it is not driven, drive wheel **20** will resist rotation to the extent that it will effectively counteract a force applied to the device connected to the endless loop, so that the lock is engaged. In alternative embodiments, the resistance to movement
25 may be provided by a clamp **19** or sprocket **21** that engages endless loop **18**. When applied, clamp **19** may frictionally engage the endless loop **18**.

 Contemplated modifications of the invention include the substitution of known equivalents for any aspect of the invention in order to achieve the same result in
30 substantially the same way. In the following claims, the word "comprising" is used as

an open-ended term, substantially equivalent to the phrase "including, but not limited to".

What is claimed is:

1. An endless loop lock comprising:
 - (a) a drive wheel adapted to be driven at a drive speed, wherein the drive wheel has a resistance to rotation at a speed different from the drive speed;
 - 5 (b) an endless loop engaging the drive wheel at a first portion on the endless loop, wherein the endless loop is adapted to be driven by the drive wheel to move a device connected to the endless loop;
 - (c) a guide biased against a second portion of the endless loop at a position spaced apart from the drive wheel;
 - 10 (d) a lock for engaging the endless loop to inhibit movement of the endless loop, the guide being positioned to bias the endless loop out of engagement with the lock when the endless loop is driven by the drive wheel;
 - (e) wherein the lock may be actuated by a force on the device connected to the endless loop, when the force urges the endless loop and the device connected to the endless loop to move against the resistance to rotation provided by the drive wheel so as to exert a tension on the second portion of the endless loop, and the tension on the second portion of the endless loop is sufficient to displace the guide so that the endless loop engages the lock.
- 20 2. The endless loop lock of claim 1, wherein the device connected to the endless loop is a security bar.
3. The endless loop lock of claim 1, wherein the endless loop is a chain.
- 25 4. The endless loop lock of claim 2, wherein the endless loop is a chain.
5. The endless loop lock of claim 1, wherein the drive wheel is powered by an electric motor.
- 30 6. The endless loop lock of claim 2, wherein the drive wheel is powered by an electric motor.

7. The endless loop lock of claim 3, wherein the drive wheel is powered by an electric motor.

5 8. The endless loop lock of claim 1 further comprising a clamp for clamping the endless loop, wherein the actuation of the clamp provides the resistance to rotation of the drive wheel.

10 9. The endless loop lock of claim 7 further comprising a clamp for clamping the endless loop, wherein the actuation of the clamp provides the resistance to rotation of the drive wheel.

10. The endless loop lock of claim 1 further comprising a detector for detecting the displacement of the guide.

15 11. An endless loop lock comprising:

(a) a means for exerting tension on an endless loop, wherein the means for exerting tension cooperates with the endless loop so that tension may be applied to the endless loop against a resistance provided by the means for exerting tension;

20 (b) a guide biased against the endless loop at a position spaced apart from the means for exerting tension on the endless loop;

(c) a lock for engaging the endless loop to inhibit movement of the endless loop, the guide being positioned to bias the endless loop out of engagement with the lock when the endless loop is not under a locking tension;

25 (d) wherein the lock may be actuated by the application of a force on the endless loop, the lock being actuated when the force urges the endless loop to move against the resistance provided by the means for exerting tension on the endless loop so that the locking tension is applied to the endless loop across the guide, wherein the locking tension is sufficient to displace the guide so that the endless loop
30 engages the lock.

12. The endless loop lock of claim 11, wherein a security bar is connected to the endless loop.

13. The endless loop lock of claim 11, wherein the endless loop is a chain.

5

14. The endless loop lock of claim 12, wherein the endless loop is a chain.

15. The endless loop lock of claim 11 wherein the means for exerting tension on the endless loop is a clamp for clamping the endless loop.

10

16. The endless loop lock of claim 11 further comprising a detector for detecting the displacement of the guide.

17. An endless loop lock comprising:

15

(a) a tensioning mechanism for exerting tension on an endless loop, wherein the tensioning mechanism cooperates with the endless loop so that tension may be applied to the endless loop against a resistance provided by the tensioning mechanism;

20

(b) a guide biased against the endless loop at a position spaced apart from the tensioning mechanism;

(c) a lock for engaging the endless loop to inhibit movement of the endless loop, the guide being positioned to bias the endless loop out of engagement with the lock when the endless loop is not under a locking tension;

25

(d) wherein the lock may be actuated by the application of a force on the endless loop, the lock being actuated when the force urges the endless loop to move against the resistance provided by the tensioning mechanism so that the locking tension is applied to the endless loop across the guide, wherein the locking tension is sufficient to displace the guide so that the endless loop engages the lock.

18. An endless loop lock comprising:

5 (a) a tensioning mechanism for exerting tension on an endless loop, wherein the tensioning mechanism cooperates with the endless loop so that tension may be applied to the endless loop against a resistance provided by the tensioning mechanism;

(b) a guide biased against the endless loop at a position spaced apart from the tensioning mechanism;

10 (c) a lock for engaging the endless loop to inhibit movement of the endless loop, the guide cooperating with the lock so that the lock is actuated when the guide is displaced by a locking tension on the endless loop;

15 (d) wherein the lock may be actuated by the application of a force on the endless loop, the lock being actuated when the force urges the endless loop to move against the resistance provided by the tensioning mechanism so that the locking tension is applied to the endless loop across the guide, wherein the locking tension is sufficient to displace the guide so that the endless loop engages the lock.

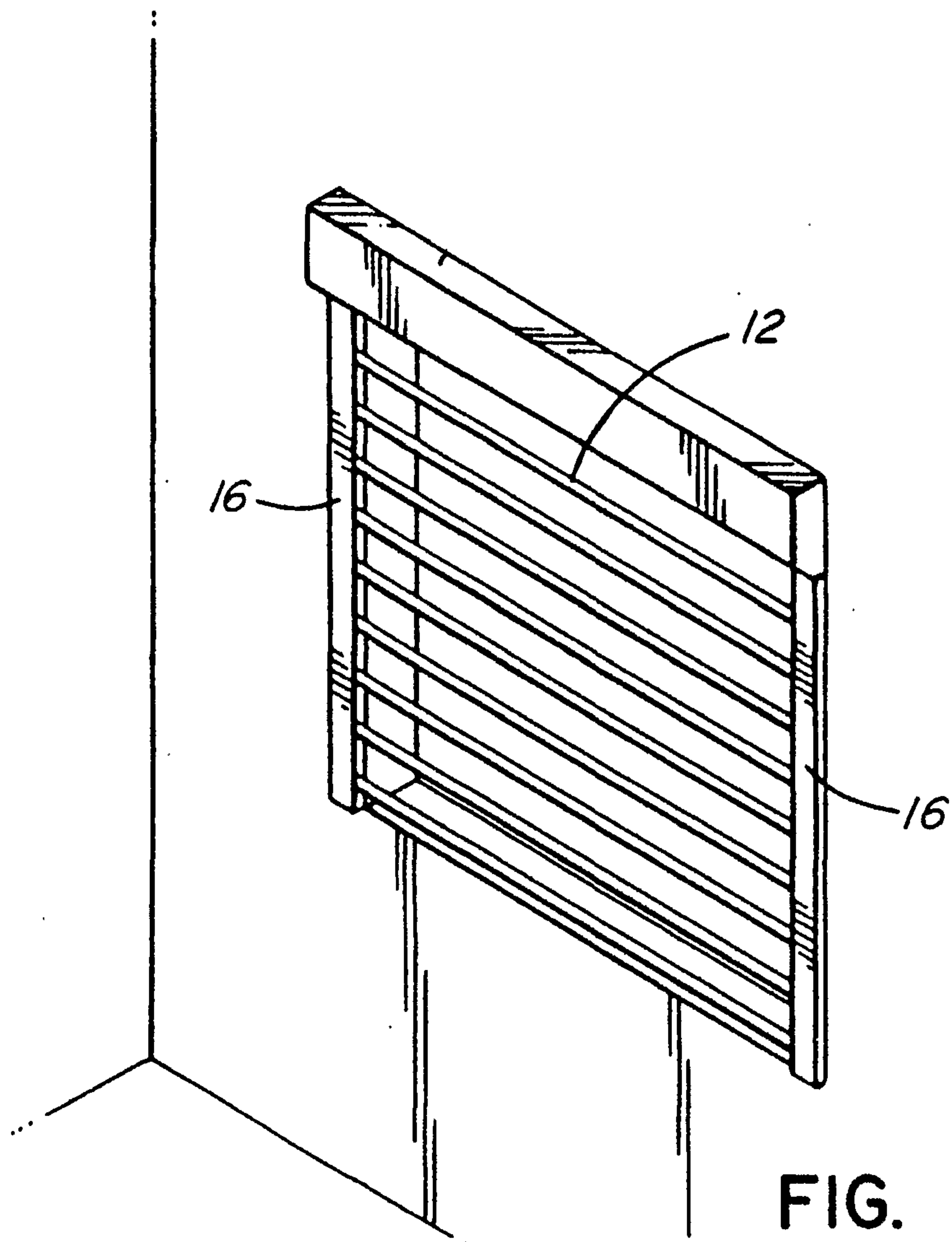

FIG. 1

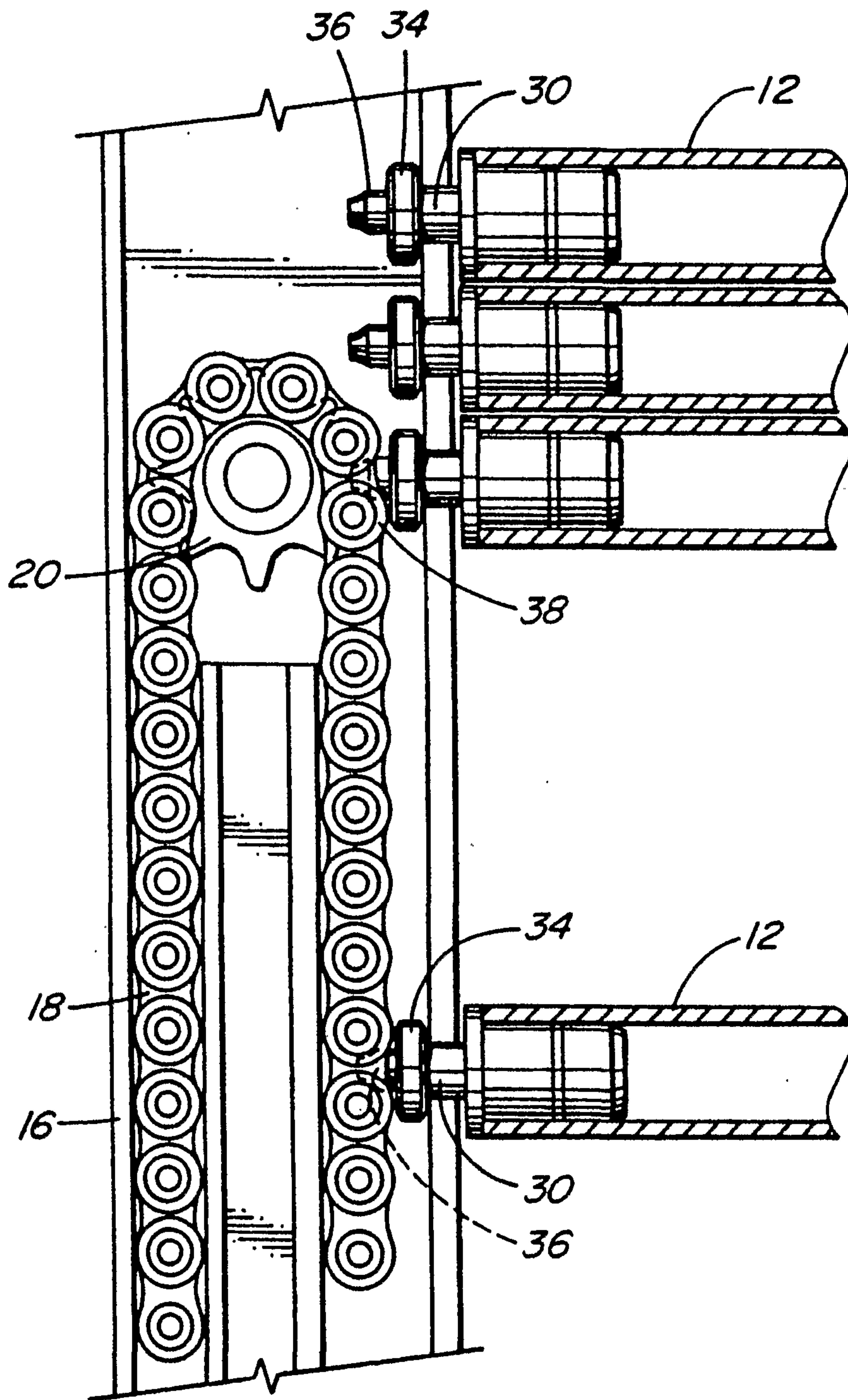

FIG. 2

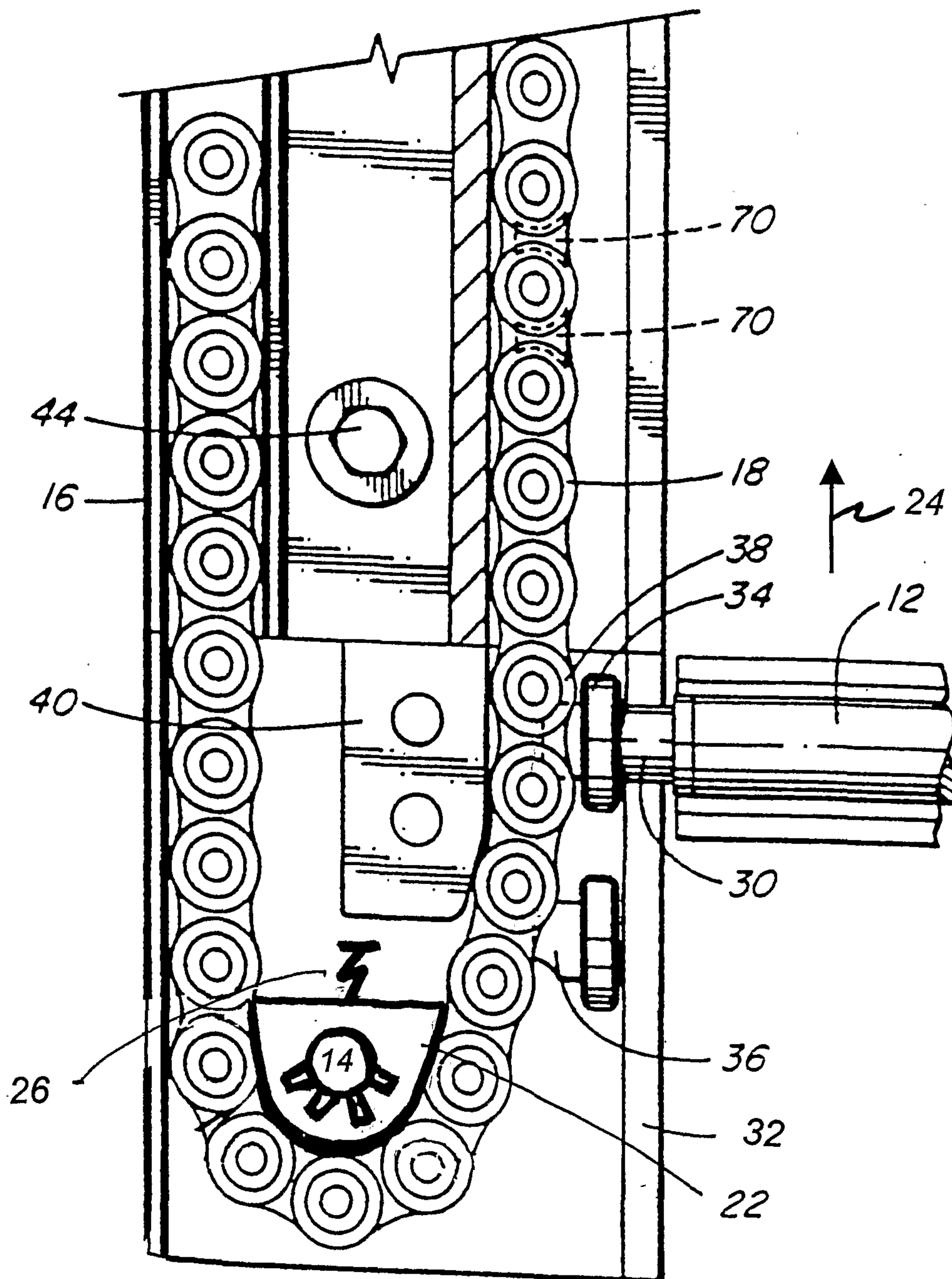

FIG. 3

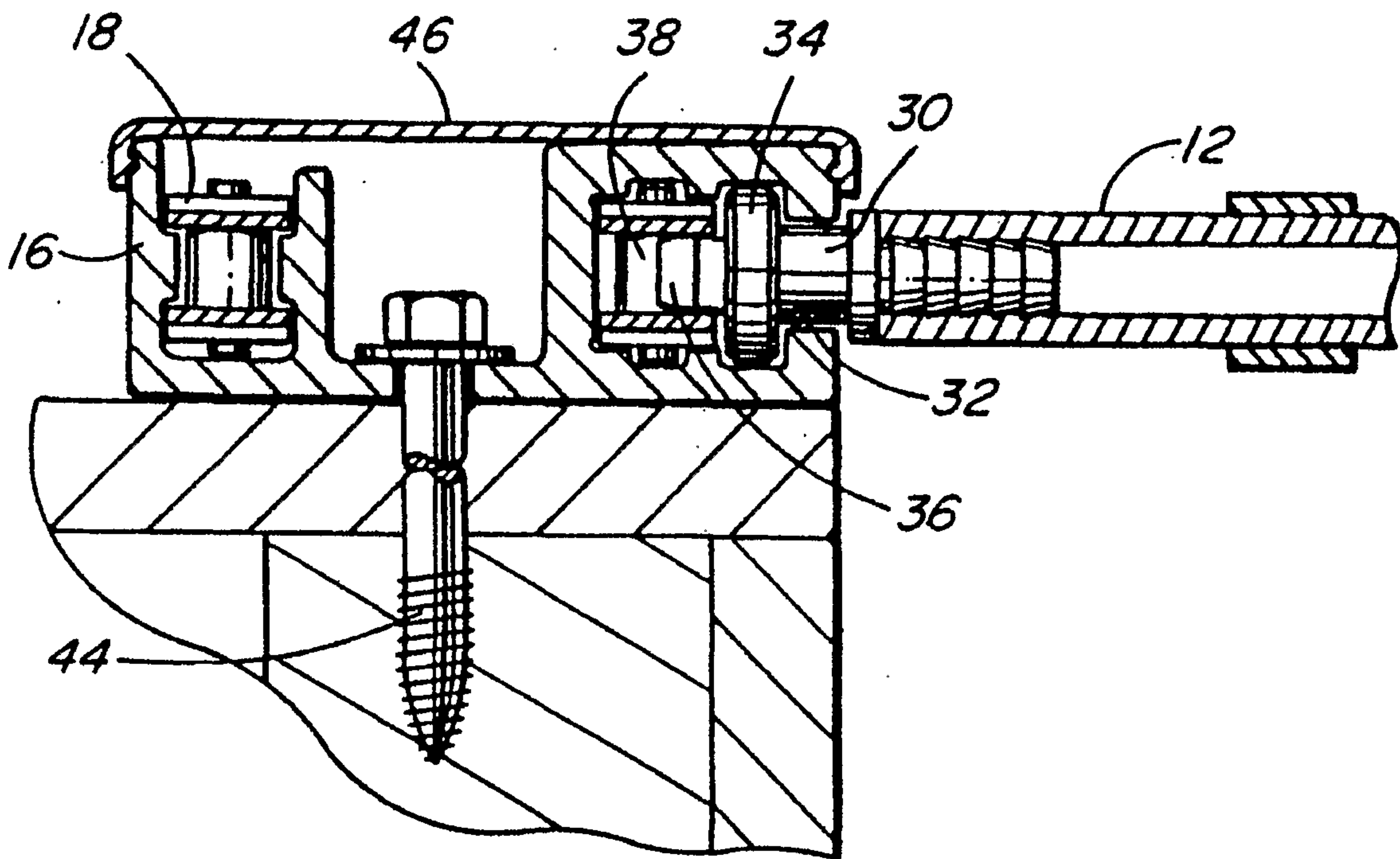

FIG. 4

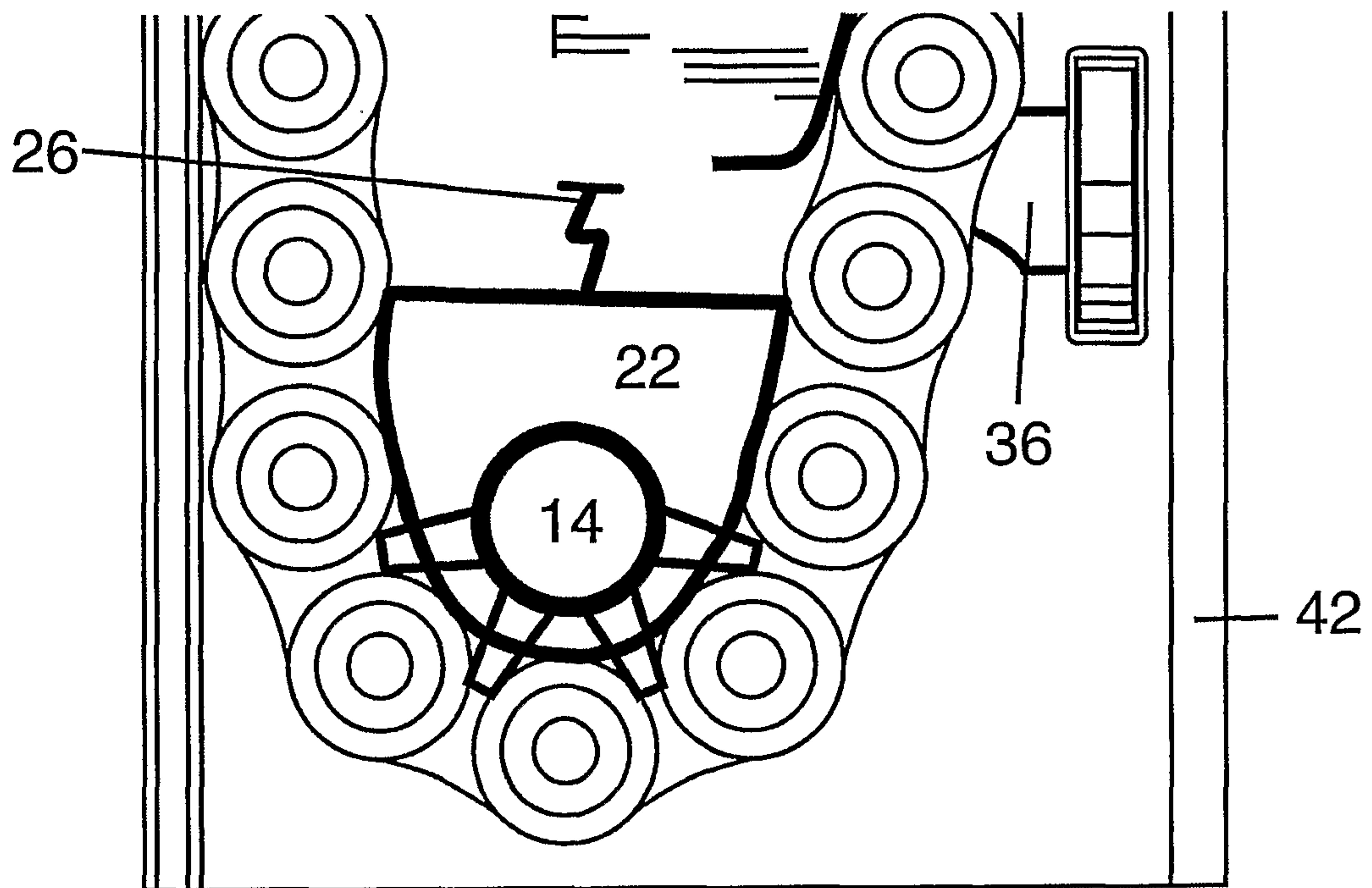

Figure 5

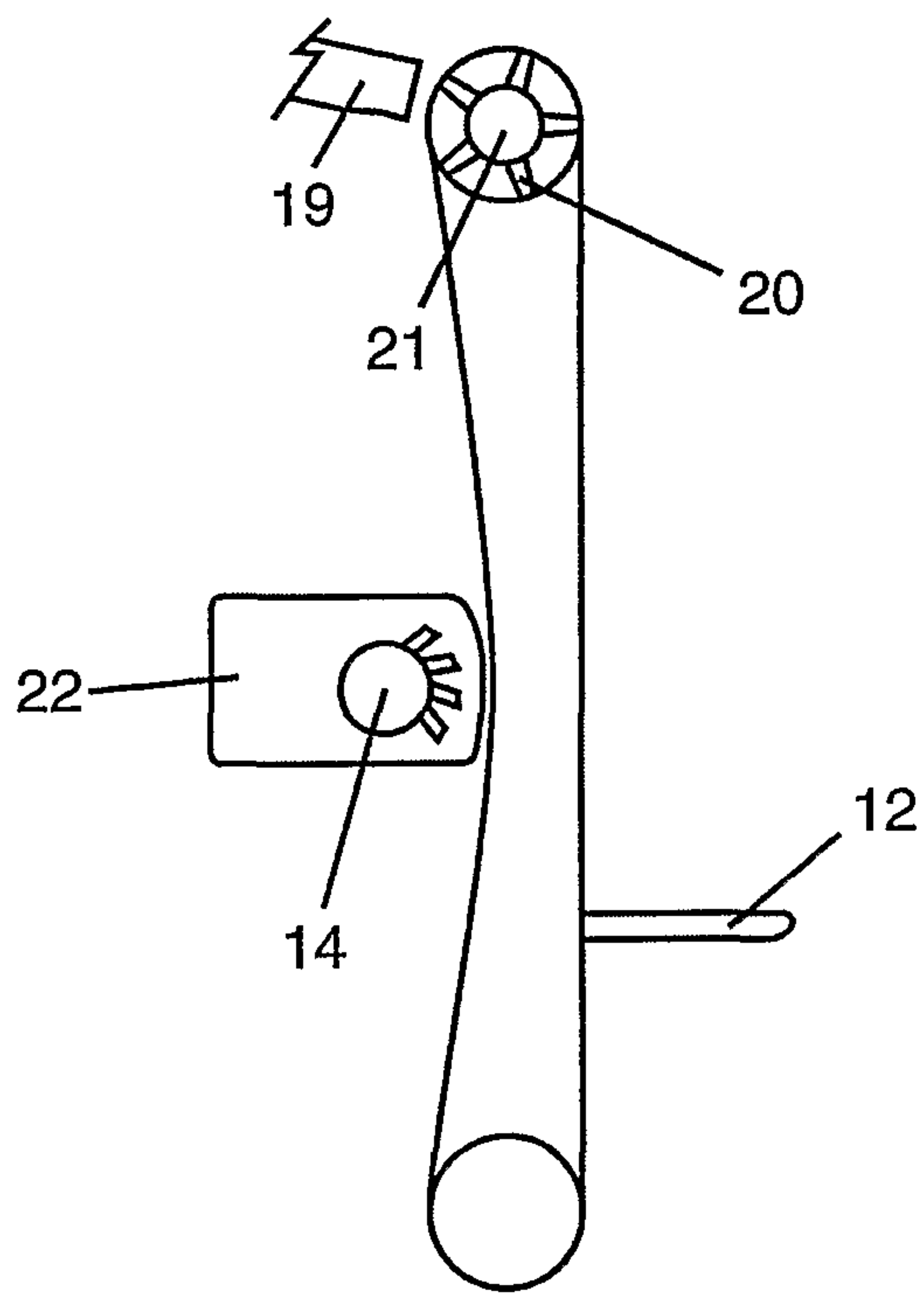

Figure 6

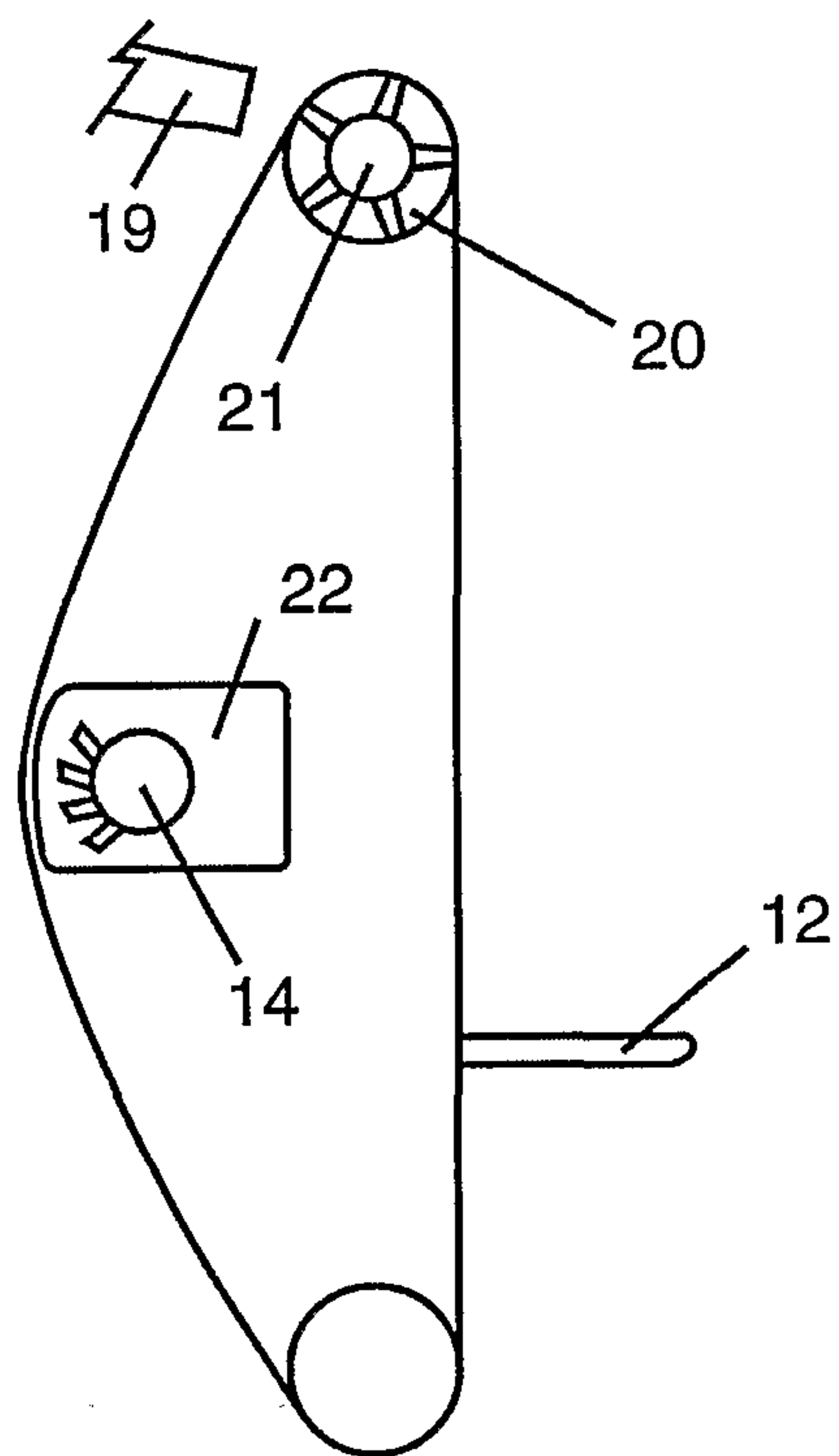

Figure 7

