

(19) **DANMARK**

(10) **DK/EP 3411314 T3**



(12) **Oversættelse af
europæisk patentskrift**

Patent- og
Varemærkestyrelsen

-
- (51) Int.Cl.: **B 65 G 15/58 (2006.01)** **B 65 G 17/46 (2006.01)**
- (45) Oversættelsen bekendtgjort den: **2022-09-05**
- (80) Dato for Den Europæiske Patentmyndigheds bekendtgørelse om meddelelse af patentet: **2022-07-27**
- (86) Europæisk ansøgning nr.: **17748049.8**
- (86) Europæisk indleveringsdag: **2017-02-01**
- (87) Den europæiske ansøgnings publiceringsdag: **2018-12-12**
- (86) International ansøgning nr.: **US2017015970**
- (87) Internationalt publikationsnr.: **WO2017136402**
- (30) Prioritet: **2016-02-01 US 201662289421 P**
- (84) Designerede stater: **AL AT BE BG CH CY CZ DE DK EE ES FI FR GB GR HR HU IE IS IT LI LT LU LV MC MK MT NL NO PL PT RO RS SE SI SK SM TR**
- (73) Patenthaver: **Laitram, LLC, Legal Department , 200 Laitram Lane, Harahan, LA 70123, USA**
- (72) Opfinder: **BOGLE, David W., 1354 Becca Teal Place, Round Rock, Texas 78681, USA**
KEB, Richard A., 616 Fay Avenue, Metairie, Louisiana 70003, USA
BANNERMAN, Adam E., 112 Forest Drive, Mandeville, Louisiana 70471, USA
ZAMBRANO, Krissie K., 4530 Utopia Drive, Metairie, LA 70001, USA
- (74) Fuldmægtig i Danmark: **CHAS. HUDE A/S, Langebrogade 1, 2. B2, 1411 København K, Danmark**
- (54) Benævnelse: **Modul for et magnetisk transportbånd**
- (56) Fremdragne publikationer:
WO-A1-2015/048642
WO-A2-2012/165769
CN-Y- 2 529 844
JP-A- 2012 041 145
JP-U- S55 155 713
US-A- 4 197 934
US-A1- 2009 308 716
US-A1- 2014 346 014

DESCRIPTION

BACKGROUND OF THE INVENTION

[0001] The invention relates generally to power-driven conveyors and more particularly to modular plastic conveyor belts with metal-attracting or ferro-magnetic properties.

[0002] Conveyors are often used to transport items. To convey metal or magnetically attractable items, such as bakery pans, conveyors have been used that include magnetic elements to retain the magnetically-attractive items on the conveyor. Integrating the magnetic elements into the conveyor may be cumbersome.

[0003] Modular plastic conveyor belts are widely used in various industries to convey products. Modular plastic conveyor belts are constructed of a series of rows of side-by-side belt modules. Hinge eyes along opposite ends of each row interleave with hinge eyes of consecutive rows. A hinge rod inserted in the interleaved hinge eyes connects the rows together at hinge joints into an endless conveyor belt loop. JP 2012 041145 A discloses a conveyor belt according to the preamble of claim 1.

SUMMARY OF THE INVENTION

[0004] A magnetic conveyor belt module comprises a main body, a magnetic element and a carrier for a magnetic element coupled to the main body. The module allows a magnetic element to be easily and removably integrated with the module. A magnetic element is seated in a recess near the top surface of the module body. A cover covers the magnetic element. A retention element retains the cover and magnetic element in place.

[0005] The conveyor belt of the present invention is defined by at least the technical features of claim 1. Further features of the present invention are listed in the dependent claims.

BRIEF DESCRIPTION OF THE DRAWINGS

[0006] These features and aspects of the invention, as well as its advantages, are better understood by referring to the following description, appended claims, and accompanying drawings, in which:

FIG. 1 is an exploded view of a magnetic conveyor belt module according to an illustrative embodiment of the invention;

FIG. 2 is a top view of the magnetic conveyor belt module of FIG. 1 when assembled;

FIG. 3 is a cross-sectional view of the magnetic conveyor belt module through lines A-A of FIG. 2;

FIG. 4 is a cross-sectional view of the magnetic conveyor belt module through lines B-B of FIG. 2;

FIG. 5 is a cross-sectional view of the magnetic conveyor belt module through lines C-C of FIG. 2;

FIG. 6 is a bottom view of the magnet-carrying insert of the magnetic conveyor belt module;

FIG. 7 is an exploded view of another embodiment of a magnetic conveyor belt module;

FIG. 8 is a top view of the magnetic conveyor belt module of FIG. 7;

FIG. 9 is a cross-sectional view of the magnetic conveyor belt module of FIG. 8 through lines A-A;

FIG. 10 is a cross-sectional view of the magnetic conveyor belt module of FIG. 8 through lines B-B;

FIG. 11 is an isometric view of a magnetic conveyor belt module during formation according to another embodiment of the invention;

FIG. 12 is a top view of the magnetic conveyor belt module of FIG. 11 after overmolding of a cover for the magnetic element;

FIG. 13 is a cross-sectional view through lines A-A in FIG. 12;

FIG. 14 is an exploded, isometric view of a magnetic conveyor module according to another embodiment of the invention;

FIG. 15 is a top view of the module of FIG. 14;

FIG. 16 is a cross-sectional view of the magnetic conveyor belt module of FIG. 14 through lines A-A;

FIG. 17 is a cross-sectional view of the magnetic conveyor belt module of FIG. 14 through lines B-B;

FIG. 18 is a bottom view of the cover of the magnetic conveyor belt module of FIG. 14;

FIG. 19 is an exploded view of a magnetic conveyor belt module according to another embodiment of the invention;

FIG. 20 is a top view of the assembled magnetic conveyor belt module of FIG. 19;

FIG. 21 is an edge view of the assembled magnetic conveyor belt module of FIG. 19;

FIG. 22 is a side view of the assembled magnetic conveyor belt of FIG. 19;

FIG. 23 is a top view of the magnet-carrying insert of the magnetic conveyor belt module of FIG. 19;

FIG. 24 is an end view of the magnet-carrying insert of the magnetic conveyor belt module of FIG. 19;

FIG. 25 is a side view of the magnet-carrying insert of the magnetic conveyor belt module of FIG. 19; and

FIG. 26 is a bottom view of the magnet-carrying insert of the magnetic conveyor belt module of FIG. 19.

FIG. 27 is an isometric view of a portion of a conveyor belt formed by alternating magnetic conveyor belt modules and non-magnetic conveyor belt module to form the conveyor belt;

FIG. 28 is a top view of the conveyor belt portion of FIG. 27;

FIG. 29 is a side view of the conveyor belt portion of FIG. 27;

FIG. 30 is an isometric view of a portion of a conveyor belt formed by alternating magnetic conveyor belt modules and non-magnetic conveyor belt module to form the conveyor belt according to another embodiment of the invention;

FIG. 31 is a top view of the conveyor belt portion of FIG. 30; and

FIG. 32 is a side view of the conveyor belt portion of FIG. 31.

DETAILED DESCRIPTION OF THE INVENTION

[0007] A conveyor belt module integrates a magnetic element to attract conveyed articles against the conveying surface of the module. The invention will be described below relative to certain illustrative embodiments, though those skilled in the art will recognize that the invention is not limited to the described embodiments.

[0008] Referring to FIGS. 1-6, a conveyor belt module 10 for a conveyor belt includes a module body 12 that extends longitudinally from a first end 14 to a second end 15. The longitudinal direction is the direction of belt travel when such a module is built into a modular conveyor belt. The module body extends laterally from a first edge 16 to a second edge 17. In thickness, the module body extends from an upper surface 18, which forms the conveying surface on which conveyed articles are carried, to an opposite surface 19. Hinge structure, shown as eyes 20, extends longitudinally outward from the first and second ends of the module body. The tops of the hinge eyes form a continuation of the conveying surface. The hinge eyes on one end of the module body are laterally offset from the hinge eyes at the other end. Gaps 26 between laterally consecutive hinge eyes are sized to receive the hinge eyes of similar

modules in an adjacent row of modules in a conveyor belt.

[0009] The modules are preferably made of thermoplastic polymers, such as polypropylene, polyethylene, acetal, or composite polymers in an injection-molding process. Plastic conveyor belt modules made in this way are available commercially from Intralox, L.L.C., of Harahan, La., USA. In another embodiment, the modules are formed of stainless steel or another suitable material.

[0010] A number of modules 10 are used to form a conveyor belt. The belt may comprise a series of rows of edge-to-edge belt modules. Modules of different lateral widths are used to construct the belt in a bricklay pattern. But wide modules extending the entire width of the belt could alternatively be used. The belt may comprise a combination of magnetic and non-magnetic modules. The rows are interconnected by hinge rods 22 extending laterally through the passageways formed by the aligned openings in the interleaved hinge eyes between adjacent rows. The belt conveys articles atop the conveying surfaces 18 of the modules along an upper carryway portion of the conveyor. The belt is trained around sprockets mounted on each end of the carryway, and returns along a returnway below the carryway.

[0011] The magnetic module 10 includes a recess, illustrated as a slot 50, in the upper surface 10 for receiving a magnetic insert. The illustrative slot 50 extends from the first edge 16 to an intermediate location within the body, and is open to the side of the module. The illustrative slot 50 slidably receives a magnetic insert 70 housing a magnet 80. In another embodiment, the recess has another shape other than a slot.

[0012] The slot has chamfered sides 51, 52 that angle inwards and a rounded end 53. The insert 70 has a rounded tip 73 complementary to the rounded end 53 and chamfered or tapering sides 71, 72 to form a substantially trapezoidal cross-section. The insert 70 includes a recess 74 or pocket for receiving a magnetic element, illustrated as a rectangular magnetic bar 80, though the invention is not so limited. When assembled, the upper surface of the insert 70 is flush with the upper surface of the module body 12 to form a substantially continuous surface. The insert 70 covers and encapsulates the magnetic bar 80.

[0013] The module further includes a retention element for retaining the magnetic insert 70 within the module body. According to an illustrative embodiment of the invention, the insert interacts with a hinge rod retaining element 90 to retain the insert within the module body.

[0014] The illustrative rod retaining element 90 comprises a movable shuttle plug, such as the shuttle plugs describe in US Patent Number 5,904,241 and US Patent Number 6,814,223, which are incorporated herein by references, or the retaining elements US Patent Number 6,857,516 and US Patent Number 7,255,227, the contents of which are incorporated herein by reference.

[0015] The illustrative shuttle plug 90 is inserted in a passageway 91 in the module body and into an edge hinge element 20a for retaining a rod 22 within a hinge passageway. The shuttle

plug includes a detent 93 that extends through an opening, shown as a channel 59, in the floor of the module body slot 50. The detent engages a recess, shown as a channel 78, in the insert 70 to retain the insert within the module body. The opening 59 and recess 78 allow the shuttle plug 90 to slide within the passageway 91 while still engaging the recess of the insert 70.

[0016] The magnetic bar 80 is preferably centered on the module body, as shown in FIG. 5.

[0017] The use of a slot, insert and automatic locking mechanism facilitates integration of an article-attracting element, such as a magnet, into the conveyor belt module.

[0018] In another embodiment, shown in FIG. 7-10, a magnetic element is sandwiched between elements in the module. The module 110 comprises a base member 120, a top cover 150 and a magnet 180 or magnetic element sandwiched between the top cover and base member. The base member has a recess 122 for receiving the top cover 150. When received in the recess 122, the top cover upper surface is flush with the upper surface of the base member 120, as shown in FIG. 9, and encapsulates the magnet 180. The module includes openings 126 within the hinge elements 124 for receiving hinge elements 154 on the top cover 150. The base hinge elements 124 sandwich the top cover hinge elements 154. One or more hinge rods 160 form a retention element for retaining the top cover on the base member. The base member and/or the top cover may include a pocket 171 for accommodating the magnet 180. The pocket 171 is sized and shaped to seat the magnet 180. The illustrative module further includes a shuttle plug 190 for retaining the hinge rods within the hinge rod passageway.

[0019] FIGS. 11-13 show another embodiment of a magnetic conveyor belt module 210. The conveyor belt module 210 integrates a magnetic element 280 into the module during a secondary molding process. A base member 220, formed during an initial mold includes a recess or pocket 271 for receiving a magnetic element 280. The recess or pocket 271 includes guide pads 272, 273 for positioning the magnetic element 280. After positioning the magnetic element 280 in the recess or pocket 271, a cover 250 is overmolded onto the module to encapsulate the magnetic element 280. The base member 220 includes two passageways 221, 222 extending down from the recess 271 for creating solid protrusions 255, 256 anchoring the overmolded cover 250 to the base member 220. The overmolded cover 250 preferably has a top surface that is flush with the top surface of the base member 220, as shown in FIG. 13.

[0020] In one embodiment, the magnetic element 280 comprises a samarium cobalt magnet, allowing the magnet the ability to maintain the ability to attract after undergoing the high temp overmolding process.

[0021] In another embodiment of the invention, shown in FIGS. 14-18, a cover 350 for covering a magnetic element 380 may be ultrasonically welded to a base member 320 to form a magnetic conveyor belt module 300. The magnetic element 380 is positioned within a recess or pocket 371 in the upper surface of the base member 320. The recess or pocket 371

includes a deeper recess 372 configured to receive and position the magnetic element 380. The cover 350, as shown in FIG. 18, includes weld joints 352 for ultrasonically welding the cover to the base member 322 to encapsulate the magnetic element 380 within the body of the module. The cover also includes a recess 353 for receiving the top portion of the magnetic element 380. When assembled, the magnetic conveyor belt module integrates the magnetic element 380 into the body while providing a substantially continuous upper conveying surface 311.

[0022] FIGS. 19-26 show a magnetic conveyor belt module 400 according to another embodiment of the invention. The magnetic conveyor belt module includes a module body 412 having hinge elements 420 and a recess, shown as a slot 450, for receiving a magnetic insert 470 housing a magnet 480. The magnetic conveyor belt module 400 is similar to the embodiment shown in FIGS. 1-6, with the addition of an insert retainer that engages the rod retaining element 490 when the module is fully assembled. The illustrative insert retainer comprises first and second protrusions 475, 476 on the bottom surface of the insert 470 for engaging recesses 462, 464 in the module body.

[0023] The illustrative magnetic insert 470 includes a rounded tip that fits into a rounded end 453 of the slot 450.

[0024] The module includes a shuttle plug 490 inserted in a passageway 491 in the module body and into an edge hinge element for retaining a rod 494 within a hinge passageway. The shuttle plug includes a detent 493 that extends through an opening or abuts a side edge 459 in the floor of the module body slot 50. The detent engages a recess, shown as a channel 478, in the insert 470 to retain the insert within the module body. The opening 459 and channel 478 allow the shuttle plug 490 to slide within the passageway 491 while still engaging the recess of the insert 470. The channel 478 is between the first and second protrusions 475, 476 on the insert. When the front protrusion 479 is locked in the recess 462, the second protrusion fits in the rear recess 464 and locks the detent 493 of the shuttle plug within the passageway.

[0025] The illustrative first protrusion 475 on the insert includes a sloped front face 479 to facilitate insertion and locking of the insert 470.

[0026] As shown in FIG. 24, the insert 470 includes a base portion 471 and an overhanging upper portion 472. The base portion is inserted in the slot 450, with the upper portion 472 extending above the upper surface 401 of the module body 412. The base portion 471 includes sloping sides, though the invention is not so limited. The upper portion includes a flat top surface and tapering edges 473, 474.

[0027] As shown in FIGS. 27-29, the magnetic conveyor belt module 400 can be linked with other modules to form a conveyor belt, a portion 500 of which is shown. In the embodiment of FIGS. 27, 28 and 29, a magnetic conveyor belt module 400, comprising a module body 412 and a magnetic insert 470, alternates with non-magnetic modules 510 in the conveyor belt. In the embodiment of FIGS. 27 and 28, the magnetic insert 470 has a top surface 477 that is

above the top surface 401 of the module body 412 and hinge elements 420. The top surface 511 of the adjoining non-magnetic modules 510 is flush with the top surface 401 of the module body and hinge elements 420, and therefore below the top surface 477 of the magnetic insert 470. Items placed on the conveyor belt will contact and be carried by the magnetic insert upper surface 477. The invention is not limited to alternating magnetic and non-magnetic modules and a conveyor belt can have any suitable pattern of modules.

[0028] In another embodiment, shown in FIGS. 30-32, a conveyor belt 600 comprises magnetic conveyor belt modules 400 alternating with raised non-magnetic modules 610. In this embodiment, the raised non-magnetic modules 610 includes a raised portion 613 that forms a top surface 611 that is flush with or slightly higher than the top surface 477 of the magnetic insert 470 of a connected magnetic module 400. The top surface 611 can alternatively be lower than the top surface 477 of the magnetic insert, but higher than the top surface 401 of the module body of the associated magnetic conveyor belt module. The raised portion 613 of the non-magnetic modules 610 assists in contacting and carrying items, which may reduce wear, improve return vibrations and prevent jams in the conveyor belt 600. The raised portion 613 prevents or reduces pan jams by preventing or limiting damage to the insert 470. The raised portion 613 may reduce or prevent contamination by ensuring that the magnet is retained in the conveyor belt. In addition, magnet exposure is reduced, preserving the most expensive component of the belt, resulting in monetary savings. In the embodiment of FIGS. 30-32, the raised portion 613 does not extend completely across the non-magnetic module 610, and the forwardmost and rearmost portions have a lower upper surface 612, so the hinge elements 620 are approximately flush with the top surface 401 of the module body 412 of the magnetic module. The raised portion maximizes wear resistance with minimal impact on the magnetic strength of the conveyor belt.

[0029] The optimal height difference between the top surface 611 of the non-magnetic module and the top surface 477 of a magnetic module can vary depending on the application. The raised portion maximizes wear resistance with minimal impact on the magnetic strength

[0030] The magnetic module is not limited to the illustrative magnetic insert, and the approach of alternating magnetic modules with non-magnetic modules, where the non-magnetic module has an upper surface that is flush with or slightly higher than a cover or other insert for housing a magnet on a connected magnetic module, can have many different embodiments.

[0031] In another embodiment a cover for retaining a magnet relative to a module body can be glued or otherwise attached to the module body.

[0032] Though the illustrative embodiments show the magnet as covered, the invention is not so limited. For example, the magnetic element can be partially or fully exposed. The magnetic element may be at or near the top surface of the module, or inset from the top surface.

[0033] The invention is also not limited to the illustrative magnetic bar. The magnetic element can have any suitable size, shape, position and orientation.

[0034] In another embodiment of the invention, the module comprises magnetizable material that is added during formation of the module using injection molding. The magnetizable material can be magnetized within the mold to incorporate a magnetic element into the conveyor belt module. In one embodiment, a cover may be molded from a magnetizable plastic, and then inserted into or overmolded onto a module body. The magnetizable plastic may then be magnetized to integrate a magnetic element to a conveyor belt module.

[0035] Although the invention has been described in detail with reference to a few exemplary versions, other versions are possible. The scope of the claims is not meant to be limited to the versions described in detail.

REFERENCES CITED IN THE DESCRIPTION

Cited references

This list of references cited by the applicant is for the reader's convenience only. It does not form part of the European patent document. Even though great care has been taken in compiling the references, errors or omissions cannot be excluded and the EPO disclaims all liability in this regard.

Patent documents cited in the description

- [JP2012041145A \[0003\]](#)
- [US5904241A \[0014\]](#)
- [US6814223B \[0014\]](#)
- [US6857516B \[0014\]](#)
- [US7255227B \[0014\]](#)

PATENTKRAV

1. Transportbånd (600), omfattende:

5 et modul (400) for et magnetisk transportbånd, omfattende:

et modullegeme (412), som strækker sig i tykkelsen fra en første øvre overflade (401) til en nedre overflade, lateralt fra en første kant til en anden kant, og i længderetningen fra en første ende til en anden ende;

10 en magnetisk indsats (470), der er koblet til modullegemet (412), og

et ikke-magnetisk transportbåndmodul (610), forbundet til det magnetiske transportbåndmodul (400), **kendetegnet ved, at** den magnetiske indsats (470) omfatter en anden øvre overflade (477), som er beliggende over den første øvre overflade (401) af modullegemet (412), og ved, at det ikke-magnetiske transportbåndmodul (610) omfatter en tredje øvre overflade (611), der er ikke-magnetisk og højere end den første øvre overflade (401), og hvorved den tredje øvre overflade (611) er højere end den anden øvre overflade (477).

2. Transportbånd ifølge krav 1, ydermere omfattende en flerhed af hængselelementer (420) til hængslet forbindelse af det magnetiske transportbåndmodul (400) til det ikke-magnetiske transportbåndmodul (610).

3. Transportbånd ifølge krav 2, ydermere omfattende et stangholdeelement (490) til fastholdelse af en hængselstang (494) inden i en passage, som er dannet af hængselelementer (420).

30

4. Transportbånd ifølge krav 3, hvorved den magnetiske indsats (470) omfatter et dæksel, der modtager et magnetisk element (480), hvilket dæksel har indgreb

med stangholdeelementet (490) for at fastholde dækslet på modullegemet i det magnetiske transportbåndmodul (400).

5. Transportbånd ifølge krav 3, hvorved stangholdeelementet (490) inkluderer et
5 fremspring, og dækslet inkluderer en udsparring, som fremspringet kan gribe ind i.

6. Transportbånd ifølge krav 1, hvorved modullegemet i det magnetiske trans-
portbåndmodul (400) inkluderer en slids (450), der er dannet i den første øvre
10 overflade og strækker sig fra den første kant hen imod den anden kant, og den magnetiske indsats (470) omfatter et magnetisk element (480) samt et dæksel, der er indsat i slidsen (450), som sandwicher det magnetiske element mellem modullegemet og dækslet, hvorved dækslets overside danner den anden øvre overflade (477).

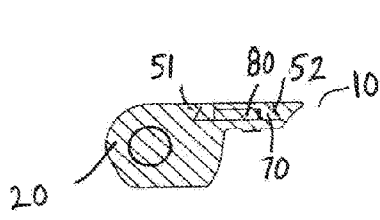

FIG. 3

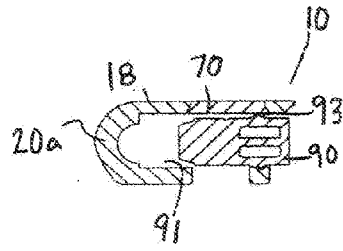
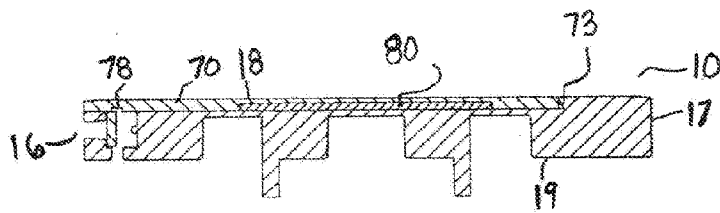

FIG. 4



SECTION C-C

FIG. 5

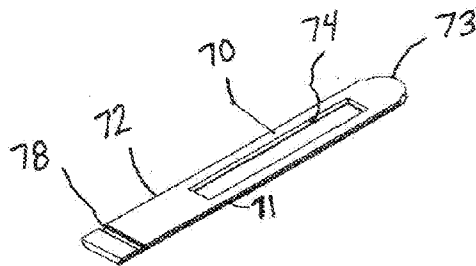

FIG. 6

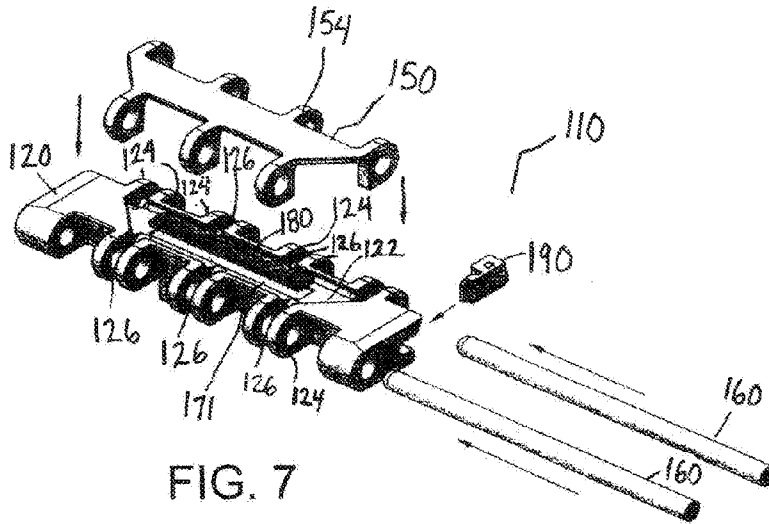

FIG. 7

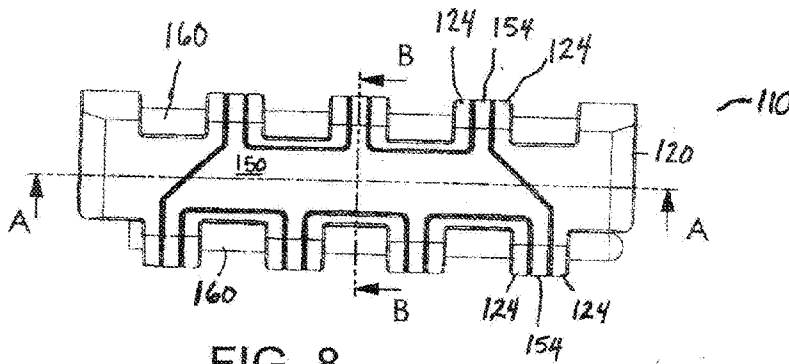

FIG. 8

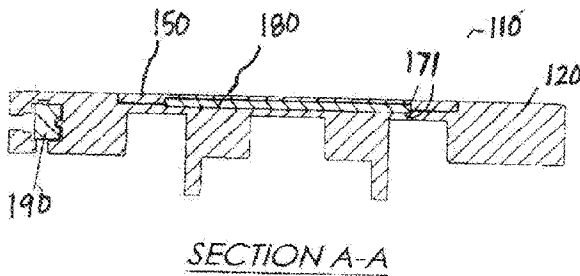
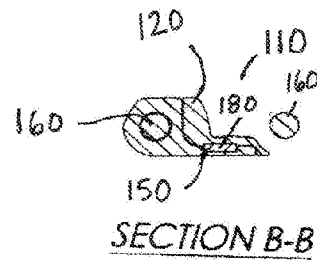
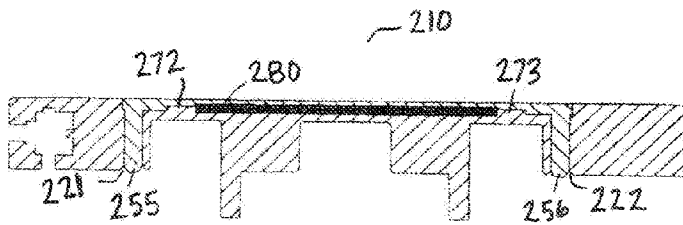
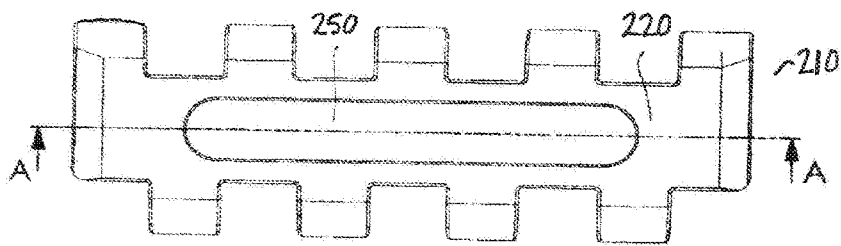
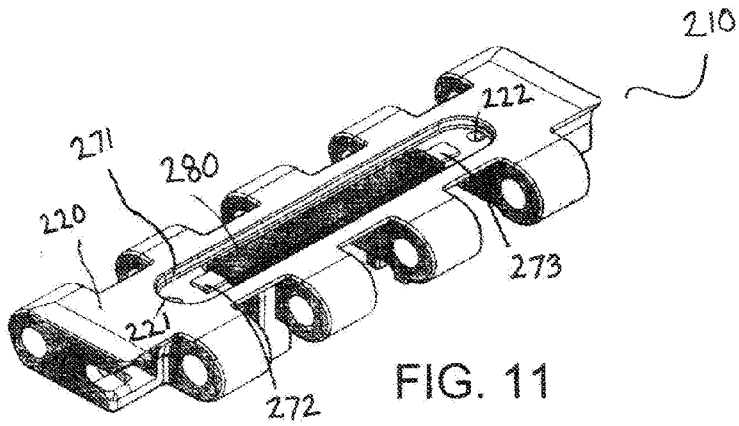

FIG. 9



SECTION B-B

FIG. 10



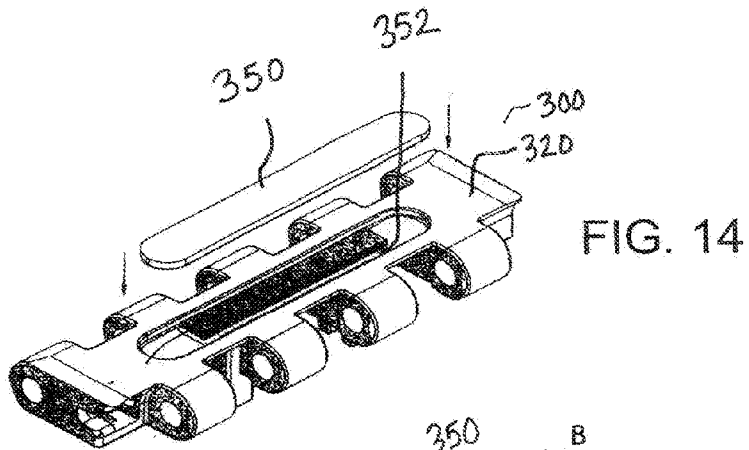

FIG. 14

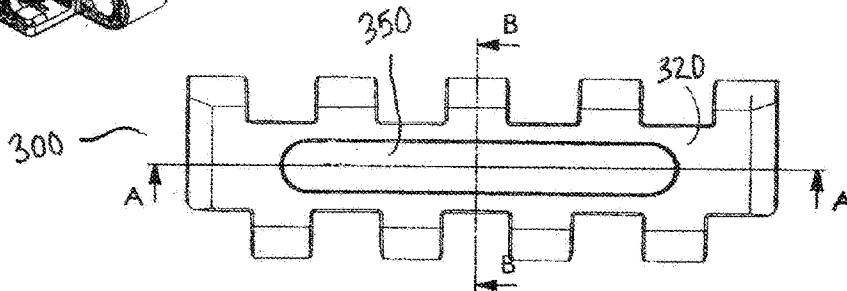

FIG. 15

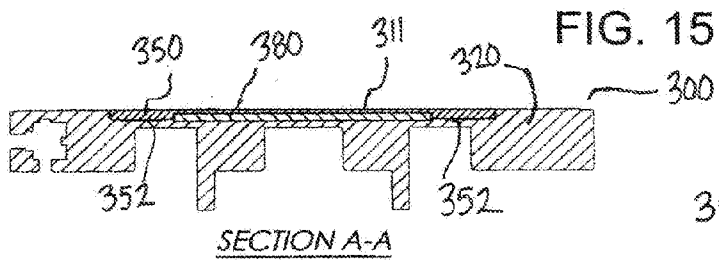
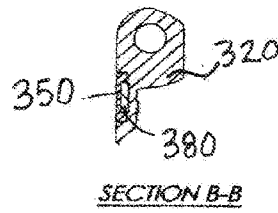

FIG. 16



SECTION B-B

FIG. 17

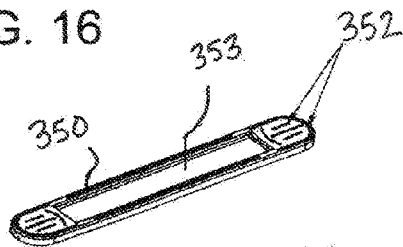

FIG. 18

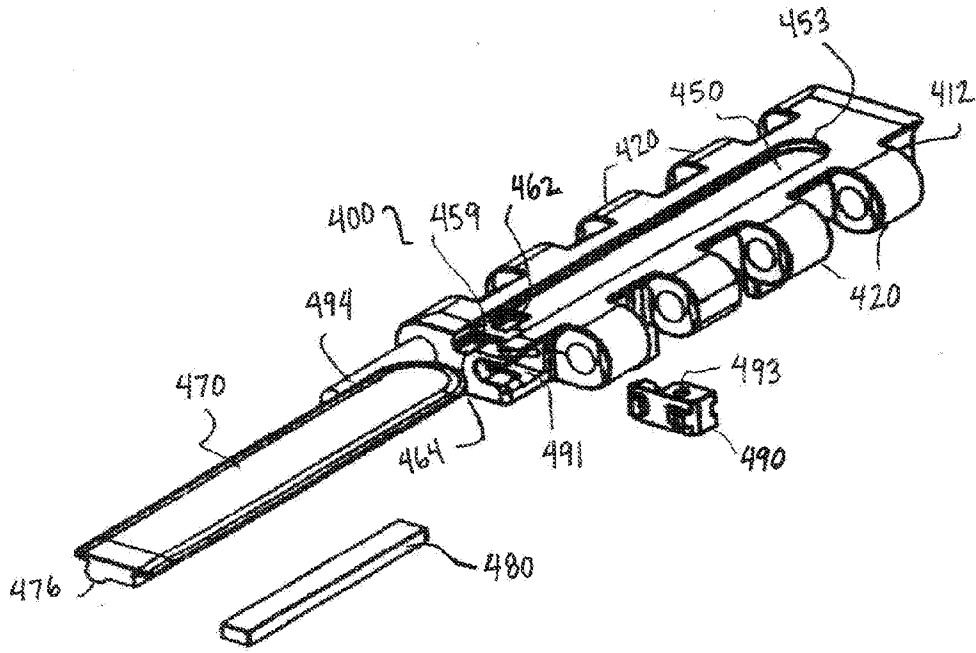

FIG. 19

FIG. 20

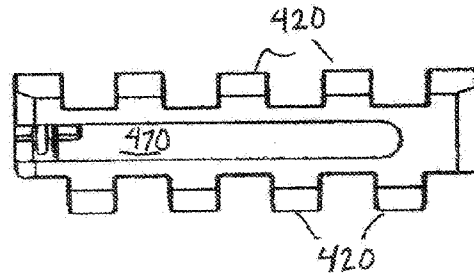

FIG. 21

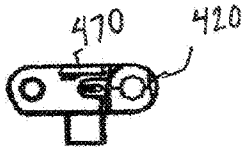

FIG. 22

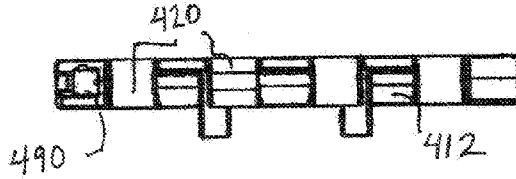

FIG. 23

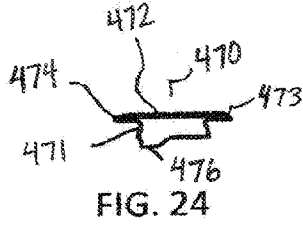
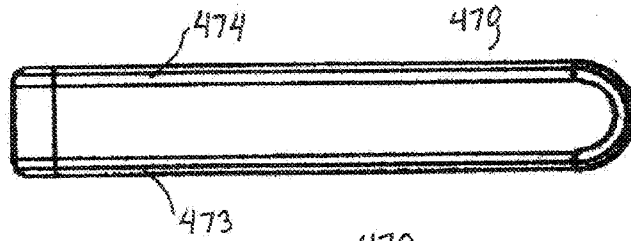

FIG. 24

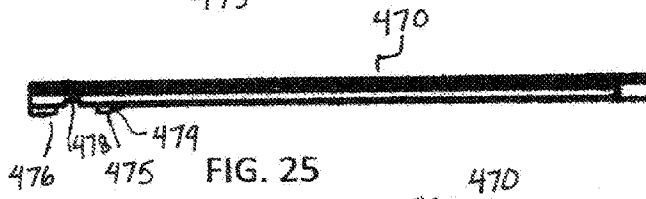

FIG. 25

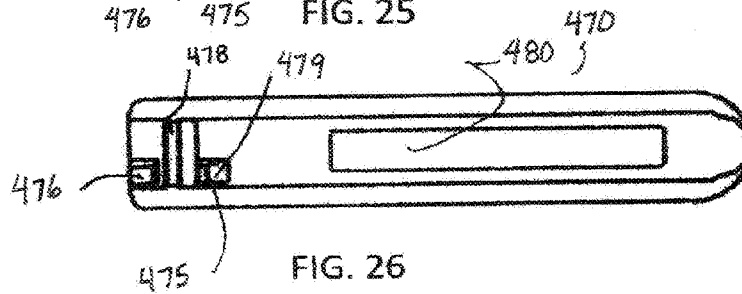

FIG. 26

